

Dual Baud Rate Generator

Programmable Divider

FEATURES

- On chip crystal oscillator or external frequency input
- Single +5v power supply
- Choice of 2 x 16 output frequencies
- 16 asynchronous/synchronous baud rates
- Direct UART/USRT/ASTRO/USYNRT compatibility
- Full duplex communication capability
- Re-programmable ROM via CLASP® technology allows generation of other frequencies
- TTL, MOS compatibility
- Compatible with COM 5016

PIN CONFIGURATION

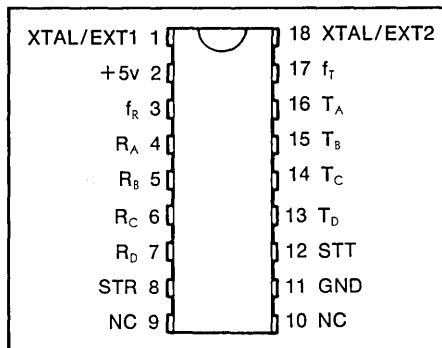

BLOCK DIAGRAM

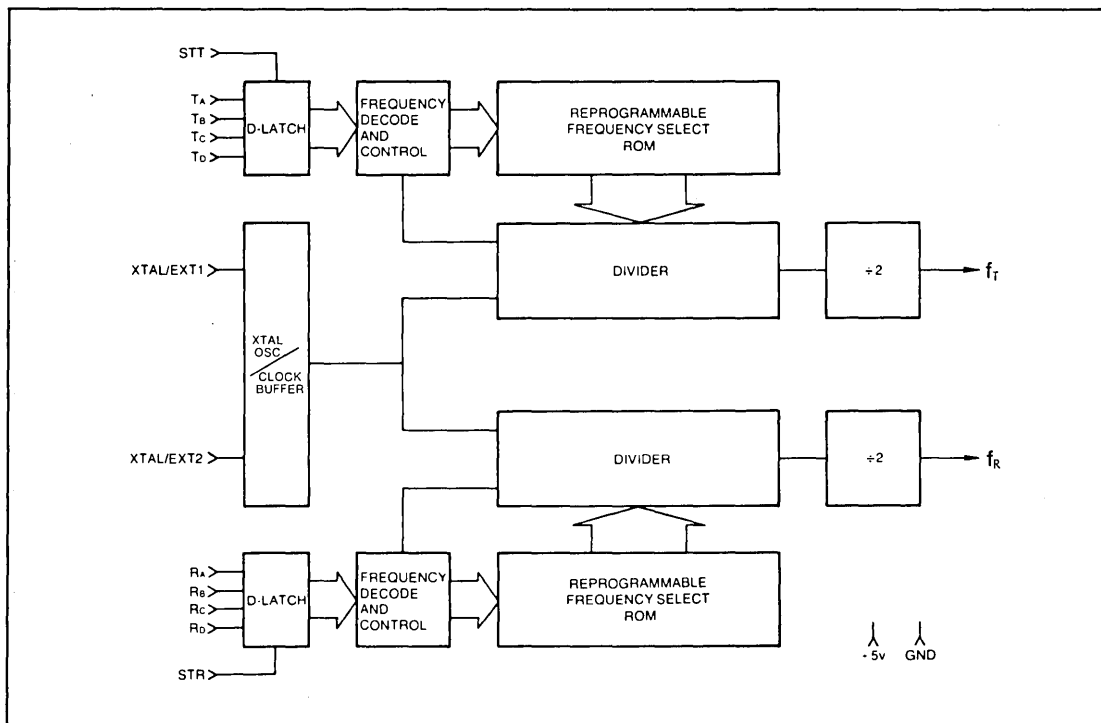

SECTION IV

General Description

The Standard Microsystem's COM 8116 is an enhanced version of the COM 5016 Dual Baud Rate Generator. It is fabricated using SMC's patented COPLAMOS® and CLASP® technologies and employs depletion mode loads, allowing operation from a single +5v supply.

The standard COM 8116 is specifically dedicated to generating the full spectrum of 16 asynchronous/synchronous data communication frequencies for 16X UART/USRT devices. A large number of the frequencies available are also useful for 1X and 32X ASTRO/USYNRT devices.

The COM 8116 features an internal crystal oscillator which may be used to provide the master reference frequency. Alternatively, an external reference may be supplied by applying complementary TTL level signals to pins 1 and 18. Parts suitable for use only with an external TTL reference are marked COM 8116T. TTL outputs used to drive the COM 8116 or COM 8116T XTAL/EXT inputs should not be used to drive

other TTL inputs, as noise immunity may be compromised due to excessive loading.

The output of the oscillator/buffer is applied to the dividers for generation of the output frequencies f_r , f_t . The dividers are capable of dividing by any integer from 6 to $2^9 + 1$, inclusive. If the divisor is even, the output will be square; otherwise the output will be high longer than it is low by one f_x clock period.

Each of the two divisor ROMs contains 16 divisors, each 19 bits wide, and is fabricated using SMC's unique CLASP® technology allowing up to 32 different divisors on custom parts. This process permits reduction of turn-around time for ROM patterns. Each group of four divisor select bits is held in an externally strobed data latch. The strobe input is level sensitive: while the strobe is high, data is passed directly through to the ROM. Initiation of a new frequency is effected within 3.5 μ s of a change in any of the four divisor select bits (strobe activity is not required). The divisor select inputs have pull-up resistors; the strobe inputs do not.

Description of Pin Functions

Pin No.	Symbol	Name	Function
1	XTAL/EXT1	Crystal or External Input 1	This input is either one pin of the crystal package or one polarity of the external input.
2	V _{CC}	Power Supply	+5 volt supply
3	f _r	Receiver Output Frequency	This output runs at a frequency selected by the Receiver divisor select data bits.
4-7	R _A , R _B , R _C , R _D	Receiver-Divisor Select Data Bits	The logic level on these inputs, as shown in Table 1, selects the receiver output frequency, f _r .
8	STR	Strobe-Receiver	A high level input strobe loads the receiver data (R _A , R _B , R _C , R _D) into the receiver divisor select register. This input may be strobed or hard-wired to a high level.
9	NC	No Connection	
10	NC	No Connection	
11	GND	Ground	Ground
12	STT	Strobe-Transmitter	A high level input strobe loads the transmitter data (T _A , T _B , T _C , T _D) into the transmitter divisor select register. This input may be strobed or hard-wired to a high level.
13-16	T _D , T _C , T _B , T _A	Transmitter-Divisor Select Data Bits	The logic level on these inputs, as shown in Table 1, selects the transmitter output frequency, f _t .
17	f _t	Transmitter Output Frequency	This output runs at a frequency selected by the Transmitter divisor select data bits.
18	XTAL/EXT2	Crystal or External Input 2	This input is either the other pin of the crystal package or the other polarity of the external input.

For electrical characteristics, see page 189.

ELECTRICAL CHARACTERISTICS COM8046, COM8046T, COM8116, COM8116T, COM8126, COM8126T, COM8136, COM8136T, COM8146, COM8146T

MAXIMUM GUARANTEED RATINGS*

Operating Temperature Range	0°C to + 70°C
Storage Temperature Range	-55°C to +150°C
Lead Temperature (soldering, 10 sec.)	+325°C
Positive Voltage on any Pin, with respect to ground	+8.0V
Negative Voltage on any Pin, with respect to ground	-0.3V

*Stresses above those listed may cause permanent damage to the device. This is a stress rating only and functional operation of the device at these or at any other condition above those indicated in the operational sections of this specification is not implied.

NOTE: When powering this device from laboratory or system power supplies, it is important that the Absolute Maximum Ratings not be exceeded or device failure can result. Some power supplies exhibit voltage spikes or "glitches" on their outputs when the AC power is switched on and off. In addition, voltage transients on the AC power line may appear on the DC output. If this possibility exists it is suggested that a clamp circuit be used.

ELECTRICAL CHARACTERISTICS (T_A=0°C to 70°C, V_{CC}=+5V±5%, unless otherwise noted)

Parameter	Min.	Typ.	Max.	Unit	Comments
D.C. CHARACTERISTICS					
INPUT VOLTAGE LEVELS					
Low-level, V _{IL}			0.8	V	
High-level, V _{IH}	2.0			V	excluding XTAL inputs
OUTPUT VOLTAGE LEVELS					
Low-level, V _{OL}			0.4	V	I _{OL} = 1.6mA, for f _X /4, f _O /16
			0.4	V	I _{OL} = 3.2mA, for f _O , f _R , f _T
			0.4	V	I _{OL} = 0.8mA, for f _X
High-level, V _{OH}	3.5			V	I _{OH} = -100μA; for f _X , I _{OH} = -50μA
INPUT CURRENT					
Low-level, I _{IC}			-0.1	mA	V _{IN} = GND, excluding XTAL inputs
INPUT CAPACITANCE					
All inputs, C _{IN}		5	10	pF	V _{IN} = GND, excluding XTAL inputs
EXT INPUT LOAD					
		8	10		Series 7400 equivalent loads
POWER SUPPLY CURRENT					
I _{CC}			50	mA	
A.C. CHARACTERISTICS					
T _A = +25°C					
CLOCK FREQUENCY, f_{IN}					
	0.01		7.0	MHz	XTAL/EXT, 50% Duty Cycle ±5%
					COM 8046, COM 8126, COM 8146
	0.01		5.1	MHz	XTAL/EXT, 50% Duty Cycle ±5%
					COM 8116, COM 8136
STROBE PULSE WIDTH, t_{pw}					
	150		DC	ns	
INPUT SET-UP TIME					
t _{DS}	200			ns	
INPUT HOLD TIME					
t _{DH}	50			ns	
STROBE TO NEW FREQUENCY DELAY					
			3.5	μs	@ f _X = 5.0 MHz

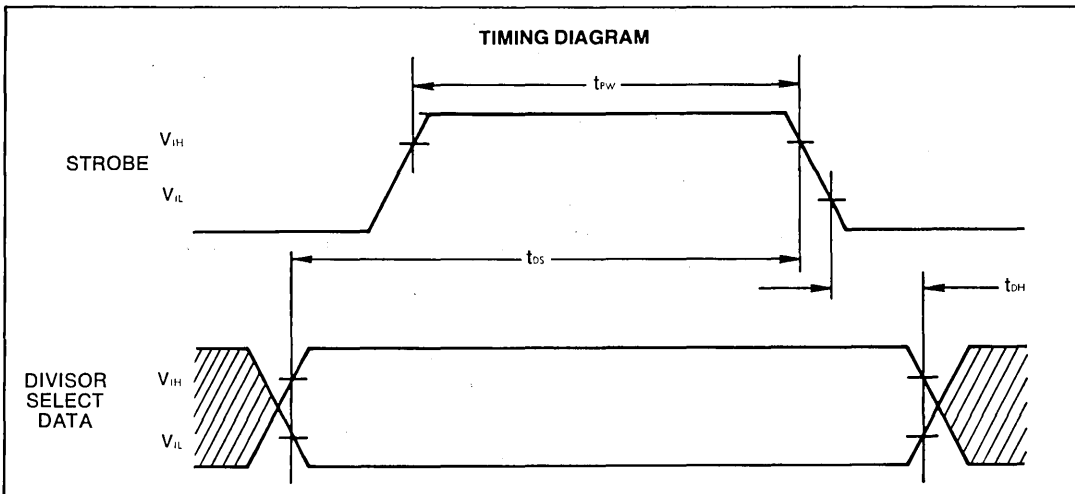

SECTION IV

Crystal Operation
COM 8116
COM 8136

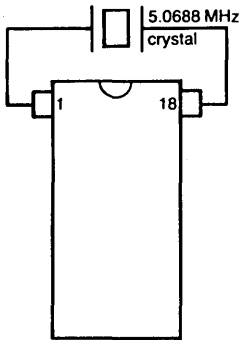

External Input Operation
COM 8116/COM 8116T
COM 8136/COM 8136T

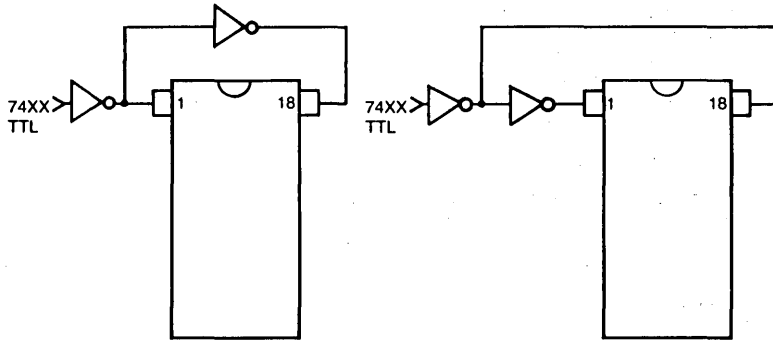

74XX—totem pole or open collector output (external pull-up resistor required)

Crystal Operation
COM 8126
COM 8146
COM 8046

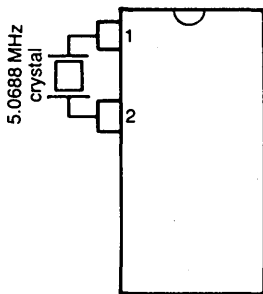

External Input Operation
COM 8126/COM 8126T
COM 8146/COM 8146T
COM 8046/COM 8046T

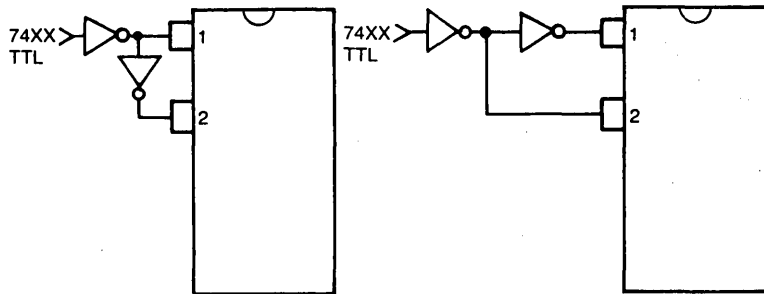

74XX—totem pole or open collector output (external pull-up resistor required)

For ROM re-programming SMC has a computer program available whereby the customer need only supply the input frequency and the desired output frequencies. The ROM programming is automatically generated.

Crystal Specifications

User must specify termination (pin, wire, other)
Prefer: HC-18/U or HC-25/U
Frequency — 5.0688 MHz, AT cut
Temperature range 0°C to 70°C
Series resistance <math>< 50 \Omega</math>
Series Resonant
Overall tolerance $\pm .01\%$
or as required

Crystal manufacturers (Partial List)

Northern Engineering Laboratories
357 Beloit Street
Burlington, Wisconsin 53105
(414) 763-3591

Bulova Frequency Control Products
61-20 Woodside Avenue
Woodside, New York 11377
(212) 335-6000

CTS Knights Inc.
101 East Church Street
Sandwich, Illinois 60548
(815) 786-8411

Crystek Crystals Corporation
1000 Crystal Drive
Fort Myers, Florida 33901
(813) 936-2109

COM 8046

COM 8046T

Table 2
REFERENCE FREQUENCY = 5.068800MHz

Divisor Select EDCBA	Desired Baud Rate	Clock Factor	Desired Frequency (KHz)	Divisor	Actual Baud Rate	Actual Frequency (KHz)	Deviation
00000	50.00	32X	1.60000	3168	50.00	1.600000	0.0000%
00001	75.00	32X	2.40000	2112	75.00	2.400000	0.0000%
00010	110.00	32X	3.52000	1440	110.00	3.520000	0.0000%
00011	134.50	32X	4.30400	1177	134.58	4.306542	0.0591%
00100	150.00	32X	4.80000	1056	150.00	4.800000	0.0000%
00101	200.00	32X	6.40000	792	200.00	6.400000	0.0000%
00110	300.00	32X	9.60000	528	300.00	9.600000	0.0000%
00111	600.00	32X	19.20000	264	600.00	19.200000	0.0000%
01000	1200.00	32X	38.40000	132	1200.00	38.400000	0.0000%
01001	1800.00	32X	57.60000	88	1800.00	57.600000	0.0000%
01010	2400.00	32X	76.80000	66	2400.00	76.800000	0.0000%
01011	3600.00	32X	115.20000	44	3600.00	115.200000	0.0000%
01100	4800.00	32X	153.60000	33	4800.00	153.600000	0.0000%
01101	7200.00	32X	230.40000	22	7200.00	230.400000	0.0000%
01110	9600.00	32X	307.20000	16	9900.00	316.800000	3.1250%
01111	19200.00	32X	614.40000	8	19800.00	633.600000	3.1250%
10000	50.00	16X	0.80000	6336	50.00	0.800000	0.0000%
10001	75.00	16X	1.20000	4224	75.00	1.200000	0.0000%
10010	110.00	16X	1.76000	2880	110.00	1.760000	0.0000%
10011	134.50	16X	2.15200	2355	134.52	2.152357	0.0166%
10100	150.00	16X	2.40000	2112	150.00	2.400000	0.0000%
10101	300.00	16X	4.80000	1056	300.00	4.800000	0.0000%
10110	600.00	16X	9.60000	528	600.00	9.600000	0.0000%
10111	1200.00	16X	19.20000	264	1200.00	19.200000	0.0000%
11000	1800.00	16X	28.80000	176	1800.00	28.800000	0.0000%
11001	2000.00	16X	32.00000	158	2005.06	32.081013	0.2532%
11010	2400.00	16X	38.40000	132	2400.00	38.400000	0.0000%
11011	3600.00	16X	57.60000	88	3600.00	57.600000	0.0000%
11100	4800.00	16X	76.80000	66	4800.00	76.800000	0.0000%
11101	7200.00	16X	115.20000	44	7200.00	115.200000	0.0000%
11110	9600.00	16X	153.60000	33	9600.00	153.600000	0.0000%
11111	19200.00	16X	307.20000	16	19800.00	316.800000	3.1250%

**COM 8116
COM 8116T**

**COM 8126
COM 8126T**

**COM 8136
COM 8136T**

**COM 8146
COM 8146T**

Table 1
REFERENCE FREQUENCY = 5.068800MHZ
(STANDARD PART)

Divisor Select DCBA	Desired Baud Rate	Clock Factor	Desired Frequency (KHz)	Divisor	Actual Baud Rate	Actual Frequency (KHz)	Deviation
0000	50.00	16X	0.80000	6336	50.00	0.800000	0.0000%
0001	75.00	16X	1.20000	4224	75.00	1.200000	0.0000%
0010	110.00	16X	1.76000	2880	110.00	1.760000	0.0000%
0011	134.50	16X	2.15200	2355	134.52	2.152357	0.0166%
0100	150.00	16X	2.40000	2112	150.00	2.400000	0.0000%
0101	300.00	16X	4.80000	1056	300.00	4.800000	0.0000%
0110	600.00	16X	9.60000	528	600.00	9.600000	0.0000%
0111	1200.00	16X	19.20000	264	1200.00	19.200000	0.0000%
1000	1800.00	16X	28.80000	176	1800.00	28.800000	0.0000%
1001	2000.00	16X	32.00000	158	2005.06	32.081013	0.2532%
1010	2400.00	16X	38.40000	132	2400.00	38.400000	0.0000%
1011	3600.00	16X	57.60000	88	3600.00	57.600000	0.0000%
1100	4800.00	16X	76.80000	66	4800.00	76.800000	0.0000%
1101	7200.00	16X	115.20000	44	7200.00	115.200000	0.0000%
1110	9600.00	16X	153.60000	33	9600.00	153.600000	0.0000%
1111	19200.00	16X	307.20000	16	19800.00	316.800000	3.1250%

Table 2
REFERENCE FREQUENCY = 4.915200MHz
(COM81 — — —5)

Divisor Select DCBA	Desired Baud Rate	Clock Factor	Desired Frequency (KHz)	Divisor	Actual Baud Rate	Actual Frequency (KHz)	Deviation
0000	50.00	16X	0.80000	6144	50.00	0.800000	0.0000%
0001	75.00	16X	1.20000	4096	75.00	1.200000	0.0000%
0010	110.00	16X	1.76000	2793	109.93	1.758983	0.0100%
0011	134.50	16X	2.15200	2284	134.50	2.152000	0.0000%
0100	150.00	16X	2.40000	2048	150.00	2.400000	0.0000%
0101	300.00	16X	4.80000	1024	300.00	4.800000	0.0000%
0110	600.00	16X	9.60000	512	600.00	9.600000	0.0000%
0111	1200.00	16X	19.20000	256	1200.00	19.200000	0.0000%
1000	1800.00	16X	28.80000	171	1796.49	28.743859	0.1949%
1001	2000.00	16X	32.00000	154	1994.81	31.916883	0.2597%
1010	2400.00	16X	38.40000	128	2400.00	32.000000	0.0000%
1011	3600.00	16X	57.60000	85	3614.11	57.825882	0.3921%
1100	4800.00	16X	76.80000	64	4800.00	76.800000	0.0000%
1101	7200.00	16X	115.20000	43	7144.19	114.306976	0.7751%
1110	9600.00	16X	153.60000	32	9600.00	153.600000	0.0000%
1111	19200.00	16X	307.20000	16	19200.00	307.200000	0.0000%

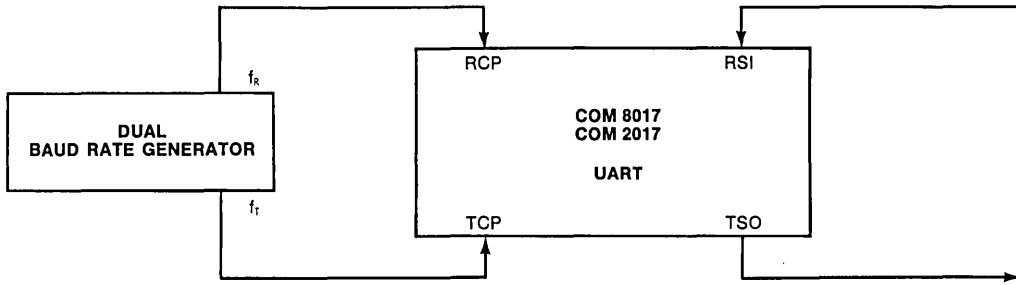

Typical UART—Dual Baud Rate Generator Configuration
Full Duplex—Split Speed

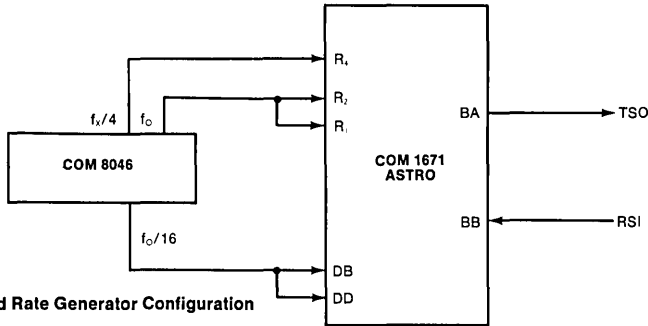

Typical ASTRO—Baud Rate Generator Configuration

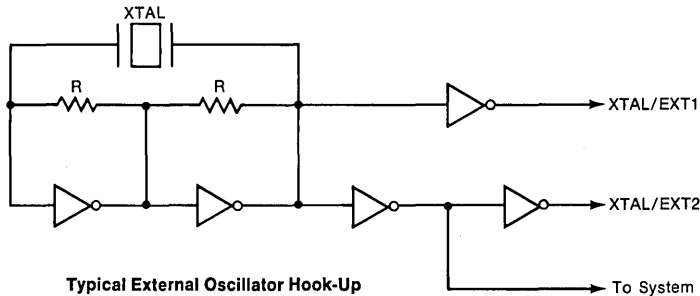

Typical External Oscillator Hook-Up

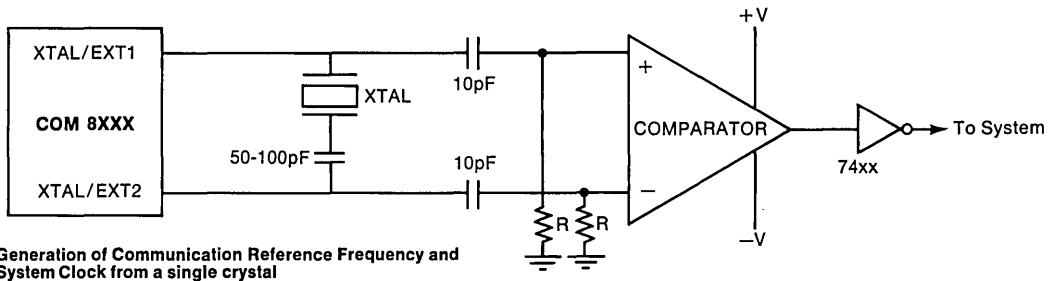

Generation of Communication Reference Frequency and
System Clock from a single crystal