

COP884BC/COP885BC 8-Bit CMOS ROM Based Microcontrollers with 2k Memory, Comparators, and CAN Interface

General Description

The COP884BC ROM based microcontrollers are highly integrated COP8™ Feature core devices with 2k memory and advanced features including a CAN 2.0B (passive) interface and two Analog comparators. These single-chip CMOS devices are suited for applications requiring a full featured controller with a CAN interface, low EMI, and an 8-bit 39 kHz PWM timer. COP87L84BC devices are pin and software compatible 16k OTP (One Time Programmable) versions for pre-production, and for use with a range of COP8 software and hardware development tools.

Features include an 8-bit memory mapped architecture, 10 MHz CKI (crystal osc) with 1 μ s instruction cycle, one multi-function 16-bit timer/counter, 8-bit 39 kHz PWM timer with 2 outputs, CAN 2.0B (passive) interface, MICROWIRE/PLUS™ serial I/O, two Analog comparators, two power saving HALT/IDLE modes, idle timer, MIWU, software selectable I/O options, Power on Reset, low EMI 4.5V to 5.5V operation, and 20/28 pin packages.

Note: A companion device with CAN interface, more I/O and memory, A/D, and USART is the COP888EB.

Devices included in this datasheet are:

Device	Memory (bytes)	RAM (bytes)	I/O Pins	Packages	Temperature
COP684BC	2k ROM	64	18	28 SOIC	-55 to +125°C
COP884BC	2k ROM	64	18	28 SOIC	-40 to +85°C
COP685BC	2k ROM	64	10	20 SOIC	-55 to +125°C
COP885BC	2k ROM	64	10	20 SOIC	-40 to +85°C

Key Features

- CAN 2.0B (passive) Interface
- Power On Reset (selectable)
- One 16-bit timer, with two 16-bit registers supporting:
 - Processor Independent PWM mode
 - External Event counter mode
 - Input Capture mode
- High speed, constant resolution 8-bit PWM/frequency monitor timer with 2 output pins
- 2048 bytes on-board ROM
- 64 bytes on-board RAM

Additional Peripheral Features

- Idle Timer
- Multi-Input Wake Up (MIWU) with optional interrupts (7)
- Two analog comparators
- MICROWIRE/PLUS serial I/O

I/O Features

- Memory mapped I/O
- Software selectable I/O options (TRI-STATE® Output, Push-Pull Output, Weak Pull-Up Input, High Impedance Input)
- Schmitt trigger inputs on ports G and L
- Packages: 28 SO with 18 I/O pins and 20 SO with 10 I/O pins

CPU/Instruction Set Features

- 1 μ s instruction cycle time
- Eleven multi-source vectored interrupts servicing
 - External Interrupt
 - Idle Timer T0
 - Timer T1 (with 2 Interrupts)
 - MICROWIRE/PLUS
 - Multi-Input Wake Up
 - Software Trap
 - PWM Timer
 - CAN Interface (with 3 interrupts)
- Versatile and easy to use instruction set
- 8-bit Stack Pointer (SP) — stack in RAM
- Two 8-bit Register Indirect Data Memory Pointers (B and X)

Fully Static CMOS

- Two power saving modes: HALT and IDLE
- Low current drain (typically <1 μ A)
- Single supply operation: 4.5V–5.5V
- Temperature ranges: –40°C to +85°C, –55°C to +125°C

Development Support

- Emulation and OTP devices
- Real time emulation and full program debug offered by MetaLink Development Systems

COP8™, and MICROWIRE/PLUS™ are trademarks of National Semiconductor Corporation. TRI-STATE® is a registered trademark of National Semiconductor Corporation. iceMASTER® is a registered trademark of MetaLink Corporation.

Block Diagram

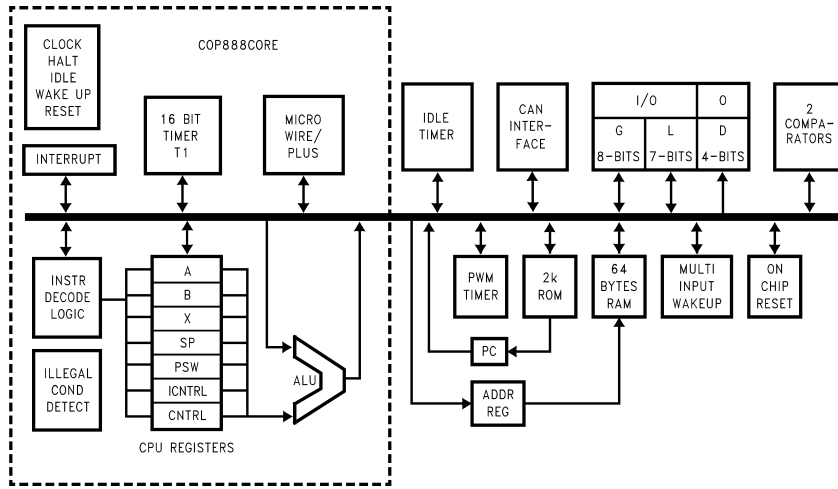

DS012067-1

FIGURE 1. Block Diagram

Connection Diagrams

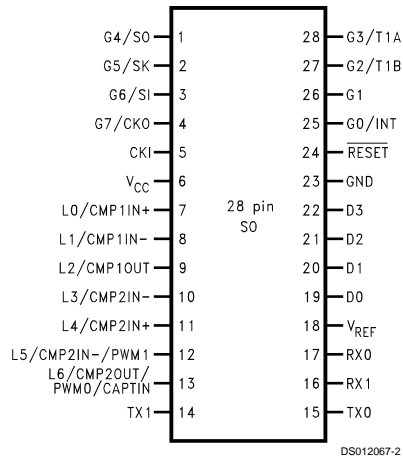

Top View

Order Number COP884BC-xxx/WM or
COP684BC-xxx/WM
See NS Package Number M28B

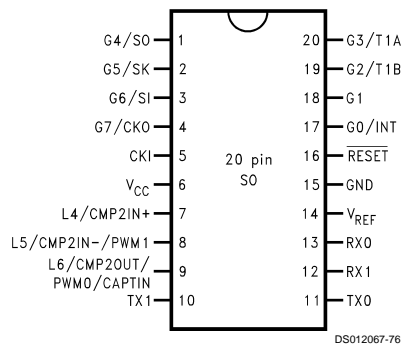

Top View

Order Number COP885BC-xxx/WM or
COP685BC-xxx/WM
See NS Package Number M20B

FIGURE 2. Connection Diagrams

Pinouts for 28-SO Package

Port Pin	Type	Alt. Function	20-Pin SO	28-Pin SO
G0	I/O	INTR	17	25
G1	I/O		18	26
G2	I/O	T1B	19	27
G3	I/O	T1A	20	28
G4	I/O	SO	1	1
G5	I/O	SK	2	2
G6	I	SI	3	3
G7	I	CKO	4	4
L0	I/O	CMP1IN+/MIWU		7
L1	I/O	CMP1IN-/MIWU		8
L2	I/O	CMP10UT/MIWU		9
L3	I/O	CMP2IN-/MIWU		10
L4	I/O	CMP2IN+/MIWU	7	11
L5	I/O	CMP2IN-/PWM1/MIWU	8	12
L6	I/O	CMP2OUT/PWM0/CAPTIN/MIWU	9	13
D0	O			19
D1	O			20
D2	O			21
D3	O			22
CAN V _{REF}			14	18
CAN Tx0	O		11	15
CAN Tx1	O		10	14
CAN Rx0	I	MIWU (Note 1)	13	17
CAN Rx1	I	MIWU	12	16
V _{CC}			6	6
GND			15	23
CKI	I		5	5
RESET	I		16	24

Note 1: The MIWU function for the CAN interface is internal (see CAN interface block diagram)

Absolute Maximum Ratings (Note 2)

If Military/Aerospace specified devices are required, please contact the National Semiconductor Sales Office/Distributors for availability and specifications.

Supply Voltage (V_{CC}) 6V
Voltage at Any Pin $-0.3V$ to $V_{CC} + 0.3V$

Total Current into V_{CC} Pin (Source) 90 mA
Total Current out of GND Pin (Sink) 100 mA
Storage Temperature Range $-65^{\circ}C$ to $+150^{\circ}C$

Note 2: Absolute maximum ratings indicate limits beyond which damage to the device may occur. DC and AC electrical specifications are not ensured when operating the device at absolute maximum ratings.

DC Electrical Characteristics COP884BC:

$-40^{\circ}C \leq T_A \leq +85^{\circ}C$

Parameter	Conditions	Min	Typ	Max	Units
Operating Voltage		4.5		5.5	V
Power Supply Ripple (Note 3)	Peak-to-Peak			$0.1 V_{CC}$	V
Supply Current				15	mA
CKI = 10 MHz (Note 4)	$V_{CC} = 5.5V, t_c = 1 \mu s$				
HALT Current (Notes 5, 6)	$V_{CC} = 5.5V, CKI = 0 MHz$ Power-On Reset Enabled		<300	480	μA
	Power-On Reset Disabled		<250	380	μA
IDLE Current (Note 6)				5.5	mA
CKI = 10 MHz	$V_{CC} = 5.5V, t_c = 1 \mu s$				
Input Levels (V_{IH}, V_{IL})					
Reset, CKI					
Logic High		$0.8 V_{CC}$			V
Logic Low				$0.2 V_{CC}$	V
All Other Inputs					
Logic High		$0.7 V_{CC}$			V
Logic Low				$0.2 V_{CC}$	V
Hi-Z Input Leakage	$V_{CC} = 5.5V$			± 2	μA
Input Pull-up Current	$V_{CC} = 5.5V, V_{IN} = 0V$	-40		-250	μA
G and L Port Input Hysteresis	(Notes 9, 10)		$0.05 V_{CC}$		V
Output Current Levels D Outputs					
Source	$V_{CC} = 4.5V, V_{OH} = 3.3V$	-0.4			mA
Sink	$V_{CC} = 4.5V, V_{OL} = 1.0V$	10			mA
Comparator Output (L2, L6)					
Source (Push-Pull)	$V_{CC} = 4.5V, V_{OH} = 3.3V$	-1.6			mA
Sink (Push-Pull)	$V_{CC} = 4.5V, V_{OL} = 0.4V$	1.6			mA
CAN Transmitter Outputs					
Source (Tx1)	$V_{CC} = 4.5V, V_{OH} = V_{CC} - 0.1V$	-1.5			mA
	$V_{CC} = 4.5V, V_{OH} = V_{CC} - 0.6V$	-10			mA
Sink (Tx0)	$V_{CC} = 4.5V, V_{OL} = 0.1V$	1.5			mA
	$V_{CC} = 4.5V, V_{OL} = 0.6V$	10			mA
All Others					
Source (Weak Pull-Up)	$V_{CC} = 4.5V, V_{OH} = 2.7V$	-10		-110	μA
Source (Push-Pull)	$V_{CC} = 4.5V, V_{OH} = 3.3V$	-0.4			mA
Sink (Push-Pull)	$V_{CC} = 4.5V, V_{OL} = 0.4V$	1.6			mA
TRI-STATE Leakage	$V_{CC} = 5.5V$			± 2.0	μA
Allowable Sink/Source Current per Pin					
D Outputs (Sink)				15	mA
Tx0 (Sink) (Note 10)				30	mA
Tx1 (Source) (Note 10)				30	mA
All Other				3	mA

DC Electrical Characteristics COP884BC: (Continued)

$-40^{\circ}\text{C} \leq T_A \leq +85^{\circ}\text{C}$

Parameter	Conditions	Min	Typ	Max	Units
Maximum Input Current without Latchup (Notes 8, 10)	Room Temp			± 100	mA
RAM Retention Voltage, V_r (Note 9)	500 ns Rise and Fall Time	2.0			V
Input Capacitance	(Note 10)			7	pF
Load Capacitance on D2				1000	pF

Note 3: Maximum rate of voltage change must be less than 0.5 V/ms

Note 4: Supply current is measured after running 2000 cycles with a square wave CKI input, CKO open, inputs at V_{CC} or GND, and outputs open.

Note 5: The HALT mode will stop CKI from oscillating in the Crystal configurations. Halt test conditions: All inputs tied to V_{CC} ; L, and G port I/Os configured as outputs and programmed low; D outputs programmed low. Parameter refers to HALT mode entered via setting bit 7 of the G Port data register. Part will pull up CKI during HALT in crystal clock mode.

Note 6: HALT and IDLE current specifications assume CAN block and comparators are disabled.

Absolute Maximum Ratings (Note 7)

If Military/Aerospace specified devices are required, please contact the National Semiconductor Sales Office/Distributors for availability and specifications.

Supply Voltage (V_{CC}) 7V
Voltage at Any Pin $-0.3V$ to $V_{CC} + 0.3V$

Total Current into V_{CC} Pin (Source) 100 mA
Total Current out of GND Pin (Sink) 110 mA
Storage Temperature Range $-65^{\circ}C$ to $+150^{\circ}C$

Note 7: Absolute maximum ratings indicate limits beyond which damage to the device may occur. DC and AC electrical specifications are not ensured when operating the device at absolute maximum ratings.

DC Electrical Characteristics COP684BC:

$-55^{\circ}C \leq T_A \leq +125^{\circ}C$

Parameter	Conditions	Min	Typ	Max	Units
Operating Voltage		4.5		5.5	V
Power Supply Ripple (Note 3)	Peak-to-Peak			$0.1 V_{CC}$	V
Supply Current				15	mA
CKI = 10 MHz (Note 4)	$V_{CC} = 5.5V, t_c = 1 \mu s$				
HALT Current (Notes 5, 6)	$V_{CC} = 5.5V, CKI = 0$ MHz Power-On Reset Enabled		<300	480	μA
	Power-On Reset Disabled		<250	380	μA
IDLE Current (Note 6)					
CKI = 10 MHz	$V_{CC} = 5.5V, t_c = 1 \mu s$			5.5	mA
Input Levels (V_{IH}, V_{IL})					
Reset, CKI					
Logic High		$0.8 V_{CC}$			V
Logic Low				$0.2 V_{CC}$	V
All Other Inputs					
Logic High		$0.7 V_{CC}$			V
Logic Low				$0.2 V_{CC}$	V
Hi-Z Input Leakage	$V_{CC} = 5.5V$			± 5	μA
Input Pull-up Current	$V_{CC} = 5.5V, V_{IN} = 0V$	-35		-250	μA
G and L Port Input Hysteresis	(Note 9)		$0.05 V_{CC}$		V
Output Current Levels D Outputs					
Source	$V_{CC} = 4.5V, V_{OH} = 3.3V$	-0.4			mA
Sink	$V_{CC} = 4.5V, V_{OL} = 1.0V$	9.0			mA
Comparator Output (L2, L6)					
Source (Push-Pull)	$V_{CC} = 4.5V, V_{OH} = 3.3V$	-1.6			mA
Sink (Push-Pull)	$V_{CC} = 4.5V, V_{OL} = 0.4V$	1.6			mA
CAN Transmitter Outputs					
Source (Tx1)	$V_{CC} = 4.5V, V_{OH} = V_{CC} - 0.1V$	-1.5			mA
	$V_{CC} = 4.5V, V_{OH} = V_{CC} - 0.6V$	-10			mA
Sink (Tx0)	$V_{CC} = 4.5V, V_{OL} = 0.1V$	1.5			mA
	$V_{CC} = 4.5V, V_{OL} = 0.6V$	10			mA
All Others					
Source (Weak Pull-Up)	$V_{CC} = 4.5V, V_{OH} = 2.7V$	-9.0		-100	μA
Source (Push-Pull)	$V_{CC} = 4.5V, V_{OH} = 3.3V$	-0.4			mA
Sink (Push-Pull)	$V_{CC} = 4.5V, V_{OL} = 0.4V$	1.4			mA
TRI-STATE Leakage	$V_{CC} = 5.5V$			± 5.0	μA
Allowable Sink/Source Current per Pin					
D Outputs (Sink)				12	mA
Tx0 (Sink) (Note 10)				30	mA
Tx1 (Source) (Note 10)				30	mA
All Other				2.5	mA

DC Electrical Characteristics COP684BC: (Continued)

$-55^{\circ}\text{C} \leq T_A \leq +125^{\circ}\text{C}$

Parameter	Conditions	Min	Typ	Max	Units
Maximum Input Current without Latchup (Notes 8, 10)	Room Temp			± 100	mA
RAM Retention Voltage, V_r (Note 9)	500 ns Rise and Fall Time	2.0			V
Input Capacitance	(Note 10)			7	pF
Load Capacitance on D2				1000	pF

Note 8: Pins G6 and RESET are designed with a high voltage input network. These pins allow input voltages greater than V_{CC} and the pins will have sink current to V_{CC} when biased at voltages greater than V_{CC} (the pins do not have source current when biased at a voltage below V_{CC}). The effective resistance to V_{CC} is 750 Ω (typical). These two pins will not latch up. The voltage at the pins must be limited to less than 14V.

Note 9: Condition and parameter valid only for part in HALT mode.

Note 10: Parameter characterized but not tested.

AC Electrical Characteristics COP684BC and COP884BC:

$-55^{\circ}\text{C} \leq T_A \leq +125^{\circ}\text{C}$

Parameter	Conditions	Min	Typ	Max	Units
Instruction Cycle Time (t_c) Crystal/Resonator	$V_{CC} \geq 4.5\text{V}$	1.0		DC	μs
Inputs					
t_{SETUP}	$V_{CC} \geq 4.5\text{V}$	200			ns
t_{HOLD}	$V_{CC} \geq 4.5\text{V}$	60			ns
PWM Capture Input					
t_{SETUP}	$V_{CC} \geq 4.5\text{V}$	30			ns
t_{HOLD}	$V_{CC} \geq 4.5\text{V}$	70			ns
Output Propagation Delay (t_{PD1} , t_{PD0}) (Note 12) SK, SO PWM Outputs All Others	$C_L = 100\text{ pF}$, $R_L = 2.2\text{ k}\Omega$ $V_{CC} \geq 4.5\text{V}$ $V_{CC} \geq 4.5\text{V}$ $V_{CC} \geq 4.5\text{V}$			0.7 75 1	μs ns μs
MICROWIRE					
Setup Time (t_{UWS}) (Note 13)		20			ns
Hold Time (t_{UWH}) (Note 13)		56			ns
Output Prop Delay (t_{UPD})				220	ns
Input Pulse Width (Note 14)					
Interrupt High Time		1			t_c
Interrupt Low Time		1			t_c
Timer 1,2 High Time		1			t_c
Timer 1,2 Low Time		1			t_c
Reset Pulse Width (Note 13)		1.0			μs
Power Supply Rise Time for Proper Operation of On-Chip RESET		50 μs		256 $\cdot t_c$	

Note 11: For device testing purposes of all AC parameters, V_{OH} will be tested at $0.5 \cdot V_{CC}$.

Note 12: The output propagation delay is referenced to the end of the instruction cycle where the output change occurs.

Note 13: Parameter not tested.

Note 14: t_c = Instruction Cycle Time.

On-Chip Voltage Reference:

$-55^{\circ}\text{C} \leq T_A \leq +125^{\circ}\text{C}$

Parameter	Conditions	Min	Max	Units
Reference Voltage V_{REF}	$I_{OUT} < 80 \mu\text{A}$, $V_{CC} = 5\text{V}$	$0.5 V_{CC} - 0.12$	$0.5 V_{CC} + 0.12$	V
Reference Supply Current, I_{DD}	$I_{OUT} = 0\text{A}$, (No Load) $V_{CC} = 5\text{V}$ (Note 15)		120	μA

Note 15: Reference supply I_{DD} is supplied for information purposes only, it is not tested.

Comparator DC/AC Characteristics:

$4.5\text{V} \leq V_{CC} \leq 5.5\text{V}$, $-55^{\circ}\text{C} \leq T_A \leq +125^{\circ}\text{C}$

Parameter	Conditions	Min	Typ	Max	Units
Input Offset Voltage	$0.4\text{V} < V_{IN} < V_{CC} - 1.5\text{V}$		± 10	± 25	mV
Input Common Mode Voltage Range		0.4		$V_{CC} - 1.5$	V
Voltage Gain			300k		V/V
Outputs Sink/Source	See I/O-Port DC Specifications				
DC Supply Current (when enabled)	$V_{CC} = 6.0\text{V}$			250	μA
Response Time	TBD mV Step, TBD mV Overdrive, 100 pF Load		1		μs

CAN Comparator DC and AC Characteristics:

$4.8\text{V} \leq V_{CC} \leq 5.2\text{V}$, $-40^{\circ}\text{C} \leq T_A \leq +125^{\circ}\text{C}$

Parameters	Conditions	Min	Typ	Max	Units
Differential Input Voltage				± 25	mV
Input Offset Voltage	$1.5\text{V} < V_{IN} < V_{CC} - 1.5\text{V}$			± 10	mV
Input Common Mode Voltage Range		1.5		$V_{CC} - 1.5$	V
Input Hysteresis		8			mV

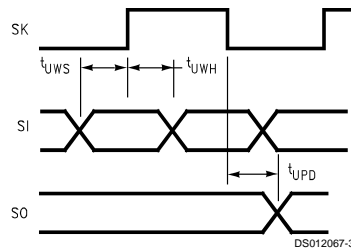

FIGURE 3. MICROWIRE/PLUS Timing Diagram

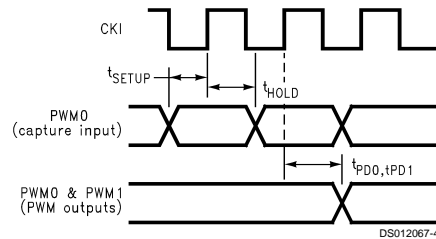
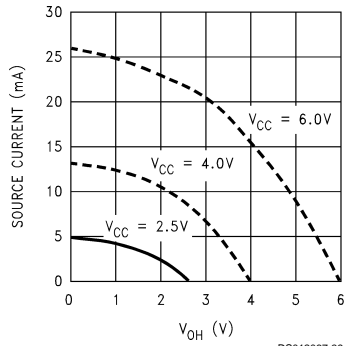

FIGURE 4. PWM/CAPTURE Timer Input/Output Timing Diagram

Typical Performance Characteristics $-55^{\circ}\text{C} \leq T_A \leq +125^{\circ}\text{C}$

Port D Source Current



DS012067-39

Port D Sink Current

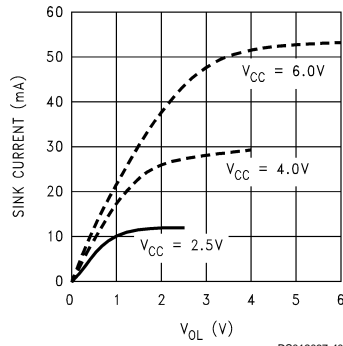

DS012067-40

Ports G/L Source Current

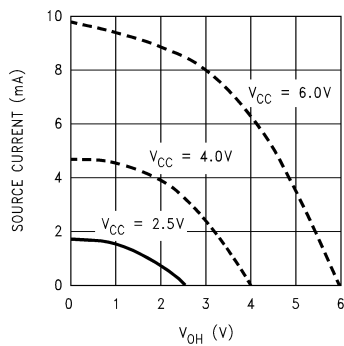

DS012067-41

Port G/L Sink Current

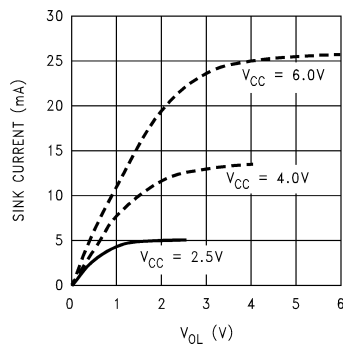

DS012067-42

Ports G/L Weak Pull-Up Source Current

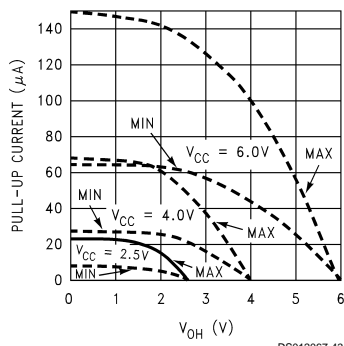

DS012067-43

Dynamic I_{DD} vs V_{CC}

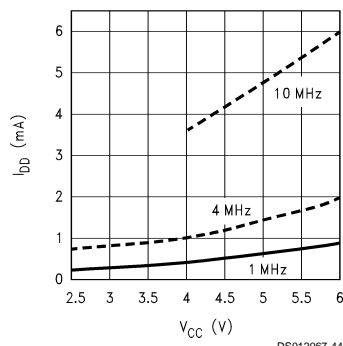

DS012067-44

Typical Performance Characteristics $-55^{\circ}\text{C} \leq T_A \leq +125^{\circ}\text{C}$ (Continued)

Idle I_{DD} vs V_{CC}

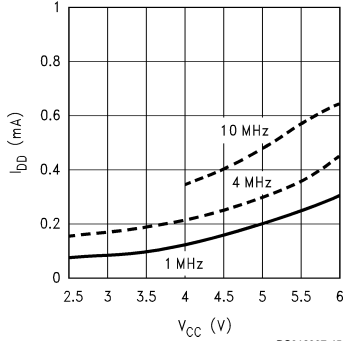

Halt Supply Current

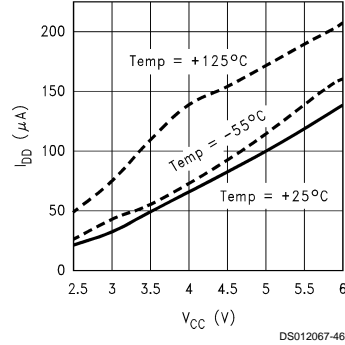

CAN Tx0 Sink Current

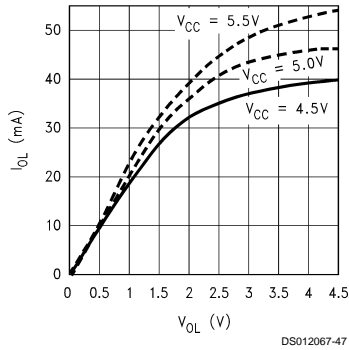

CAN Tx1 Source Current

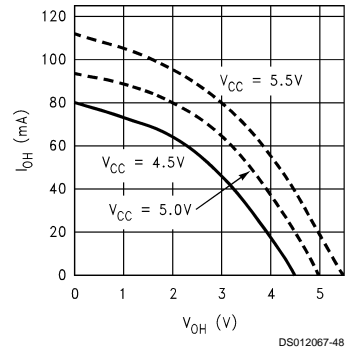

Pin Descriptions

V_{CC} and GND are the power supply pins.

CKI is the clock input. The clock can come from a crystal oscillator (in conjunction with CKO). See Oscillator Description section.

$\overline{\text{RESET}}$ is the master reset input. See Reset Description section.

The device contains one bidirectional 8-bit I/O port (G), and one 7-bit bidirectional I/O port (L) where each individual bit may be independently configured as an input (Schmitt trigger inputs on ports G and L), output or TRI-STATE[®] under program control. Three data memory address locations are allocated for each of these I/O ports. Each I/O port has two associated 8-bit memory mapped registers, the CONFIGURATION register and the output DATA register. A memory mapped address is also reserved for the input pins of each I/O port. (See the memory map for the various addresses associated with the I/O ports.) Figure 5 shows the I/O port configurations for the device. The DATA and CONFIGURATION registers allow for each port bit to be individually configured under software control as shown below:

Configuration Register	Data Register	Port Set-Up
0	0	Hi-Z Input (TRI-STATE Output)
0	1	Input with Weak Pull-Up
1	0	Push-Pull Zero Output
1	1	Push-Pull One Output

PORT L is a 7-bit I/O port. All L-pins have Schmitt triggers on the inputs.

Port L supports Multi-Input Wake Up (MIWU) on all seven pins.

Port L has the following alternate features:

L6 MIWU or CMP2OUT or PWM0 or CAPTIN

L5 MIWU or CMP2IN- or PWM1

L4 MIWU or CMP2IN+

L3 MIWU or CMP2IN-

L2 MIWU or CMP1OUT

L1 MIWU or CMP1IN-

L0 MIWU or CMP1IN+

Port G is an 8-bit port with 5 I/O pins (G0–G5), an input pin (G6), and one dedicated output pin (G7). Pins G0–G6 all have Schmitt Triggers on their inputs. G7 serves as the dedicated output pin for the CKO clock output. There are two reg-

Pin Descriptions (Continued)

isters associated with the G Port, a data register and a configuration register. Therefore, each of the 6 I/O bits (G0–G5) can be individually configured under software control.

Since G6 is an input only pin and G7 is the dedicated CKO clock output pin the associated bits in the data and configuration registers for G6 and G7 are used for special purpose functions as outlined below. Reading the G6 and G7 data bits will return zeroes.

Note that the chip will be placed in the HALT mode by writing a “1” to bit 7 of the Port G Data Register. Similarly the chip will be placed in the IDLE mode by writing a “1” to bit 6 of the Port G Data Register.

Writing a “1” to bit 6 of the Port G Configuration Register enables the MICROWIRE/PLUS to operate with the alternate phase of the SK clock.

	Config. Register	Data Register
G7		HALT
G6	Alternate SK	IDLE

CAN pins: For the on-chip CAN interface this device has five dedicated pins with the following features:

V_{REF}	On-chip reference voltage with the value of $V_{CC}/2$
Rx0	CAN receive data input pin.
Rx1	CAN receive data input pin.
Tx0	CAN transmit data output pin. This pin may be put in the TRI-STATE mode with the TXEN0 bit in the CAN Bus control register.
Tx1	CAN transmit data output pin. This pin may be put in the TRI-STATE mode with the TXEN1 bit in the CAN Bus control register.

Port G has the following alternate features:

G6	SI (MICROWIRE Serial Data Input)
G5	SK (MICROWIRE Serial Clock)
G4	SO (MICROWIRE Serial Data Output)
G3	T1A (Timer T1 I/O)
G2	T1B (Timer T1 Capture Input)
G0	INTR (External Interrupt Input)

Port G has the following dedicated function:

G7	CKO Oscillator dedicated output
----	---------------------------------

Port D is a 4-bit output port that is preset high when RESET goes low. The user can tie two or more D port outputs (except D2) together in order to get a higher drive.

Note: Care must be exercised with the D2 pin operation. At RESET, the external loads on this pin must ensure that the output voltages stay above $0.8 V_{CC}$ to prevent the chip from entering special modes. Also keep the external loading on D2 to less than 1000 pF.

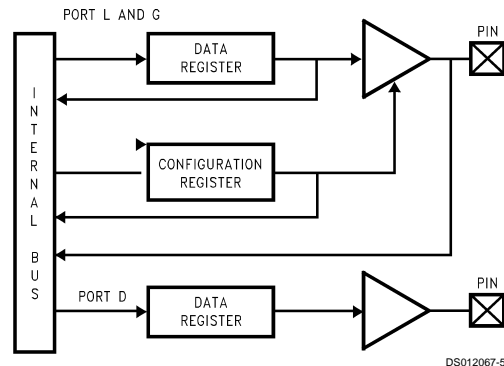

FIGURE 5. I/O Port Configurations

Functional Description

The architecture of the device utilizes a modified Harvard architecture. With the Harvard architecture, the control store program memory (ROM) is separated from the data store memory (RAM). Both ROM and RAM have their own separate addressing space with separate address buses. The architecture, though based on Harvard architecture, permits transfer of data from ROM to RAM.

CPU REGISTERS

The CPU can do an 8-bit addition, subtraction, logical or shift operation in one instruction (t_c) cycle time.

There are five CPU registers:

A is the 8-bit Accumulator Register

PC is the 15-bit Program Counter Register

PU is the upper 7 bits of the program counter (PC)

PL is the lower 8 bits of the program counter (PC)

B is an 8-bit RAM address pointer, which can be optionally post auto incremented or decremented.

X is an 8-bit alternate RAM address pointer, which can be optionally post auto incremented or decremented.

SP is the 8-bit stack pointer, which points to the subroutine/interrupt stack (in RAM). The SP is initialized to RAM address 02F with reset.

All the CPU registers are memory mapped with the exception of the Accumulator (A) and the Program Counter (PC).

PROGRAM MEMORY

Program memory for the device consists of 2048 bytes of ROM. These bytes may hold program instructions or constant data (data tables for the LAID instruction, jump vectors for the JID instruction, and interrupt vectors for the VIS instruction). The program memory is addressed by the 15-bit program counter (PC). All interrupts in the device vector to program memory location 0FF Hex.

DATA MEMORY

The data memory address space includes the on-chip RAM and data registers, the I/O registers (Configuration, Data and Pin), the control registers, the MICROWIRE/PLUS SIO shift register, and the various registers, and counters associated with the timers (with the exception of the IDLE timer). Data memory is addressed directly by the instruction or indirectly by the B, X and SP pointers.

Functional Description (Continued)

The device has 64 bytes of RAM. Sixteen bytes of RAM are mapped as “registers” at addresses 0F0 to 0FF Hex. These registers can be loaded immediately, and also decremented and tested with the DRSZ (decrement register and skip if zero) instruction. The memory pointer registers X, SP, and B are memory mapped into this space at address locations 0FC to 0FE Hex respectively, with the other registers (other than reserved register 0FF) being available for general usage.

The instruction set permits any bit in memory to be set, reset or tested. All I/O and registers (except A and PC) are memory mapped; therefore, I/O bits and register bits can be directly and individually set, reset and tested. The accumulator (A) bits can also be directly and individually tested.

Note: RAM contents are undefined upon power-up.

RESET

The $\overline{\text{RESET}}$ input when pulled low initializes the microcontroller. Initialization will occur whenever the $\overline{\text{RESET}}$ input is pulled low. Upon initialization, the data and configuration registers for Ports L and G, are cleared, resulting in these Ports being initialized to the TRI-STATE mode. Port D is initialized high with $\overline{\text{RESET}}$. The PC, PSW, CNTRL, and ICNTRL control registers are cleared. The Multi-Input Wake Up registers WKEN, WKEDG, and WKPND are cleared. The Stack Pointer, SP, is initialized to 02F Hex.

The following initializations occur with $\overline{\text{RESET}}$:

- Port L: TRI-STATE
- Port G: TRI-STATE
- Port D: HIGH
- PC: CLEARED
- PSW, CNTRL and ICNTRL registers: CLEARED

Accumulator and Timer 1:

- RANDOM after RESET with power already applied
- RANDOM after RESET at power-on

SP (Stack Pointer): Loaded with 2F Hex

CMPSL (Comparator control register): CLEARED

PWMCON (PWM control register): CLEARED

B and X Pointers:

- UNAFFECTED after RESET with power already applied
- RANDOM after RESET at power-up

RAM:

- UNAFFECTED after RESET with power already applied
- RANDOM after RESET at power-up

CAN:

- The CAN Interface comes out of external reset in the “error-active” state and waits until the user’s software sets either one or both of the TXEN0, TXEN1 bits to “1”. After that, the device will not start transmission or reception of a frame until eleven consecutive “recessive” (un-driven) bits have been received. This is done to ensure that the output drivers are not enabled during an active message on the bus.

CSCAL, CTIM, TCNTL, TEC, REC: CLEARED

RTSTAT: CLEARED with the exception of the TBE bit which is set to 1

RID, RIDL, TID, TDLC: RANDOM

ON-CHIP POWER-ON RESET

The device is designed with an on-chip power-on reset circuit which will trigger a $256 t_c$ delay as V_{CC} rises above the minimum RAM retention voltage (V_r). This delay allows the oscillator to stabilize before the device exits the reset state. The contents of data registers and RAM are unknown following an on-chip power-on reset. The external reset takes priority over the on-chip reset and will deactivate the $256 t_c$ delay if in progress.

When using external reset, the external RC network shown in *Figure 6* should be used to ensure that the $\overline{\text{RESET}}$ pin is held low until the power supply to the chip stabilizes.

Under no circumstances should the $\overline{\text{RESET}}$ pin be allowed to float. If the on-chip power-on reset feature is being used, $\overline{\text{RESET}}$ should be connected directly to V_{CC} . Be aware of the Power Supply Rise Time requirements specified in the DC Specifications Table. These requirements must be met for the on-chip power-on reset to function properly.

The on-chip power-on reset circuit may reset the device if the operating voltage (V_{CC}) goes below V_r .

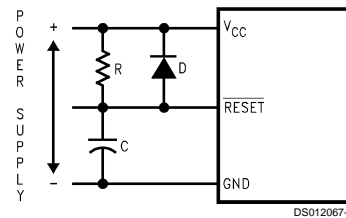

$RC > 5 \times$ Power Supply Rise Time

FIGURE 6. Recommended Reset Circuit

Oscillator Circuits

The chip can be driven by a clock input on the CKI input pin which can be between DC and 10 MHz. The CKO output clock is on pin G7. The CKI input frequency is divided by 10 to produce the instruction cycle clock ($1/t_c$).

Figure 7 shows the Crystal diagram.

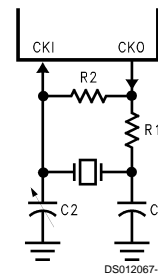

FIGURE 7. Crystal Oscillator Diagram

CRYSTAL OSCILLATOR

CKI and CKO can be connected to make a closed loop crystal (or resonator) controlled oscillator.

Table 1 shows the component values required for various standard crystal values.

Oscillator Circuits (Continued)

TABLE 1. Crystal Oscillator Configuration, $T_A = 25^\circ\text{C}$

R1 (k Ω)	R2 (M Ω)	C1 (pF)	C2 (pF)	CKI Freq. (MHz)	Conditions
0	1	30	30–36	10	$V_{CC} = 5V$
0	1	30	30–36	4	$V_{CC} = 5V$
0	1	200	100–150	0.455	$V_{CC} = 5V$

Control Registers

CNTRL Register (Address X'00EE)

T1C3	T1C2	T1C1	T1C0	MSEL	IEDG	SL1	SL0
Bit 7							Bit 0

The Timer1 (T1) and MICROWIRE/PLUS control register contains the following bits:

T1C3	Timer T1 mode control bit
T1C2	Timer T1 mode control bit
T1C1	Timer T1 mode control bit
T1C0	Timer T1 Start/Stop control in timer modes 1 and 2, T1 Underflow Interrupt Pending Flag in timer mode 3
MSEL	Selects G5 and G4 as MICROWIRE/PLUS signals SK and SO respectively
IEDG	External interrupt edge polarity select (0 = Rising edge, 1 = Falling edge)
SL1 & SL0	Select the MICROWIRE/PLUS clock divide by (00 = 2, 01 = 4, 1x = 8)

PSW Register (Address X'00EF)

HC	C	T1PNDA	T1ENA	EXPND	BUSY	EXEN	GIE
Bit 7							Bit 0

The PSW register contains the following select bits:

HC	Half Carry Flag
C	Carry Flag
T1PNDA	Timer T1 Interrupt Pending Flag (Autoreload RA in mode 1, T1 Underflow in Mode 2, T1A capture edge in mode 3)
T1ENA	Timer T1 Interrupt Enable for Timer Underflow or T1A Input capture edge
EXPND	External interrupt pending
BUSY	MICROWIRE/PLUS busy shifting flag
EXEN	Enable external interrupt
GIE	Global interrupt enable (enables interrupts)

The Half-Carry flag is also affected by all the instructions that affect the Carry flag. The SC (Set Carry) and R/C (Reset Carry) instructions will respectively set or clear both the carry flags. In addition to the SC and R/C instructions, ADC, SUBC, RRC and RLC instructions affect the Carry and Half Carry flags.

ICNTRL Register (Address X'00E8)

Reserved	LPEN	T0PND	T0EN	μ WPND	μ WEN	T1PNDB	T1ENB
Bit 7							Bit 0

The ICNTRL register contains the following bits:

Reserved	This bit is reserved and should be zero.
LPEN	L Port Interrupt Enable (Multi-Input Wakeup/Interrupt)

T0PND	Timer T0 Interrupt pending
T0EN	Timer T0 Interrupt Enable (Bit 12 toggle)
μ WPND	MICROWIRE/PLUS interrupt pending
μ WEN	Enable MICROWIRE/PLUS interrupt
T1PNDB	Timer T1 Interrupt Pending Flag for T1B capture edge
T1ENB	Timer T1 Interrupt Enable for T1B Input capture edge

Timers

The device contains a very versatile set of timers (T0, T1, and an 8-bit PWM timer). All timers and associated autoreload/capture registers power up containing random data.

Figure 8 shows a block diagram for timers T1 and T0 on the device.

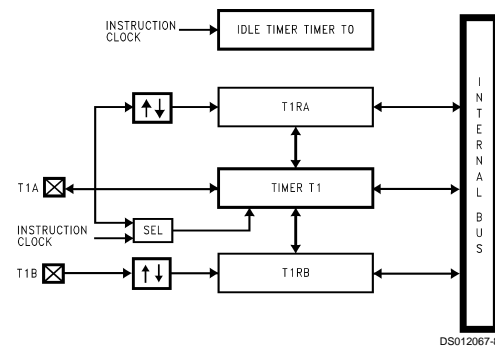

FIGURE 8. Timers T1 and T0

TIMER T0 (IDLE TIMER)

The device supports applications that require maintaining real time and low power with the IDLE mode. This IDLE mode support is furnished by the IDLE timer T0, which is a 16-bit timer. The Timer T0 runs continuously at the fixed rate of the instruction cycle clock, t_c . The user cannot read or write to the IDLE Timer T0, which is a count down timer.

The Timer T0 supports the following functions:

- Exit out of the Idle Mode (See Idle Mode description)
- Start up delay out of the HALT mode

The IDLE Timer T0 can generate an interrupt when the thirteenth bit toggles. This toggle is latched into the T0PND pending flag, and will occur every 4.096 ms at the maximum clock frequency ($t_c = 1 \mu\text{s}$). A control flag T0EN allows the interrupt from the thirteenth bit of Timer T0 to be enabled or disabled. Setting T0EN will enable the interrupt, while resetting it will disable the interrupt.

TIMER T1

The device has a powerful timer/counter block, T1.

The timer block consists of a 16-bit timer, T1, and two supporting 16-bit autoreload/capture registers, R1A and R1B. The timer block has two pins associated with it, T1A and T1B. The pin T1A supports I/O required by the timer block, while the pin T1B is an input to the timer block. The powerful and flexible timer block allows the device to easily perform all timer functions with minimal software overhead. The timer

Timers (Continued)

block has three operating modes: Processor Independent PWM mode, External Event Counter mode, and Input Capture mode.

The control bits T1C3, T1C2, and T1C1 allow selection of the different modes of operation.

Mode 1. Processor Independent PWM Mode

As the name suggests, this mode allows the device to generate a PWM signal with very minimal user intervention.

The user only has to define the parameters of the PWM signal (ON time and OFF time). Once begun, the timer block will continuously generate the PWM signal completely independent of the microcontroller. The user software services the timer block only when the PWM parameters require updating.

In this mode the timer T1 counts down at a fixed rate of t_c . Upon every underflow the timer is alternately reloaded with the contents of supporting registers, R1A and R1B. The very first underflow of the timer causes the timer to reload from the register R1A. Subsequent underflows cause the timer to be reloaded from the registers alternately beginning with the register R1B.

The T1 Timer control bits, T1C3, T1C2 and T1C1 set up the timer for PWM mode operation.

Figure 9 shows a block diagram of the timer in PWM mode. The underflows can be programmed to toggle the T1A output pin. The underflows can also be programmed to generate interrupts.

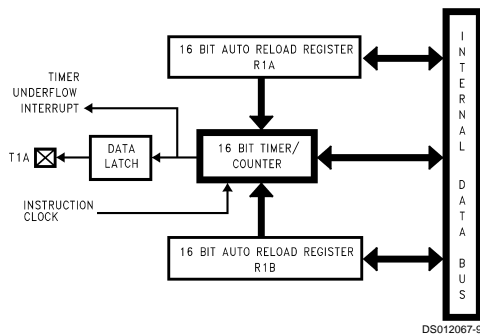

FIGURE 9. Timer 1 in PWM MODE

Underflows from the timer are alternately latched into two pending flags, T1PNDA and T1PNDB. The user must reset these pending flags under software control. Two control enable flags, T1ENA and T1ENB, allow the interrupts from the timer underflow to be enabled or disabled. Setting the timer enable flag T1ENA will cause an interrupt when a timer underflow causes the R1A register to be reloaded into the timer. Setting the timer enable flag T1ENB will cause an interrupt when a timer underflow causes the R1B register to be reloaded into the timer. Resetting the timer enable flags will disable the associated interrupts.

Either or both of the timer underflow interrupts may be enabled. This gives the user the flexibility of interrupting once per PWM period on either the rising or falling edge of the PWM output. Alternatively, the user may choose to interrupt on both edges of the PWM output.

Mode 2. External Event Counter Mode

This mode is quite similar to the processor independent PWM mode described above. The main difference is that the timer, T1, is clocked by the input signal from the T1A pin. The T1 timer control bits, T1C3, T1C2 and T1C1 allow the timer to be clocked either on a positive or negative edge from the T1A pin. Underflows from the timer are latched into the T1PNDA pending flag. Setting the T1ENA control flag will cause an interrupt when the timer underflows.

In this mode the input pin T1B can be used as an independent positive edge sensitive interrupt input if the T1ENB control flag is set. The occurrence of a positive edge on the T1B input pin is latched into the T1PNDB flag.

Figure 10 shows a block diagram of the timer in External Event Counter mode.

Note: The PWM output is not available in this mode since the T1A pin is being used as the counter input clock.

Mode 3. Input Capture Mode

The device can precisely measure external frequencies or time external events by placing the timer block, T1, in the input capture mode.

In this mode, the timer T1 is constantly running at the fixed t_c rate. The two registers, R1A and R1B, act as capture registers. Each register acts in conjunction with a pin. The register R1A acts in conjunction with the T1A pin and the register R1B acts in conjunction with the T1B pin.

The timer value gets copied over into the register when a trigger event occurs on its corresponding pin. Control bits, T1C3, T1C2 and T1C1, allow the trigger events to be specified either as a positive or a negative edge. The trigger condition for each input pin can be specified independently.

The trigger conditions can also be programmed to generate interrupts. The occurrence of the specified trigger condition on the T1A and T1B pins will be respectively latched into the pending flags, T1PNDA and T1PNDB. The control flag T1ENA allows the interrupt on T1A to be either enabled or disabled. Setting the T1ENA flag enables interrupts to be generated when the selected trigger condition occurs on the T1A pin. Similarly, the flag T1ENB controls the interrupts from the T1B pin.

Underflows from the timer can also be programmed to generate interrupts. Underflows are latched into the timer T1C0 pending flag (the T1C0 control bit serves as the timer underflow interrupt pending flag in the Input Capture mode). Consequently, the T1C0 control bit should be reset when entering the Input Capture mode. The timer underflow interrupt is enabled with the T1ENA control flag. When a T1A interrupt occurs in the Input Capture mode, the user must check both the T1PNDA and T1C0 pending flags in order to determine whether a T1A input capture or a timer underflow (or both) caused the interrupt.

Figure 11 shows a block diagram of the timer in Input Capture mode.

Timers (Continued)

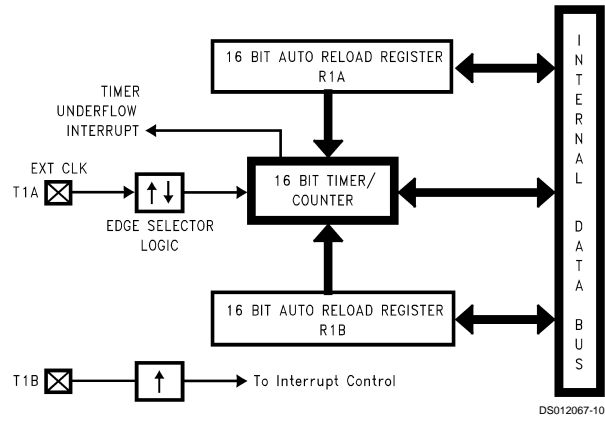

FIGURE 10. Timer 1 in External Event Counter Mode

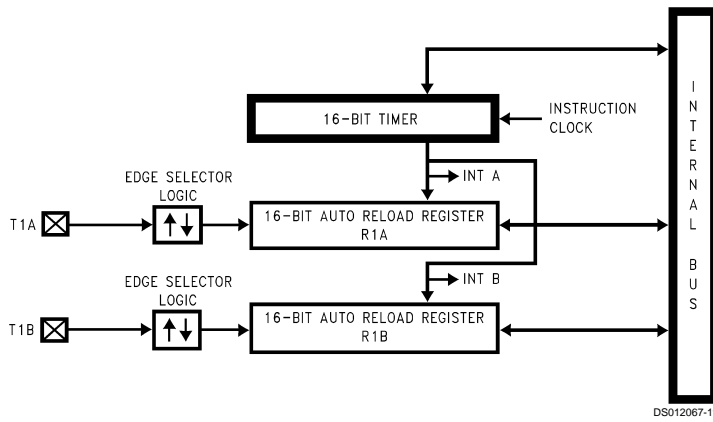

FIGURE 11. Timer 1 in Input Capture Mode

Timers (Continued)

TIMER CONTROL FLAGS

The control bits and their functions are summarized below.

T1C3	Timer mode control
T1C2	Timer mode control
T1C1	Timer mode control
T1C0	Timer Start/Stop control in Modes 1 and 2 (Processor Independent PWM and External Event Counter), where 1 = Start, 0 = Stop
	Timer Underflow Interrupt Pending Flag in Mode 3 (Input Capture)

T1PNDA	Timer Interrupt Pending Flag
T1ENA	Timer Interrupt Enable Flag
	1 = Timer Interrupt Enabled
	0 = Timer Interrupt Disabled
T1PNDB	Timer Interrupt Pending Flag
T1ENB	Timer Interrupt Enable Flag
	1 = Timer Interrupt Enabled
	0 = Timer Interrupt Disabled

The timer mode control bits (T1C3, T1C2 and T1C1) are detailed below:

Mode	T1C3	T1C2	T1C1	Description	Interrupt A Source	Interrupt B Source	Timer Counts On
1	1	0	1	PWM: T1A Toggle	Autoreload RA	Autoreload RB	t_c
	1	0	0	PWM: No T1A Toggle	Autoreload RA	Autoreload RB	t_c
2	0	0	0	External Event Counter	Timer Underflow	Pos. T1B Edge	Pos. T1A Edge
	0	0	1	External Event Counter	Timer Underflow	Pos. T1B Edge	Pos. T1A Edge
3	0	1	0	Captures: T1A Pos. Edge T1B Pos. Edge	Pos. T1A Edge or Timer Underflow	Pos. T1B Edge	t_c
	1	1	0	Captures: T1A Pos. Edge T1B Neg. Edge	Pos. T1A Edge or Timer Underflow	Neg. T1B Edge	t_c
	0	1	1	Captures: T1A Neg. Edge T1B Neg. Edge	Neg. T1A Edge or Timer Underflow	Neg. T1B Edge	t_c
	1	1	1	Captures: T1A Neg. Edge T1B Neg. Edge	Neg. T1A Edge or Timer Underflow	Neg. T1B Edge	t_c

HIGH SPEED, CONSTANT RESOLUTION PWM TIMER

The device has one processor independent PWM timer. The PWM timer operates in two modes: PWM mode and capture mode. In PWM mode the timer outputs can be programmed to two pins PWM0 and PWM1. In capture mode, pin PWM0 functions as the capture input. *Figure 12* shows a block diagram for this timer in capture mode and *Figure 13* shows a block diagram for the timer in PWM mode.

PWM Timer Registers

The PWM Timer has three registers: PWMCON, the PWM control register, RLON, the PWM on-time register and PSCAL, the prescaler register.

PWM Prescaler Register (PSCAL) (Address X'00A0)

The prescaler is the clock source for the counter in both PWM mode and in frequency monitor mode.

PSCAL is a read/write register that can be used to program the prescaler. The clock source to the timer in both PWM and capture modes can be programmed to CKI/N where N =

PSCAL + 1, so the maximum PWM clock frequency = CKI and the minimum PWM clock frequency = CKI/256. The processor is able to modify the PSCAL register regardless of whether the counter is running or not and the change in frequency occurs with the next underflow of the prescaler (CK-PWM).

PWM On-time Register (RLON) (Address X'00A1)

RLON is a read/write register. In PWM mode the timer output will be a "1" for RLON counts out of a total cycle of 255 PWM clocks. In capture mode it is used to program the threshold frequency.

The PWM timer is specially designed to have a resolution of 255 PWM clocks. This allows the duty cycle of the PWM output to be selected between 1/255 and 254/255. A value of 0 in the RLON register will result in the PWM output being continuously low and a value of 255 will result in the PWM output being continuously high.

Note: The effect of changing the RLON register during active PWM mode operation is delayed until the boundary of a PWM cycle. In capture mode the effect takes place immediately.

Timers (Continued)

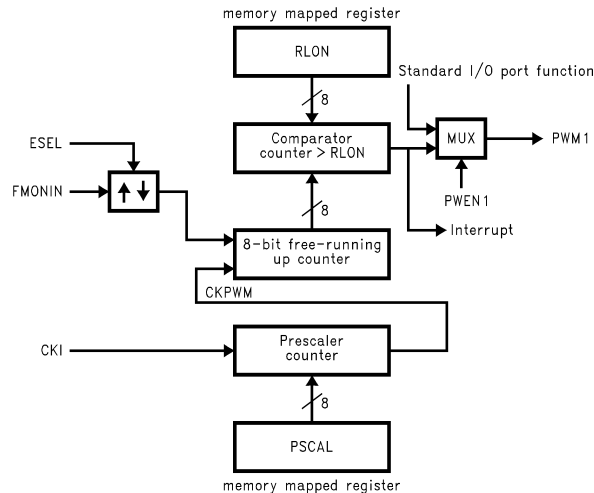

DS012067-12

FIGURE 12. PWM Timer Capture Mode Block Diagram

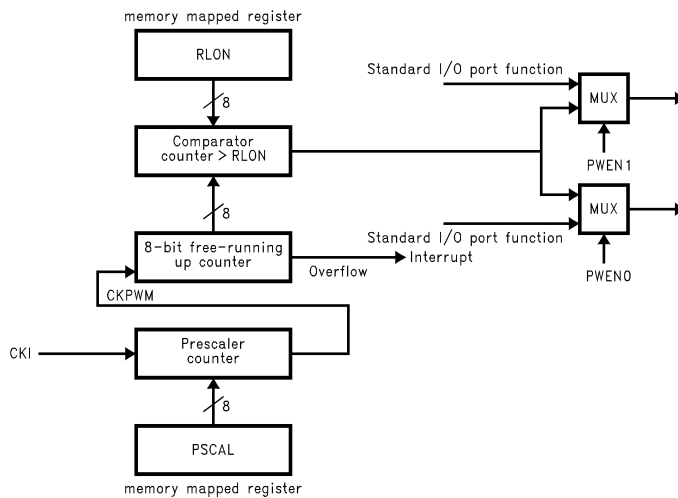

DS012067-13

FIGURE 13. PWM Timer PWM Mode Block Diagram

PWM Control Register (PWMCON) (Address X'00A2)

Reserved	ESEL	PWPND	PWIE	PWMD	PWON	PWEN1	PWEN0
Bit 7							Bit 0

The PWMCON Register Bits are:

- Reserved** This bit is reserved and must be zero.
- ESEL** Edge select bit, "1" for falling edge, "0" for rising edge.
- PWPND** PWM interrupt pending bit.
- PWIE** PWM interrupt enable bit.
- PWMD** PWM Mode bit, "1" for PWM mode, "0" for frequency monitor mode.
- PWON** PWM start Bit, "1" to start timer, "0" to stop timer.

PWEN1 Enable PWM1 output function on I/O port.

Note: The associated bits in the configuration and data register of the I/O port have to be setup as outputs and/or inputs in addition to setting the PWEN bits.

PWEN0 Enable PWM0 output/input function on I/O port.

PWM Mode

The PWM timer can generate PWM signals at frequencies up to 39 kHz (@ $t_c = 1 \mu s$) with a resolution of 255 parts. Lower PWM frequencies can be programmed via the prescaler.

If the PWM mode bit (PWMD) in the PWM configuration register (PWMCON) is set to "1" the timer operates in PWM mode. In this mode, the timer generates a PWM signal with

Timers (Continued)

a fixed, non-programmable repetition rate of 255 PWM clock cycles. The timer is clocked by the output of an 8-bit, programmable prescaler, which is clocked with the chip's CKI frequency. Thus the PWM signal frequency can be calculated with the formula:

$$f_{\text{pwm}} = \frac{\text{CKI}}{(1 + (\text{PSCAL-contents})) \times 255}$$

Selecting the PWM mode by setting PWMD to "1", but not yet starting the timer (PWON is "0"), will set the timer output to "1".

The contents of an 8-bit register, ROLON, multiplied by the clock cycle of the prescaler output defines the time between overflow (or starting) and the falling edge of the PWM output. Once the timer is started, the timer output goes low after ROLON cycles and high after a total of 255 cycles. The procedure is continually repeated. In PWM mode the timer is available at pins PWM0 and/or PWM1, provided the port configuration bits for those pins are defined as outputs and the PWEN0 and/or PWEN1 bits in the PWMCON register are set.

The PWM timer is started by the software setting the PWON bit to "1". Starting the timer initializes the timer register. From this point, the timer will continually generate the PWM signal, independent of any processor activity, until the timer is stopped by software setting the PWON bit to "0". The processor is able to modify the ROLON register regardless of whether the timer is running. If ROLON is changed while the timer is running, the previous value of ROLON is used for comparison until the next overflow occurs, when the new value of ROLON is latched into the comparator inputs.

When the timer overflows, the PWM pending flag (PWPND) is set to "1". If the PWM interrupt enable bit (PWIE) is also set to "1", timer overflow will generate an interrupt. The PWPND bit remains set until the user's software writes a "0" to it. If the software writes a "1" to the PWPND bit, this has no effect. If the software writes a "0" to the PWPND bit at the same time as the hardware writes to the bit, the hardware has precedence.

Note: The software controlling the duty cycle is able to change the PWM duty cycle without having to wait for the timer overflow.

Figure 14 shows how the PWM output is implemented. The PWM Timer output is set to "1" on an overflow of the timer and set to "0" when the timer is greater than ROLON. The output can be multiplexed to two pins.

Capture Mode

If PWMD bit (PWMD) is set to "0" the PWM Timer operates in capture mode. Capture mode allows the programmer to test whether the frequency of an external source exceeds a certain threshold.

If PWMD is "0" and PWON is "0", the timer output is set to "0". In capture mode the timer output is available at pin PWM1, provided the port configuration register bit for that pin is set up as an output and the PWEN1 bit in the PWMCON register is set. Setting PWON to "1" will initialize the timer register and start the counter. A rising edge, or if selected, a falling edge, on the FMONIN input pin will initialize the timer register and clear the timer output. The counter continues to count up after being initialized. The ESEL bit determines whether the active edge is a rising or a falling edge.

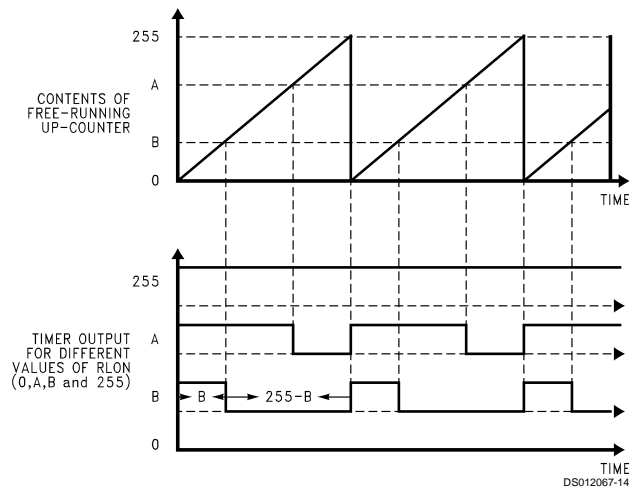

FIGURE 14. PWM Mode Operation

If, in capture mode PWM0 is configured incorrectly as an output and is enabled via the PWEN0 bit, the timer output will feedback into the PWM block as the timer input.

The contents of the counter are continually compared with the ROLON register. If the frequency of the input edges is sufficiently high, the contents of the counter will always be less

than the value in ROLON. However, if the frequency of the input edges is too low, the free-running counter value will count up beyond the value in ROLON.

When the counter is greater than ROLON, the PWM timer output is set to "1". It is set to "0" by a detected edge on the timer input or when the counter overflows. When the counter be-

Timers (Continued)

comes greater than R_{LON}, the PWPND bit in the PWM control register is set to "1". If the PWIE bit is also set to "1", the PWPND bit is enabled to request an interrupt.

It should be noted that two other conditions could also set the PWPND bit:

1. If the mode of operation is changed on the fly the timer output will toggle. If frequency monitor mode is entered on the fly such that the timer output changes from 0 to 1, PWPND will be set.
2. If the timer is operating in frequency monitor mode and the R_{LON} value is changed on the fly so that R_{LON} be-

comes less than the current timer value, PWPND will be set.

The PWPND bit remains set until the user's software writes a "0" to it. If the software writes a "1" to the PWPND bit, this has no effect. If the software writes a "0" to the PWPND bit at the same time as the hardware writes to the bit, the hardware has precedence. (See Figure 17 for Frequency Monitor Mode Operation.)

Note: If the clock to the device stops while PWM0 is high, and a subsequent Reset occurs while the clock is stopped, the PWM0/L6 output will be put in the weak pull-up mode until the clock resumes.

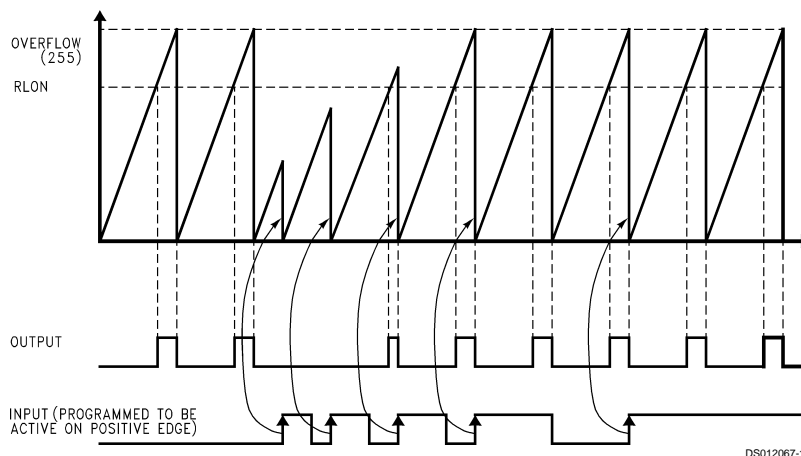

FIGURE 15. Frequency Monitor Mode Operation

Power Save Modes

The device offers the user two power save modes of operation: HALT and IDLE. In the HALT mode, all microcontroller activities are stopped. In the IDLE mode, the on-board oscillator circuitry and timer T₀ are active but all other microcontroller activities are stopped. In either mode, all on-board RAM, registers, I/O states, and timers (with the exception of T₀) are unaltered.

HALT MODE

The contents of all PWM Timer registers are frozen during HALT mode and are left unchanged when exiting HALT mode. The PWM timer resumes its previous mode of operation when exiting HALT mode.

The device is placed in the HALT mode by writing a "1" to the HALT flag (G7 data bit). All microcontroller activities, including the clock, and timers, are stopped. In the HALT mode, the power requirements of the device are minimal and the applied voltage (V_{CC}) may be decreased to V_r ($V_r = 2.0V$) without altering the state of the machine.

The device supports two different ways of exiting the HALT mode. The first method of exiting the HALT mode is with the Multi-Input Wake Up feature on the L port. The second method of exiting the HALT mode is by pulling the RESET pin low.

Since a crystal or ceramic resonator may be selected as the oscillator, the Wake Up signal is not allowed to start the chip

running immediately since crystal oscillators and ceramic resonators have a delayed start up time to reach full amplitude and frequency stability. The IDLE timer is used to generate a fixed delay to ensure that the oscillator has indeed stabilized before allowing instruction execution. In this case, upon detecting a valid Wake Up signal, only the oscillator circuitry is enabled. The IDLE timer is loaded with a value of 256 and is clocked with the t_c instruction cycle clock. The t_c clock is derived by dividing the oscillator clock down by a factor of 10. The Schmitt trigger following the CKI inverter on the chip ensures that the IDLE timer is clocked only when the oscillator has a sufficiently large amplitude to meet the Schmitt trigger specifications. This Schmitt trigger is not part of the oscillator closed loop. The start-up time-out from the IDLE timer enables the clock signals to be routed to the rest of the chip.

The device has two mask options associated with the HALT mode. The first mask option enables the HALT mode feature, while the second mask option disables the HALT mode. With the HALT mode enable mask option, the device will enter and exit the HALT mode as described above. With the HALT disable mask option, the device cannot be placed in the HALT mode (writing a "1" to the HALT flag will have no effect).

IDLE MODE

The device is placed in the IDLE mode by writing a "1" to the IDLE flag (G6 data bit). In this mode, all activities, except the associated on-board oscillator circuitry, and the IDLE Timer

Power Save Modes (Continued)

T0, are stopped. The power supply requirements of the microcontroller in this mode of operation are typically around 30% of normal power requirement of the microcontroller.

As with the HALT mode, the device can be returned to normal operation with a reset, or with a Multi-Input Wake Up from the L Port or CAN Interface. Alternately, the microcontroller resumes normal operation from the IDLE mode when the thirteenth bit (representing 4.096 ms at internal clock frequency of 1 MHz, $t_c = 1 \mu s$) of the IDLE Timer toggles.

This toggle condition of the thirteenth bit of the IDLE Timer T0 is latched into the TOPND pending flag.

The user has the option of being interrupted with a transition on the thirteenth bit of the IDLE Timer T0. The interrupt can be enabled or disabled via the T0EN control bit. Setting the T0EN flag enables the interrupt and vice versa.

The user can enter the IDLE mode with the Timer T0 interrupt enabled. In this case, when the TOPND bit gets set, the device will first execute the Timer T0 interrupt service routine and then return to the instruction following the "Enter Idle Mode" instruction.

Alternatively, the user can enter the IDLE mode with the IDLE Timer T0 interrupt disabled. In this case, the device will resume normal operation with the instruction immediately following the "Enter IDLE Mode" instruction.

Note: It is necessary to program two NOP instructions following both the set HALT mode and set IDLE mode instructions. These NOP instructions are necessary to allow clock resynchronization following the HALT or IDLE modes.

Multi-Input Wake Up

The Multi-Input Wake Up feature is used to return (wake up) the device from either the HALT or IDLE modes. Alternately, the Multi-Input Wake Up/Interrupt feature may also be used to generate up to 7 edge selectable external interrupts.

Figure 18 shows the Multi-Input Wake Up logic for the microcontroller. The Multi-Input Wake Up feature utilizes the L Port. The user selects which particular L port bit (or combination of L Port bits) will cause the device to exit the HALT or IDLE modes. The selection is done through the Reg: WKEN. The Reg: WKEN is an 8-bit read/write register, which contains a control bit for every L port bit. Setting a particular WKEN bit enables a Wake Up from the associated port pin.

The user can select whether the trigger condition on the selected L Port pin is going to be either a positive edge (low to

high transition) or a negative edge (high to low transition). This selection is made via the Reg: WKEDG, which is an 8-bit control register with a bit assigned to each L Port pin. Setting the control bit will select the trigger condition to be a negative edge on that particular L Port pin. Resetting the bit selects the trigger condition to be a positive edge. Changing an edge select entails several steps in order to avoid a pseudo Wake Up condition as a result of the edge change. First, the associated WKEN bit should be reset, followed by the edge select change in WKEDG. Next, the associated WKPND bit should be cleared, followed by the associated WKEN bit being re-enabled.

An example may serve to clarify this procedure. Suppose we wish to change the edge select from positive (low going high) to negative (high going low) for L Port bit 5, where bit 5 has previously been enabled for an input interrupt. The program would be as follows:

```
RBIT 5, WKEN ; Disable MIWU
SBIT 5, WKEDG ; Change edge polarity
RBIT 5, WKPND ; Reset pending flag
SBIT 5, WKEN ; Enable MIWU
```

If the L port bits have been used as outputs and then changed to inputs with Multi-Input Wake Up/Interrupt, a safety procedure should also be followed to avoid inherited pseudo wake up conditions. After the selected L port bits have been changed from output to input but before the associated WKEN bits are enabled, the associated edge select bits in WKEDG should be set or reset for the desired edge selects, followed by the associated WKPND bits being cleared.

This same procedure should be used following reset, since the L port inputs are left floating as a result of reset. The occurrence of the selected trigger condition for Multi-Input Wake Up is latched into a pending register called WKPND. The respective bits of the WKPND register will be set on the occurrence of the selected trigger edge on the corresponding Port L pin. The user has the responsibility of clearing these pending flags. Since WKPND is a pending register for the occurrence of selected wake up conditions, the device will not enter the HALT mode if any Wake Up bit is both enabled and pending. Consequently, the user has the responsibility of clearing the pending flags before attempting to enter the HALT mode.

The WKEN, WKPND and WKEDG are all read/write registers, and are cleared at reset.

Multi-Input Wake Up (Continued)

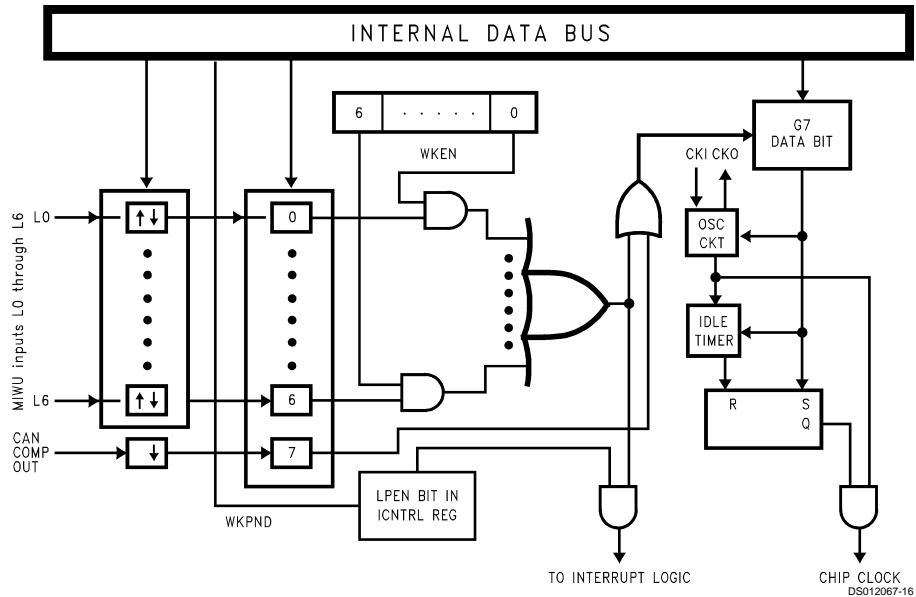

FIGURE 16. Multi-Input Wake Up Logic

CAN RECEIVE WAKE UP

The CAN Receive Wake Up source is always enabled and is always active on a falling edge of the CAN comparator output. There is no specific enable bit for the CAN Wake Up feature. Although the wake up feature on pins L0..L6 can be programmed to generate an interrupt (L-port interrupt), no interrupt is generated upon a CAN receive wake up condition. The CAN block has its own, dedicated receiver interrupt upon receive buffer full.

PORT L INTERRUPTS

Port L provides the user with an additional seven fully selectable, edge sensitive interrupts which are all vectored into the same service subroutine.

The interrupt from Port L shares logic with the wake up circuitry. The register WKEN allows interrupts from Port L to be individually enabled or disabled. The register WKEDG specifies the trigger condition to be either a positive or a negative edge. Finally, the register WKPND latches in the pending trigger conditions.

The GIE (global interrupt enable) bit enables the interrupt function. A control flag, LPEN, functions as a global interrupt enable for Port L interrupts. Setting the LPEN flag will enable interrupts and vice versa. A separate global pending flag is not needed since the register WKPND is adequate.

Since Port L is also used for waking the device out of the HALT or IDLE modes, the user can elect to exit the HALT or IDLE modes either with or without the interrupt enabled. If he elects to disable the interrupt, then the device will restart execution from the instruction immediately following the instruction that placed the microcontroller in the HALT or IDLE modes. In the other case, the device will first execute the interrupt service routine and then revert to normal operation.

The Wake Up signal will not start the chip running immediately since crystal oscillators or ceramic resonators have a fi-

nite start up time. The IDLE Timer (T0) generates a fixed delay to ensure that the oscillator has indeed stabilized before allowing the device to execute instructions. In this case, upon detecting a valid Wake Up signal, only the oscillator circuitry and the IDLE Timer T0 are enabled. The IDLE Timer is loaded with a value of 256 and is clocked from the t_c instruction cycle clock. The t_c clock is derived by dividing down the oscillator clock by a factor of 10. A Schmitt trigger following the CKI on-chip inverter ensures that the IDLE timer is clocked only when the oscillator has a sufficiently large amplitude to meet the Schmitt trigger specifications. This Schmitt trigger is not part of the oscillator closed loop. The start-up time-out from the IDLE timer enables the clock signals to be routed to the rest of the chip.

CAN Block Description *

This device contains a CAN serial bus interface as described in the CAN Specification Rev. 2.0 part B.

*Patents Pending.

CAN Interface Block

This device supports applications which require a low speed CAN interface. It is designed to be programmed with two transmit and two receive registers. The user's program may check the status bytes in order to get information of the bus state and the received or transmitted messages. The device has the capability to generate an interrupt as soon as one byte has been transmitted or received. Care must be taken if more than two bytes in a message frame are to be transmitted/received. In this case the user's program must poll the transmit buffer empty (TBE)/receive buffer full (RBF) bits or enable their respective interrupts and perform a data exchange between the user data and the Tx/Rx registers.

CAN Interface Block (Continued)

Fully automatic transmission on error is supported for messages not longer than two bytes. Messages which are longer than two bytes have to be processed by software.

The interface is compatible with CAN Specification 2.0 part B, without the capability to receive/transmit extended frames. Extended frames on the bus are checked and acknowledged according to the CAN specification.

The maximum bus speed achievable with the CAN interface is a function of crystal frequency, message length and soft-

ware overhead. The device can support a bus speed of up to 1 Mbit/s with a 10 MHz oscillator and 2 byte messages. The 1 Mbit/s bus speed refers to the rate at which protocol and data bits are transferred on the bus. Longer messages require slower bus speeds due to the time required for software intervention between data bytes. The device will support a maximum of 125k bit/s with eight byte messages and a 10 MHz oscillator.

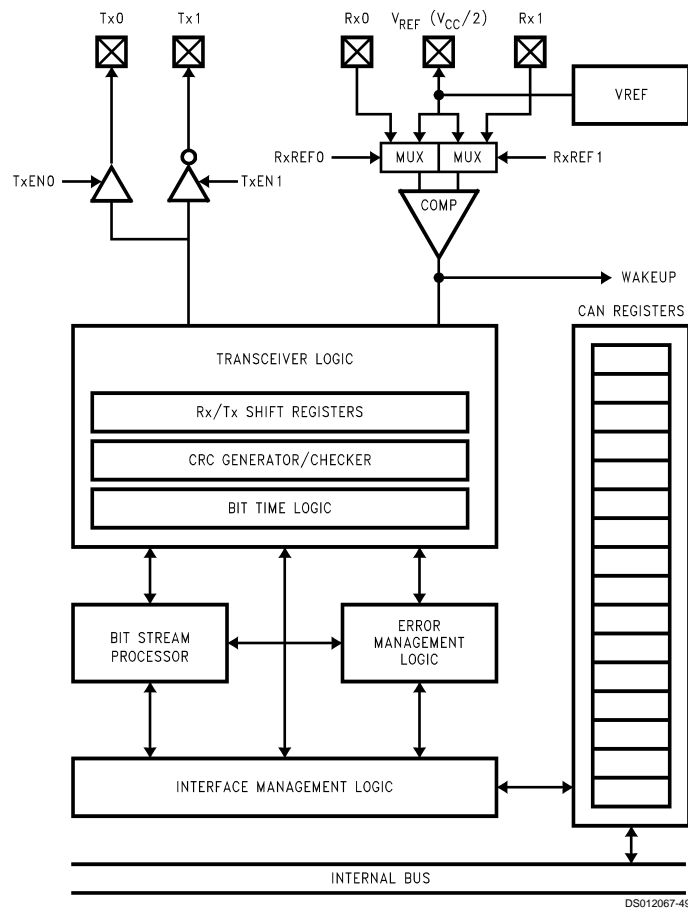

FIGURE 17. CAN Interface Block Diagram

Functional Block Description of the CAN Interface

Interface Management Logic (IML)

The IML executes the CPU's transmission and reception commands and controls the data transfer between CPU, Rx/Tx and CAN registers. It provides the CAN Interface with Rx/Tx data from the memory mapped Register Block. It also sets and resets the CAN status information and generates interrupts to the CPU.

Bit Stream Processor (BSP)

The BSP is a sequencer controlling the data stream between The Interface Management Logic (parallel data) and the bus line (serial data). It controls the transceiver logic with regard to reception and arbitration, and creates error signals according to the bus specification.

Functional Block Description of the CAN Interface (Continued)

Transceiver Logic (TCL)

The TCL is a state machine which incorporates the bit stuff logic and controls the output drivers, CRC logic and the Rx/Tx shift registers. It also controls the synchronization to the bus with the CAN clock signal generated by the BTL.

Error Management Logic (EML)

The EML is responsible for the fault confinement of the CAN protocol. It is also responsible for changing the error counters, setting the appropriate error flag bits and interrupts and changing the error status (passive, active and bus off).

Cyclic Redundancy Check (CRC) Generator and Register

The CRC Generator consists of a 15-bit shift register and the logic required to generate the checksum of the destuffed bitstream. It informs the EML about the result of a receiver checksum.

The checksum is generated by the polynomial:

$$\chi^{15} + \chi^{14} + \chi^{10} + \chi^8 + \chi^7 + \chi^4 + \chi^3 + 1$$

Receive/Transmit (Rx/Tx) Registers

The Rx/Tx registers are 8-bit shift registers controlled by the TCL and the BSP. They are loaded or read by the Interface Management Logic, which holds the data to be transmitted or the data that was received.

Bit Time Logic (BTL)

The bit time logic divider divides the CKI input clock by the value defined in the CAN prescaler (CSCAL) and bus timing register (CTIM). The resulting bit time (t_{can}) can be computed by the formula:

$$t_{can} = \frac{CKI}{(1 + divider) \times (1 + 2 \times PS + PPS)}$$

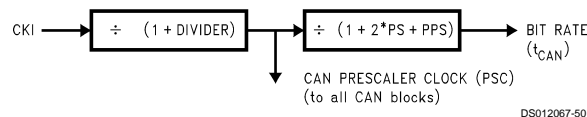

FIGURE 18. Bit Rate Generation

Figure 19 illustrates the minimum time required for t_{LOAD} .

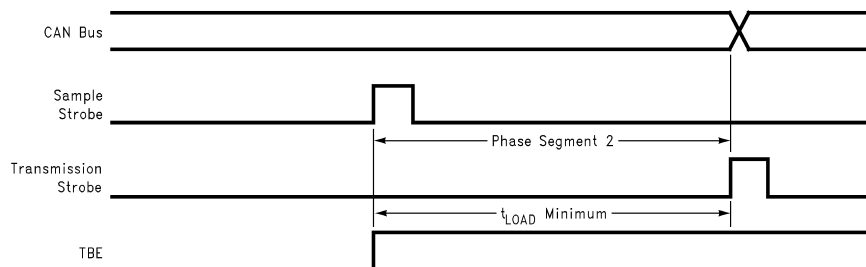

FIGURE 19. TBE Timing

Where *divider* is the value of the clock prescaler, *PS* is the programmable value of phase segment 1 and 2 (1..8) and *PPS* the programmed value of the propagation segment (1..8) (located in CTIM).

Bus Timing Considerations

The internal architecture of the CAN interface has been optimized to allow fast software response times within messages of more than two data bytes. The TBE (Transmit Buffer Empty) bit is set on the last bit of odd data bytes when CAN internal sample points are high.

It is the user's responsibility to ensure that the time between setting TBE and a reload of TxD2 is longer than the length of phase segment 2 as indicated in the following equation:

$$t_{LOAD} > \frac{(PS + 1) \times (CSCAL + 1)}{10} t_C = \text{absolute length of PS2}$$

Table 2 shows examples of the minimum required t_{LOAD} for different CSCAL settings based on a clock frequency of 10 MHz. Lower clock speeds require recalculation of the CAN bit rate and the minimum t_{LOAD} .

TABLE 2. CAN Timing (CKI = 10 MHz $t_c = 1 \mu s$)

PS	CSCAL	CAN Bit Rate (kbit/s)	Minimum t_{LOAD} (μs)
4	3	250	2.0
4	9	100	5.0
4	15	62	8.0
4	24	40	12.5
4	39	25	20
4	99	10	50
4	199	5	100

Functional Block Description of the CAN Interface (Continued)

In the case of an interrupt driven CAN interface, the calculation of the actual t_{LOAD} time would be done as follows:

```

INT:                                     ; Interrupt latency = 7 tc = 7 µs
    PUSH A                               ; 3 tc = 3 µs
    LD  A,AB                             ; 2 tc = 2 µs
    PUSH A                               ; 3 tc = 3 µs
    VIS                                  ; 5 tc = 5 µs
CANTX:                                  ; 20 tc = µs to this point
    .                                     ; additional time for instructions which check
    .                                     ; status prior to reloading the transmit data
    .                                     ; registers with subsequent data bytes.
    LD  TXD2,DATA
    .
    .
    .
    
```

Interrupt driven programs use more time than programs which poll the TBE flag, however programs which operate at lower baud rates (which are more likely to be sensitive to this issue) have more time for interrupt response.

Output Drivers/Input Comparators

The output drivers/input comparators are the physical interface to the bus. Control bits are provided to TRI-STATE the output drivers.

A dominant bit on the bus is represented as a "0" in the data registers and a recessive bit on the bus is represented as a "1" in the data registers.

TABLE 3. Bus Level Definition

Bus Level	Pin Tx0	Pin Tx1	Data
"dominant"	drive low (GND)	drive high (V_{CC})	0
"recessive"	TRI-STATE	TRI-STATE	1

Register Block

The register block consists of fifteen 8-bit registers which are described in more detail in the following paragraphs.

Note: The contents of the receiver related registers RxD1, RxD2, RDLC, RIDH and RTSTAT are only changed if a received frame passes the acceptance filter or the Receive Identifier Acceptance Filter bit (RIAF) is set to accept all received messages.

TRANSMIT DATA REGISTER 1 (TXD1) (Address X'00B0)

The Transmit Data Register 1 contains the first data byte to be transmitted within a frame and then the successive odd byte numbers (i.e., bytes number 1,3,..,7).

TRANSMIT DATA REGISTER 2 (TXD2)(Address X'00B1)

The Transit Data Register 2 contains the second data byte to be transmitted within a frame and then the successive even byte numbers (i.e., bytes number 2,4,..,8).

TRANSMIT DATA LENGTH CODE AND IDENTIFIER LOW REGISTER (TDLC) (Address X'00B2)

TID3	TID2	TID1	TID0	TDLC3	TDLC2	TDLC1	TDLC0
Bit 7							Bit 0

This register is read/write.

TID3..TID0 Transmit Identifier Bits 3..0 (lower 4 bits)

The transmit identifier is composed of eleven bits in total, bits 3 to 0 of the TID are stored in bits 7 to 4 of this register.

TDLC3..TDLC0 Transmit Data Length Code

These bits determine the number of data bytes to be transmitted within a frame. The CAN specification allows a maximum of eight data bytes in any message.

TRANSMIT IDENTIFIER HIGH (TID) (Address X'00B3)

TRTR	TID10	TID9	TID8	TID7	TID6	TID5	TID4
Bit 7							Bit 0

This register is read/write.

TRTR Transmit Remote Frame Request

This bit is set if the frame to be transmitted is a remote frame request.

TID10..TID4 Transmit Identifier Bits 10 .. 4 (higher 7 bits)
Bits TID10..TID4 are the upper 7 bits of the 11 bit transmit identifier.

RECEIVER DATA REGISTER 1 (RXD1) (Address X'00B4)

The Receive Data Register 1 (RXD1) contains the first data byte received in a frame and then successive odd byte numbers (i.e., bytes 1, 3,..,7). This register is read-only.

RECEIVE DATA REGISTER 2 (RXD2) (Address X'00B5)

The Receive Data Register 2 (RXD2) contains the second data byte received in a frame and then successive even byte numbers (i.e., bytes 2,4,..,8). This register is read-only.

REGISTER DATA LENGTH CODE AND IDENTIFIERLOW REGISTER (RIDL) (Address X'00B6)

RID3	RID2	RID1	RID0	RDLC3	RDLC2	RDLC1	RDLC0
Bit 7							Bit 0

This register is read only.

RID3..RID0 Receive Identifier bits (lower four bits)

The RID3..RID0 bits are the lower four bits of the eleven bit long Receive Identifier. Any received message that matches the upper 7 bits of the Receive Identifier (RID10..RID4) is accepted if the Receive Identifier Acceptance Filter (RIAF) bit is set to zero.

RDLC3..RDLC0 Receive Data Length Code bits

The RDLC3..RDLC0 bits determine the number of data bytes within a received frame.

Functional Block Description of the CAN Interface (Continued)

RECEIVE IDENTIFIER HIGH (RID) (Address X'00B7)

Reserved	RID10	RID9	RID8	RID7	RID6	RID5	RID4
Bit 7							Bit 0

This register is read/write.

Reserved Bit 7 is reserved and must be zero.

RID10..RID4 Receive Identifier bits (upper bits)

The RID10..RID4 bits are the upper 7 bits of the eleven bit long Receive Identifier. If the Receive Identifier Acceptance Filter (RIAF) bit (see CBUS register) is set to zero, bits 4 to 10 of the received identifier are compared with the mask bits of RID4..RID10. If the corresponding bits match, the message is accepted. If the RIAF bit is set to a one, the filter function is disabled and all messages, independent of identifier, will be accepted.

CAN PRESCALER REGISTER (CSCAL) (Address X'00B8)

CKS7	CKS6	CKS5	CKS4	CKS3	CKS2	CKS1	CKS0
Bit 7							Bit 0

This register is read/write.

CKS7..0 Prescaler divider select.

The resulting clock value is the CAN Prescaler clock.

CAN BUS TIMING REGISTER (CTIM) (00B9)

PPS2	PPS1	PPS0	PS2	PS1	PS0	Reserved	Reserved
Bit 7							Bit 0

This register is read/write.

PPS2..PPS0 Propagation Segment, bits 2..0

The PPS2..PPS0 bits determine the length of the propagation delay in Prescaler clock cycles (PSC) per bit time. (For a more detailed discussion of propagation delay and phase segments, see SYNCHRONIZATION.)

PS2..PS0 Phase Segment 1, bits 2..0

The PS2..PS0 bits fix the number of Prescaler clock cycles per bit time for phase segment 1 and phase segment 2. The PS2..PS0 bits also set the synchronization Jump Width to a value equal to the lesser of: 4 PSC, or the length of PS1/2 (Min: 4 I length of PS1/2).

TABLE 4. Synchronization Jump Width

PS2	PS1	PS0	Length of Phase Segment 1/2	Synchronization Jump Width
0	0	0	1 t_{can}	1 t_{can}
0	0	1	2 t_{can}	2 t_{can}
0	1	0	3 t_{can}	3 t_{can}
0	1	1	4 t_{can}	4 t_{can}
1	0	0	5 t_{can}	4 t_{can}
1	0	1	6 t_{can}	4 t_{can}
1	1	0	7 t_{can}	4 t_{can}
1	1	1	8 t_{can}	4 t_{can}

LENGTH OF TIME SEGMENTS (See Figure 31)

- The Synchronization Segment is 1 CAN Prescaler clock (PSC)

- The Propagation Segment can be programmed (PPS) to be 1,2,...,8 PSC in length.
- Phase Segment 1 and Phase Segment 2 are programmable (PS) to be 1,2,...,8 PSC long.

Note: (BTL settings at high speed; PSC = 0) Due to the on-chip delay from the rx-pins through the receive comparator (worst case assumption: 3 clocks delay * 2 (devices on the bus) + 1 tx delay) the user needs to set the sample point to (2*3 + 1) i.e., 7 CKI clocks to ensure correct communication on the bus under all circumstances. With prescaler settings of 0 this is a given (i.e., no caution has to be applied).

Example: for 1 Mbit CTIM = b'10000100 (PSS = 5; PS1 = 2). Example for 500 kbit CTIM = b'01011100 (PSS = 3; PS1 = 8). – all at 10 MHz CKI and CSCAL = 0.

CAN BUS CONTROL REGISTER (CBUS) (00BA)

Re-served	RIAF	TxE1	TxE0	RxREF1	RxREF0	Re-served	FMOD
Bit 7							Bit 0

Reserved This bit is reserved and must be zero.

RIAF Receive identifier acceptance filter bit

If the RIAF bit is set to zero, bits 4 to 10 of the received identifier are compared with the mask bits of RID4..RID10 and if the corresponding bits match, the message is accepted. If the RIAF bit is set to a one, the filter function is disabled and all messages independent of the identifier will be accepted.

TxE0, TxE1 Tx0 Output Driver Enable

TABLE 5. Output Drivers

TxE1	TxE0	Output
0	0	Tx0, Tx1 TRI-STATE, CAN input comparator disabled
0	1	Tx0 enabled
1	0	Tx1 enabled
1	1	Tx0 and Tx1 enabled

Bus synchronization of the device is done in the following way:

If the output was disabled (TxE1, TxE0 = "0") and either TxE1 or TxE0, or both are set to 1, the device will not start transmission or reception of a frame until eleven consecutive "recessive" bits have been received. Resetting the TxE1 and TxE0 bits will disable the output drivers and the CAN input comparator. All other CAN related registers and flags will be unaffected. It is recommended that the user reset the TxE1 and TxE0 bits before switching the device into the HALT mode (the CAN receive wakeup will still work) in order to reduce current consumption and to assure a proper resynchronization to the bus after exiting the HALT mode.

Note: A "bus off" condition will also cause Tx0 and Tx1 to be at TRI-STATE (independent of the values of the TxE1 and TxE0 bits).

RXREF1 Reference voltage applied to Rx1 if bit is set

RXREF0 Reference voltage applied to Rx0 if bit is set

FMOD Fault Confinement Mode select

Setting the FMOD bit to "0" (default after power on reset) will select the Standard Fault Confinement mode. In this mode the device goes from "bus off" to "error active" after monitoring 128*11 recessive bits (including bus idle) on the bus. This mode has been implemented for compatibility with existing solutions. Setting the FMOD bit to "1" will select the Enhanced Fault Confinement mode. In this mode the device goes from "bus off" to "error active" after monitoring 128 "good" messages, as indicated by the reception of 11 con-

Functional Block Description of the CAN Interface (Continued)

secutive “recessive” bits including the End of Frame, whereas the standard mode may time out after 128 x 11 recessive bits (e.g., bus idle).

TRANSMIT CONTROL/STATUS (TCNTL) (00BB)

NS1	NS0	TERR	RERR	CEIE	TIE	RIE	TXSS
Bit 7							Bit 0

NS1..NS0 Node Status, i.e., Error Status.

TABLE 6. Node Status

NS1	NS0	Output
0	0	Error active
0	1	Error passive
1	0	Bus off
1	1	Bus off

The Node Status bits are read only.

TERR Transmit Error

This bit is automatically set when an error occurs during the transmission of a frame. TERR can be programmed to generate an interrupt by setting the Can Error Interrupt Enable bit (CEIE). This bit must be cleared by the user’s software.

Note: This is used for messages for more than two bytes. If an error occurs during the transmission of a frame with more than 2 data bytes, the user’s software has to handle the correct reloading of the data bytes to the TxD registers for retransmission of the frame. For frames with 2 or fewer data bytes the interface logic of this chip does an automatic retransmission. Regardless of the number of data bytes, the user’s software must reset this bit if CEIE is enabled. Otherwise a new interrupt will be generated immediately after return from the interrupt service routine.

RERR Receiver Error

This bit is automatically set when an error occurred during the reception of a frame. RERR can be programmed to generate an interrupt by setting the Can Error Interrupt Enable bit (CEIE). This bit has to be cleared by the user’s software.

CEIE CAN Error Interrupt Enable

If set by the user’s software, this bit enables the transmit and receive error interrupts. The interrupt pending flags are TERR and RERR. Resetting this bit with a pending error interrupt will inhibit the interrupt, but will not clear the cause of the interrupt (RERR or TERR). If the bit is then set without clearing the cause of the interrupt, the interrupt will reoccur.

TIE Transmit Interrupt Enable

If set by the user’s software, this bit enables the transmit interrupt. (See TBE and TXPND.) Resetting this bit with a pending transmit interrupt will inhibit the interrupt, but will not clear the cause of the interrupt. If the bit is then set without clearing the cause of the interrupt, the interrupt will reoccur.

RIE Receive Interrupt Enable

If set by the user’s software, this bit enables the receive interrupt or a remote transmission request interrupt (see RBF, RFV and RRTR). Resetting this bit with a pending receive interrupt will inhibit the interrupt, but will not clear the cause of the interrupt. If the bit is then set without clearing the cause of the interrupt, the interrupt will reoccur.

TXSS Transmission Start/Stop

This bit is set by the user’s software to initiate the transmission of a frame. Once this bit is set, a transmission is pending, as indicated by the TXPND flag being set. It can be reset

by software to cancel a pending transmission. Resetting the TXSS bit will only cancel a transmission, if the transmission of a frame hasn’t been started yet (bus idle), if arbitration has been lost (receiving) or if an error occurs during transmission. If the device has already started transmission (won arbitration) the TXPND and TXSS flags will stay set until the transmission is completed, even if the user’s software has written zero to the TXSS bit. If one or more data bytes are to be transmitted, care must be taken by the user, that the Transmit Data Register(s) have been loaded before the TXSS bit is set. TXSS will be cleared on three conditions only: Successful completion of a transmitted message; successful cancellation of a pending transmission; Transition of the CAN interface to the bus-off state.

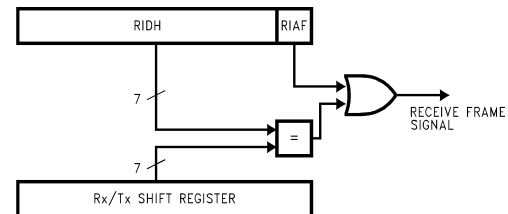

DS012067-52

FIGURE 20. Acceptance Filter Block-Diagram

Writing a zero to the TXSS bit will request cancellation of a pending transmission but TXSS will not be cleared until completion of the operation. If an error occurs during transmission of a frame, the logic will check for cancellation requests prior to restarting transmission. If zero has been written to TXSS, retransmission will be canceled.

RECEIVE/TRANSMIT STATUS (RTSTAT) (Address X’00BC)

TBE	TXPND	RRTR	ROLD	RORN	RFV	RCV	RBF
1	0	0	0	0	0	0	0
Bit 7							Bit 0

This register is read only.

TBE Transmit Buffer Empty

This bit is set as soon as the TxD2 register is copied into the Rx/Tx shift register, i.e., the 1st data byte of each pair has been transmitted. The TBE bit is automatically reset if the TxD2 register is written (the user should write a dummy byte to the TxD2 register when transmitting an odd number of bytes of zero bytes). TBE can be programmed to generate an interrupt by setting the Transmit Interrupt Enable bit (TIE). When servicing the interrupt the user has to make sure that TBE gets cleared by executing a WRITE instruction on the TxD2 register, otherwise a new interrupt will be generated immediately after return from the interrupt service routine. The TBE bit is read only. It is set to 1 upon reset. TBE is also set upon completion of transmission of a valid message.

TXPND Transmission Pending

This bit is set as soon as the Transmit Start/Stop (TXSS) bit is set by the user. It will stay set until the frame was successfully transmitted, until the transmission was successfully canceled by writing zero to the Transmission Start/Stop bit (TXSS), or the device enters the bus-off state. Resetting the TXSS bit will only cancel a transmission if the transmission of a frame hasn’t been started yet (bus idle) or if arbitration has been lost (receiving). If the device has already started transmission (won arbitration) the TXPND flag will stay set until the transmission is completed, even if the user’s soft-

Functional Block Description of the CAN Interface (Continued)

ware has requested cancellation of the message. If an error occurs during transmission, a requested cancellation may occur prior to the beginning of retransmission.

RRTR Received Remote Transmission Request

This bit is set when the remote transmission request (RTR) bit in a received frame was set. It is automatically reset through a read of the RXD1 register.

To detect RRTR the user can either poll this flag or enable the receive interrupt (the reception of a remote transmission request will also cause an interrupt if the receive interrupt is enabled). If the receive interrupt is enabled, the user should check the RRTR flag in the service routine in order to distinguish between a RRTR interrupt and a RBF interrupt. It is the responsibility of the user to clear this bit by reading the RXD1 register, before the next frame is received.

ROLD Received Overload Frame

This bit is automatically set when an Overload Frame was received on the bus. It is automatically reset through a read of the Receive/Transmit Status register. It is the responsibility of the user to clear this bit by reading the Receive/Transmit Status register, before the next frame is received.

RORN Receiver Overrun

This bit is automatically set on an overrun of the receive data register, i.e., if the user's program does not maintain the RxDn registers when receiving a frame. It is automatically reset through a read of the Receive/Transmit Status register. It is the responsibility of the user to clear this bit by reading the Receive/Transmit Status register before the next frame is received.

RFV Received Frame Valid

This bit is set if the received frame is valid, i.e., after the penultimate bit of the End of Frame is received. It is automatically reset through a read of the Receive/Transmit Status register. It is the responsibility of the user to clear this bit by reading the receive/transmit status register (RTSTAT), before the next frame is received. RFV will cause a Receive Interrupt if enabled by RIE. The user should be careful to read the last data byte (RxD1) of odd length messages (1, 3, 5 or 7 data bytes) on receipt of RFV. RFV is the only indication that the last byte of the message has been received.

RCV Receive Mode

This bit is set after the data length code of a message that passes the device's acceptance filter has been received. It is automatically reset after the CRC-delimiter of the same frame has been received. It indicates to the user's software that arbitration is lost and that data is coming in for that node.

RBF Receive Buffer Full

This bit is set if the second Rx data byte was received. It is reset automatically, after the RxD1-Register has been read by the software. RBF can be programmed to generate an interrupt by setting the Receive Interrupt Enable bit (RIE). When servicing the interrupt, the user has to make sure that RBF gets cleared by executing a LD instruction from the RxD1 register, otherwise a new interrupt will be generated immediately after return from the interrupt service routine. The RBF bit is read only.

TRANSMIT ERROR COUNTER (TEC) (Address X'00BD)

TEC7	TEC6	TEC5	TEC4	TEC3	TEC2	TEC1	TEC0
Bit 7							Bit 0

This register is read/write.

For test purposes and to identify the node status, the transmit error counter, an 8-bit error counter, is mapped into the data memory. If the lower seven bits of the counter overflow, i.e., TEC7 is set, the device is error passive.

CAUTION

To prevent interference with the CAN fault confinement, the user must not write to the REC/TEC registers. Both counters are automatically updated following the CAN specification.

RECEIVE ERROR COUNTER (REC) (00BE)

ROVL	REC6	REC5	REC4	REC3	REC2	REC1	REC0
Bit 7							Bit 0

This register is read/write.

ROVL receive error counter overflow

For test purposes and to identify the node status the receive error counter, a 7-bit error counter, is mapped into the data memory. If the counter overflows the ROVL bit is set to indicate that the device is error passive and won't transmit any active error frames. If ROVL is set then the counter is frozen.

MESSAGE IDENTIFICATION

a. Transmitted Message

The user can select all 11 Transmit Identifier Bits to transmit any message which fulfills the CAN2.0, part B spec without an extended identifier (see note below). Fully automatic retransmission is supported for messages no longer than 2 bytes.

b. Received Messages

The lower four bits of the Receive Identifier are don't care, i.e., the controller will receive all messages that fit in that window (16 messages). The upper 7 bits can be defined by the user in the Receive Identifier High Register to mask out groups of messages. If the RIAF bit is set, all messages will be received.

Note: The CAN interface tolerates the extended CAN frame format of 29 identifier bits and gives an acknowledgment. If an error occurs the receive error counter will be increased, and decreased if the frame is valid.

BUS SYNCHRONIZATION DURING OPERATION

Resetting the TxEN1 and TxEN0 bits in Bus Control Register will disable the output drivers and do a resynchronization to the bus. All other CAN related registers and flags will be unaffected.

Bus synchronization of the device in this case is done in the following way:

If the output was disabled (TxEN1, TxEN0 = "0") and either TxEN1 or TxEN0, or both are set to 1, the device will not start transmission or reception of a frame until eleven consecutive "recessive" bits have been received.

A "bus off" condition will also cause the output drivers Tx1 and Tx0 to be at TRI-STATE (independent of the status of TxEN1 and TxEN0). The device will switch from "bus off" to "error active" mode as described under the FMOD-bit description (see Can Bus Control register). This will ensure that the device is synchronized to the bus, before starting to transmit or receive.

For information on bus synchronization and status of the CAN related registers after external reset refer to the RESET section.

Functional Block Description of the CAN Interface (Continued)

ON-CHIP VOLTAGE REFERENCE

The on-chip voltage reference is a ratiometric reference. For electrical characteristics of the voltage reference refer to the electrical specifications section.

ANALOG SWITCHES

Analog switches are used for selecting between Rx0 and V_{REF} and between Rx1 and V_{REF} .

Basic CAN Concepts

The following paragraphs provide a generic overview of the basic concepts of the Controller Area Network (CAN) as described in *Chapter 4 of ISO/DIS11519-1*. Implementation related issues of the National Semiconductor device will be discussed as well.

This device will process standard frame format only. Extended frame formats will be acknowledged, however the data will be discarded. For this reason the description of frame formats in the following section will cover only the standard frame format.

The following section provides some more detail on how the device will handle received extended frames:

If the device's remote identifier acceptance filter bit (RIAF) is set to "1", extended frame messages will be acknowledged. However, the data will be discarded and the device will not reply to a remote transmission request received in extended frame format. If the device's RIAF bit is set to "0", the upper 7 received ID bits of an extended frame that match the device's receive identifier (RID) acceptance filter bits, are stroed in the device's RID register. However, the device does not reply to an RTR and any data is discarded. The device will only acknowledge the message.

MULTI-MASTER PRIORITY BASED BUS ACCESS

The CAN protocol is message based protocol that allows a total of 2032 ($= 2^{11} - 16$) different messages in the standard format and 512 million ($= 2^{29} - 16$) different messages in the extended frame format.

MULTICAST FRAME TRANSFER BY ACCEPTANCE FILTERING

Every CAN Frame is put on the common bus. Each module receives every frame and filters out the frames which are not required for the module's task.

REMOTE DATA REQUEST

A CAN master module has the ability to set a specific bit called the "remote transmission request bit" (RTR) in a frame. This causes another module, either another master or a slave, to transmit a data frame after the current frame has been completed.

SYSTEM FLEXIBILITY

Additional modules can be added to an existing network without a configuration change. These modules can either perform completely new functions requiring new data or process existing data to perform a new function.

SYSTEM WIDE DATA CONSISTENCY

As the CAN network is message oriented, a message can be used like a variable which is automatically updated by the controlling processor. If any module cannot process information it can send an overload frame. The device is incapable of initiating an overload frame, but will join an overload frame initiated by another device as required by CAN specifications.

NON-DESTRUCTIVE CONTENTION-BASED ARBITRATION

The CAN protocol allows several transmitting modules to start a transmission at the same time as soon as they monitor the bus to be idle. During the start of transmission every node monitors the bus line to detect whether its message is overwritten by a message with a higher priority. As soon as a transmitting module detects another module with a higher priority accessing the bus, it stops transmitting its own frame and switches to receive mode. For illustration see *Figure 21*.

AUTOMATIC RETRANSMISSION OF FRAMES

If a data or remote frame is overwritten by either a higher-prioritized data frame, remote frame or an error frame, the transmitting module will automatically retransmit it. This device will handle the automatic retransmission of up to two data bytes automatically. Messages with more than 2 data bytes require the user's software to update the transmit registers.

ERROR DETECTION AND ERROR SIGNALING

All messages on the bus are checked by each CAN node and acknowledge if they are correct. If any node detects an error it starts the transmission of an error frame.

Switching Off Defective Nodes

There are two error counters, one for transmitted data and one for received data, which are incremented, depending on the error type, as soon as an error occurs. If either counter goes beyond a specific value the node goes to an error state. A valid frame causes the error counters to decrease.

The device can be in one of three states with respect to error handling:

- Error active
An error active unit can participate in bus communication and sends an active ("dominant") error flag.
- Error passive
An error passive unit can participate in bus communication. However, if the unit detects an error it is not allowed to send an active error flag. The unit sends only a passive ("recessive") error flag.
- Bus off

A unit that is "bus off" has the output drivers disabled, i.e., it does not participate in any bus activity.

(See ERROR MANAGEMENT AND DETECTION for more detailed information.)

Frame Formats

INTRODUCTION

There are basically two different types of frames used in the CAN protocol.

The data transmission frames are: data/remote frame

The control frames are: error/overload frame

Frame Formats (Continued)

Note: This device cannot send an overload frame as a result of not being able to process all information. However, the device is able to recognize an overload condition and join overload frames initiated by other devices.

If no message is being transmitted, i.e., the bus is idle, the bus is kept at the "recessive" level. *Figure 22* and *Figure 23* give an overview of the various CAN frame formats.

DATA AND REMOTE FRAME

Data frames consist of seven bit fields and remote frames consist of six different bit fields:

1. Start of Frame (SOF)
2. Arbitration field
3. Control field (IDE bit, R0 bit, and DLC field)
4. Data field (not in remote frame)
5. CRC field
6. ACK field
7. End of Frame (EOF)

A remote frame has no data field and is used for requesting data from other (remote) CAN nodes. *Figure 24* shows the format of a CAN data frame.

FRAME CODING

Remote and Data Frames are NRZ codes with bit-stuffing in every bit field which holds computable information for the interface, i.e., Start of Frame arbitration field, control field, data field (if present) and CRC field.

Error and overload frames are NRZ coded without bit stuffing.

BIT STUFFING

After five consecutive bits of the same value, a stuff bit of the inverted value is inserted by the transmitter and deleted by the receiver.

Destuffed Bit Stream	100000x	011111x
Stuffed Bit Stream	1000001x	0111110x
Note: x = {0,1}		

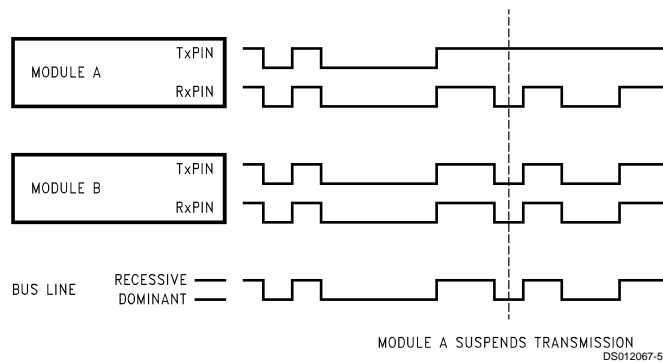
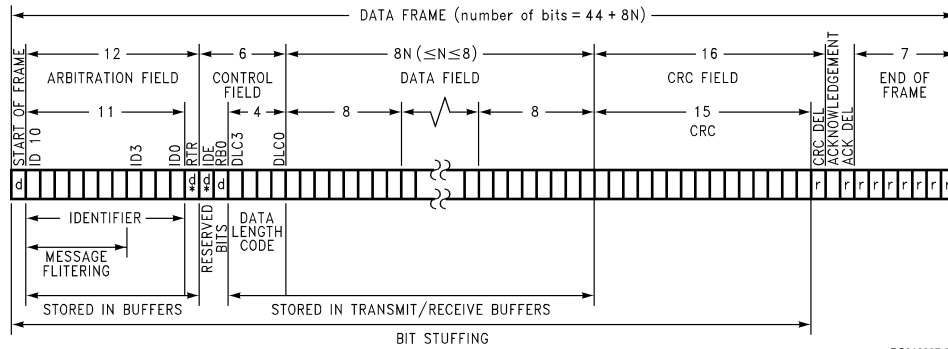
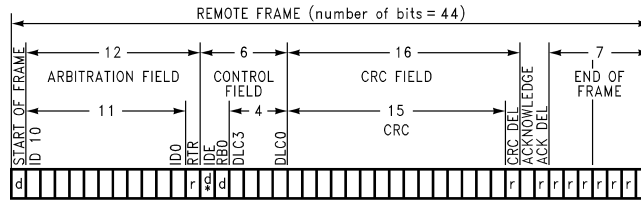

FIGURE 21. CAN Message Arbitration

Frame Formats (Continued)



DS012067-54



DS012067-55

A remote frame is identical to a data frame, except that the RTR bit is "recessive", and there is no data field.

IDE = Identifier Extension Bit

The IDE bit in the standard format is transmitted "dominant", whereas in the extended format the IDE bit is "recessive" and the id is expanded to 29 bits.

r = recessive

d = dominant

FIGURE 22. CAN Data Transmission Frames

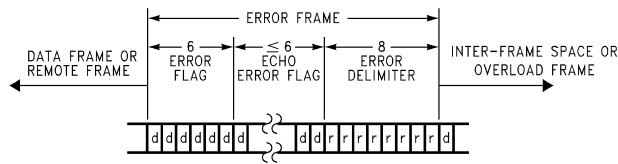

DS012067-56

An error frame can start anywhere in the middle of a frame.

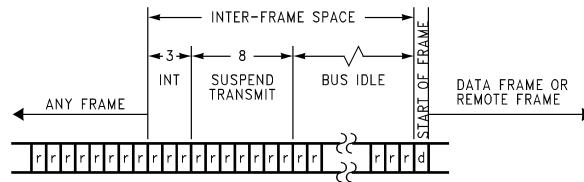

DS012067-57

INT = Intermission

Suspend Transmission is only for error passive nodes.

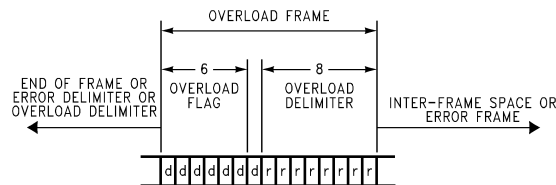

DS012067-58

An overload frame can only start at the end of a frame.

FIGURE 23. CAN Control Frames

Frame Formats (Continued)

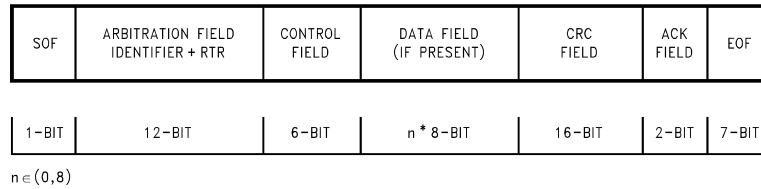

DS012067-59

FIGURE 24. CAN Frame Format

START OF FRAME (SOF)

The Start of Frame indicates the beginning of data and remote frames. It consists of a single "dominant" bit. A node is only allowed to start transmission when the bus is idle. All nodes have to synchronize to the leading edge (first edge after the bus was idle) caused by SOF of the node which starts transmission first.

ARBITRATION FIELD

The arbitration field is composed of the identifier field and the RTR (Remote Transmission Request) bit. The value of the RTR bit is "dominant" in a data frame and "recessive" in a remote frame.

CONTROL FIELD

The control field consists of six bits. It starts with two bits reserved for future expansion followed by the four-bit Data Length Code. Receivers must accept all possible combinations of the two reserved bits. Until the function of these reserved bits is defined, the transmitter only sends "0" (dominant) bits. The first reserved bit (IDE) is actually defined to indicate an extended frame with 29 Identifier bits if set to "1". CAN chips must tolerate extended frames, even if they can only understand standard frames, to prevent the destruction of an extended frames on an existing network.

The Data Length Code indicates the number of bytes in the data field. This Data Length Code consists of four bits. The data field can be of length zero. The permissible number of data bytes for a data frame ranges from 0 to 8.

DATA FIELD

The Data field consists of the data to be transferred within a data frame. It can contain 0 to 8 bytes and each byte contains 8 bits. A remote frame has no data field.

CRC FIELD

The CRC field consists of the CRC sequence followed by the CRC delimiter. The CRC sequence is derived by the transmitter from the modulo 2 division of the preceding bit fields, starting with the SOF up to the end of the data field, excluding stuff-bits, by the generator polynomial:

$$\chi^{15} + \chi^{14} + \chi^{10} + \chi^8 + \chi^7 + \chi^4 + \chi^3 + 1$$

The remainder of this division is the CRC sequence transmitted over the bus. On the receiver side the module divides all bit fields up to the CRC delimiter, excluding stuff-bits, and checks if the result is zero. This will then be interpreted as a valid CRC. After the CRC sequence a single "recessive" bit is transmitted as the CRC delimiter.

ACK FIELD

The ACK field is two bits long and contains the ACK slot and the ACK delimiter. The ACK slot is filled with a "recessive" bit by the transmitter. This bit is overwritten with a "dominant" bit by every receiver that has received a correct CRC sequence. The second bit of the ACK field is a "recessive" bit called the acknowledge delimiter. As a consequence the acknowledge flag of a valid frame is surrounded by two "recessive" bits, the CRC-delimiter and the ACK delimiter.

EOF FIELD

The End of Frame Field closes a data and a remote frame. It consists of seven "recessive" bits.

INTERFRAME SPACE

Data and remote frames are separate from every preceding frame (data, remote, error and overload frames) by the interframe space see *Figure 25* and *Figure 26* for details. Error and overload frames are not preceded by an interframe space. They can be transmitted as soon as the condition occurs. The interframe space consists of a minimum of three bit fields depending on the error state of the node.

These bit fields are coded as follows:

The intermission has the fixed form of three "recessive" bits. While this bit field is active, no node is allowed to start a transmission of a data or a remote frame. The only action to be taken is signaling an overload condition. This means that an error in this bit field would be interpreted as an overload condition. Suspend transmission has to be inserted by error-passive nodes that were transmitter for the last message. This bit field has the form of eight "recessive" bits. However, it may be overwritten by a "dominant" start-bit from another non error passive node which starts transmission. The bus idle field consists of "recessive" bits. Its length is not specified and depends on the bus load.

ERROR FRAME

The Error Frame consists of two bit fields: the error flag and the error delimiter. The error field is built up from the various error flags of the different nodes. Therefore, its length may vary from a minimum of six bits up to a maximum of twelve bits depending on when a module detects the error. Whenever a bit error, stuff error, form error, or acknowledgment error is detected by a node, this node starts transmission of the error flag at the next bit. If a CRC error is detected, transmission of the error flag starts at the bit following the acknowledge delimiter, unless an error flag for a previous error condition has already been started. *Figure 27* shows how a local fault at one module (module 2) leads to a 12-bit error frame on the bus.

The bus level may either be "dominant" for an error-active node or "recessive" for an error-passive node. An error ac-

Frame Formats (Continued)

tive node detecting an error, starts transmitting an active error flag consisting of six "dominant" bits. This causes the destruction of the actual frame on the bus. The other nodes detect the error flag as either a violation of the rule of bit-stuffing or the value of a fixed bit field is destroyed. As a consequence all other nodes start transmission of their own error flag. This means, that the error sequence which can be monitored on the bus as a maximum length of twelve bits. If an error passive node detects an error it transmits six "recessive"

bits on the bus. This sequence does not destroy a message sent by another node and is not detected by other nodes. However, if the node detecting an error was the transmitter of the frame the other modules will get an error condition by a violation of the fixed bit or stuff rule. *Figure 26* shows how an error passive transmitter transmits a passive error frame and when it is detected by the receivers.

After any module has transmitted its active or passive error flag it waits for the error delimiter which consists of eight "recessive" bits before continuing.

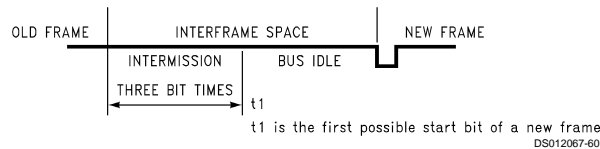

FIGURE 25. Interframe Space for Nodes Which Are Not Error Passive or Have Been Receiver for the Last Frame

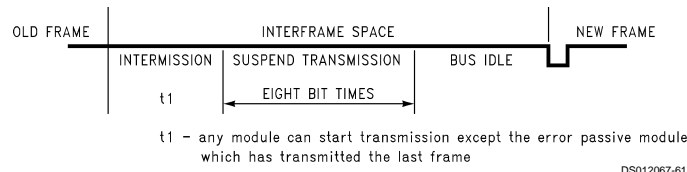

FIGURE 26. Interframe Space for Nodes Which Are Error Passive and Have Been Transmitter for the Last Frame

OVERLOAD FRAME

Like an error frame, an overload frame consists of two bit fields: the overload flag and the overload delimiter. The bit fields have the same length as the error frame field: six bits for the overload flag and eight bits for the delimiter. The overload frame can only be sent after the end of frame (EOF) field and in they way destroys the fixed form of the intermission field.

ORDER OF BIT TRANSMISSION

A frame is transmitted starting with the Start of Frame, sequentially followed by the remaining bit fields. In every bit field the MSB is transmitted first.

FRAME VALIDATION

Frames have a different validation point for transmitters and receivers. A frame is valid for the transmitter of a message, if there is no error until the end of the last bit of the End of Frame field. A frame is valid for a receiver, if there is no error until and including the end of the penultimate bit of the End of Frame.

FRAME ARBITRATION AND PRIORITY

Except for an error passive node which transmitted the last frame, all nodes are allowed to start transmission of a frame after the intermission, which can lead to two or more nodes starting transmission at the same time. To prevent a node from destroying another node's frame, it monitors the bus during transmission of the identifier field and the RTR-bit. As soon as it detects a "dominant" bit while transmitting a "recessive" bit it releases the bus, immediately stops transmission and starts receiving the frame. This causes no data or remote frame to be destroyed by another. Therefore the highest priority message with the identifier 0x000 out of 0x7EF (including the remote data request (RTR) bit) always gets the bus. This is only valid for standard CAN frame format. Note that while the CAN specification allows valid standard identifiers only in the range 0x000 to 0x7EF, the device will allow identifiers to 0x7FF.

There are three more items that should be taken into consideration to avoid unrecoverable collisions on the bus:

Frame Formats (Continued)

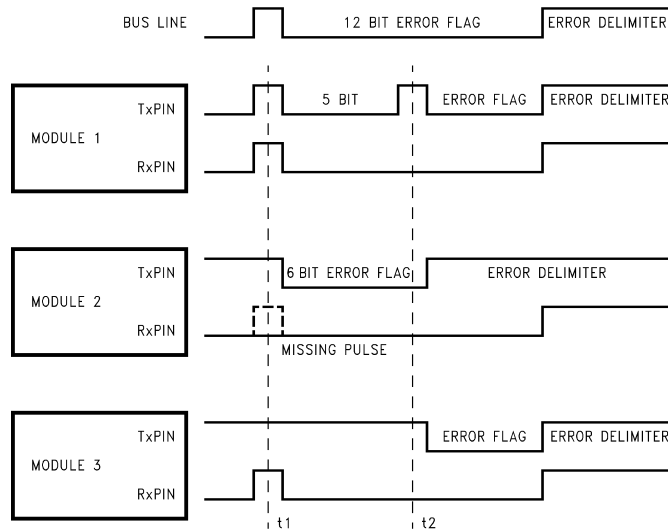

DS012067-62

module 1 = error active transmitter detects bit error at t2
 module 2 = error active receiver with a local fault at t1
 module 3 = error active receiver detects stuff error at t2

FIGURE 27. Error Frame—Error Active Transmitter

- Within one system each message must be assigned a unique identifier. This is to prevent bit errors, as one module may transmit a “dominant” data bit while the other is transmitting a “recessive” data bit. This could happen if two or more modules start transmission of a frame at the same time and all win arbitration.
- Data frames with a given identifier and a non-zero data length code may be initiated by one node only. Otherwise, in worst case, two nodes would count up to the bus-off state, due to bit errors, if they always start transmitting the same ID with different data.
- Every remote frame should have a system-wide data length code (DLC). Otherwise two modules starting transmission of a remote frame at the same time will overwrite each other's DLC which result in bit errors.

ACCEPTANCE FILTERING

Every node may perform acceptance filtering on the identifier of a data or a remote frame to filter out the messages which are not required by the node. In this way only the data of frames which match the acceptance filter is stored in the corresponding data buffers. However, every node which is not in the bus-off state and has received a correct CRC-sequence acknowledges each frame.

ERROR MANAGEMENT AND DETECTION

There are multiple mechanisms in the CAN protocol, to detect errors and to inhibit erroneous modules from disabling all bus activities.

Frame Formats (Continued)

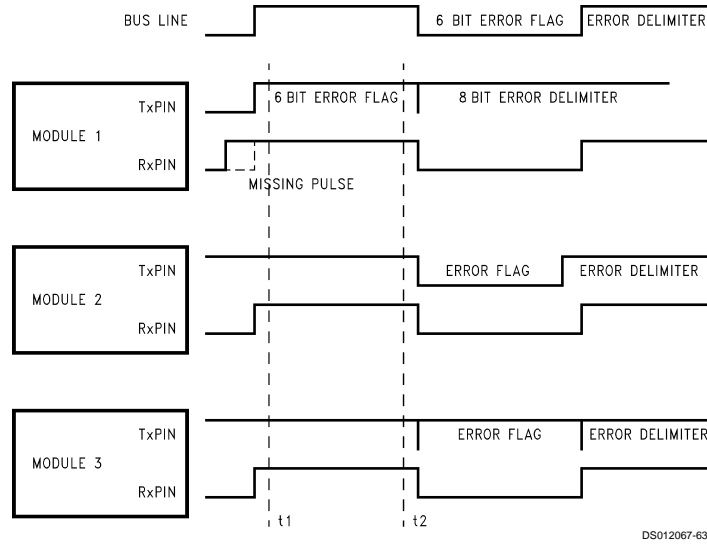

DS012067-63

module 1 = error active receiver with a local fault at t1
 module 2 = error passive transmitter detects bit error at t2
 module 3 = error passive receiver detects stuff error at t2

FIGURE 28. Error Frame — Error Passive Transmitter

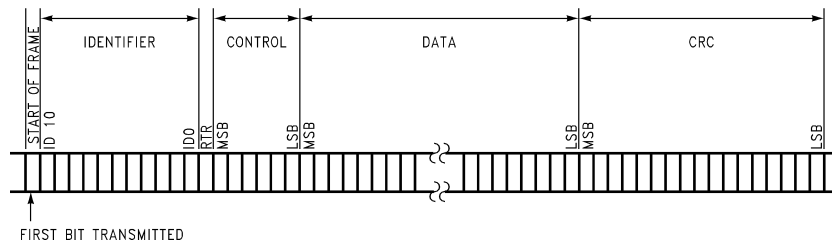

DS012067-64

FIGURE 29. Order of Bit Transmission within a CAN Frame

The following errors can be detected:

- Bit Error

A CAN device that is sending also monitors the bus. If the monitored bit value is different from the bit value that is sent, a bit error is detected. The reception of a “dominant” bit instead of a “recessive” bit during the transmission of a passive error flag, during the stuffed bit stream of the arbitration field or during the acknowledge slot, is not interpreted as a bit error.

- Stuff error

A stuff error is detected, if the bit level after 6 consecutive bit times has not changed in a message field that has to be coded according to the bit stuffing method.

- Form Error

A form error is detected, if a fixed frame bit (e.g., CRC delimiter, ACK delimiter) does not have the specified value. For a receiver a “dominant” bit during the last bit of End of Frame does NOT constitute a form error.

- Bit CRC Error

A CRC error is detected if the remainder of the CRC calculation of a received CRC polynomial is non-zero.

- Acknowledgment Error

An acknowledgment error is detected whenever a transmitting node does not get an acknowledgment from any other node (i.e., when the transmitter does not receive a “dominant” bit during the ACK frame).

The device can be in one of three states with respect to error handling:

- Error active

An error active unit can participate in bus communication and sends an active (“dominant”) error flag.

- Error passive

Frame Formats (Continued)

An error passive unit can participate in bus communication. However, if the unit detects an error it is not allowed to send an active error flag. The unit sends only a passive (“recessive”) error flag. A device is error passive when the transmit error counter is greater than 127 or when the receive error counter is greater than 127. A device becoming error passive sends an active error flag. An error passive device becomes error active again when both transmit and receive error counter are less than 128.

- Bus off

A unit that is “bus off” has the output drivers disabled, i.e., it does not participate in any bus activity. A device is bus off when the transmit error counter is greater than 255. A bus off device will become error active again in one of two ways depending on which mode is selected by the user through the Fault Confinement Mode select bit (FMODE) in the CAN Bus Control Register (CBUS). Setting the FMODE bit to “0” (default after power on reset) will select the Standard Fault Confinement mode. In this mode the device goes from “bus off” to “error active” after monitoring 128*11 recessive bits (including bus idle) on the bus. This mode has been implemented for compatibility reasons with existing solutions. Setting the FMODE bit to “1” will select the Enhanced Fault Confinement mode. In this mode the device goes from “bus off” to “error active” after monitoring 128 “good” messages, as indicated by the reception of 11 consecutive “recessive” bits including the End of Frame. The enhanced mode offers the advantage that a “bus off” device (i.e., a device with a serious fault) is not allowed to destroy any messages on the bus until other devices can transmit at least 128 messages. This is not guaranteed in the standard mode, where a defective device could seriously impact bus communication. When the device goes from “bus off” to “error active”, both error counters will have the value “0”.

In each CAN module there are two error counters to perform a sophisticated error management. The receive error counter (REC) is 7 bits wide and switches the device to the error passive state if it overflows. The transmit error counter (TEC) is 8 bits wide. If it is greater than 127, the device is switched to the error passive state. As soon as the TEC overflows, the device is switched bus-off, i.e., it does not participate in any bus activity.

The counters are modified by the device’s hardware according to the following rules:

TABLE 7. Receive Error Counter Handling

Condition	Receive Error Counter
A receiver detects a Bit Error during sending an active error flag.	Increment by 8
A receiver detects a “dominant” bit as the first bit after sending an error flag.	Increment by 8

Condition	Receive Error Counter
After detecting the 14th consecutive “dominant” bit following an active error flag or overload flag or after detecting the 8th consecutive “dominant” bit following a passive error flag. After each sequence of additional 8 consecutive “dominant” bits.	Increment by 8
Any other error condition (stuff, frame, CRC, ACK).	Increment by 1
A valid reception or transmission.	Decrement by 1 if Counter is not 0

TABLE 8. Transmit Error Counter Handling

Condition	Transmit Error Counter
A transmitter detects a Bit Error during sending an active error flag.	Increment by 8
After detecting the 14th consecutive “dominant” bit following an active error flag or overload flag or after detecting the 8th consecutive “dominant” bit following a passive error flag. After each sequence of additional 8 consecutive “dominant” bits.	Increment by 8
Any other error condition (stuff, frame, CRC, ACK).	Increment by 8
A valid reception or transmission.	Decrement by 1 if Counter is not 0

Special error handling for the TEC counter is performed in the following situations:

- A stuff error occurs during arbitration, when a transmitted “recessive” stuff bit is received as a “dominant” bit. This does not lead to an incrementation of the TEC.
- An ACK-error occurs in an error passive device and no “dominant” bits are detected while sending the passive error flag. This does not lead to an incrementation of the TEC.

Frame Formats (Continued)

- If only one device is on the bus and this device transmits a message, it will get no acknowledgment. This will be detected as an error and message will be repeated. When the device goes "error passive" and detects an acknowledge error, the TEC counter is not incremented. Therefore the device will not go from "error passive" to the "bus off" state due to such a condition.

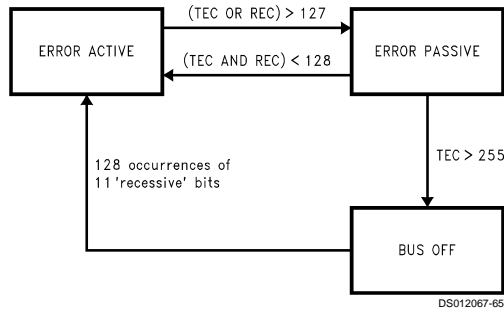

FIGURE 30. CAN Bus States

Figure 30 shows the connection of different bus states according to the error counters.

SYNCHRONIZATION

Every receiver starts with a "hard synchronization" on the falling edge of the SOF bit. One bit time consists of four bit segments: Synchronization segment, propagation segment, phase segment 1 and phase segment 2.

A falling edge of the data signal should be in the synchronization segment. This segment has the fixed length of one time quanta. To compensate for the various delays within a network, the propagation segment is used. Its length is programmable from 1 to 8 time quanta. Phase segment 1 and phase segment 2 are used to resynchronize during an active frame. The length of these segments is from 1 to 8 time quanta long.

Two types of synchronization are supported:

Hard synchronization is done with the falling edge on the bus while the bus is idle, which is then interpreted as the SOF. It restarts the internal logic.

Soft synchronization is used to lengthen or shorten the bit time while a data or remote frame is received. Whenever a falling edge is detected in the propagation segment or in phase segment 1, the segment is lengthened by a specific value, the resynchronization jump width (see Figure 32).

If a falling edge lies in the phase segment 2 (as shown in Figure 32) it is shortened by the resynchronization jump width. Only one resynchronization is allowed during one bit time. The sample point lies between the two phase segments and is the point where the received data is supposed to be valid. The transmission point lies at the end of phase segment 2 to start a new bit time with the synchronization segment.

Note 16: The resynchronization jump width (RJW) is automatically determined from the programmed value of PS. If a soft resynchronization is done during phase segment 1 or the propagation segment, then RJW will either be equal to 4 internal CAN clocks ($CKI/(1 + divider)$) or the programmed value of PS, whichever is less. PS2 will never be shorter than 1 internal CAN clock.

Note 17: (PS1 — BTL settings any PSC setting) The PS1 of the BTL should always be programmed to values greater than 1. To allow device resynchronization for positive and negative phase errors on the bus. (if PS1 is programmed to one, a bit time could only be lengthened and never shortened which basically disables half of the synchronization).

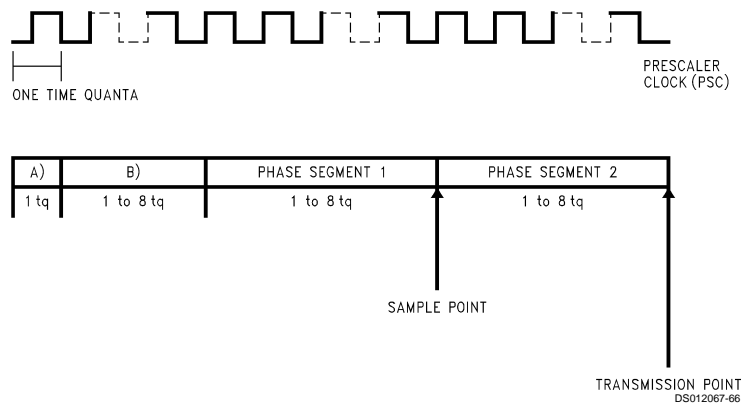

- A) Synchronization segment
- B) Propagation segment

FIGURE 31. Bit Timing

Frame Formats (Continued)

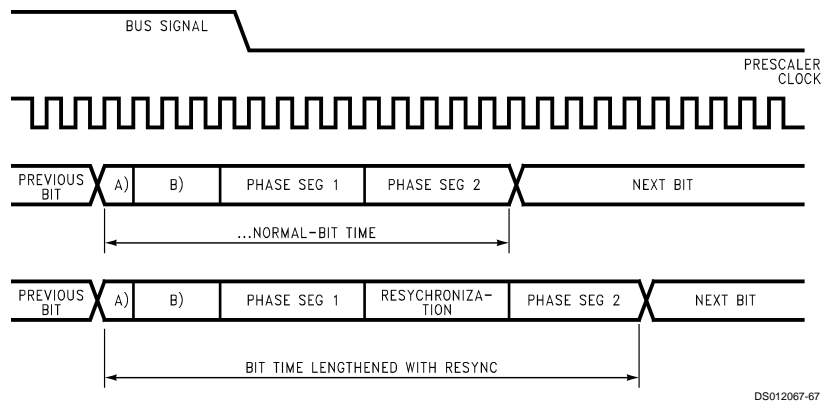

FIGURE 32. Resynchronization 1

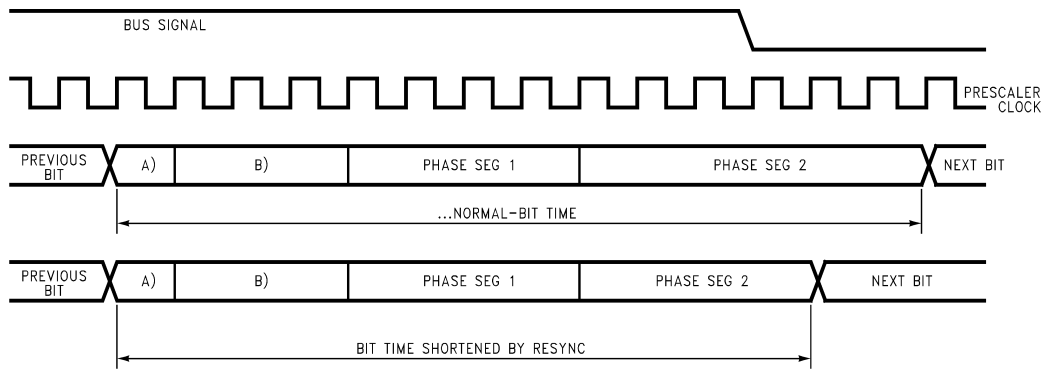

FIGURE 33. Resynchronization 2

Comparators

The device has two differential comparators. Port L is used for the comparators. The output of the comparators is multiplexed out to two pins. The following are the Port L assignments:

- L6 Comparator 2 output
- L5 Comparator 2 negative input
- L4 Comparator 2 positive input
- L3 Comparator 2 negative input
- L2 Comparator 1 output
- L1 Comparator 1 negative input
- L0 Comparator 1 positive input

Additionally the comparator output can be connected internally to the L-Port pin of the respective positive input and thereby generate an interrupt using the L-Port interrupt structure (neg/pos. edge, enable/disable).

Note that in *Figure 34*, pin L6 has a second alternate function of supporting the PWM0 output. The comparator 2 output MUST be disabled in order to use PWM0 output on L6.

Figure 34 shows the Comparator Block Diagram.

COMPARATOR CONTROL REGISTER (CMPSL) (00D3)

These bits reside in the Comparator Register

CMP2 SEL	CMP2 OE	CMP2 RD	CMP2 EN	CMP1 OE	CMP1 RD	CMP1 EN	Re- served
Bit 7							Bit 0

The register contains the following bits:

- CMP2SEL** Selects which L port pin to use for comparator2 negative input. (CMP2SEL = 0 selects L5; CMP2SEL = 1 selects pin L3).
- CMP2OE** Enables comparator 2 output ("1"=enable), CMP2EN bit must be set to enable this function.
- CMP2RD** Reads comparator 2 output internally (CMP2EN=1) Read-only, reads as a "0" if comparator not enabled.
- CMP2EN** Enables comparator 2 ("1"=enable). If comparator 2 is disabled the associated L-pins can be used as standard I/O.
- CMP1OE** Enables comparator 1 output ("1"=enable), CMP1EN bit must be set to enable this function.
- CMP1RD** Reads comparator 1 output internally (CMP1EN=1) Read-only, reads as a "0" if comparator not enabled.

Comparators (Continued)

CMP1EN Enables comparator 1 ("1"=enable). If comparator 1 is disabled the associated L-pins can be used as standard I/O.

Reserved This bit is reserved and should be zero.

The Comparator Select/Control bits are cleared on RESET (the comparator is disabled). To save power, the program should also disable the comparator before the device enters the HALT mode.

The Comparator rise and fall times are symmetrical. The user program must set up the Configuration and Data registers of the L port correctly for comparator Inputs/Output.

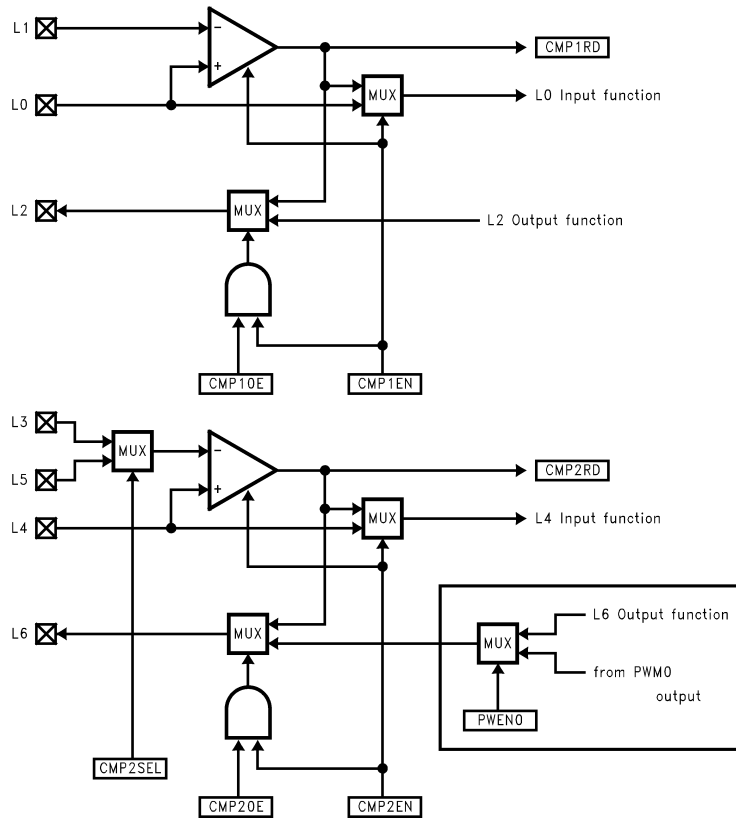

DS012067-36

The BOXED area shows logic from PWM Timer. Comparator 2 output (CMP2OE) must be disabled in order to use PWM0 output.

FIGURE 34. Comparator Block

Interrupts

INTRODUCTION

Each device supports eleven vectored interrupts. Interrupt sources include Timer 0, Timer 1, Port L Wakeup, Software Trap, MICROWIRE/PLUS, and External Input.

All interrupts force a branch to location 00FF Hex in program memory. The VIS instruction may be used to vector to the appropriate service routine from location 00FF Hex.

The Software trap has the highest priority while the default VIS has the lowest priority.

Each of the 11 maskable inputs has a fixed arbitration ranking and vector.

Figure 35 shows the Interrupt Block Diagram.

Interrupts (Continued)

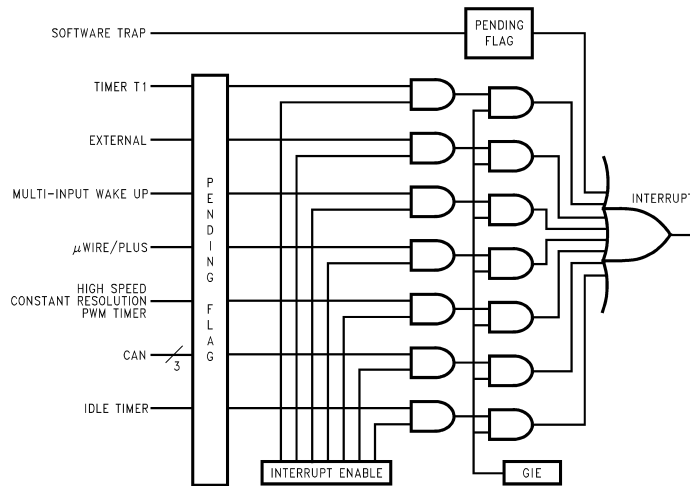

FIGURE 35. Interrupt Block Diagram

DS012067-17

MASKABLE INTERRUPTS

All interrupts other than the Software Trap are maskable. Each maskable interrupt has an associated enable bit and pending flag bit. The pending bit is set to 1 when the interrupt condition occurs. The state of the interrupt enable bit, combined with the GIE bit determines whether an active pending flag actually triggers an interrupt. All of the maskable interrupt pending and enable bits are contained in mapped control registers, and thus can be controlled by the software.

A maskable interrupt condition triggers an interrupt under the following conditions:

1. The enable bit associated with that interrupt is set.
2. The GIE bit is set.
3. The device is not processing a non-maskable interrupt. (If a non-maskable interrupt is being serviced, a maskable interrupt must wait until that service routine is completed.)

An interrupt is triggered only when all of these conditions are met at the beginning of an instruction. If different maskable interrupts meet these conditions simultaneously, the highest priority interrupt will be serviced first, and the other pending interrupts must wait.

Upon Reset, all pending bits, individual enable bits, and the GIE bit are reset to zero. Thus, a maskable interrupt condition cannot trigger an interrupt until the program enables it by setting both the GIE bit and the individual enable bit. When enabling an interrupt, the user should consider whether or not a previously activated (set) pending bit should be acknowledged. If, at the time an interrupt is enabled, any previous occurrences of the interrupt should be ignored, the associated pending bit must be reset to zero prior to enabling the interrupt. Otherwise, the interrupt may be simply enabled; if the pending bit is already set, it will immediately trigger an interrupt. A maskable interrupt is active if its associated enable and pending bits are set.

An interrupt is an asynchronous event which may occur before, during, or after an instruction cycle. Any interrupt which occurs during the execution of an instruction is not acknowledged until the start of the next normally executed instruction

is to be skipped, the skip is performed before the pending interrupt is acknowledged.

At the start of interrupt acknowledgment, the following actions occur:

1. The GIE bit is automatically reset to zero, preventing any subsequent maskable interrupt from interrupting the current service routine. This feature prevents one maskable interrupt from interrupting another one being serviced.
2. The address of the instruction about to be executed is pushed onto the stack.
3. The program counter (PC) is loaded with 00FF Hex, causing a jump to that program memory location.

The device requires seven instruction cycles to perform the actions listed above.

If the user wishes to allow nested interrupts, the interrupts service routine may set the GIE bit to 1 by writing to the PSW register, and thus allow other maskable interrupts to interrupt the current service routine. If nested interrupts are allowed, caution must be exercised. The user must write the program in such a way as to prevent stack overflow, loss of saved context information, and other unwanted conditions.

The interrupt service routine stored at location 00FF Hex should use the VIS instruction to determine the cause of the interrupt, and jump to the interrupt handling routine corresponding to the highest priority enabled and active interrupt. Alternately, the user may choose to poll all interrupt pending and enable bits to determine the source(s) of the interrupt. If more than one interrupt is active, the user's program must decide which interrupt to service.

Within a specific interrupt service routine, the associated pending bit should be cleared. This is typically done as early as possible in the service routine in order to avoid missing the next occurrence of the same type of interrupt event. Thus, if the same event occurs a second time, even while the first occurrence is still being serviced, the second occurrence will be serviced immediately upon return from the current interrupt routine.

Interrupts (Continued)

An interrupt service routine typically ends with an RETI instruction. This instruction sets the GIE bit back to 1, pops the address stored on the stack, and restores that address to the program counter. Program execution then proceeds with the next instruction that would have been executed had there been no interrupt. If there are any valid interrupts pending, the highest-priority interrupt is serviced immediately upon return from the previous interrupt.

VIS INSTRUCTION

The general interrupt service routine, which starts at address 00FF Hex, must be capable of handling all types of interrupts. The VIS instruction, together with an interrupt vector table, directs the device to the specific interrupt handling routine based on the cause of the interrupt.

VIS is a single-byte instruction, typically used at the very beginning of the general interrupt service routine at address 00FF Hex, or shortly after that point, just after the code used for context switching. The VIS instruction determines which enabled and pending interrupt has the highest priority, and causes an indirect jump to the address corresponding to that interrupt source. The jump addresses (vectors) for all possible interrupts sources are stored in a vector table.

The vector table may be as long as 32 bytes (maximum of 16 vectors) and resides at the top of the 256-byte block containing the VIS instruction. However, if the VIS instruction is at the very top of a 256-byte block (such as at 00FF Hex), the vector table resides at the top of the next 256-byte block. Thus, if the VIS instruction is located somewhere between 00FF and 01DF Hex (the usual case), the vector table is located between addresses 01E0 and 01FF Hex. If the VIS instruction is located between 01FF and 02DF Hex, then the vector table is located between addresses 02E0 and 02FF Hex, and so on.

Each vector is 15 bits long and points to the beginning of a specific interrupt service routine somewhere in the 32 kbyte memory space. Each vector occupies two bytes of the vector table, with the higher-order byte at the lower address. The vectors are arranged in order of interrupt priority. The vector of the maskable interrupt with the lowest rank is located at 0yE0 (higher-order byte) and 0yE1 (lower-order byte). The next priority interrupt is located at 0yE2 and 0yE3, and so forth in increasing rank. The Software Trap has the highest rank and its vector is always located at 0yFE and 0yFF. The number of interrupts which can become active defines the size of the table.

Table 9 shows the types of interrupts, the interrupt arbitration ranking, and the locations of the corresponding vectors in the vector table.

The vector table should be filled by the user with the memory locations of the specific interrupt service routines. For example, if the Software Trap routine is located at 0310 Hex, then the vector location 0yFE and -0yFF should contain the data 03 and 10 Hex, respectively. When a Software Trap interrupt occurs and the VIS instruction is executed, the program jumps to the address specified in the vector table.

The interrupt sources in the vector table are listed in order of rank, from highest to lowest priority. If two or more enabled and pending interrupts are detected at the same time, the one with the highest priority is serviced first. Upon return from the interrupt service routine, the next highest-level pending interrupt is serviced.

If the VIS instruction is executed, but no interrupts are enabled and pending, the lowest-priority interrupt vector is used, and a jump is made to the corresponding address in the vector table. This is an unusual occurrence, and may be the result of an error. It can legitimately result from a change in the enable bits or pending flags prior to the execution of the VIS instruction, such as executing a single cycle instruction which clears an enable flag at the same time that the pending flag is set. It can also result, however, from inadvertent execution of the VIS command outside of the context of an interrupt.

The default VIS interrupt vector can be useful for applications in which time critical interrupts can occur during the servicing of another interrupt. Rather than restoring the program context (A, B, X, etc.) and executing the RETI instruction, an interrupt service routine can be terminated by returning to the VIS instruction. In this case, interrupts will be serviced in turn until no further interrupts are pending and the default VIS routine is started. After testing the GIE bit to ensure that execution is not erroneous, the routine should restore the program context and execute the RETI to return to the interrupted program.

This technique can save up to fifty instruction cycles (t_c), or more, (50 μ s at 10 MHz oscillator) of latency for pending interrupts with a penalty of fewer than ten instruction cycles if no further interrupts are pending.

To ensure reliable operation, the user should always use the VIS instruction to determine the source of an interrupt. Although it is possible to poll the pending bits to detect the source of an interrupt, this practice is not recommended. The use of polling allows the standard arbitration ranking to be altered, but the reliability of the interrupt system is compromised. The polling routine must individually test the enable and pending bits of each maskable interrupt. If a Software Trap interrupt should occur, it will be serviced last, even though it should have the highest priority. Under certain conditions, a Software Trap could be triggered but not serviced, resulting in an inadvertent "locking out" of all maskable interrupts by the Software Trap pending flag. Problems such as this can be avoided by using VIS instruction.

Interrupts (Continued)

TABLE 9. Interrupt Vector Table

Arbitration Ranking	Source	Vector Address Hi-Low Byte
1	Software Trap	0yFE–0yFF
2	Reserved	0yFC–0yFD
3	CAN Receive	0yFA–0yFB
4	CAN Error (transmit/receive)	0yF8–0yF9
5	CAN Transmit	0yF6–0yF7
6	Pin G0 Edge	0yF4–0yF5
7	IDLE Timer Underflow	0yF2–0yF3
8	Timer T1A/Underflow	0yF0–0yF1
9	Timer T1B	0yEE–0yEF
10	MICROWIRE/PLUS	0yEC–0yED
11	PWM timer	0yEA–0yEB
12	Reserved	0yE8–0yE9
13	Reserved	0yE6–0yE7
14	Reserved	0yE4–0yE5
15	Port L/Wake Up	0yE2–0yE3
16	Default VIS Interrupt	0yE0–0yE1

Note 18: y is VIS page, y ≠ 0

If, by accident, a VIS gets executed and no interrupt is active, then the PC (Program Counter) will branch to a vector located at 0yE0-0yE1.

VIS Execution

When the VIS instruction is executed it activates the arbitration logic. The arbitration logic generates an even number between E0 and FE (E0, E2, E4, E6 etc...) depending on which active interrupt has the highest arbitration ranking at the time of the 1st cycle of VIS is executed. For example, if the software trap interrupt is active, FE is generated. If the external interrupt is active and the software trap interrupt is not, then FA is generated and so forth. If the only active interrupt is software trap, then E0 is generated. This number re-

places the lower byte of the PC. The upper byte of the PC remains unchanged. The new PC is therefore pointing to the vector of the active interrupt with the highest arbitration ranking. This vector is read from program memory and placed into the PC which is now pointed to the 1st instruction of the service routine of the active interrupt with the highest arbitration ranking.

Figure 36 illustrates the different steps performed by the VIS instruction. Figure 37 shows a flowchart for the VIS instruction.

The non-maskable interrupt pending flag is cleared by the RPND (Reset Non-Maskable Pending Bit) instruction (under certain conditions) and upon RESET.

Interrupts (Continued)

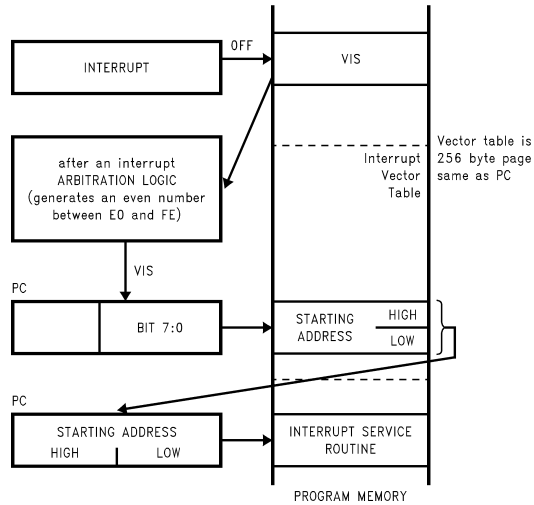

DS012067-29

FIGURE 36. VIS Operation

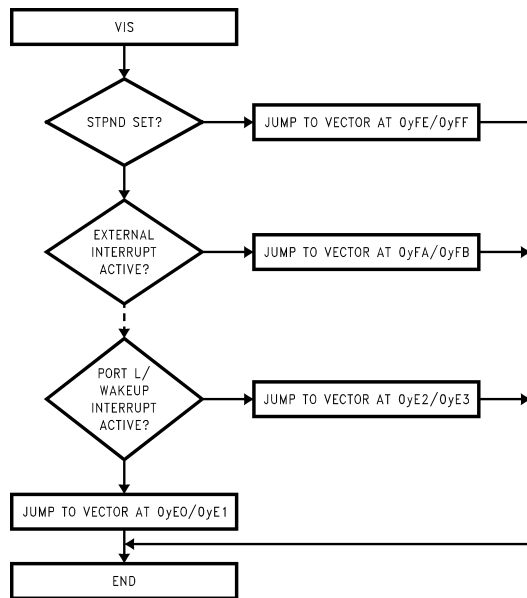

DS012067-30

FIGURE 37. VIS Flowchart

Interrupts (Continued)

Programming Example: External Interrupt

```
PSW          =00EF
CNTRL        =00EE
RBIT        0,PORTGC
RBIT        0,PORTGD      ; G0 pin configured Hi-Z
SBIT        IEDG, CNTRL   ; Ext interrupt polarity; falling edge
SBIT        EXEN, PSW     ; Enable the external interrupt
SBIT        GIE, PSW     ; Set the GIE bit
WAIT:       JP          WAIT      ; Wait for external interrupt
.
.
.
.=0FF      ; The interrupt causes a
VIS        ; branch to address 0FF
           ; The VIS causes a branch to
           ; interrupt vector table
.
.
.
.=01FA     ; Vector table (within 256 byte
.ADDRW SERVICE ; of VIS inst.) containing the ext
           ; interrupt service routine
.
.
INT_EXIT:   RETI
.
SERVICE:  RBIT      EXPND, PSW   ; Interrupt Service Routine
           ; Reset ext interrupt pend. bit
.
.
.
JP      INT_EXIT      ; Return, set the GIE bit
```

Interrupts (Continued)

NON-MASKABLE INTERRUPT

Pending Flag

There is a pending flag bit associated with the non-maskable interrupt, called STPND. This pending flag is not memory-mapped and cannot be accessed directly by the software.

The pending flag is reset to zero when a device Reset occurs. When the non-maskable interrupt occurs, the associated pending bit is set to 1. The interrupt service routine should contain an RPND instruction to reset the pending flag to zero. The RPND instruction always resets the STPND flag.

Software Trap

The Software Trap is a special kind of non-maskable interrupt which occurs when the INTR instruction (used to acknowledge interrupts) is fetched from program memory and placed in the instruction register. This can happen in a variety of ways, usually because of an error condition. Some examples of causes are listed below.

If the program counter incorrectly points to a memory location beyond the available program memory space, the non-existent or unused memory location returns zeroes which is interpreted as the INTR instruction.

If the stack is popped beyond the allowed limit (address 06F Hex), a 7FFF will be loaded into the PC, if this last location in program memory is unprogrammed or unavailable, a Software Trap will be triggered.

A Software Trap can be triggered by a temporary hardware condition such as a brownout or power supply glitch.

The Software Trap has the highest priority of all interrupts. When a Software Trap occurs, the STPND bit is set. The GIE bit is not affected and the pending bit (not accessible by the user) is used to inhibit other interrupts and to direct the program to the ST service routine with the VIS instruction. Nothing can interrupt a Software Trap service routine except for another Software Trap. The STPND can be reset only by the RPND instruction or a chip Reset.

The Software Trap indicates an unusual or unknown error condition. Generally, returning to normal execution at the point where the Software Trap occurred cannot be done reliably. Therefore, the Software Trap service routine should reinitialize the stack pointer and perform a recovery procedure that restarts the software at some known point, similar to a device Reset, but not necessarily performing all the same functions as a device Reset. The routine must also execute the RPND instruction to reset the STPND flag. Otherwise, all other interrupts will be locked out. To the extent possible, the interrupt routine should record or indicate the context of the device so that the cause of the Software Trap can be determined.

If the user wishes to return to normal execution from the point at which the Software Trap was triggered, the user must first execute RPND, followed by RETSK rather than RETI or RET. This is because the return address stored on the stack is the address of the INTR instruction that triggered the interrupt. The program must skip that instruction in order to proceed with the next one. Otherwise, an infinite loop of Software Traps and returns will occur.

Programming a return to normal execution requires careful consideration. If the Software Trap routine is interrupted by another Software Trap, the RPND instruction in the service routine for the second Software Trap will reset the STPND

flag; upon return to the first Software Trap routine, the STPND flag will have the wrong state. This will allow maskable interrupts to be acknowledged during the servicing of the first Software Trap. To avoid problems such as this, the user program should contain the Software Trap routine to perform a recovery procedure rather than a return to normal execution.

Under normal conditions, the STPND flag is reset by a RPND instruction in the Software Trap service routine. If a programming error or hardware condition (brownout, power supply glitch, etc.) sets the STPND flag without providing a way for it to be cleared, all other interrupts will be locked out. To alleviate this condition, the user can use extra RPND instructions in the main program and in the WATCHDOG service routine (if present). There is no harm in executing extra RPND instructions in these parts of the program.

PORT L INTERRUPTS

Port L provides the user with an additional eight fully selectable, edge sensitive interrupts which are all vectored into the same service subroutine.

The interrupt from Port L shares logic with the wake up circuitry. The register WKEN allows interrupts from Port L to be individually enabled or disabled. The register WKEDG specifies the trigger condition to be either a positive or a negative edge. Finally, the register WKPND latches in the pending trigger conditions.

The GIE (Global Interrupt Enable) bit enables the interrupt function.

A control flag, LPEN, functions as a global interrupt enable for Port L interrupts. Setting the LPEN flag will enable interrupts and vice versa. A separate global pending flag is not needed since the register WKPND is adequate.

Since Port L is also used for waking the device out of the HALT or IDLE modes, the user can elect to exit the HALT or IDLE modes either with or without the interrupt enabled. If he elects to disable the interrupt, then the device will restart execution from the instruction immediately following the instruction that placed the microcontroller in the HALT or IDLE modes. In the other case, the device will first execute the interrupt service routine and then revert to normal operation. (See HALT MODE for clock option wakeup information.)

INTERRUPT SUMMARY

The device uses the following types of interrupts, listed below in order of priority:

1. The Software Trap non-maskable interrupt, triggered by the INTR (00 opcode) instruction. The Software Trap is acknowledged immediately. This interrupt service routine can be interrupted only by another Software Trap. The Software Trap should end with two RPND instructions followed by a restart procedure.
2. Maskable interrupts, triggered by an on-chip peripheral block or an external device connected to the device. Under ordinary conditions, a maskable interrupt will not interrupt any other interrupt routine in progress. A maskable interrupt routine in progress can be interrupted by the non-maskable interrupt request. A maskable interrupt routine should end with an RETI instruction or, prior to restoring context, should return to execute the VIS instruction. This is particularly useful when exiting long interrupt service routines if the time between interrupts is short. In this case the RETI instruction would only be executed when the default VIS routine is reached.

Detection of Illegal Conditions

The device can detect various illegal conditions resulting from coding errors, transient noise, power supply voltage drops, runaway programs, etc.

Reading of undefined ROM gets zeroes. The opcode for software interrupt is zero. If the program fetches instructions from undefined ROM, this will force a software interrupt, thus signaling that an illegal condition has occurred.

The subroutine stack grows down for each call (jump to subroutine), interrupt, or PUSH, and grows up for each return or POP. The stack pointer is initialized to RAM location 02F Hex during reset. Consequently, if there are more returns than calls, the stack pointer will point to addresses 030 and 031 Hex (which are undefined RAM). Undefined RAM from addresses 030 to 03F Hex is read as all 1's, which in turn will cause the program to return to address 7FFF Hex. This is an undefined ROM location and the instruction fetched (all 0's) from this location will generate a software interrupt signaling an illegal condition.

Thus, the chip can detect the following illegal conditions:

1. Executing from undefined ROM.
2. Over "POP"ing the stack by having more returns than calls.

When the software interrupt occurs, the user can re-initialize the stack pointer and do a recovery procedure before restarting (this recovery program is probably similar to that following reset, but might not contain the same program initialization procedures).

MICROWIRE/PLUS

MICROWIRE/PLUS is a serial synchronous communications interface. The MICROWIRE/PLUS capability enables the device to interface with any of National Semiconductor's MICROWIRE peripherals (i.e., A/D converters, display drivers, E2PROMs etc.) and with other microcontrollers which support the MICROWIRE interface. It consists of an 8-bit serial shift register (SIO) with serial data input (SI), serial data output (SO) and serial shift clock (SK). *Figure 38* shows a block diagram of the MICROWIRE/PLUS logic.

The shift clock can be selected from either an internal source or an external source. Operating the MICROWIRE/PLUS arrangement with the internal clock source is called the Master mode of operation. Similarly, operating the MICROWIRE arrangement with an external shift clock is called the Slave mode of operation.

The CNTRL register is used to configure and control the MICROWIRE/PLUS mode. To use the MICROWIRE/PLUS, the MSEL bit in the CNTRL register is set to one. In the master mode the SK clock rate is selected by the two bits, SL0 and SL1, in the CNTRL register. *Table 10* details the different clock rates that may be selected.

MICROWIRE/PLUS OPERATION

Setting the BUSY bit in the PSW register causes the MICROWIRE/PLUS to start shifting the data. It gets reset when eight data bits have been shifted. The user may reset the BUSY bit by software to allow less than 8 bits to shift. If enabled, an interrupt is generated when eight data bits have been shifted. The device may enter the MICROWIRE/PLUS mode either as a Master or as a Slave. *Figure 39* shows how two COP888 family microcontrollers and several peripherals may be interconnected using the MICROWIRE/PLUS arrangements.

Warning:

The SIO register should only be loaded when the SK clock is low. Loading the SIO register while the SK clock is high will result in undefined data in the SIO register. SK clock is normally low when not shifting.

Setting the BUSY flag when the input SK clock is high in the MICROWIRE/PLUS slave mode may cause the current SK clock for the SIO shift register to be narrow. For safety, the BUSY flag should only be set when the input SK clock is low.

MICROWIRE/PLUS Master Mode Operation

In the MICROWIRE/PLUS Master mode of operation the shift clock (SK) is generated internally. The MICROWIRE Master always initiates all data exchanges. The MSEL bit in the CNTRL register must be set to enable the SO and SK functions onto the G Port. The SO and SK pins must also be selected as outputs by setting appropriate bits in the Port G configuration register. *Table 11* summarizes the bit settings required for Master or Slave mode of operation.

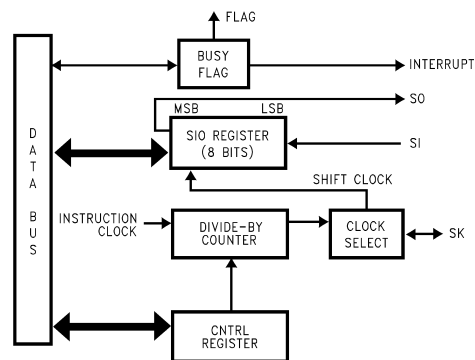

DS012067-37

FIGURE 38. MICROWIRE/PLUS Block Diagram

MICROWIRE/PLUS (Continued)

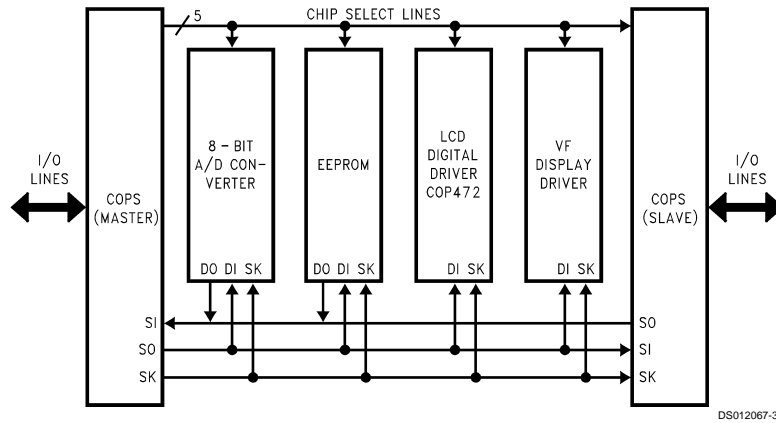

DS012067-38

FIGURE 39. MICROWIRE/PLUS Application

TABLE 10. MICROWIRE/PLUS Master Mode Clock Selection

SL1	SL0	SK
0	0	$2 \times t_c$
0	1	$4 \times t_c$
1	x	$8 \times t_c$

Where t_c is the instruction cycle clock

MICROWIRE/PLUS Slave Mode Operation

In the MICROWIRE/PLUS Slave mode of operation the SK clock is generated by an external source. Setting the MSEL bit in the CNTRL register enables the SO and SK functions onto the G Port. The SK pin must be selected as an input and the SO pin is selected as an output pin by setting and resetting the appropriate bit in the Port G configuration register. Table 2 summarizes the settings required to enter the Slave mode of operation.

The user must set the BUSY flag immediately upon entering the Slave mode. This will ensure that all data bits sent by the Master will be shifted properly. After eight clock pulses the BUSY flag will be cleared and the sequence may be repeated.

Alternate SK Phase Operation

The device allows either the normal SK clock or an alternate phase SK clock to shift data in and out of the SIO register. In both the modes the SK is normally low. In the normal mode data is shifted in on the rising edge of the SK clock and the data is shifted out on the falling edge of the SK clock. The SIO register is shifted on each falling edge of the SK clock in the normal mode. In the alternate SK phase mode the SIO register is shifted on the rising edge of the SK clock.

A control flag, SKSEL, allows either the normal SK clock or the alternate SK clock to be selected. Resetting SKSEL causes the MICROWIRE/PLUS logic to be clocked from the normal SK signal. Setting the SKSEL flag selects the alternate SK clock. The SKSEL is mapped into the G6 configuration bit. The SKSEL flag will power up in the reset condition, selecting the normal SK signal.

TABLE 11. MICROWIRE/PLUS Mode Selection
This table assumes that the control flag MSEL is set.

G4 (SO) Config. Bit	G5 (SK) Config. Bit	G4 Fun.	G5 Fun.	Operation
1	1	SO	Int. SK	MICROWIRE/PLUS Master
0	1	TRI-STATE	Int. SK	MICROWIRE/PLUS Master
1	0	SO	Ext. SK	MICROWIRE/PLUS Slave
0	0	TRI-STATE	Ext. SK	MICROWIRE/PLUS Slave

Memory Map

All RAM, ports and registers (except A and PC) are mapped into data memory address space.

Address	Contents
00 to 2F	On-Chip RAM bytes (48 bytes)
30 to 7F	Unused RAM Address Space (Reads As All Ones)
80 to 9F	Unused RAM Address Space (Reads Undefined Data)
A0	PSCAL, PWM timer Prescaler Register
A1	RLON, PWM timer On-Time Register
A2	PWMCON, PWM Control Register
A3 to AF	Reserved
B0	TXD1, Transmit 1 Data
B1	TXD2, Transmit 2 Data
B2	TDLC, Transmit Data Length Code and Identifier Low
B3	TID, Transmit Identifier High
B4	RXD1, Receive Data 1
B5	RXD2, Receive Data 2
B6	RIDL, Receive Data Length Code
B7	RID, Receive Identify High
B8	CSCAL, CAN Prescaler
B9	CTIM, Bus Timing Register
BA	CBUS, Bus Control Register
BB	TCNTL, Transmit/Receive Control Register
BC	RTSTAT Receive/Transmit Status Register
BD	TEC, Transmit Error Count Register
BE	REC, Receive Error Count Register
BF	Reserved
C0 to C7	Reserved
C8	WKEDG, MIWU Edge Select Register
C9	WKEN, MIWU Enable Register
CA	WKPND, MIWU Pending Register
CB to CF	Reserved
D0	PORTLD, Port L Data Register
D1	PORTLC, Port L Configuration Register
D2	PORTLP, Port L Input Pins (Read Only)
D3	CMPSL, Comparator control register
D4	PORTGD, Port G Data Register
D5	PORTGC, Port G Configuration Register
D6	PORTGP, Port G Input Pins (Read Only)
D7 to DB	Reserved
DC	PORTD, Port D output register
DD to DF	Reserved for Port D
E0 to E5	Reserved
E6	T1RBLO, Timer T1 Autoload Register Lower Byte
E7	T1RBHI, Timer T1 Autoload Register Upper Byte
E8	ICNTRL, Interrupt Control Register
E9	SIOR, MICROWIRE/PLUS Shift Register

Address	Contents
EA	TMR1LO, Timer T1 Lower Byte
EB	TMR1HI, Timer T1 Upper Byte
EC	T1RALO, Timer T1 Autoload Register Lower Byte
ED	T1RAHI, Timer T1 Autoload Register T1RA Upper Byte
EE	CNTRL, Control Register
EF	PSW, Processor Status Word Register
F0 to FB	On-Chip RAM Mapped as Registers
FC	X Register
FD	SP Register
FE	B Register
FF	Reserved (Note 20)

Note 19: Reading memory locations 30–7F Hex will return all ones. Reading other unused memory locations will return undefined data.

Note 20: In devices with more than 128 bytes of RAM, location 0FF is used as the Segment register to switch between different Segments of RAM memory. In this device location 0FF can be used as a general purpose, on-chip RAM mapped register. However, the user is advised that caution should be taken in porting software utilizing this memory location to a chip with more than 128 bytes of RAM.

Addressing Modes

There are ten addressing modes, six for operand addressing and four for transfer of control.

OPERAND ADDRESSING MODES

Register Indirect

This is the “normal” addressing mode. The operand is the data memory addressed by the B pointer or X pointer.

Register Indirect (with auto post Increment or decrement of pointer)

This addressing mode is used with the LD and X instructions. The operand is the data memory addressed by the B pointer or X pointer. This is a register indirect mode that automatically post increments or decrements the B or X register after executing the instruction.

Direct

The instruction contains an 8-bit address field that directly points to the data memory for the operand.

Immediate

The instruction contains an 8-bit immediate field as the operand.

Short Immediate

This addressing mode is used with the Load B Immediate instruction. The instruction contains a 4-bit immediate field as the operand.

Indirect

This addressing mode is used with the LAID instruction. The contents of the accumulator are used as a partial address (lower 8 bits of PC) for accessing a data operand from the program memory.

Addressing Modes (Continued)

TRANSFER OF CONTROL ADDRESSING MODES

Relative

This mode is used for the JP instruction, with the instruction field being added to the program counter to get the new program location. JP has a range from -31 to +32 to allow a 1-byte relative jump (JP + 1 is implemented by a NOP instruction). There are no "pages" when using JP, since all 15 bits of PC are used.

Absolute

This mode is used with the JMP and JSR instructions, with the instruction field of 12 bits replacing the lower 12 bits of the program counter (PC). This allows jumping to any location in the current 4k program memory segment.

Absolute Long

This mode is used with the JMPL and JSRL instructions, with the instruction field of 15 bits replacing the entire 15 bits of the program counter (PC). This allows jumping to any location up to 32k in the program memory space.

Indirect

This mode is used with the JID instruction. The contents of the accumulator are used as a partial address (lower 8 bits of PC) for accessing a location in the program memory. The contents of this program memory location serve as a partial address (lower 8 bits of PC) for the jump to the next instruction.

Note: The VIS is a special case of the Indirect Transfer of Control addressing mode, where the double byte vector associated with the interrupt is transferred from adjacent addresses in the program memory into the program counter (PC) in order to jump to the associated interrupt service routine.

Instruction Set

Register and Symbol Definition

Registers	
A	8-Bit Accumulator Register
B	8-Bit Address Register
X	8-Bit Address Register
SP	8-Bit Stack Pointer Register
PC	15-Bit Program Counter Register
PU	Upper 7 Bits of PC
PL	Lower 8 Bits of PC
C	1-Bit of PSW Register for Carry
HC	1-Bit of PSW Register for Half Carry
GIE	1-Bit of PSW Register for Global Interrupt Enable
VU	Interrupt Vector Upper Byte
VL	Interrupt Vector Lower Byte

Symbols	
[B]	Memory Indirectly Addressed by B Register
[X]	Memory Indirectly Addressed by X Register
MD	Direct Addressed Memory
Mem	Direct Addressed Memory or [B]
Meml	Direct Addressed Memory or [B] or Immediate Data
Imm	8-Bit Immediate Data
Reg	Register Memory: Addresses F0 to FF (Includes B, X and SP)
Bit	Bit Number (0 to 7)
←	Loaded with
↔	Exchanged with

Instruction Set (Continued)

INSTRUCTION SET

ADD	A,MemI	ADD	$A \leftarrow A + MemI$
ADC	A,MemI	ADD with Carry	$A \leftarrow A + MemI + C$, $C \leftarrow Carry$, $HC \leftarrow Half\ Carry$
SUBC	A,MemI	Subtract with Carry	$A \leftarrow A - MemI + C$, $C \leftarrow Carry$, $HC \leftarrow Half\ Carry$
AND	A,MemI	Logical AND	$A \leftarrow A \text{ and } \overline{MemI}$
ANDSZ	A,Imm	Logical AND Immed., Skip if Zero	Skip next if $(A \text{ and } Imm) = 0$
OR	A,MemI	Logical OR	$A \leftarrow A \text{ or } MemI$
XOR	A,MemI	Logical EXclusive OR	$A \leftarrow A \text{ xor } MemI$
IFEQ	MD,Imm	IF Equal	Compare MD and Imm, Do next if $MD = Imm$
IFEQ	A,MemI	IF Equal	Compare A and MemI, Do next if $A = MemI$
IFNE	A,MemI	IF Not Equal	Compare A and MemI, Do next if $A \neq MemI$
IFGT	A,MemI	IF Greater Than	Compare A and MemI, Do next if $A > MemI$
IFBNE	#	IF B Not Equal	Do next if lower 4 bits of $B \neq Imm$
DRSZ	Reg	Decrement Reg., Skip if Zero	$Reg \leftarrow Reg - 1$, Skip if $Reg = 0$
SBIT	#,Mem	Set BIT	1 to bit, Mem (bit = 0 to 7 immediate)
RBIT	#,Mem	Reset BIT	0 to bit, Mem
IFBIT	#,Mem	IF BIT	If bit in A or Mem is true do next instruction
RPND		Reset PeNDing Flag	Reset Software Interrupt Pending Flag
X	A,Mem	EXchange A with Memory	$A \leftrightarrow Mem$
X	A,[X]	EXchange A with Memory [X]	$A \leftrightarrow [X]$
LD	A,MemI	LoaD A with Memory	$A \leftarrow MemI$
LD	A,[X]	LoaD A with Memory [X]	$A \leftarrow [X]$
LD	B,Imm	LoaD B with Immed.	$B \leftarrow Imm$
LD	Mem,Imm	LoaD Memory Immed.	$Mem \leftarrow Imm$
LD	Reg,Imm	LoaD Register Memory Immed.	$Reg \leftarrow Imm$
X	A, [B±]	EXchange A with Memory [B]	$A \leftrightarrow [B]$, $(B \leftarrow B \pm 1)$
X	A, [X±]	EXchange A with Memory [X]	$A \leftrightarrow [X]$, $(X \leftarrow X \pm 1)$
LD	A, [B±]	LoaD A with Memory [B]	$A \leftarrow [B]$, $(B \leftarrow B \pm 1)$
LD	A, [X±]	LoaD A with Memory [X]	$A \leftarrow [X]$, $(X \leftarrow X \pm 1)$
LD	[B±],Imm	LoaD Memory [B] Immed.	$[B] \leftarrow Imm$, $(B \leftarrow B \pm 1)$
CLR	A	CLeaR A	$A \leftarrow 0$
INC	A	INCrement A	$A \leftarrow A + 1$
DEC	A	DECrementA	$A \leftarrow A - 1$
LAID		Load A InDirect from ROM	$A \leftarrow ROM(PU,A)$
DCOR	A	Decimal CORrect A	$A \leftarrow BCD \text{ correction of } A \text{ (follows ADC, SUBC)}$
RRC	A	Rotate A Right thru C	$C \rightarrow A7 \rightarrow \dots \rightarrow A0 \rightarrow C$
RLC	A	Rotate A Left thru C	$C \leftarrow A7 \leftarrow \dots \leftarrow A0 \leftarrow C$
SWAP	A	SWAP nibbles of A	$A7 \dots A4 \leftrightarrow A3 \dots A0$
SC		Set C	$C \leftarrow 1$, $HC \leftarrow 1$
RC		Reset C	$C \leftarrow 0$, $HC \leftarrow 0$
IFC		IF C	If C is true, do next instruction
IFNC		IF Not C	If C is not true, do next instruction
POP	A	POP the stack into A	$SP \leftarrow SP + 1$, $A \leftarrow [SP]$
PUSH	A	PUSH A onto the stack	$[SP] \leftarrow A$, $SP \leftarrow SP - 1$
VIS		Vector to Interrupt Service Routine	$PU \leftarrow [VU]$, $PL \leftarrow [VL]$
JMPL	Addr.	Jump absolute Long	$PC \leftarrow ii$ (ii = 15 bits, 0k to 32k)
JMP	Addr.	Jump absolute	$PC9 \dots 0 \leftarrow i$ (i = 12 bits)
JP	Disp.	Jump relative short	$PC \leftarrow PC + r$ (r is -31 to +32, except 1)

Instruction Set (Continued)

JSRL	Addr.	Jump SubRoutine Long	$[SP] \leftarrow PL, [SP-1] \leftarrow PU, SP-2, PC \leftarrow ii$
JSR	Addr.	Jump SubRoutine	$[SP] \leftarrow PL, [SP-1] \leftarrow PU, SP-2, PC9...0 \leftarrow i$
JID		Jump InDirect	$PL \leftarrow ROM(PU, A)$
RET		RETurn from subroutine	$SP + 2, PL \leftarrow [SP], PU \leftarrow [SP-1]$
RETSK		RETurn and SKip	$SP + 2, PL \leftarrow [SP], PU \leftarrow [SP-1]$
RETI		RETurn from Interrupt	$SP + 2, PL \leftarrow [SP], PU \leftarrow [SP-1], GIE \leftarrow 1$
INTR		Generate an Interrupt	$[SP] \leftarrow PL, [SP-1] \leftarrow PU, SP-2, PC \leftarrow 0FF$
NOP		No OPeration	$PC \leftarrow PC + 1$

Instruction Execution Time

Most instructions are single byte (with immediate addressing mode instructions taking two bytes).

Most single byte instructions take one cycle time to execute.

Skipped instructions require x number of cycles to be skipped, where x equals the number of bytes in the skipped instruction opcode.

See the BYTES and CYCLES per INSTRUCTION table for details.

Bytes and Cycles per Instruction

The following table shows the number of bytes and cycles for each instruction in the format of byte/cycle.

Arithmetic and Logic Instructions

	[B]	Direct	Immed.
ADD	1/1	3/4	2/2
ADC	1/1	3/4	2/2
SUBC	1/1	3/4	2/2
AND	1/1	3/4	2/2
OR	1/1	3/4	2/2
XOR	1/1	3/4	2/2
IFEQ	1/1	3/4	2/2
IFGT	1/1	3/4	2/2
IFBNE	1/1		
DRSZ		1/3	
SBIT	1/1	3/4	
RBIT	1/1	3/4	
IFBIT	1/1	3/4	

RPND	1/1
------	-----

Instructions Using A and C

CLRA	1/1
INCA	1/1
DECA	1/1
LAID	1/3
DCORA	1/1
RRCA	1/1
RLCA	1/1
SWAPA	1/1
SC	1/1
RC	1/1
IFC	1/1
IFNC	1/1
PUSHA	1/3
POPA	1/3
ANDSZ	2/2

Transfer of Control Instructions

JMPL	3/4
JMP	2/3
JP	1/3
JSRL	3/5
JSR	2/5
JID	1/3
VIS	1/5
RET	1/5
RETSK	1/5
RETI	1/5
INTR	1/7
NOP	1/1

Memory Transfer Instructions

	Register Indirect		Direct	Immed.	Register Indirect Auto Incr. and Decr.		(IF B < 16) (IF B > 15)
	[B]	[X]			[B+, B-]	[X+, X-]	
X A, (Note 21)	1/1	1/3	2/3		1/2	1/3	
LD A, (Note 21)	1/1	1/3	2/3	2/2	1/2	1/3	
LD B, Imm				1/1			
LD B, Imm				2/3			
LD Mem, Imm	2/2		3/3		2/2		
LD Reg, Imm			2/3				
IFEQ MD, Imm			3/3				

Note 21: > Memory location addressed by B or X or directly.

Opcode Table

UPPER NIBBLE											LOWER NIBBLE																				
F	E	D	C	B	A	9	8	7	6	5	4	3	2	1	0	F	E	D	C	B	A	9	8	7	6	5	4	3	2	1	0
JP-15	JP-31	LD 0F0, #i	DRSZ 0F0	RRCA	RC	ADC A, #i	ADC A, A,[B]	IFBIT 0,[B]	ANDSZ A, #i	LD B, #0F	IFBNE 0	JSR x000-x0FF	JMP x000-x0FF	JP+17	INTR 0	JP-15	JP-31	LD 0F0, #i	DRSZ 0F0	RRCA	RC	ADC A, #i	ADC A, A,[B]	IFBIT 0,[B]	ANDSZ A, #i	LD B, #0F	IFBNE 0	JSR x000-x0FF	JMP x000-x0FF	JP+17	INTR 0
JP-14	JP-30	LD 0F1, #i	DRSZ 0F1	*	SC	SUBC A, #i	SUB A,[B]	IFBIT 1,[B]	*	LD B, #0E	IFBNE 1	JSR x100-x1FF	JMP x100-x1FF	JP+18	JP+2 1	JP-14	JP-30	LD 0F1, #i	DRSZ 0F1	*	SC	SUBC A, #i	SUB A,[B]	IFBIT 1,[B]	*	LD B, #0E	IFBNE 1	JSR x100-x1FF	JMP x100-x1FF	JP+18	JP+2 1
JP-13	JP-29	LD 0F2, #i	DRSZ 0F2	X A, [X+]	X A, [B+]	IFEQ A, #i	IFEQ A,[B]	IFBIT 2,[B]	*	LD B, #0D	IFBNE 2	JSR x200-x2FF	JMP x200-x2FF	JP+19	JP+3 2	JP-13	JP-29	LD 0F2, #i	DRSZ 0F2	X A, [X+]	X A, [B+]	IFEQ A, #i	IFEQ A,[B]	IFBIT 2,[B]	*	LD B, #0D	IFBNE 2	JSR x200-x2FF	JMP x200-x2FF	JP+19	JP+3 2
JP-12	JP-28	LD 0F3, #i	DRSZ 0F3	X A, [X-]	X A, [B-]	IFGT A, #i	IFGT A,[B]	IFBIT 3,[B]	*	LD B, #0C	IFBNE 3	JSR x300-x3FF	JMP x300-x3FF	JP+20	JP+4 3	JP-12	JP-28	LD 0F3, #i	DRSZ 0F3	X A, [X-]	X A, [B-]	IFGT A, #i	IFGT A,[B]	IFBIT 3,[B]	*	LD B, #0C	IFBNE 3	JSR x300-x3FF	JMP x300-x3FF	JP+20	JP+4 3
JP-11	JP-27	LD 0F4, #i	DRSZ 0F4	VIS	LAI	ADD A, #i	ADD A,[B]	IFBIT 4,[B]	CLRA	LD B, #0B	IFBNE 4	JSR x400-x4FF	JMP x400-x4FF	JP+21	JP+5 4	JP-11	JP-27	LD 0F4, #i	DRSZ 0F4	VIS	LAI	ADD A, #i	ADD A,[B]	IFBIT 4,[B]	CLRA	LD B, #0B	IFBNE 4	JSR x400-x4FF	JMP x400-x4FF	JP+21	JP+5 4
JP-10	JP-26	LD 0F5, #i	DRSZ 0F5	RPND	JID	AND A, #i	AND A,[B]	IFBIT 5,[B]	SWAPA	LD B, #0A	IFBNE 5	JSR x500-x5FF	JMP x500-x5FF	JP+22	JP+6 5	JP-10	JP-26	LD 0F5, #i	DRSZ 0F5	RPND	JID	AND A, #i	AND A,[B]	IFBIT 5,[B]	SWAPA	LD B, #0A	IFBNE 5	JSR x500-x5FF	JMP x500-x5FF	JP+22	JP+6 5
JP-9	JP-25	LD 0F6, #i	DRSZ 0F6	X A, [X]	X A, [B]	XOR A, #i	XOR A,[B]	IFBIT 6,[B]	DCORA	LD B, #09	IFBNE 6	JSR x600-x6FF	JMP x600-x6FF	JP+23	JP+7 6	JP-9	JP-25	LD 0F6, #i	DRSZ 0F6	X A, [X]	X A, [B]	XOR A, #i	XOR A,[B]	IFBIT 6,[B]	DCORA	LD B, #09	IFBNE 6	JSR x600-x6FF	JMP x600-x6FF	JP+23	JP+7 6
JP-8	JP-24	LD 0F7, #i	DRSZ 0F7	*	*	OR A, #i	OR A,[B]	IFBIT 7,[B]	PUSHA	LD B, #08	IFBNE 7	JSR x700-x7FF	JMP x700-x7FF	JP+24	JP+8 7	JP-8	JP-24	LD 0F7, #i	DRSZ 0F7	*	*	OR A, #i	OR A,[B]	IFBIT 7,[B]	PUSHA	LD B, #08	IFBNE 7	JSR x700-x7FF	JMP x700-x7FF	JP+24	JP+8 7
JP-7	JP-23	LD 0F8, #i	DRSZ 0F8	NOP	RLCA	LD A, #i	IFC	SBIT 0,[B]	RBIT 0,[B]	LD B, #07	IFBNE 8	JSR x800-x8FF	JMP x800-x8FF	JP+25	JP+9 8	JP-7	JP-23	LD 0F8, #i	DRSZ 0F8	NOP	RLCA	LD A, #i	IFC	SBIT 0,[B]	RBIT 0,[B]	LD B, #07	IFBNE 8	JSR x800-x8FF	JMP x800-x8FF	JP+25	JP+9 8
JP-6	JP-22	LD 0F9, #i	DRSZ 0F9	IFNE A, [B]	IFEQ Md, #i	IFNE A, #i	IFNC A,[B]	SBIT 1,[B]	RBIT 1,[B]	LD B, #06	IFBNE 9	JSR x900-x9FF	JMP x900-x9FF	JP+26	JP+10 9	JP-6	JP-22	LD 0F9, #i	DRSZ 0F9	IFNE A, [B]	IFEQ Md, #i	IFNE A, #i	IFNC A,[B]	SBIT 1,[B]	RBIT 1,[B]	LD B, #06	IFBNE 9	JSR x900-x9FF	JMP x900-x9FF	JP+26	JP+10 9
JP-5	JP-21	LD 0FA, #i	DRSZ 0FA	LD A, [X+]	LD A, [B+]	LD A, #i	INCA [B+], #i	SBIT 2,[B]	RBIT 2,[B]	LD B, #05	IFBNE 0A	JSR xA00-xAFF	JMP xA00-xAFF	JP+27	JP+11 A	JP-5	JP-21	LD 0FA, #i	DRSZ 0FA	LD A, [X+]	LD A, [B+]	LD A, #i	INCA [B+], #i	SBIT 2,[B]	RBIT 2,[B]	LD B, #05	IFBNE 0A	JSR xA00-xAFF	JMP xA00-xAFF	JP+27	JP+11 A
JP-4	JP-20	LD 0FB, #i	DRSZ 0FB	LD A, [X-]	LD A, [B-]	LD A, #i	DECA [B-], #i	SBIT 3,[B]	RBIT 3,[B]	LD B, #04	IFBNE 0B	JSR xB00-xBFF	JMP xB00-xBFF	JP+28	JP+12 B	JP-4	JP-20	LD 0FB, #i	DRSZ 0FB	LD A, [X-]	LD A, [B-]	LD A, #i	DECA [B-], #i	SBIT 3,[B]	RBIT 3,[B]	LD B, #04	IFBNE 0B	JSR xB00-xBFF	JMP xB00-xBFF	JP+28	JP+12 B
JP-3	JP-19	LD 0FC, #i	DRSZ 0FC	LD Md, #i	JMPL X A, Md	X A, Md	POPA X A, Md	SBIT 4,[B]	RBIT 4,[B]	LD B, #03	IFBNE 0C	JSR xC00-xCFF	JMP xC00-xCFF	JP+29	JP+13 C	JP-3	JP-19	LD 0FC, #i	DRSZ 0FC	LD Md, #i	JMPL X A, Md	X A, Md	POPA X A, Md	SBIT 4,[B]	RBIT 4,[B]	LD B, #03	IFBNE 0C	JSR xC00-xCFF	JMP xC00-xCFF	JP+29	JP+13 C
JP-2	JP-18	LD 0FD, #i	DRSZ 0FD	DIR	JSRL A, Md	LD A, Md	RETSK A, Md	SBIT 5,[B]	RBIT 5,[B]	LD B, #02	IFBNE 0D	JSR xD00-xDFF	JMP xD00-xDFF	JP+30	JP+14 D	JP-2	JP-18	LD 0FD, #i	DRSZ 0FD	DIR	JSRL A, Md	LD A, Md	RETSK A, Md	SBIT 5,[B]	RBIT 5,[B]	LD B, #02	IFBNE 0D	JSR xD00-xDFF	JMP xD00-xDFF	JP+30	JP+14 D
JP-1	JP-17	LD 0FE, #i	DRSZ 0FE	LD A, [X]	LD A, [B]	LD A, #i	RET [B], #i	SBIT 6,[B]	RBIT 6,[B]	LD B, #01	IFBNE 0E	JSR xE00-xEFF	JMP xE00-xEFF	JP+31	JP+15 E	JP-1	JP-17	LD 0FE, #i	DRSZ 0FE	LD A, [X]	LD A, [B]	LD A, #i	RET [B], #i	SBIT 6,[B]	RBIT 6,[B]	LD B, #01	IFBNE 0E	JSR xE00-xEFF	JMP xE00-xEFF	JP+31	JP+15 E
JP-0	JP-16	LD 0FF, #i	DRSZ 0FF	*	*	LD B, #i	RETI LD B, #i	SBIT 7,[B]	RBIT 7,[B]	LD B, #00	IFBNE 0F	JSR xF00-xFFF	JMP xF00-xFFF	JP+32	JP+16 F	JP-0	JP-16	LD 0FF, #i	DRSZ 0FF	*	*	LD B, #i	RETI LD B, #i	SBIT 7,[B]	RBIT 7,[B]	LD B, #00	IFBNE 0F	JSR xF00-xFFF	JMP xF00-xFFF	JP+32	JP+16 F

where,
 i is the immediate data
 Md is a directly addressed memory location
 * is an unused opcode
 The opcode 60 Hex is also the opcode for IFBIT #i,A

Mask Options

The COP684BC and COP884BC mask programmable options are shown below. The options are programmed at the same time as the ROM pattern submission.

OPTION 1: CLOCK CONFIGURATION

- =1 Crystal Oscillator (CKI/10)
G7 (CKO) is clock generator output to crystal/resonator
CKI is the clock input

OPTION 2: HALT

- =1 Enable HALT mode
- =2 Disable HALT mode

OPTION 3: BOND OUT

- =1 28-Pin SO
- =2 20-Pin SO

OPTION 4: ON-CHIP POWER-ON RESET

- =1 Enable ON-CHIP POWER-ON RESET
- =2 Disable ON-CHIP POWER-ON RESET

The chip can be driven by a clock input on the CKI input pin which can be between DC and 10 MHz provided G7/CKO is driven with the inverse signal. The CKI input frequency is divided down by 10 to produce the instruction cycle clock ($1/t_c$).

Development Tools Support

OVERVIEW

National is engaged with an international community of independent 3rd party vendors who provide hardware and software development tool support. Through National's interaction and guidance, these tools cooperate to form a choice of solutions that fits each developer's needs.

This section provides a summary of the tool and development kits currently available. Up-to-date information, selection guides, free tools, demos, updates, and purchase information can be obtained at our web site at www.national.com/cop8.

SUMMARY OF TOOLS

COP8 Evaluation Tools

- **COP8-NSEVAL:** Free Software Evaluation package for Windows. A fully integrated evaluation environment for COP8, including versions of WCOP8 IDE (Integrated Development Environment), COP8-NSASM, COP8-MLSIM, COP8C, DriveWay™ COP8, Manuals, and other COP8 information.
- **COP8-MLSIM:** Free Instruction Level Simulator tool for Windows. For testing and debugging software instructions only (No I/O or interrupt support).
- **COP8-EPU:** Very Low cost COP8 Evaluation & Programming Unit. Windows based evaluation and hardware-simulation tool, with COP8 device programmer and erasable samples. Includes COP8-NSDEV, DriveWay COP8 Demo, MetaLink Debugger, I/O cables and power supply.
- **COP8-EVAL-ICUxx:** Very Low cost evaluation and design test board for COP8ACC and COP8SGx Families, from ICU. Real-time environment with add-on A/D, D/A, and EEPROM. Includes software routines and reference designs.

- **Manuals, Applications Notes, Literature:** Available free from our web site at: www.national.com/cop8.

COP8 Integrated Software/Hardware Design Development Kits

- **COP8-EPU:** Very Low cost Evaluation & Programming Unit. Windows based development and hardware-simulation tool for COPSx/xG families, with COP8 device programmer and samples. Includes COP8-NSDEV, DriveWay COP8 Demo, MetaLink Debugger, cables and power supply.
- **COP8-DM:** Moderate cost Debug Module from MetaLink. A Windows based, real-time in-circuit emulation tool with COP8 device programmer. Includes COP8-NSDEV, DriveWay COP8 Demo, MetaLink Debugger, power supply, emulation cables and adapters.

COP8 Development Languages and Environments

- **COP8-NSASM:** Free COP8 Assembler v5 for Win32. Macro assembler, linker, and librarian for COP8 software development. Supports all COP8 devices. (DOS/Win16 v4.10.2 available with limited support). (Compatible with WCOP8 IDE, COP8C, and DriveWay COP8).
- **COP8-NSDEV:** Very low cost Software Development Package for Windows. An integrated development environment for COP8, including WCOP8 IDE, COP8-NSASM, COP8-MLSIM.
- **COP8C:** Moderately priced C Cross-Compiler and Code Development System from Byte Craft (no code limit). Includes BCLIDE (Byte Craft Limited Integrated Development Environment) for Win32, editor, optimizing C Cross-Compiler, macro cross assembler, BC-Linker, and MetaLink tools support. (DOS/SUN versions available; Compiler is installable under WCOP8 IDE; Compatible with DriveWay COP8).
- **EW COP8-KS:** Very Low cost ANSI C-Compiler and Embedded Workbench from IAR (Kickstart version: COP8Sx/Fx only with 2k code limit; No FP). A fully integrated Win32 IDE, ANSI C-Compiler, macro assembler, editor, linker, Librarian, C-Spy simulator/debugger, PLUS MetaLink EPU/DM emulator support.
- **EW COP8-AS:** Moderately priced COP8 Assembler and Embedded Workbench from IAR (no code limit). A fully integrated Win32 IDE, macro assembler, editor, linker, librarian, and C-Spy high-level simulator/debugger with I/O and interrupts support. (Upgradeable with optional C-Compiler and/or MetaLink Debugger/Emulator support).
- **EW COP8-BL:** Moderately priced ANSI C-Compiler and Embedded Workbench from IAR (Baseline version: All COP8 devices; 4k code limit; no FP). A fully integrated Win32 IDE, ANSI C-Compiler, macro assembler, editor, linker, librarian, and C-Spy high-level simulator/debugger. (Upgradeable; CWCOP8-M MetaLink tools interface support optional).
- **EW COP8:** Full featured ANSI C-Compiler and Embedded Workbench for Windows from IAR (no code limit). A fully integrated Win32 IDE, ANSI C-Compiler, macro assembler, editor, linker, librarian, and C-Spy high-level simulator/debugger. (CWCOP8-M MetaLink tools interface support optional).

Development Tools Support

(Continued)

- **EWCOP8-M:** Full featured ANSI C-Compiler and Embedded Workbench for Windows from IAR (no code limit). A fully integrated Win32 IDE, ANSI C-Compiler, macro assembler, editor, linker, librarian, C-Spy high-level simulator/debugger, PLUS MetaLink debugger/hardware interface (CWCOP8-M).

COP8 Productivity Enhancement Tools

- **WCOP8 IDE:** Very Low cost IDE (Integrated Development Environment) from KKD. Supports COP8C, COP8-NSASM, COP8-MLSIM, DriveWay COP8, and MetaLink debugger under a common Windows Project Management environment. Code development, debug, and emulation tools can be launched from the project window framework.
- **DriveWay-COP8:** Low cost COP8 Peripherals Code Generation tool from Aisys Corporation. Automatically generates tested and documented C or Assembly source code modules containing I/O drivers and interrupt handlers for each on-chip peripheral. Application specific code can be inserted for customization using the integrated editor. (Compatible with COP8-NSASM, COP8C, and WCOP8 IDE.)
- **COP8-UTILS:** Free set of COP8 assembly code examples, device drivers, and utilities to speed up code development.

- **COP8-MLSIM:** Free Instruction Level Simulator tool for Windows. For testing and debugging software instructions only (No I/O or interrupt support).

COP8 Real-Time Emulation Tools

- **COP8-DM:** MetaLink Debug Module. A moderately priced real-time in-circuit emulation tool, with COP8 device programmer. Includes COP8-NSDEV, DriveWay COP8 Demo, MetaLink Debugger, power supply, emulation cables and adapters.
- **IM-COP8:** MetaLink iceMASTER®. A full featured, real-time in-circuit emulator for COP8 devices. Includes MetaLink Windows Debugger, and power supply. Package-specific probes and surface mount adaptors are ordered separately.

COP8 Device Programmer Support

- MetaLink's EPU and Debug Module include development device programming capability for COP8 devices.
- Third-party programmers and automatic handling equipment cover needs from engineering prototype and pilot production, to full production environments.
- Factory programming available for high-volume requirements.

TOOLS ORDERING NUMBERS FOR THE COP884BC/COP8885BC FAMILY DEVICES

Vendor	Tools	Order Number	Cost	Notes
National	COP8-NSEVAL	COP8-NSEVAL	Free	Web site download
	COP8-NSASM	COP8-NSASM	Free	Included in EPU and DM. Web site download
	COP8-MLSIM	COP8-MLSIM	Free	Included in EPU and DM. Web site download
	COP8-NSDEV	COP8-NSDEV	VL	Included in EPU and DM. Order CD from website
	COP8-EPU	Not available for this device		
	COP8-DM	Contact MetaLink		
	Development Devices	COP87L84BC	VL	16k OTP devices. No windowed devices.
	IM-COP8	Contact MetaLink		
MetaLink	COP8-EPU	Not available for this device		
	COP8-DM	DM4-COP8-888BC (10 MHz), plus PS-10, plus DM-COP8/xxx (ie. 28D)	M	Included p/s (PS-10), target cable of choice (i.e. DM-COP8/28D), 16/20/28/40 DIP/SO and 44 PLCC programming sockets
	DM Target Adapters	MHW-CONV39	L	DM target converters for 28SO
	IM-COP8	IM-COP8-AD-464 (-220) (10 MHz maximum)	H	Base unit 10 MHz; -220 = 220V; add probe card (required) and target adapter (if needed); included software and manuals
	IM-Probe Card	PC-888BC28D5-AD-10	M	10 MHz 28 DIP probe card; 2.5V to 6.0V
	IM Probe Target Adapter	MHW-SOIC28	L	28 pin SOIC adapter for probe card
ICU	COP8-EVAL	Not available for this device		
KKD	WCOP8-IDE	WCOP8-IDE	VL	Included in EPU and DM
IAR	EWCOP8-xx	See summary above	L - H	Included all software and manuals
Byte Craft	COP8C	COP8C	M	Included all software and manuals
Aisys	DriveWay COP8	DriveWay COP8	L	Included all software and manuals

Development Tools Support (Continued)

OTP Programmers	Contact vendor	L - H	For approved programmer listings and vendor information, go to our OTP support page at: www.national.com/cop8
Cost: Free; VL =< \$100; L = \$100 - \$300; M = \$300 - \$1k; H = \$1k - \$3k; VH = \$3k - \$5k			

WHERE TO GET TOOLS

Tools are ordered directly from the following vendors. Please go to the vendor's web site for current listings of distributors.

Vendor	Home Office	Electronic Sites	Other Main Offices
Aisys	U.S.A.: Santa Clara, CA 1-408-327-8820 fax: 1-408-327-8830	www.aisysinc.com info@aisysinc.com	Distributors
Byte Craft	U.S.A. 1-519-888-6911 fax: 1-519-746-6751	www.bytecraft.com info@bytecraft.com	Distributors
IAR	Sweden: Uppsala +46 18 16 78 00 fax: +46 18 16 78 38	www.iar.se info@iar.se info@iar.com info@iarsys.co.uk info@iar.de	U.S.A.: San Francisco 1-415-765-5500 fax: 1-415-765-5503 U.K.: London +44 171 924 33 34 fax: +44 171 924 53 41 Germany: Munich +49 89 470 6022 fax: +49 89 470 956
ICU	Sweden: Polygonvaegen +46 8 630 11 20 fax: +46 8 630 11 70	www.icu.se support@icu.se support@icu.ch	Switzerland: Hoehe +41 34 497 28 20 fax: +41 34 497 28 21
KKD	Denmark:	www.kkd.dk	
MetaLink	U.S.A.: Chandler, AZ 1-800-638-2423 fax: 1-602-926-1198	www.metaice.com sales@metaice.com support@metaice.com bbs: 1-602-962-0013 www.metalink.de	Germany: Kirchseeon 80-91-5696-0 fax: 80-91-2386 islanger@metalink.de Distributors Worldwide
National	U.S.A.: Santa Clara, CA 1-800-272-9959 fax: 1-800-737-7018	www.national.com/cop8 support@nsc.com europe.support@nsc.com	Europe: +49 (0) 180 530 8585 fax: +49 (0) 180 530 8586 Distributors Worldwide

The following companies have approved COP8 programmers in a variety of configurations. Contact your local office or distributor. You can link to their web sites and get the latest listing of approved programmers from National's COP8 OTP Support page at: www.national.com/cop8.

Advantech; Advin; BP Microsystems; Data I/O; Hi-Lo Systems; ICE Technology; Lloyd Research; Logical Devices; MQP; Needhams; Phytion; SMS; Stag Programmers; System General; Tribal Microsystems; Xeltek.

Customer Support

Complete product information and technical support is available from National's customer response centers, and from our on-line COP8 customer support sites.

Physical Dimensions inches (millimeters) unless otherwise noted

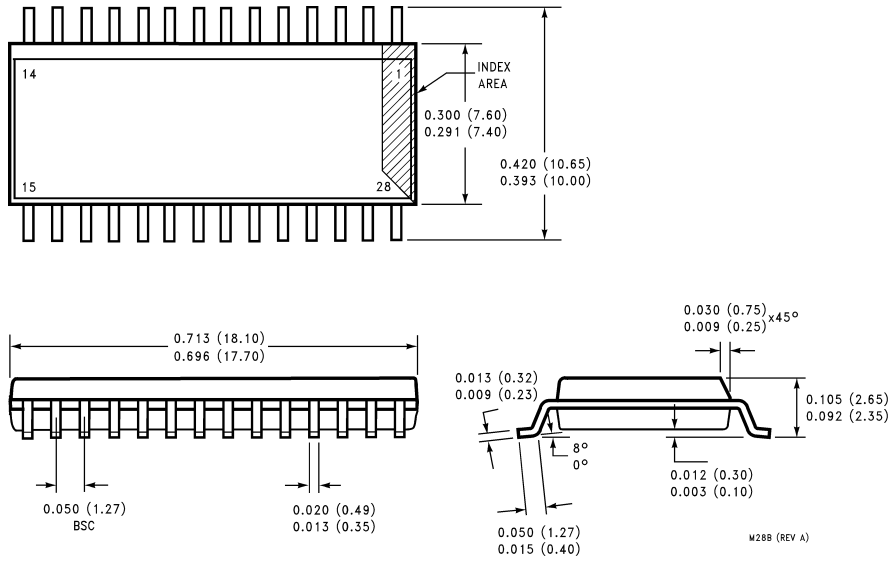

Order Number COP884BC-xxx/M or COP684BC-xxx/M
NS Package Number M28B

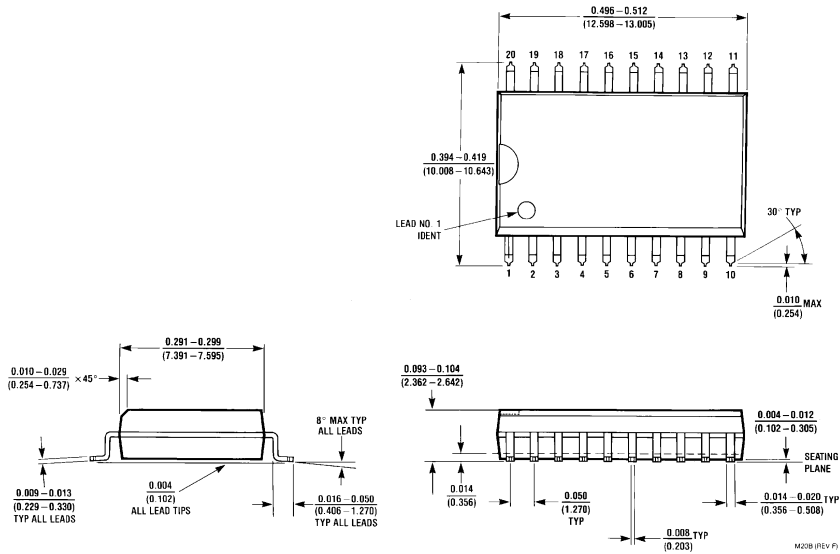

Order Number COP885BC-xxx/M or COP685BC-xxx/M
NS Package Number M20B

Notes

LIFE SUPPORT POLICY

NATIONAL'S PRODUCTS ARE NOT AUTHORIZED FOR USE AS CRITICAL COMPONENTS IN LIFE SUPPORT DEVICES OR SYSTEMS WITHOUT THE EXPRESS WRITTEN APPROVAL OF THE PRESIDENT AND GENERAL COUNSEL OF NATIONAL SEMICONDUCTOR CORPORATION. As used herein:

1. Life support devices or systems are devices or systems which, (a) are intended for surgical implant into the body, or (b) support or sustain life, and whose failure to perform when properly used in accordance with instructions for use provided in the labeling, can be reasonably expected to result in a significant injury to the user.
2. A critical component is any component of a life support device or system whose failure to perform can be reasonably expected to cause the failure of the life support device or system, or to affect its safety or effectiveness.



National Semiconductor Corporation
Americas
Tel: 1-800-272-9959
Fax: 1-800-737-7018
Email: support@nsc.com

www.national.com

National Semiconductor Europe
Fax: +49 (0) 1 80-530 85 86
Email: europe.support@nsc.com
Deutsch Tel: +49 (0) 1 80-530 85 85
English Tel: +49 (0) 1 80-532 78 32
Français Tel: +49 (0) 1 80-532 93 58
Italiano Tel: +49 (0) 1 80-534 16 80

National Semiconductor Asia Pacific Customer Response Group
Tel: 65-2544466
Fax: 65-2504466
Email: sea.support@nsc.com

National Semiconductor Japan Ltd.
Tel: 81-3-5639-7560
Fax: 81-3-5639-7507