

# COP888EK

## 8-Bit CMOS ROM Based Microcontrollers with 8k Memory, Comparator, and Single-slope A/D Capability

### General Description

The COP888EK ROM based microcontrollers are highly integrated COP8™ Feature core devices with 8k memory and advanced features including a Multi-Input Comparator and Single-slope A/D capability. These single-chip CMOS devices are suited for applications requiring a full featured, low EMI controller with an analog comparator, current source, and voltage reference. The COP87L88EK/RK Family devices are pin and software compatible (different  $V_{CC}$  range) 16k or 32k OTP (One Time Programmable) versions for pre-production, and for use with a range of COP8 software and hardware development tools.

Family features include an 8-bit memory mapped architecture, 10 MHz CKI with 1 $\mu$ s instruction cycle, three multi-function 16-bit timer/counters with PWM, MICROWIRE/PLUS™ serial I/O, one analog comparator with seven input multiplexor, an analog current source and  $V_{CC}$  reference, two power saving HALT/IDLE modes, idle timer, MIWU, high current outputs, software selectable I/O options, WATCHDOG™ timer and Clock Monitor, Low EMI 2.5V to 6.0V operation and 28/40/44 pin packages.

Devices included in this datasheet are:

Device	Memory (bytes)	RAM (bytes)	I/O Pins	Packages	Temperature	Comments
COP684EK	8k ROM	256	24	28 DIP/SOIC	-55 to +125°C	4.5V - 5.5V
COP884EK	8k ROM	256	24	28 DIP/SOIC	-40 to +85°C	
COP984EK	8k ROM	256	24	28 DIP/SOIC	0 to +70°C	2.5V - 4.0V, EKH=4.0V - 6.0V
COP688EK	8k ROM	256	36/40	40 DIP, 44 PLCC	-55 to +125°C	4.5V - 5.5V
COP888EK	8k ROM	256	36/40	40 DIP, 44 PLCC	-40 to +85°C	
COP988EK	8k ROM	256	36/40	40 DIP, 44 PLCC	0 to +70°C	2.5V - 4.0V, EKH=4.0V - 6.0V

### Key Features

- Analog function block with
  - Analog comparator with seven input multiplexor
  - Constant current source and  $V_{CC}/2$  reference
- Three 16-bit timers, each with two 16-bit registers supporting:
  - Processor Independent PWM mode
  - External Event counter mode
  - Input Capture mode
- 8 kbytes of on-chip ROM
- 256 bytes of on-chip RAM

### Additional Peripheral Features

- Idle Timer
- Multi-Input Wake Up (MIWU) with optional interrupts (8)
- WATCHDOG and Clock Monitor logic
- MICROWIRE/PLUS serial I/O

### I/O Features

- Software selectable I/O options (TRI-STATE™ Output, Push-Pull Output, Weak Pull-Up Input, High Impedance Input)
- High current outputs
- Schmitt trigger inputs on Port G and L
- Packages: 44 PLCC with 40 I/O pins, 40 DIP with 36 I/O pins, and 28 DIP/SO with 24 I/O pins

### CPU/Instruction Set Feature

- 1  $\mu$ s instruction cycle time
- Twelve multi-source vectored interrupts servicing
  - External Interrupt with selectable edge
  - Idle Timer T0
  - Three Timers (Each with 2 interrupts)
  - MICROWIRE/PLUS
  - Multi-Input Wake Up
  - Software Trap
  - Default VIS (default interrupt)
- Versatile and easy to use instruction set
- 8-bit Stack Pointer (SP) — stack in RAM
- Two 8-bit Register Indirect Data Memory Pointers (B, X)

### Fully Static CMOS

- Single supply operation: 2.5V to 6.0V
- Temperature ranges: 0°C to +70°C, -40°C to +85°C, and -55°C to +125°C

COP8™, MICROWIRE/PLUS™, and WATCHDOG™ are trademarks of National Semiconductor Corporation.  
 TRI-STATE® is a registered trademark of National Semiconductor Corporation.  
 iceMASTER® is a registered trademark of MetaLink Corporation.

# Development Support

■ Real time emulation and full program debug offered by MetaLink Development System

■ Emulation and OTP devices

## Block Diagram

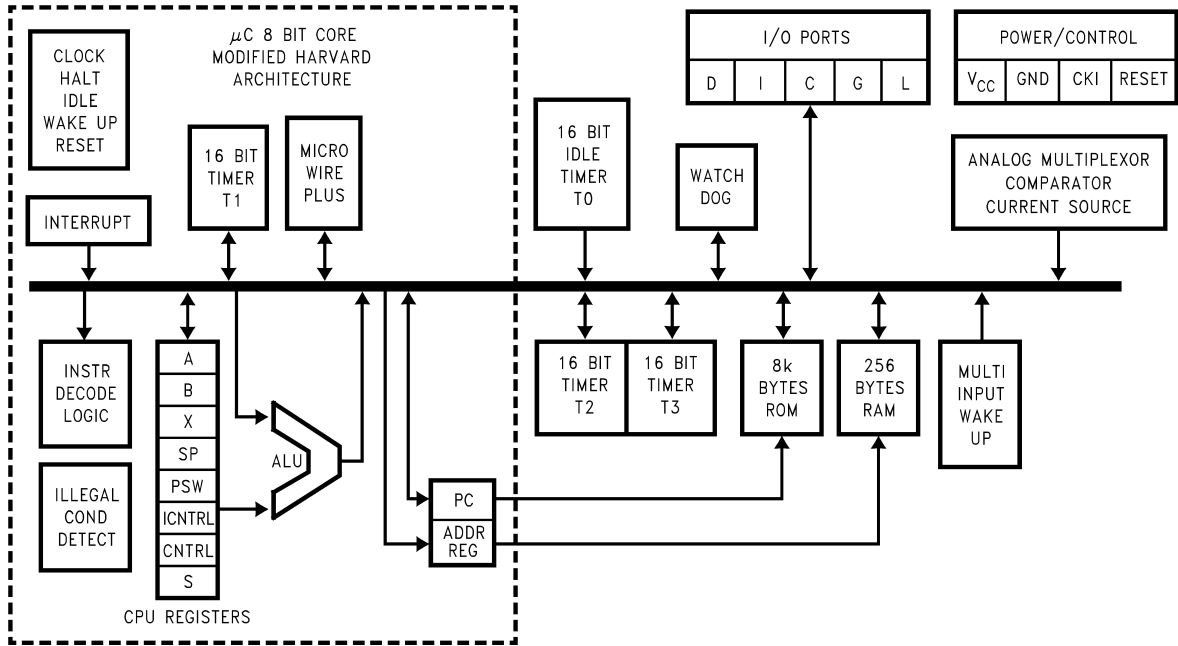
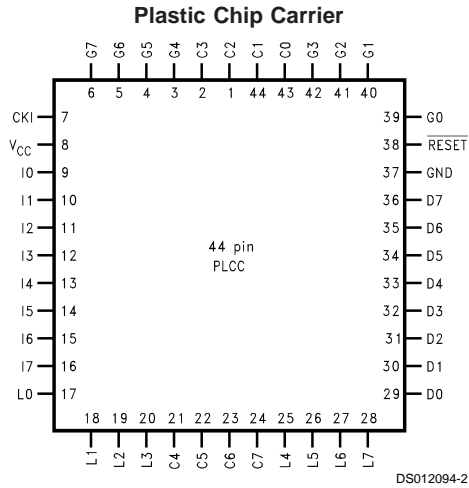

FIGURE 1. Block Diagram

DS012094-1

# Connection Diagrams



**Top View**

Order Number COP688EK-XXX/V, COP888EK-XXX/V,  
COP988EK-XXX/V or COP988EKH-XXX/V  
See NS Plastic Chip Package Number V44A

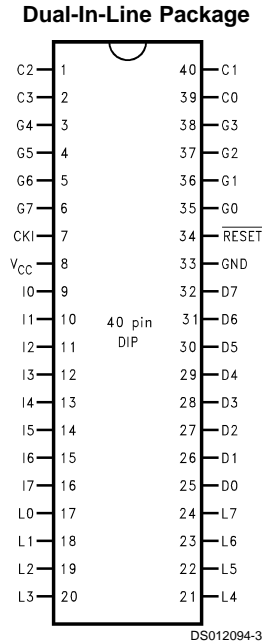

**Top View**

Order Number COP688EK-XXX/N, COP888EK-XXX/N,  
COP988EK-XXX/N or COP988EKH-XXX/N  
See NS Molded Package Number N40A

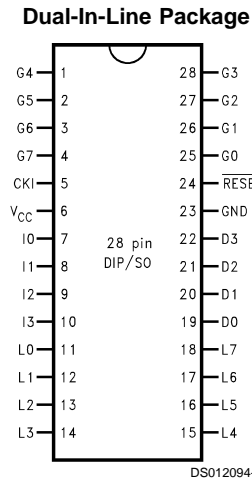

**Top View**

Order Number COP684EK-XXX/N, COP884EK-XXX/N, COP984EK-XXX/N or COP984EKH-XXX/N  
See NS Molded Package Number N28B  
Order Number COP684EK-XXX/WM, COP884EK-XXX/WM, COP984EK-XXX/WM or COP984EKH-XXX/WM  
See NS Molded Package Number M28B

**FIGURE 2. Connection Diagrams**

## Connection Diagrams (Continued)

### Pinouts for 28-, 40- and 44-Pin Packages

Port	Type	Alt. Fun	Alt. Fun	28-Pin Pack.	40-Pin Pack.	44-Pin Pack.
L0	I/O	MIWU		11	17	17
L1	I/O	MIWU		12	18	18
L2	I/O	MIWU		13	19	19
L3	I/O	MIWU		14	20	20
L4	I/O	MIWU	T2A	15	21	25
L5	I/O	MIWU	T2B	16	22	26
L6	I/O	MIWU	T3A	17	23	27
L7	I/O	MIWU	T3B	18	24	28
G0	I/O	INT		25	35	39
G1	WDOUT			26	36	40
G2	I/O	T1B		27	37	41
G3	I/O	T1A		28	38	42
G4	I/O	SO		1	3	3
G5	I/O	SK		2	4	4
G6	I	SI		3	5	5
G7	I/CKO	HALT Restart		4	6	6
D0	O			19	25	29
D1	O			20	26	30
D2	O			21	27	31
D3	O			22	28	32
I0	I	COMPIN1+		7	9	9
I1	I	COMPIN-/Current Source Out		8	10	10
I2	I	COMPIN0+		9	11	11
I3	I	COMPOUT/COMPIN2+		10	12	12
I4	I	COMPIN3+			13	13
I5	I	COMPIN4+			14	14
I6	I	COMPIN5+			15	15
I7	I	COMPOUT			16	16
D4	O				29	33
D5	O				30	34
D6	O				31	35
D7	O				32	36
C0	I/O				39	43
C1	I/O				40	44
C2	I/O				1	1
C3	I/O				2	2
C4	I/O					21
C5	I/O					22
C6	I/O					23
C7	I/O					24
V <sub>CC</sub>				6	8	8
GND				23	33	37
CKI				5	7	7
RESET				24	34	38

**Absolute Maximum Ratings** (Note 1)

If Military/Aerospace specified devices are required, please contact the National Semiconductor Sales Office/Distributors for availability and specifications.

Supply Voltage ( $V_{CC}$ ) 7V  
Voltage at Any Pin  $-0.3V$  to  $V_{CC} + 0.3V$

Total Current into  $V_{CC}$  Pin (Source) 100 mA  
Total Current out of GND Pin (Sink) 110 mA  
Storage Temperature Range  $-65^{\circ}C$  to  $+140^{\circ}C$

**Note 1:** Absolute maximum ratings indicate limits beyond which damage to the device may occur. DC and AC electrical specifications are not ensured when operating the device at absolute maximum ratings.

**DC Electrical Characteristics 98xEK:**

$0^{\circ}C \leq T_A \leq +70^{\circ}C$  unless otherwise specified

Parameter	Conditions	Min	Typ	Max	Units
Operating Voltage COP98XEK		2.5		4.0	V
COP98XEKH		4.0		6.0	V
Power Supply Ripple (Note 3)	Peak-to-Peak			$0.1 V_{CC}$	V
Supply Current (Note 4)					
CKI = 10 MHz	$V_{CC} = 6.0V, t_c = 1 \mu s$			10.0	mA
CKI = 4 MHz	$V_{CC} = 2.5V, t_c = 2.5 \mu s$			1.7	mA
HALT Current (Note 5)					
	$V_{CC} = 6.0V, CKI = 0 MHz$		<4	8	$\mu A$
	$V_{CC} = 4.0V, CKI = 0 MHz$		<3	4	$\mu A$
IDLE Current (Note 4)					
CKI = 10 MHz	$V_{CC} = 6.0V, t_c = 1 \mu s$		0.4	1.7	mA
CKI = 4 MHz	$V_{CC} = 2.5V, t_c = 2.5 \mu s$		0.2	0.5	mA
Input Levels ( $V_{IH}, V_{IL}$ )					
RESET					
Logic High		$0.8 V_{CC}$			V
Logic Low				$0.2 V_{CC}$	V
CKI, All Other Inputs					
Logic High		$0.7 V_{CC}$			V
Logic Low				$0.2 V_{CC}$	V
Hi-Z Input Leakage	$V_{CC} = 6.0V$	-1		+1	$\mu A$
Input Pullup Current	$V_{CC} = 6.0V, V_{IN} = 0V$	-40		-250	$\mu A$
G and L Port Input Hysteresis (Note 8)				$0.35 V_{CC}$	V
Output Current Levels					
D Outputs					
Source	$V_{CC} = 4.0V, V_{OH} = 3.3V$	-0.4			mA
	$V_{CC} = 2.5V, V_{OH} = 1.8V$	-0.2			mA
Sink	$V_{CC} = 4.0V, V_{OL} = 1V$	10			mA
	$V_{CC} = 2.5V, V_{OL} = 0.4V$	2.0			mA
All Others					
Source (Weak Pull-Up Mode)	$V_{CC} = 4.0V, V_{OH} = 2.7V$	-10		-110	$\mu A$
	$V_{CC} = 2.5V, V_{OH} = 1.8V$	-2.5		-33	$\mu A$
Source (Push-Pull Mode)	$V_{CC} = 4.0V, V_{OH} = 3.3V$	-0.4			mA
	$V_{CC} = 2.5V, V_{OH} = 1.8V$	-0.2			mA
Sink (Push-Pull Mode)	$V_{CC} = 4.0V, V_{OL} = 0.4V$	1.6			mA
	$V_{CC} = 2.5V, V_{OL} = 0.4V$	0.7			mA
TRI-STATE Leakage	$V_{CC} = 6.0V$	-1		+1	$\mu A$
Allowable Sink/Source Current per Pin (Note 8)					
D Outputs (Sink)				15	mA
All others				3	mA
Maximum Input Current without Latchup (Note 6)	Room Temp			$\pm 100$	mA
RAM Retention Voltage, $V_r$	500 ns Rise and Fall Time (Min)	2			V

**DC Electrical Characteristics 98xEK:** (Continued)0°C ≤ T<sub>A</sub> ≤ +70°C unless otherwise specified

Parameter	Conditions	Min	Typ	Max	Units
Input Capacitance				7	pF
Load Capacitance on D2				1000	pF

**AC Electrical Characteristics 98xEK:**0°C ≤ T<sub>A</sub> ≤ +70°C unless otherwise specified

Parameter	Conditions	Min	Typ	Max	Units
Instruction Cycle Time (t <sub>c</sub> )					
Crystal, Resonator,	4.0V ≤ V <sub>CC</sub> ≤ 6.0V	1.0		DC	μs
	2.5V ≤ V <sub>CC</sub> < 4.0V	2.5		DC	μs
R/C Oscillator	4.0V ≤ V <sub>CC</sub> ≤ 6.0V	3.0		DC	μs
	2.5V ≤ V <sub>CC</sub> < 4.0V	7.5		DC	μs
Inputs					
t <sub>SETUP</sub>	4.0V ≤ V <sub>CC</sub> ≤ 6.0V	200			ns
	2.5V ≤ V <sub>CC</sub> < 4.0V	500			ns
t <sub>HOLD</sub>	4.0V ≤ V <sub>CC</sub> ≤ 6.0V	60			ns
	2.5V ≤ V <sub>CC</sub> < 4.0V	150			ns
Output Propagation Delay (Note 7)	R <sub>L</sub> = 2.2k, C <sub>L</sub> = 100 pF				
t <sub>PD1</sub> , t <sub>PD0</sub>	4.0V ≤ V <sub>CC</sub> ≤ 6.0V			0.7	μs
SO, SK	2.5V ≤ V <sub>CC</sub> < 4.0V			1.75	μs
All Others	4.0V ≤ V <sub>CC</sub> ≤ 6.0V			1	μs
	2.5V ≤ V <sub>CC</sub> < 4.0V			2.5	μs
MICROWIRE™ Setup Time (t <sub>UWS</sub> ) (Note 7)	V <sub>CC</sub> ≥ 4.0V	20			ns
MICROWIRE Hold Time (t <sub>UWH</sub> ) (Note 7)	V <sub>CC</sub> ≥ 4.0V	56			ns
MICROWIRE Output Propagation Delay (t <sub>UPD</sub> )	V <sub>CC</sub> ≥ 4.0V			220	ns
Input Pulse Width (Note 8)					
Interrupt Input High Time		1.0			t <sub>c</sub>
Interrupt Input Low Time		1.0			t <sub>c</sub>
Timer 1, 2, 3 Input High Time		1.0			t <sub>c</sub>
Timer 1, 2, 3 Input Low Time		1.0			t <sub>c</sub>
Reset Pulse Width		1.0			μs

**Note 2:** t<sub>c</sub> = Instruction Cycle Time**Note 3:** Maximum rate of voltage change must be < 0.5 V/ms.**Note 4:** Supply and IDLE currents are measured with CKI driven with a square wave Oscillator, CKO driven 180° out of phase with CKI, inputs connected to V<sub>CC</sub> and outputs driven low but not connected to a load.**Note 5:** The HALT mode will stop CKI from oscillating in the RC and the Crystal configurations. Measurement of I<sub>DD</sub> HALT is done with device neither sourcing nor sinking current; with L, C, and G0–G5 programmed as low outputs and not driving a load; all outputs programmed low and not driving a load; all inputs tied to V<sub>CC</sub>; clock monitor and comparator disabled. Parameter refers to HALT mode entered via setting bit 7 of the G Port data register. Part will pull up CKI during HALT in crystal clock mode.**Note 6:** Pins G6 and RESET are designed with a high voltage input network. These pins allow input voltages > V<sub>CC</sub> and the pins will have sink current to V<sub>CC</sub> when biased at voltages > V<sub>CC</sub> (the pins do not have source current when biased at a voltage below V<sub>CC</sub>). The effective resistance to V<sub>CC</sub> is 750Ω (typical). These two pins will not latch up. The voltage at the pins must be limited to < 14V. **WARNING: Voltages in excess of 14V will cause damage to the pins. This warning excludes ESD transients.****Note 7:** The output propagation delay is referenced to the end of the instruction cycle where the output change occurs.**Note 8:** Parameter characterized but not tested.

**Absolute Maximum Ratings** (Note 9)

If Military/Aerospace specified devices are required, please contact the National Semiconductor Sales Office/Distributors for availability and specifications.

Supply Voltage ( $V_{CC}$ ) 7V  
Voltage at Any Pin  $-0.3V$  to  $V_{CC} + 0.3V$

Total Current into  $V_{CC}$  Pin (Source) 100 mA  
Total Current out of GND Pin (Sink) 110 mA  
Storage Temperature Range  $-65^{\circ}C$  to  $+140^{\circ}C$

**Note 9:** Absolute maximum ratings indicate limits beyond which damage to the device may occur. DC and AC electrical specifications are not ensured when operating the device at absolute maximum ratings.

**DC Electrical Characteristics 88xEK:**

$-40^{\circ}C \leq T_A \leq +85^{\circ}C$  unless otherwise specified

Parameter	Conditions	Min	Typ	Max	Units
Operating Voltage		2.5		6.0	V
Power Supply Ripple (Note 11)	Peak-to-Peak			$0.1 V_{CC}$	V
Supply Current (Note 12)					
CKI = 10 MHz	$V_{CC} = 6.0V, t_c = 1 \mu s$			10.0	mA
CKI = 4 MHz	$V_{CC} = 2.5V, t_c = 2.5 \mu s$			1.7	mA
HALT Current (Note 13)	$V_{CC} = 6.0V, CKI = 0$ MHz		<4	10	$\mu A$
IDLE Current (Note 12)					
CKI = 10 MHz	$V_{CC} = 6.0V, t_c = 1 \mu s$		0.4	1.7	mA
CKI = 4 MHz	$V_{CC} = 6.0V, t_c = 2.5 \mu s$		0.2	0.5	mA
Input Levels ( $V_{IH}, V_{IL}$ )					
RESET					
Logic High		$0.8 V_{CC}$			V
Logic Low				$0.2 V_{CC}$	V
CKI, All Other Inputs					
Logic High		$0.7 V_{CC}$			V
Logic Low				$0.2 V_{CC}$	V
Hi-Z Input Leakage	$V_{CC} = 6.0V$	-2		+2	$\mu A$
Input Pullup Current	$V_{CC} = 6.0V, V_{IN} = 0V$	-40		-250	$\mu A$
G and L Port Input Hysteresis (Note 16)				$0.35 V_{CC}$	V
Output Current Levels					
D Outputs					
Source	$V_{CC} = 4.0V, V_{OH} = 3.3V$	-0.4			mA
	$V_{CC} = 2.5V, V_{OH} = 1.8V$	-0.2			mA
Sink	$V_{CC} = 4.0V, V_{OL} = 1V$	10			mA
	$V_{CC} = 2.5V, V_{OL} = 0.4V$	2.0			mA
All Others					
Source (Weak Pull-Up Mode)	$V_{CC} = 4.0V, V_{OH} = 2.7V$	-10		-100	$\mu A$
	$V_{CC} = 2.5V, V_{OH} = 1.8V$	-2.5		-33	$\mu A$
Source (Push-Pull Mode)	$V_{CC} = 4.0V, V_{OH} = 3.3V$	-0.4			mA
	$V_{CC} = 2.5V, V_{OH} = 1.8V$	-0.2			mA
Sink (Push-Pull Mode)	$V_{CC} = 4.0V, V_{OL} = 0.4V$	1.6			mA
	$V_{CC} = 2.5V, V_{OL} = 0.4V$	0.7			mA
TRI-STATE Leakage	$V_{CC} = 6.0V$	-2		+2	$\mu A$
Allowable Sink/Source Current per Pin (Note 16)					
D Outputs (Sink)				15	mA
All others				3	mA
Maximum Input Current without Latchup (Note 14)	Room Temp			$\pm 100$	mA
RAM Retention Voltage, $V_r$	500 ns Rise and Fall Time (min)	2			V
Input Capacitance				7	pF

**DC Electrical Characteristics 88xEK:** (Continued)-40°C ≤ T<sub>A</sub> ≤ +85°C unless otherwise specified

Parameter	Conditions	Min	Typ	Max	Units
Load Capacitance on D2				1000	pF

**AC Electrical Characteristics 88xEK:**-40°C ≤ T<sub>A</sub> ≤ +85°C unless otherwise specified

Parameter	Conditions	Min	Typ	Max	Units
Instruction Cycle Time (t <sub>c</sub> )					
Crystal, Resonator,	4.0V ≤ V <sub>CC</sub> ≤ 6.0V	1.0		DC	μs
	2.5V ≤ V <sub>CC</sub> < 4.0V	2.5		DC	μs
R/C Oscillator	4.0V ≤ V <sub>CC</sub> ≤ 6.0V	3.0		DC	μs
	2.5V ≤ V <sub>CC</sub> < 4.0V	7.5		DC	μs
Inputs					
t <sub>SETUP</sub>	4.0V ≤ V <sub>CC</sub> ≤ 6.0V	200			ns
	2.5V ≤ V <sub>CC</sub> < 4.0V	500			ns
t <sub>HOLD</sub>	4.0V ≤ V <sub>CC</sub> ≤ 6.0V	60			ns
	2.5V ≤ V <sub>CC</sub> < 4.0V	150			ns
Output Propagation Delay (Note 15)	R <sub>L</sub> = 2.2k, C <sub>L</sub> = 100 pF				
t <sub>PD1</sub> , t <sub>PD0</sub>					
SO, SK	4.0V ≤ V <sub>CC</sub> ≤ 6.0V			0.7	μs
	2.5V ≤ V <sub>CC</sub> < 4.0V			1.75	μs
All Others	4.0V ≤ V <sub>CC</sub> ≤ 6.0V			1.0	μs
	2.5V ≤ V <sub>CC</sub> < 4.0V			2.5	μs
MICROWIRE Setup Time (t <sub>UWS</sub> ) (Note 15)		20			ns
MICROWIRE Hold Time (t <sub>UWH</sub> ) (Note 15)		56			ns
MICROWIRE Output Propagation Delay (t <sub>UPD</sub> )				220	ns
Input Pulse Width (Note 16)					
Interrupt Input High Time		1.0			t <sub>c</sub>
Interrupt Input Low Time		1.0			t <sub>c</sub>
Timer 1, 2, 3 Input High Time		1.0			t <sub>c</sub>
Timer 1, 2, 3 Input Low Time		1.0			t <sub>c</sub>
Reset Pulse Width		1.0			μs

**Note 10:** t<sub>c</sub> = Instruction Cycle Time**Note 11:** Maximum rate of voltage change must be < 0.5 V/ms.**Note 12:** Supply and IDLE currents are measured with CKI driven with a square wave Oscillator, CKO driven 180° out of phase with CKI, inputs connected to V<sub>CC</sub> and outputs driven low but not connected to a load.**Note 13:** The HALT mode will stop CKI from oscillating in the RC and the Crystal configurations. Measurement of I<sub>DD</sub> HALT is done with device neither sourcing nor sinking current; with L, C, G0, and G2–G5 programmed as low outputs and not driving a load; all outputs programmed low and not driving a load; all inputs tied to V<sub>CC</sub>; clock monitor and comparator disabled. Parameter refers to HALT mode entered via setting bit 7 of the G Port data register. Part will pull up CKI during HALT in crystal clock mode.**Note 14:** Pins G6 and  $\overline{\text{RESET}}$  are designed with a high voltage input network. These pins allow input voltages > V<sub>CC</sub> and the pins will have sink current to V<sub>CC</sub> when biased at voltages > V<sub>CC</sub> (the pins do not have source current when biased at a voltage below V<sub>CC</sub>). The effective resistance to V<sub>CC</sub> is 750Ω (typical). These two pins will not latch up. The voltage at the pins must be limited to < 14V. **WARNING: Voltages in excess of 14V will cause damage to the pins. This warning excludes ESD transients.****Note 15:** The output propagation delay is referenced to the end of the instruction cycle where the output change occurs.**Note 16:** Parameter characterized but not tested.



**Absolute Maximum Ratings** (Note 17)

If Military/Aerospace specified devices are required, please contact the National Semiconductor Sales Office/Distributors for availability and specifications.

Supply Voltage ( $V_{CC}$ ) 7V  
Voltage at Any Pin  $-0.3V$  to  $V_{CC} + 0.3V$

Total Current into  $V_{CC}$  Pin (Source) 100 mA  
Total Current out of GND Pin (Sink) 110 mA  
Storage Temperature Range  $-65^{\circ}C$  to  $+140^{\circ}C$

**Note 17:** Absolute maximum ratings indicate limits beyond which damage to the device may occur. DC and AC electrical specifications are not ensured when operating the device at absolute maximum ratings.

**DC Electrical Characteristics 68xEK:**

$-55^{\circ}C \leq T_A \leq +125^{\circ}C$  unless otherwise specified

Parameter	Conditions	Min	Typ	Max	Units
Operating Voltage		4.5		5.5	V
Power Supply Ripple (Note 19)	Peak-to-Peak			$0.1 V_{CC}$	V
Supply Current (Note 22) CKI = 10 MHz	$V_{CC} = 5.5V$ , $t_c = 1 \mu s$			12.5	mA
HALT Current (Note 21)	$V_{CC} = 5.5V$ , CKI = 0 MHz		<10	30	$\mu A$
IDLE Current (Note 22) CKI = 10 MHz	$V_{CC} = 5.5V$ , $t_c = 1 \mu s$			1.7	mA
Input Levels ( $V_{IH}$ , $V_{IL}$ ) <u>RESET</u> Logic High Logic Low CKI, All Other Inputs Logic High Logic Low		0.8 $V_{CC}$   0.7 $V_{CC}$		0.2 $V_{CC}$   0.2 $V_{CC}$	V V V V
Hi-Z Input Leakage	$V_{CC} = 5.5V$	-5		+5	$\mu A$
Input Pullup Current	$V_{CC} = 5.5V$ , $V_{IN} = 0V$	-35		-400	$\mu A$
G and L Port Input Hysteresis (Note 24)				$0.35 V_{CC}$	V
Output Current Levels D Outputs Source Sink All Others Source (Weak Pull-Up Mode) Source (Push-Pull Mode) Sink (Push-Pull Mode) TRI-STATE Leakage	$V_{CC} = 4.5V$ , $V_{OH} = 3.3V$ $V_{CC} = 4.5V$ , $V_{OL} = 1.0V$  $V_{CC} = 4.5V$ , $V_{OH} = 2.7V$ $V_{CC} = 4.5V$ , $V_{OH} = 3.3V$ $V_{CC} = 4.5V$ , $V_{OL} = 0.4V$ $V_{CC} = 5.5V$	-0.4 9.0  -9.0 -0.4 1.6 -5.0		-110	mA mA $\mu A$ mA mA mA $\mu A$
Allowable Sink/Source Current per Pin D Outputs (Sink) All others				12 2.5	mA mA
Maximum Input Current without Latchup (Note 22)	Room Temp			$\pm 100$	mA
RAM Retention Voltage, $V_r$	500 ns Rise and and Fall Time (min)	2	1.5		V
Input Capacitance				7	pF
Load Capacitance on D2				1000	pF

## AC Electrical Characteristics 68xEK:

$-55^{\circ}\text{C} \leq T_A \leq +125^{\circ}\text{C}$  unless otherwise specified

Parameter	Conditions	Min	Typ	Max	Units
Instruction Cycle Time ( $t_c$ )					
Crystal, Resonator	$4.5\text{V} \leq V_{CC} \leq 5.5\text{V}$	1.0		DC	$\mu\text{s}$
R/C Oscillator	$4.5\text{V} \leq V_{CC} < 5.5\text{V}$	3.0		DC	$\mu\text{s}$
Inputs					
$t_{\text{SETUP}}$	$4.5\text{V} \leq V_{CC} \leq 5.5\text{V}$	200			ns
$t_{\text{HOLD}}$	$4.5\text{V} \leq V_{CC} \leq 5.5\text{V}$	60			ns
Output Propagation Delay (Note 23)	$R_L = 2.2\text{k}, C_L = 100\text{ pF}$				
$t_{\text{PD1}}, t_{\text{PD0}}$					
SO, SK	$4.5\text{V} \leq V_{CC} \leq 5.5\text{V}$			0.7	$\mu\text{s}$
All Others	$4.5\text{V} \leq V_{CC} \leq 5.5\text{V}$			1.0	$\mu\text{s}$
MICROWIRE Setup Time ( $t_{\text{UWS}}$ ) (Note 23)	$V_{CC} \geq 4.5\text{V}$	20			ns
MICROWIRE Hold Time ( $t_{\text{UWH}}$ ) (Note 23)	$V_{CC} \geq 4.5\text{V}$	56			ns
MICROWIRE Output Propagation Delay ( $t_{\text{UPD}}$ )	$V_{CC} \geq 4.5\text{V}$			220	ns
Input Pulse Width (Note 24)					
Interrupt Input High Time		1.0			$t_c$
Interrupt Input Low Time		1.0			$t_c$
Timer 1, 2, 3 Input High Time		1.0			$t_c$
Timer 1, 2, 3 Input Low Time		1.0			$t_c$
Reset Pulse Width		1.0			$\mu\text{s}$

**Note 18:**  $t_c$  = Instruction Cycle Time

**Note 19:** Maximum rate of voltage change must be  $< 0.5\text{ V/ms}$ .

**Note 20:** Supply and IDLE currents are measured with CKI driven with a square wave Oscillator, CKO driven  $180^{\circ}$  out of phase with CKI, inputs connected to  $V_{CC}$  and outputs driven low but not connected to a load.

**Note 21:** The HALT mode will stop CKI from oscillating in the RC and the Crystal configurations. Measurement of  $I_{\text{DD HALT}}$  is done with device neither sourcing nor sinking current; with L, C, G0, and G2–G5 programmed as low outputs and not driving a load; all outputs programmed low and not driving a load; all inputs tied to  $V_{CC}$ ; clock monitor and comparator disabled. Parameter refers to HALT mode entered via setting bit 7 of the G Port data register. Part will pull up CKI during HALT in crystal clock mode.

**Note 22:** Pins G6 and  $\overline{\text{RESET}}$  are designed with a high voltage input network. These pins allow input voltages  $> V_{CC}$  and the pins will have sink current to  $V_{CC}$  when biased at voltages  $> V_{CC}$  (the pins do not have source current when biased at a voltage below  $V_{CC}$ ). The effective resistance to  $V_{CC}$  is  $750\Omega$  (typical). These two pins will not latch up. The voltage at the pins must be limited to  $< 14\text{V}$ . **WARNING: Voltages in excess of 14V will cause damage to the pins. This warning excludes ESD transients.**

**Note 23:** The output propagation delay is referenced to the end of the instruction cycle where the output change occurs.

**Note 24:** Parameter characterized but not tested.

## Analog Function Block AC and DC Characteristics

$V_{CC} = 5.0\text{V}, -40^{\circ}\text{C} \leq T_A \leq +85^{\circ}\text{C}$

Parameter	Conditions	Min	Typ	Max	Units
Input Offset Voltage	$0.4\text{V} < V_{\text{IN}} < V_{CC} - 1.5\text{V}$		$\pm 10$	$\pm 25$	mV
Input Common Mode Voltage Range (Note 26)		0.4		$V_{CC} - 1.5$	V
$V_{CC}/2$ Reference	$4.0\text{V} < V_{CC} < 6.0\text{V}$	$0.5 V_{CC} - 0.04$	$0.5 V_{CC}$	$0.5 V_{CC} + 0.04$	V
DC Supply Current for Comparator (when enabled)	$V_{CC} = 6.0\text{V}$			250	$\mu\text{A}$
DC Supply Current for $V_{CC}/2$ Reference (when enabled)	$V_{CC} = 6.0\text{V}$		50	80	$\mu\text{A}$
DC Supply Current for Constant Current Source (when enabled)	$V_{CC} = 6.0\text{V}$			200	$\mu\text{A}$
Constant Current Source	$4.0\text{V} < V_{CC} < 6.0\text{V}$	10	20	40	$\mu\text{A}$
Current Source Variation over Common Mode Range	$4.0\text{V} < V_{CC} < 6.0\text{V}$ Temp = Constant			$\pm 2$	$\mu\text{A}$
Current Source Enable Time			1.5	2	$\mu\text{s}$

# Analog Function Block AC and DC Characteristics (Continued)

$V_{CC} = 5.0V, -40^{\circ}C \leq T_A \leq +85^{\circ}C$

Parameter	Conditions	Min	Typ	Max	Units
Comparator Response Time	100 mV Overdrive, 100 pF Load			1	$\mu s$

**Note 25:** While performance characteristics are given at  $V_{CC} = 5.0V$ , the analog function block will operate over the entire 2.5V–6.0V  $V_{CC}$  range. Accuracy of the  $V_{CC}/2$  reference and the constant current source is not guaranteed beyond the specified limits.

**Note 26:** The device is capable of operating over a common mode voltage range of 0 to  $V_{CC} - 1.5V$ , however increased offset voltage will be observed between 0V and 0.4V.

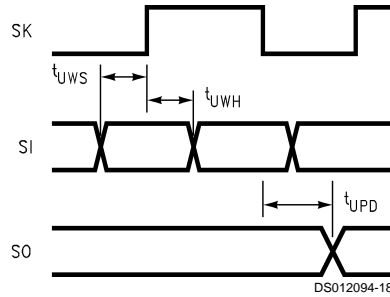
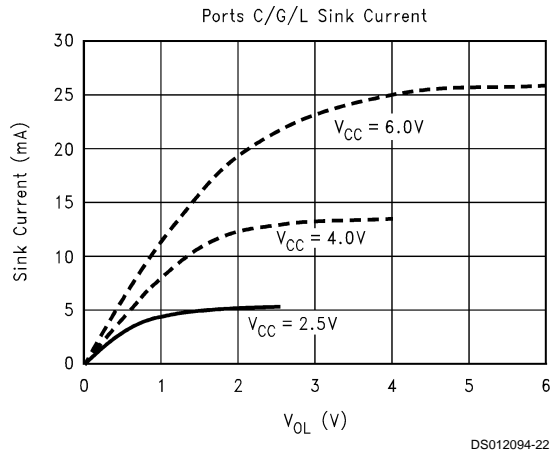
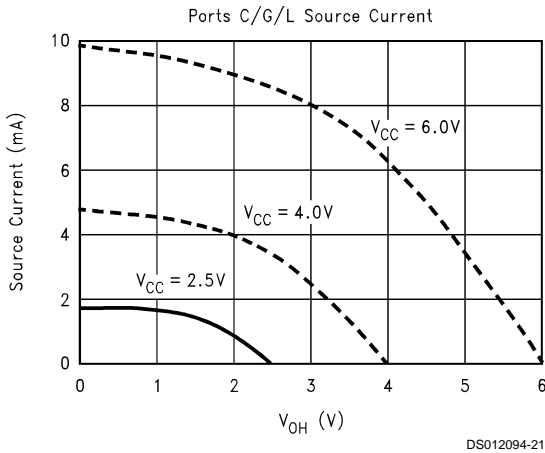
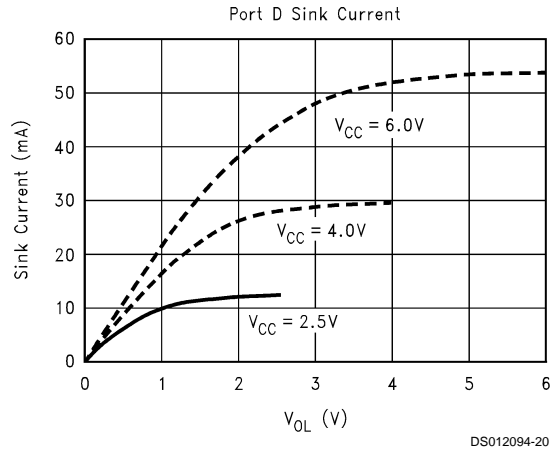
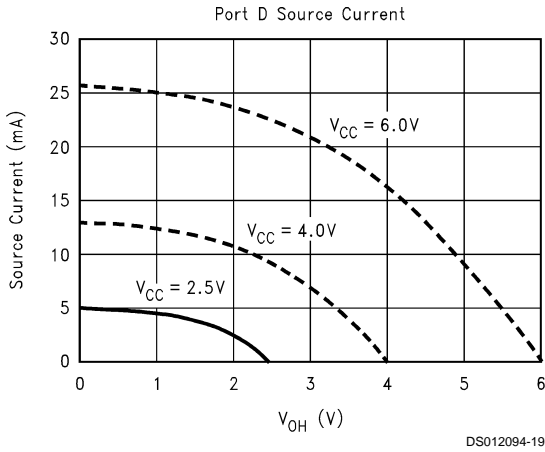
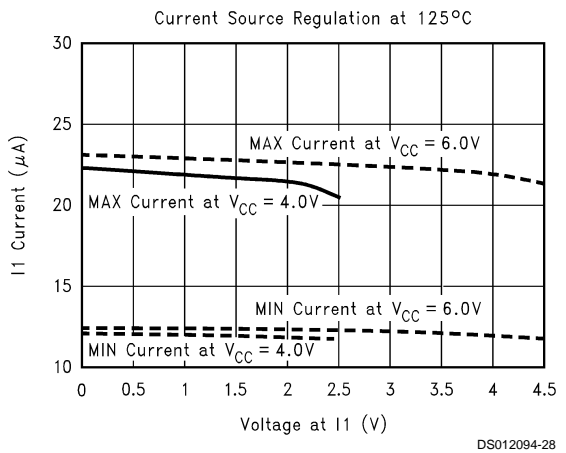
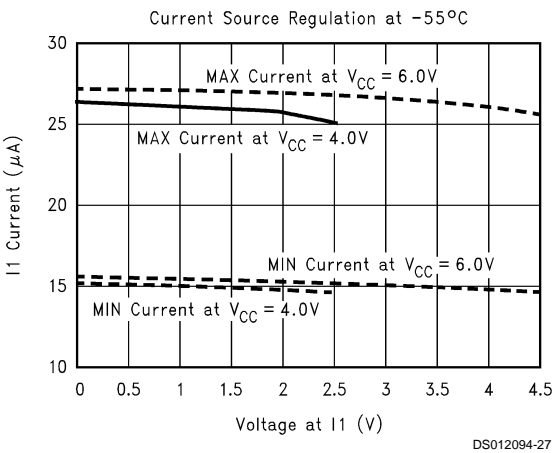
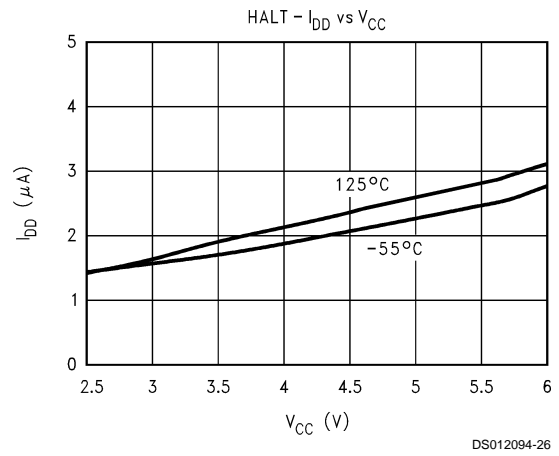
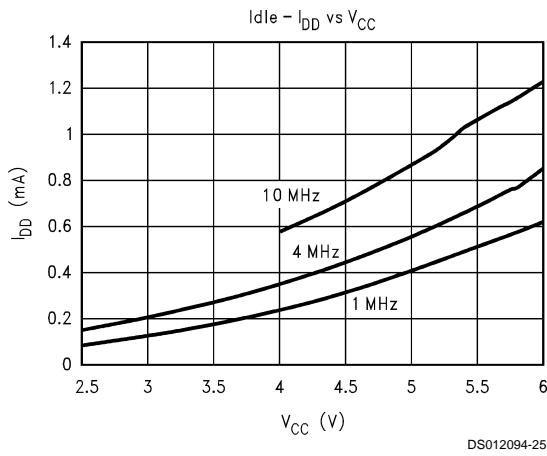
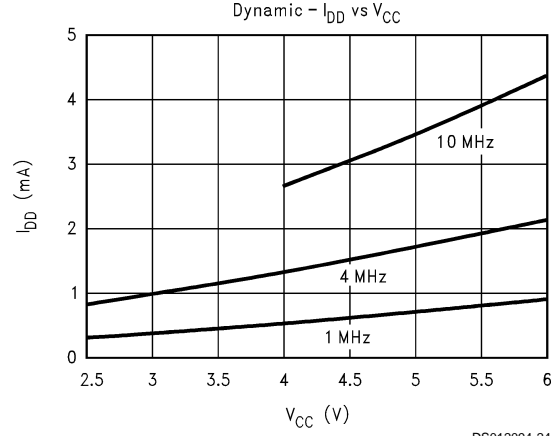
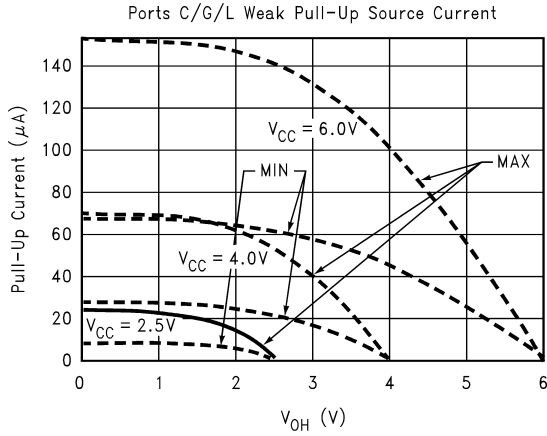

FIGURE 3. MICROWIRE/PLUS Timing

## Typical Performance Characteristics ( $-55^{\circ}C \leq T_A = +125^{\circ}C$ )



Typical Performance Characteristics (-55°C ≤ T<sub>A</sub> = +125°C) (Continued)



## Typical Performance Characteristics ( $-55^{\circ}\text{C} \leq T_A = +125^{\circ}\text{C}$ ) (Continued)

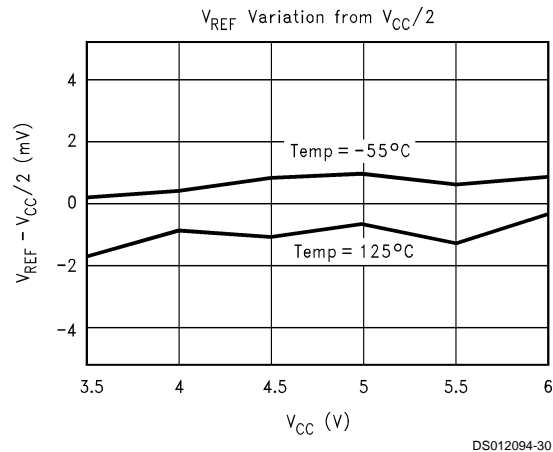
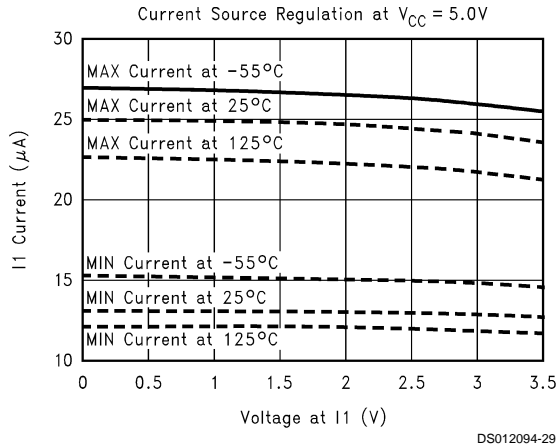

## Pin Descriptions

$V_{CC}$  and GND are the power supply pins. All  $V_{CC}$  and GND pins must be connected.

CKI is the clock input. This can come from an R/C generated oscillator, or a crystal oscillator (in conjunction with CKO). See Oscillator Description section.

$\overline{\text{RESET}}$  is the master reset input. See Reset Description section.

The device contains three bidirectional 8-bit I/O ports (C, G and L), where each individual bit may be independently configured as an input (Schmitt Trigger inputs on ports L and G), output or TRI-STATE under program control. Three data memory address locations are allocated for each of these I/O ports. Each I/O port has two associated 8-bit memory mapped registers, the CONFIGURATION register and the output DATA register. A memory mapped address is also reserved for the input pins of each I/O port. (See the memory map for the various addresses associated with the I/O ports.)

Figure 4 shows the I/O port configurations. The DATA and CONFIGURATION registers allow for each port bit to be individually configured under software control as shown below:

CONFIGURATION Register	DATA Register	Port Set-Up
0	0	Hi-Z Input (TRI-STATE Output)
0	1	Input with Weak Pull-Up
1	0	Push-Pull Zero Output
1	1	Push-Pull One Output

PORT L is an 8-bit I/O port. All L-pins have Schmitt triggers on the inputs.

The Port L supports Multi-Input Wake Up on all eight pins. L4 and L5 are used for the timer input functions T2A and T2B. L6 and L7 are used for the timer input functions T3A and T3B.

The Port L has the following alternate features:

- L7 MIWU or T3B
- L6 MIWU or T3A
- L5 MIWU or T2B
- L4 MIWU or T2A
- L3 MIWU
- L2 MIWU
- L1 MIWU
- L0 MIWU

Port G is an 8-bit port with 5 I/O pins (G0, G2–G5), an input pin (G6), and a dedicated output pin (G7). Pins G0 and G2–G6 all have Schmitt Triggers on their inputs. Pin G1 serves as the dedicated WDOUT WATCHDOG output, while pin G7 is either input or output depending on the oscillator mask option selected. With the crystal oscillator option selected, G7 serves as the dedicated output pin for the CKO clock output. With the single-pin R/C oscillator mask option selected, G7 serves as a general purpose input pin but is also used to bring the device out of HALT mode with a low to high transition on G7. There are two registers associated with the G Port, a data register and a configuration register. Therefore, each of the 5 I/O bits (G0, G2–G5) can be individually configured under software control.

Since G6 is an input only pin and G7 is the dedicated CKO clock output pin (crystal clock option) or general purpose input (R/C clock option), the associated bits in the data and configuration registers for G6 and G7 are used for special purpose functions as outlined on the next page. Reading the G6 and G7 data bits will return zeros.

## Pin Descriptions (Continued)

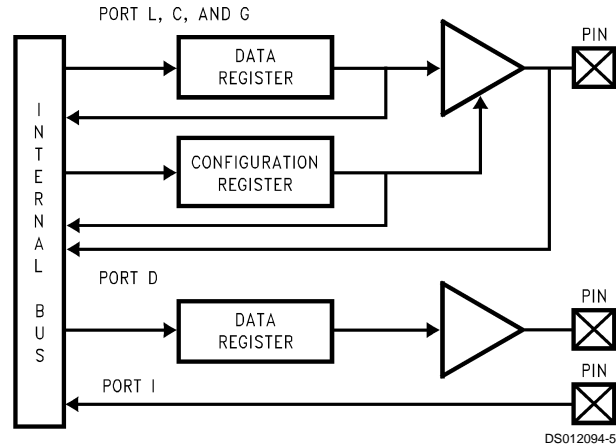

**FIGURE 4. I/O Port Configurations**

Note that the chip will be placed in the HALT mode by writing a “1” to bit 7 of the Port G Data Register. Similarly the chip will be placed in the IDLE mode by writing a “1” to bit 6 of the Port G Data Register.

Writing a “1” to bit 6 of the Port G Configuration Register enables the MICROWIRE/PLUS to operate with the alternate phase of the SK clock. The G7 configuration bit, if set high, enables the clock start up delay after HALT when the R/C clock configuration is used.

	Config Reg.	Data Reg.
G7	CLKDLY	HALT
G6	Alternate SK	IDLE

Port G has the following alternate features:

- G6 SI (MICROWIRE Serial Data Input)
- G5 SK (MICROWIRE Serial Clock)
- G4 SO (MICROWIRE Serial Data Output)
- G3 T1A (Timer T1 I/O)
- G2 T1B (Timer T1 Capture Input)
- G0 INTR (External Interrupt Input)

Port G has the following dedicated functions:

- G7 CKO Oscillator dedicated output or general purpose input
- G1 WDOUT WATCHDOG and/or Clock Monitor dedicated output

Port C is an 8-bit I/O port. The 40-pin device does not have a full complement of Port C pins. The unavailable pins are not terminated. A read operation for these unterminated pins will return unpredictable values.

PORT I is an eight-bit Hi-Z input port. The 28-pin device does not have a full complement of Port I pins. The unavailable pins are not terminated i.e., they are floating. A read operation for these unterminated pins will return unpredictable values. The user must ensure that the software takes this into account by either masking or restricting the accesses to bit operations. The unterminated Port I pins will draw power only when addressed.

Port I is an eight-bit Hi-Z input port.

Port I0–I7 are used for the analog function block.

The Port I has the following alternate features:

- I7 COMPOUT (Comparator Output)
- I6 COMPIN5+ (Comparator Positive Input 5)

- I5 COMPIN4+ (Comparator Positive Input 4)
- I4 COMPIN3+ (Comparator Positive Input 3)
- I3 COMPOUT/COMPIN2+ (Comparator Output/Comparator Positive Input 2))
- I2 COMPIN0+ (Comparator Positive Input 0)
- I1 COMPIN– (Comparator Negative Input/Current Source Out)
- I0 COMPIN1+ (Comparator Positive Input 1)

Port D is an 8-bit output port that is preset high when RESET goes low. The user can tie two or more D port outputs (except D2) together in order to get a higher drive.

**Note:** Care must be exercised with the D2 pin operation. At RESET, the external loads on this pin must ensure that the output voltages stay above  $0.8 V_{CC}$  to prevent the chip from entering special modes. Also keep the external loading on D2 to  $<1000$  pF.

## Functional Description

The architecture of the device is modified Harvard architecture. With the Harvard architecture, the control store program memory (ROM) is separated from the data store memory (RAM). Both ROM and RAM have their own separate addressing space with separate address buses. The architecture, though based on Harvard architecture, permits transfer of data from ROM to RAM.

### CPU REGISTERS

The CPU can do an 8-bit addition, subtraction, logical or shift operation in one instruction ( $t_c$ ) cycle time.

There are six CPU registers:

A is the 8-bit Accumulator Register

PC is the 15-bit Program Counter Register

PU is the upper 7 bits of the program counter (PC)

PL is the lower 8 bits of the program counter (PC)

B is an 8-bit RAM address pointer, which can be optionally post auto incremented or decremented.

X is an 8-bit alternate RAM address pointer, which can be optionally post auto incremented or decremented.

SP is the 8-bit stack pointer, which points to the subroutine/interrupt stack (in RAM). The SP is initialized to RAM address 06F with reset.

## Functional Description (Continued)

S is the 8-bit Data Segment Address Register used to extend the lower half of the address range (00 to 7F) into 256 data segments of 128 bytes each.

All the CPU registers are memory mapped with the exception of the Accumulator (A) and the Program Counter (PC).

### PROGRAM MEMORY

The program memory consists of 8192 bytes of ROM. These bytes may hold program instructions or constant data (data tables for the LAID instruction, jump vectors for the JID instruction, and interrupt vectors for the VIS instruction). The program memory is addressed by the 15-bit program counter (PC). All interrupts in the devices vector to program memory location 0FF Hex.

### DATA MEMORY

The data memory address space includes the on-chip RAM and data registers, the I/O registers (Configuration, Data and Pin), the control registers, the MICROWIRE/PLUS SIO shift register, and the various registers, and counters associated with the timers (with the exception of the IDLE timer). Data memory is addressed directly by the instruction or indirectly by the B, X, SP pointers and S register.

The data memory consists of 256 bytes of RAM. Sixteen bytes of RAM are mapped as "registers" at addresses 0F0 to 0FF Hex. These registers can be loaded immediately, and also decremented and tested with the DRSZ (decrement register and skip if zero) instruction. The memory pointer registers X, SP, B and S are memory mapped into this space at address locations 0FC to 0FF Hex respectively, with the other registers being available for general usage.

The instruction set permits any bit in memory to be set, reset or tested. All I/O and registers (except A and PC) are memory mapped; therefore, I/O bits and register bits can be directly and individually set, reset and tested. The accumulator (A) bits can also be directly and individually tested.

**Note:** RAM contents are undefined upon power-up.

## Data Memory Segment RAM Extension

Data memory address 0FF is used as a memory mapped location for the Data Segment Address Register (S).

The data store memory is either addressed directly by a single byte address within the instruction, or indirectly relative to the reference of the B, X, or SP pointers (each contains a single-byte address). This single-byte address allows an addressing range of 256 locations from 00 to FF hex. The upper bit of this single-byte address divides the data store memory into two separate sections as outlined previously. With the exception of the RAM register memory from address locations 00F0 to 00FF, all RAM memory is memory mapped with the upper bit of the single-byte address being equal to zero. This allows the upper bit of the single-byte address to determine whether or not the base address range (from 0000 to 00FF) is extended. If this upper bit equals one (representing address range 0080 to 00FF), then address extension does not take place. Alternatively, if this upper bit equals zero, then the data segment extension register S is used to extend the base address range (from 0000 to 007F) from XX00 to XX7F, where XX represents the 8 bits from the S register. Thus the 128-byte data segment extensions are located from addresses 0100 to 017F for data segment 1,

0200 to 027F for data segment 2, etc., up to FF00 to FF7F for data segment 255. The base address range from 0000 to 007F represents data segment 0.

Figure 5 illustrates how the S register data memory extension is used in extending the lower half of the base address range (00 to 7F hex) into 256 data segments of 128 bytes each, with a total addressing range of 32 kbytes from XX00 to XX7F. This organization allows a total of 256 data segments of 128 bytes each with an additional upper base segment of 128 bytes. Furthermore, all addressing modes are available for all data segments. The S register must be changed under program control to move from one data segment (128 bytes) to another. However, the upper base segment (containing the 16 memory registers, I/O registers, control registers, etc.) is always available regardless of the contents of the S register, since the upper base segment (address range 0080 to 00FF) is independent of data segment extension.

The instructions that utilize the stack pointer (SP) always reference the stack as part of the base segment (Segment 0), regardless of the contents of the S register. The S register is not changed by these instructions. Consequently, the stack (used with subroutine linkage and interrupts) is always located in the base segment. The stack pointer will be initialized to point at data memory location 006F as a result of reset.

The 128 bytes of RAM contained in the base segment are split between the lower and upper base segments. The first 112 bytes of RAM are resident from address 0000 to 006F in the lower base segment, while the remaining 16 bytes of RAM represent the 16 data memory registers located at addresses 00F0 to 00FF of the upper base segment. No RAM is located at the upper sixteen addresses (0070 to 007F) of the lower base segment.

Additional RAM beyond these initial 128 bytes, however, will always be memory mapped in groups of 128 bytes (or less) at the data segment address extensions (XX00 to XX7F) of the lower base segment. The additional 128 bytes of RAM are memory mapped at address locations 0100 to 017F hex.

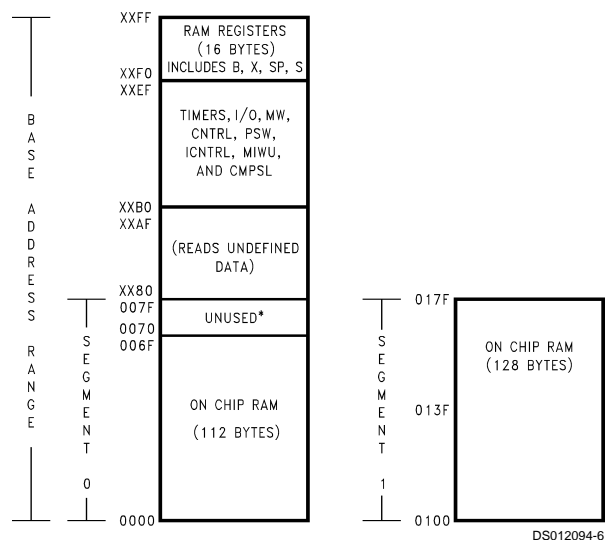

\*Reads as all ones.

FIGURE 5. RAM Organization

## Reset

The  $\overline{\text{RESET}}$  input when pulled low initializes the microcontroller. Initialization will occur whenever the RESET input is pulled low. Upon initialization, the data and configuration registers for ports L, G and C are cleared, resulting in these Ports being initialized to the TRI-STATE mode. Pin G1 of the G Port is an exception (as noted below) since pin G1 is dedicated as the WATCHDOG and/or Clock Monitor error output pin. Port D is set high. The PC, PSW, ICNTRL, CNTRL, T2CNTRL and T3CNTRL control registers are cleared. The Comparator Select Register is cleared. The S register is initialized to zero. The Multi-Input Wakeup registers WKEN and WKEDG are cleared. Wakeup register WKPND is unknown. The stack pointer, SP, is initialized to 6F hex.

The device comes out of reset with both the WATCHDOG logic and the Clock Monitor detector armed, with the WATCHDOG service window bits set and the Clock Monitor bit set. The WATCHDOG and Clock Monitor circuits are inhibited during reset. The WATCHDOG service window bits being initialized high default to the maximum WATCHDOG service window of  $64k t_c$  clock cycles. The Clock Monitor bit being initialized high will cause a Clock Monitor error following reset if the clock has not reached the minimum specified frequency at the termination of reset. A Clock Monitor error will cause an active low error output on pin G1. This error output will continue until  $16 t_c$ – $32 t_c$  clock cycles following the clock frequency reaching the minimum specified value, at which time the G1 output will enter the TRI-STATE mode.

The external RC network shown in *Figure 6* should be used to ensure that the  $\overline{\text{RESET}}$  pin is held low until the power supply to the chip stabilizes.

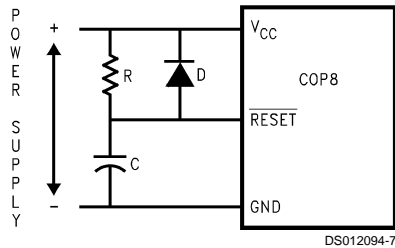

$RC > 5 \times$  Power Supply Rise Time

**FIGURE 6. Recommended Reset Circuit**

## Oscillator Circuits

The chip can be driven by a clock input on the CKI input pin which can be between DC and 10 MHz. The CKO output clock is on pin G7 (crystal configuration). The CKI input frequency is divided down by 10 to produce the instruction cycle clock ( $1/t_c$ ).

**Note:** External clocks with frequencies above about 4 MHz require the user to drive the CKO (G7) pin with a signal 180 degrees out of phase with CKI.

*Figure 7* shows the Crystal and R/C oscillator diagrams.

### CRYSTAL OSCILLATOR

CKI and CKO can be connected to make a closed loop crystal (or resonator) controlled oscillator.

*Table 1* shows the component values required for various standard crystal values.

### R/C OSCILLATOR

By selecting CKI as a single pin oscillator input, a single pin R/C oscillator circuit can be connected to it. CKO is available as a general purpose input, and/or HALT restart input.

**Note:** Use of the R/C oscillator option will result in higher electromagnetic emissions.

*Table 2* shows the variation in the oscillator frequencies as functions of the component (R and C) values.

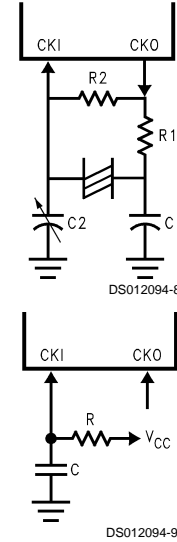

**FIGURE 7. Crystal and R/C Oscillator Diagrams**

**TABLE 1. Crystal Oscillator Configuration,  $T_A = 25^\circ\text{C}$**

R1 (k $\Omega$ )	R2 (M $\Omega$ )	C1 (pF)	C2 (pF)	CKI Freq (MHz)	Conditions
0	1	30	30–36	10	$V_{CC} = 5V$
0	1	30	30–36	4	$V_{CC} = 5V$
0	1	200	100–150	0.455	$V_{CC} = 5V$

**TABLE 2. RC Oscillator Configuration,  $T_A = 25^\circ\text{C}$**

R (k $\Omega$ )	C (pF)	CKI Freq (MHz)	Instr. Cycle ( $\mu\text{s}$ )	Conditions
3.3	82	2.2 to 2.7	3.7 to 4.6	$V_{CC} = 5V$
5.6	100	1.1 to 1.3	7.4 to 9.0	$V_{CC} = 5V$
6.8	100	0.9 to 1.1	8.8 to 10.8	$V_{CC} = 5V$

**Note 27:**  $3k \leq R \leq 200k$

$50 \text{ pF} \leq C \leq 200 \text{ pF}$

## Control Registers

### CNTRL Register (Address X'00EE)

T1C3	T1C2	T1C1	T1C0	MSEL	IEDG	SL1	SL0
Bit 7							Bit 0

The Timer1 (T1) and MICROWIRE/PLUS control register contains the following bits:

T1C3	Timer T1 mode control bit
T1C2	Timer T1 mode control bit
T1C1	Timer T1 mode control bit
T1C0	Timer T1 Start/Stop control in timer modes 1 and 2, T1 Underflow Interrupt Pending Flag in timer mode 3



## Control Registers (Continued)

MSEL	Selects G5 and G4 as MICROWIRE/PLUS signals SK and SO respectively
IEDG	External interrupt edge polarity select (0 = Rising edge, 1 = Falling edge)
SL1 & SL0	Select the MICROWIRE/PLUS clock divide by (00 = 2, 01 = 4, 1x = 8)

### PSW Register (Address X'00EF)

HC	C	T1PND	T1ENA	EXPND	BUSY	EXEN	GIE
Bit 7							Bit 0

The PSW register contains the following select bits:

HC	Half Carry Flag
C	Carry Flag
T1PND	Timer T1 Interrupt Pending Flag (Autoreload RA in mode 1, T1 Underflow in Mode 2, T1A capture edge in mode 3)
T1ENA	Timer T1 Interrupt Enable for Timer Underflow or T1A Input capture edge
EXPND	External interrupt pending
BUSY	MICROWIRE/PLUS busy shifting flag
EXEN	Enable external interrupt
GIE	Global interrupt enable (enables interrupts)

The Half-Carry flag is also affected by all the instructions that affect the Carry flag. The SC (Set Carry) and R/C (Reset Carry) instructions will respectively set or clear both the carry flags. In addition to the SC and R/C instructions, ADC, SUBC, RRC and RLC instructions affect the Carry and Half Carry flags.

### ICNTRL Register (Address X'00E8)

Rsvd	LPEN	T0PND	T0EN	$\mu$ WPND	$\mu$ WEN	T1PNDB	T1ENB
Bit 7							Bit 0

The ICNTRL register contains the following bits:

Rsvd	This bit is reserved and must be zero
LPEN	L Port Interrupt Enable (Multi-Input Wakeup/Interrupt)
T0PND	Timer T0 Interrupt pending
T0EN	Timer T0 Interrupt Enable (Bit 12 toggle)
$\mu$ WPND	MICROWIRE/PLUS interrupt pending
$\mu$ WEN	Enable MICROWIRE/PLUS interrupt
T1PNDB	Timer T1 Interrupt Pending Flag for T1B capture edge
T1ENB	Timer T1 Interrupt Enable for T1B Input capture edge

### T2CNTRL Register (Address X'00C6)

T2C3	T2C2	T2C1	T2C0	T2PND	T2ENA	T2PNDB	T2ENB
Bit 7							Bit 0

The T2CNTRL control register contains the following bits:

T2C3	Timer T2 mode control bit
T2C2	Timer T2 mode control bit
T2C1	Timer T2 mode control bit
T2C0	Timer T2 Start/Stop control in timer modes 1 and 2, T2 Underflow Interrupt Pending Flag in timer mode 3

T2PND	Timer T2 Interrupt Pending Flag (Autoreload RA in mode 1, T2 Underflow in mode 2, T2A capture edge in mode 3)
T2ENA	Timer T2 Interrupt Enable for Timer Underflow or T2A Input capture edge
T2PNDB	Timer T2 Interrupt Pending Flag for T2B capture edge
T2ENB	Timer T2 Interrupt Enable for Timer Underflow or T2B Input capture edge

### T3CNTRL Register (Address X'00B6)

T3C3	T3C2	T3C1	T3C0	T3PND	T3ENA	T3PNDB	T3ENB
Bit 7							Bit 0

The T3CNTRL control register contains the following bits:

T3C3	Timer T3 mode control bit
T3C2	Timer T3 mode control bit
T3C1	Timer T3 mode control bit
T3C0	Timer T3 Start/Stop control in timer modes 1 and 2, T3 Underflow Interrupt Pending Flag in timer mode 3
T3PND	Timer T3 Interrupt Pending Flag (Autoreload RA in mode 1, T3 Underflow in mode 2, T3A capture edge in mode 3)
T3ENA	Timer T3 Interrupt Enable for Timer Underflow or T3A Input capture edge
T3PNDB	Timer T3 Interrupt Pending Flag for T3B capture edge
T3ENB	Timer T3 Interrupt Enable for Timer Underflow or T3B Input capture edge

## Timers

The device contains a very versatile set of timers (T0, T1, T2, T3). All timers and associated autoreload/capture registers power up containing random data.

### TIMER T0 (IDLE TIMER)

The device supports applications that require maintaining real time and low power with the IDLE mode. This IDLE mode support is furnished by the IDLE timer T0, which is a 16-bit timer. The Timer T0 runs continuously at the fixed rate of the instruction cycle clock,  $t_c$ . The user cannot read or write to the IDLE Timer T0, which is a count down timer.

The Timer T0 supports the following functions:

- Exit out of the Idle Mode (See Idle Mode description)
- WATCHDOG logic (See WATCHDOG description)
- Start up delay out of the HALT mode

The IDLE Timer T0 can generate an interrupt when the thirteenth bit toggles. This toggle is latched into the TOPND pending flag, and will occur every 4 ms at the maximum clock frequency ( $t_c = 1 \mu\text{s}$ ). A control flag T0EN allows the interrupt from the thirteenth bit of Timer T0 to be enabled or disabled. Setting T0EN will enable the interrupt, while resetting it will disable the interrupt.

### TIMER T1, TIMER T2 AND TIMER T3

The device has a set of three powerful timer/counter blocks, T1, T2 and T3. The associated features and functioning of a timer block are described by referring to the timer block Tx. Since the three timer blocks, T1, T2 and T3 are identical, all comments are equally applicable to any of the three timer blocks.

## Timers (Continued)

Each timer block consists of a 16-bit timer, Tx, and two supporting 16-bit autoreload/capture registers, RxA and RxB. Each timer block has two pins associated with it, TxA and TxB. The pin TxA supports I/O required by the timer block, while the pin TxB is an input to the timer block. The powerful and flexible timer block allows the device to easily perform all timer functions with minimal software overhead. The timer block has three operating modes: Processor Independent PWM mode, External Event Counter mode, and Input Capture mode.

The control bits TxC3, TxC2, and TxC1 allow selection of the different modes of operation.

### Mode 1. Processor Independent PWM Mode

As the name suggests, this mode allows the device to generate a PWM signal with very minimal user intervention. The user only has to define the parameters of the PWM signal (ON time and OFF time). Once begun, the timer block will continuously generate the PWM signal completely independent of the microcontroller. The user software services the timer block only when the PWM parameters require updating.

In this mode the timer Tx counts down at a fixed rate of  $t_c$ . Upon every underflow the timer is alternately reloaded with the contents of supporting registers, RxA and RxB. The very first underflow of the timer causes the timer to reload from the register RxA. Subsequent underflows cause the timer to be reloaded from the registers alternately beginning with the register RxB.

The Tx Timer control bits, TxC3, TxC2 and TxC1 set up the timer for PWM mode operation.

Figure 8 shows a block diagram of the timer in PWM mode.

The underflows can be programmed to toggle the TxA output pin. The underflows can also be programmed to generate interrupts.

Underflows from the timer are alternately latched into two pending flags, TxPNDA and TxPNDB. The user must reset these pending flags under software control. Two control enable flags, TxENA and TxENB, allow the interrupts from the timer underflow to be enabled or disabled. Setting the timer enable flag TxENA will cause an interrupt when a timer underflow causes the RxA register to be reloaded into the timer. Setting the timer enable flag TxENB will cause an interrupt when a timer underflow causes the RxB register to be reloaded into the timer. Resetting the timer enable flags will disable the associated interrupts.

Either or both of the timer underflow interrupts may be enabled. This gives the user the flexibility of interrupting once per PWM period on either the rising or falling edge of the PWM output. Alternatively, the user may choose to interrupt on both edges of the PWM output.

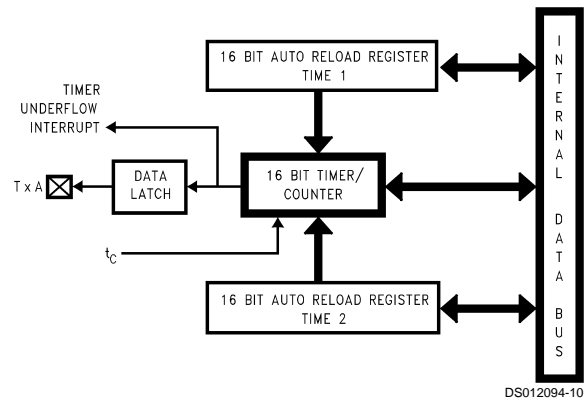

DS012094-10

FIGURE 8. Timer in PWM Mode

### Mode 2. External Event Counter Mode

This mode is quite similar to the processor independent PWM mode described above. The main difference is that the timer, Tx, is clocked by the input signal from the TxA pin. The Tx timer control bits, TxC3, TxC2 and TxC1 allow the timer to be clocked either on a positive or negative edge from the TxA pin. Underflows from the timer are latched into the TxPNDA pending flag. Setting the TxENA control flag will cause an interrupt when the timer underflows.

In this mode the input pin TxB can be used as an independent positive edge sensitive interrupt input if the TxENB control flag is set. The occurrence of a positive edge on the TxB input pin is latched into the TxPNDB flag.

Figure 9 shows a block diagram of the timer in External Event Counter mode.

**Note:** The PWM output is not available in this mode since the TxA pin is being used as the counter input clock.

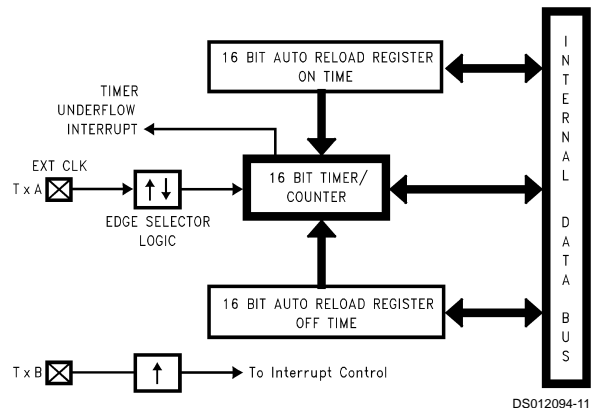

DS012094-11

FIGURE 9. Timer in External Event Counter Mode

## Timers (Continued)

### Mode 3. Input Capture Mode

The device can precisely measure external frequencies or time external events by placing the timer block, Tx, in the input capture mode.

In this mode, the timer Tx is constantly running at the fixed  $t_c$  rate. The two registers, RxA and RxB, act as capture registers. Each register acts in conjunction with a pin. The register RxA acts in conjunction with the TxA pin and the register RxB acts in conjunction with the TxB pin.

The timer value gets copied over into the register when a trigger event occurs on its corresponding pin. Control bits, TxC3, TxC2 and TxC1, allow the trigger events to be specified either as a positive or a negative edge. The trigger condition for each input pin can be specified independently.

The trigger conditions can also be programmed to generate interrupts. The occurrence of the specified trigger condition on the TxA and TxB pins will be respectively latched into the pending flags, TxPNDA and TxPNDB. The control flag TxENA allows the interrupt on TxA to be either enabled or disabled. Setting the TxENA flag enables interrupts to be generated when the selected trigger condition occurs on the TxA pin. Similarly, the flag TxENB controls the interrupts from the TxB pin.

T2 has additional flexibility because T2B can be internally connected to the comparator output of the Analog Function Block. This allows the user to capture the time of a comparator event without using external pins.

Underflows from the timer can also be programmed to generate interrupts. Underflows are latched into the timer TxC0 pending flag (the TxC0 control bit serves as the timer underflow interrupt pending flag in the Input Capture mode). Consequently, the TxC0 control bit should be reset when entering the Input Capture mode. The timer underflow interrupt is enabled with the TxENA control flag. When a TxA interrupt occurs in the Input Capture mode, the user must check both the TxPNDA and TxC0 pending flags in order to determine whether a TxA input capture or a timer underflow (or both) caused the interrupt.

Figure 10 shows a block diagram of the timer in Input Capture mode.

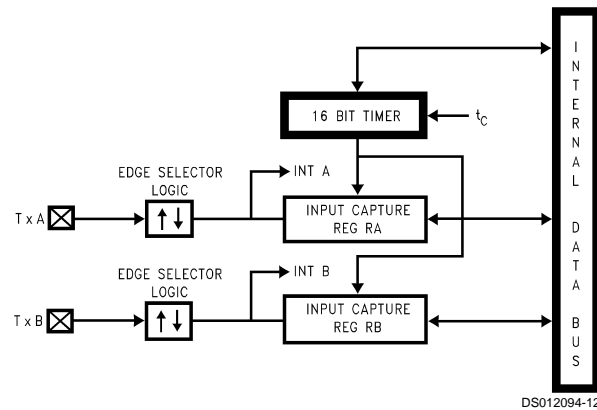

FIGURE 10. Timer in Input Capture Mode

### TIMER CONTROL FLAGS

The control bits and their functions are summarized below.

TxC3	Timer mode control
TxC2	Timer mode control
TxC1	Timer mode control
TxC0	Timer Start/Stop control in Modes 1 and 2 (Processor Independent PWM and External Event Counter), where 1 = Start, 0 = Stop Timer Underflow Interrupt Pending Flag in Mode 3 (Input Capture)
TxPNDA	Timer Interrupt Pending Flag
TxENA	Timer Interrupt Enable Flag 1 = Timer Interrupt Enabled 0 = Timer Interrupt Disabled
TxPNDB	Timer Interrupt Pending Flag
TxENB	Timer Interrupt Enable Flag 1 = Timer Interrupt Enabled 0 = Timer Interrupt Disabled

## Timers (Continued)

The timer mode control bits (TxC3, TxC2 and TxC1) are detailed below:

Mode	TxC3	TxC2	TxC1	Description	Interrupt A Source	Interrupt B Source	Timer Counts On
1	1	0	1	PWM: TxA Toggle	Autoreload RA	Autoreload RB	$t_c$
	1	0	0	PWM: No TxA Toggle	Autoreload RA	Autoreload RB	$t_c$
2	0	0	0	External Event Counter	Timer Underflow	Pos. TxB Edge	Pos. TxA Edge
	0	0	1	External Event Counter	Timer Underflow	Pos. TxB Edge	Pos. TxA Edge
3	0	1	0	Captures: TxA Pos. Edge TxB Pos. Edge	Pos. TxA Edge or Timer Underflow	Pos. TxB Edge	$t_c$
	1	1	0	Captures: TxA Pos. Edge TxB Neg. Edge	Pos. TxA Edge or Timer Underflow	Neg. TxB Edge	$t_c$
	0	1	1	Captures: TxA Neg. Edge TxB Neg. Edge	Neg. TxA Edge or Timer Underflow	Neg. TxB Edge	$t_c$
	1	1	1	Captures: TxA Neg. Edge TxB Neg. Edge	Neg. TxA Edge or Timer Underflow	Neg. TxB Edge	$t_c$

## Power Save Modes

The device offers the user two power save modes of operation: HALT and IDLE. In the HALT mode, all microcontroller activities are stopped. In the IDLE mode, the on-board oscillator circuitry the WATCHDOG logic, the Clock Monitor and timer T0 are active but all other microcontroller activities are stopped. In either mode, all on-board RAM, registers, I/O states, and timers (with the exception of T0) are unaltered.

### HALT MODE

The device can be placed in the HALT mode by writing a "1" to the HALT flag (G7 data bit). All microcontroller activities, including the clock and timers, are stopped. The WATCHDOG logic is disabled during the HALT mode. However, the clock monitor circuitry if enabled remains active and will cause the WATCHDOG output pin (WDOUT) to go low. If the HALT mode is used and the user does not want to activate the WDOUT pin, the Clock Monitor should be disabled after the device comes out of reset (resetting the Clock Monitor control bit with the first write to the WDSVR register). In the HALT mode, the power requirements of the device are minimal and the applied voltage ( $V_{CC}$ ) may be decreased to  $V_r$  ( $V_r = 2.0V$ ) without altering the state of the machine.

The device supports three different ways of exiting the HALT mode. The first method of exiting the HALT mode is with the Multi-Input Wakeup feature on the L port. The second method is with a low to high transition on the CKO (G7) pin. This method precludes the use of the crystal clock configuration (since CKO becomes a dedicated output), and so may be used with an RC clock configuration. The third method of exiting the HALT mode is by pulling the  $\overline{RESET}$  pin low.

Since a crystal or ceramic resonator may be selected as the oscillator, the Wakeup signal is not allowed to start the chip running immediately since crystal oscillators and ceramic

resonators have a delayed start up time to reach full amplitude and frequency stability. The IDLE timer is used to generate a fixed delay to ensure that the oscillator has indeed stabilized before allowing instruction execution. In this case, upon detecting a valid Wakeup signal, only the oscillator circuitry is enabled. The IDLE timer is loaded with a value of 256 and is clocked with the  $t_c$  instruction cycle clock. The  $t_c$  clock is derived by dividing the oscillator clock down by a factor of 10. The Schmitt trigger following the CKI inverter on the chip ensures that the IDLE timer is clocked only when the oscillator has a sufficiently large amplitude to meet the Schmitt trigger specifications. This Schmitt trigger is not part of the oscillator closed loop. The startup timeout from the IDLE timer enables the clock signals to be routed to the rest of the chip.

If an RC clock option is being used, the fixed delay is introduced optionally. A control bit, CLKDLY, mapped as configuration bit G7, controls whether the delay is to be introduced or not. The delay is included if CLKDLY is set, and excluded if CLKDLY is reset. The CLKDLY bit is cleared on reset.

The device has two mask options associated with the HALT mode. The first mask option enables the HALT mode feature, while the second mask option disables the HALT mode. With the HALT mode enable mask option, the device will enter and exit the HALT mode as described above. With the HALT disable mask option, the device cannot be placed in the HALT mode (writing a "1" to the HALT flag will have no effect, the HALT flag will remain "0").

The WATCHDOG detector circuit is inhibited during the HALT mode. However, the clock monitor circuit if enabled remains active during HALT mode in order to ensure a clock monitor error if the device inadvertently enters the HALT mode as a result of a runaway program or power glitch.



## Multi-Input Wakeup (Continued)

If the L port bits have been used as outputs and then changed to inputs with Multi-Input Wakeup/Interrupt, a safety procedure should also be followed to avoid inherited pseudo wakeup conditions. After the selected L port bits have been changed from output to input but before the associated WKEN bits are enabled, the associated edge select bits in WKEDG should be set or reset for the desired edge selects, followed by the associated WKPND bits being cleared.

This same procedure should be used following reset, since the L port inputs are left floating as a result of reset.

The occurrence of the selected trigger condition for Multi-Input Wakeup is latched into a pending register called WKPND. The respective bits of the WKPND register will be set on the occurrence of the selected trigger edge on the corresponding Port L pin. The user has the responsibility of clearing these pending flags. Since WKPND is a pending register for the occurrence of selected wakeup conditions, the device will not enter the HALT mode if any Wakeup bit is both enabled and pending. Consequently, the user has the responsibility of clearing the pending flags before attempting to enter the HALT mode.

WKEN, WKPND and WKEDG are all read/write registers, and are cleared at reset.

## Analog Function Block

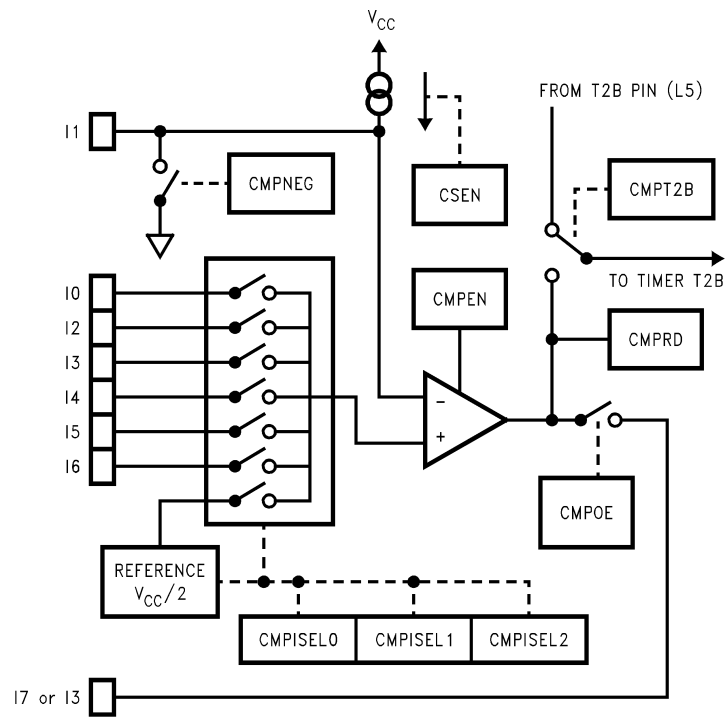

FIGURE 12. COP888EK Analog Function Block

## PORT L INTERRUPTS

Port L provides the user with an additional eight fully selectable, edge sensitive interrupts which are all vectored into the same service subroutine.

The interrupt from Port L shares logic with the wake up circuitry. The register WKEN allows interrupts from Port L to be individually enabled or disabled. The register WKEDG specifies the trigger condition to be either a positive or a negative edge. Finally, the register WKPND latches in the pending trigger conditions.

The GIE (Global Interrupt Enable) bit enables the interrupt function.

A control flag, LPEN, functions as a global interrupt enable for Port L interrupts. Setting the LPEN flag will enable interrupts and vice versa. A separate global pending flag is not needed since the register WKPND is adequate.

Since Port L is also used for waking the device out of the HALT or IDLE modes, the user can elect to exit the HALT or IDLE modes either with or without the interrupt enabled. If he elects to disable the interrupt, then the device will restart execution from the instruction immediately following the instruction that placed the microcontroller in the HALT or IDLE modes. In the other case, the device will first execute the interrupt service routine and then revert to normal operation. (See HALT MODE for clock option wakeup information.)

## Analog Function Block (Continued)

This device contains an analog function block with the intent to provide a function which allows for single slope, low cost, A/D conversion of up to 6 channels. See Application Note 983, Simple, Cost Effective A/D Conversion using COP888EK, for further information on this application.

### CMPSL REGISTER (ADDRESS X'00B7)

CMPT2B	CMPISEL2	CMPISEL1	CMPISEL0	CMPOE	CSEN	COMPEN	COMPNEG
Bit 7						Bit 0	

The CMPSL register contains the following bits:

CMPT2B	Selects the timer T2B input to be driven directly by the comparator output. If the comparator is disabled (COMPEN = 0), this function is disabled, i.e., the T2B input is connected to Port L5.
CMPISEL0/1/2	Will select one of seven possible sources (I0/I2/I3/I4/I5/I6/internal reference) as a positive input to the comparator (see Table 3 for more information.) Power savings can be realized by deselecting the internal reference when it is not in actual use.
CMPOE	Enables the comparator output to either pin I3 or pin I7 ("1" = enable) depending on the value of CMPISEL0/1/2.
CSEN	Enables the internal constant current

source. This current source provides a nominal 20  $\mu$ A constant current at the I1 pin. This current can be used to ensure a linear charging rate on an external capacitor. This bit has no affect and the current source is disabled if the comparator is not enabled (COMPEN = 0).

COMPEN

Enable the comparator ("1" = enable).

COMPNEG

Will drive I1 to a low level. This bit can be used to discharge an external capacitor. This bit is disabled if the comparator is not enabled (COMPEN = 0).

The Comparator Select Register is cleared on RESET (the comparator is disabled). To save power the program should also disable the comparator before the  $\mu$ C enters the HALT/IDLE modes. Disabling the comparator will turn off the constant current source and the  $V_{CC}/2$  reference, disconnect the comparator output from the T2B input and pin I3 or I7 and remove the low on I1 caused by COMPNEG.

It is often useful for the user's program to read the result of a comparator operation. Since I1 is always selected to be COMPIN- when the comparator is enabled (COMPEN = 1), the comparator output can be read internally by reading bit 1 (CMPRD) of register PORTI (RAM address 0 x D7).

The following table lists the comparator inputs and outputs vs. the value of the CMPISEL0/1/2 bits. The output will only be driven if the CMPOE bit is set to 1.

TABLE 3. Comparator Input Selection

Control Bit			Comparator Input Source		Comparator Output
CMPISEL2	CMPISEL1	CMPISEL0	Neg. Input	Pos. Input	
0	0	0	I1	I2	I3
0	0	1	I1	I2	I7
0	1	0	I1	I3	I7
0	1	1	I1	I0	I7
1	0	0	I1	I4	I7
1	0	1	I1	I5	I7
1	1	0	I1	I6	I7
1	1	1	I1	$V_{CC}/2$ Ref.	I7

### RESET

The state of the Comparator Block immediately after RESET is as follows:

1. The CMPSL Register is set to all zeros
2. The Comparator is disabled
3. The Constant Current Source is disabled
4. COMPNEG is turned off
5. The Port I inputs are electrically isolated from the comparator
6. The T2B input is as normally selected by the T2CNTRL Register
7. CMPISEL0-CMPISEL2 are set to zero
8. All Port I inputs are selected to the default digital input mode

The comparator outputs have the same specification as Ports L and G except that the rise and fall times are symmetrical.

### Interrupts

Each device supports eleven vectored interrupts. Interrupt sources include Timer 0, Timer 1, Timer 2, Timer 3, Port L Wakeup, Software Trap, MICROWIRE/PLUS, and External Input.

All interrupts force a branch to location 00FF Hex in program memory. The VIS instruction may be used to vector to the appropriate service routine from location 00FF Hex.

The Software trap has the highest priority while the default VIS has the lowest priority.

Each of the 11 maskable inputs has a fixed arbitration ranking and vector.

Figure 13 shows the Interrupt Block Diagram.

## Interrupts (Continued)

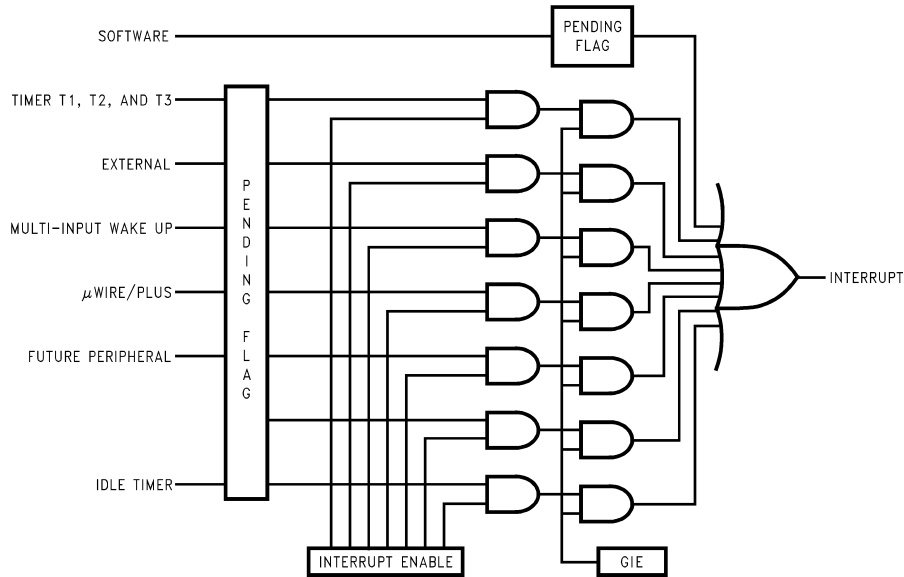

DS012094-15

**FIGURE 13. Interrupt Block Diagram**

### MASKABLE INTERRUPTS

All interrupts other than the Software Trap are maskable. Each maskable interrupt has an associated enable bit and pending flag bit. The pending bit is set to 1 when the interrupt condition occurs. The state of the interrupt enable bit, combined with the GIE bit determines whether an active pending flag actually triggers an interrupt. All of the maskable interrupt pending and enable bits are contained in mapped control registers, and thus can be controlled by the software.

A maskable interrupt condition triggers an interrupt under the following conditions:

1. The enable bit associated with that interrupt is set.
2. The GIE bit is set.
3. The device is not processing a non-maskable interrupt. (If a non-maskable interrupt is being serviced, a maskable interrupt must wait until that service routine is completed.)

An interrupt is triggered only when all of these conditions are met at the beginning of an instruction. If different maskable interrupts meet these conditions simultaneously, the highest priority interrupt will be serviced first, and the other pending interrupts must wait.

Upon Reset, all pending bits, individual enable bits, and the GIE bit are reset to zero. Thus, a maskable interrupt condition cannot trigger an interrupt until the program enables it by setting both the GIE bit and the individual enable bit. When enabling an interrupt, the user should consider whether or not a previously activated (set) pending bit should be acknowledged. If, at the time an interrupt is enabled, any previous occurrences of the interrupt should be ignored, the associated pending bit must be reset to zero prior to enabling the interrupt. Otherwise, the interrupt may be simply enabled; if the pending bit is already set, it will immediately trigger an interrupt. A maskable interrupt is active if its associated enable and pending bits are set.

An interrupt is an asynchronous event which may occur before, during, or after an instruction cycle. Any interrupt which occurs during the execution of an instruction is not acknowl-

edged until the start of the next normally executed instruction is to be skipped, the skip is performed before the pending interrupt is acknowledged.

At the start of interrupt acknowledgment, the following actions occur:

1. The GIE bit is automatically reset to zero, preventing any subsequent maskable interrupt from interrupting the current service routine. This feature prevents one maskable interrupt from interrupting another one being serviced.
2. The address of the instruction about to be executed is pushed onto the stack.
3. The program counter (PC) is loaded with 00FF Hex, causing a jump to that program memory location.

The device requires seven instruction cycles to perform the actions listed above.

If the user wishes to allow nested interrupts, the interrupts service routine may set the GIE bit to 1 by writing to the PSW register, and thus allow other maskable interrupts to interrupt the current service routine. If nested interrupts are allowed, caution must be exercised. The user must write the program in such a way as to prevent stack overflow, loss of saved context information, and other unwanted conditions.

The interrupt service routine stored at location 00FF Hex should use the VIS instruction to determine the cause of the interrupt, and jump to the interrupt handling routine corresponding to the highest priority enabled and active interrupt. Alternately, the user may choose to poll all interrupt pending and enable bits to determine the source(s) of the interrupt. If more than one interrupt is active, the user's program must decide which interrupt to service.

Within a specific interrupt service routine, the associated pending bit should be cleared. This is typically done as early as possible in the service routine in order to avoid missing the next occurrence of the same type of interrupt event. Thus, if the same event occurs a second time, even while the first occurrence is still being serviced, the second occurrence will be serviced immediately upon return from the current interrupt routine.



## Interrupts (Continued)

An interrupt service routine typically ends with an RETI instruction. This instruction sets the GIE bit back to 1, pops the address stored on the stack, and restores that address to the program counter. Program execution then proceeds with the next instruction that would have been executed had there been no interrupt. If there are any valid interrupts pending, the highest-priority interrupt is serviced immediately upon return from the previous interrupt.

### VIS INSTRUCTION

The general interrupt service routine, which starts at address 00FF Hex, must be capable of handling all types of interrupts. The VIS instruction, together with an interrupt vector table, directs the device to the specific interrupt handling routine based on the cause of the interrupt.

VIS is a single-byte instruction, typically used at the very beginning of the general interrupt service routine at address 00FF Hex, or shortly after that point, just after the code used for context switching. The VIS instruction determines which enabled and pending interrupt has the highest priority, and causes an indirect jump to the address corresponding to that interrupt source. The jump addresses (vectors) for all possible interrupts sources are stored in a vector table.

The vector table may be as long as 32 bytes (maximum of 16 vectors) and resides at the top of the 256-byte block containing the VIS instruction. However, if the VIS instruction is at the very top of a 256-byte block (such as at 00FF Hex), the vector table resides at the top of the next 256-byte block. Thus, if the VIS instruction is located somewhere between 00FF and 01DF Hex (the usual case), the vector table is located between addresses 01E0 and 01FF Hex. If the VIS instruction is located between 01FF and 02DF Hex, then the vector table is located between addresses 02E0 and 02FF Hex, and so on.

Each vector is 15 bits long and points to the beginning of a specific interrupt service routine somewhere in the 32 kbyte memory space. Each vector occupies two bytes of the vector table, with the higher-order byte at the lower address. The vectors are arranged in order of interrupt priority. The vector of the maskable interrupt with the lowest rank is located at 0yE0 (higher-order byte) and 0yE1 (lower-order byte). The next priority interrupt is located at 0yE2 and 0yE3, and so forth in increasing rank. The Software Trap has the highest rank and its vector is always located at 0yFE and 0yFF. The number of interrupts which can become active defines the size of the table.

*Table 4* shows the types of interrupts, the interrupt arbitration ranking, and the locations of the corresponding vectors in the vector table.

The vector table should be filled by the user with the memory locations of the specific interrupt service routines. For example, if the Software Trap routine is located at 0310 Hex, then the vector location 0yFE and -0yFF should contain the data 03 and 10 Hex, respectively. When a Software Trap interrupt occurs and the VIS instruction is executed, the program jumps to the address specified in the vector table.

The interrupt sources in the vector table are listed in order of rank, from highest to lowest priority. If two or more enabled and pending interrupts are detected at the same time, the one with the highest priority is serviced first. Upon return from the interrupt service routine, the next highest-level pending interrupt is serviced.

If the VIS instruction is executed, but no interrupts are enabled and pending, the lowest-priority interrupt vector is used, and a jump is made to the corresponding address in the vector table. This is an unusual occurrence, and may be the result of an error. It can legitimately result from a change in the enable bits or pending flags prior to the execution of the VIS instruction, such as executing a single cycle instruction which clears an enable flag at the same time that the pending flag is set. It can also result, however, from inadvertent execution of the VIS command outside of the context of an interrupt.

The default VIS interrupt vector can be useful for applications in which time critical interrupts can occur during the servicing of another interrupt. Rather than restoring the program context (A, B, X, etc.) and executing the RETI instruction, an interrupt service routine can be terminated by returning to the VIS instruction. In this case, interrupts will be serviced in turn until no further interrupts are pending and the default VIS routine is started. After testing the GIE bit to ensure that execution is not erroneous, the routine should restore the program context and execute the RETI to return to the interrupted program.

This technique can save up to fifty instruction cycles ( $t_c$ ), or more, (50 $\mu$ s at 10 MHz oscillator) of latency for pending interrupts with a penalty of fewer than ten instruction cycles if no further interrupts are pending.

To ensure reliable operation, the user should always use the VIS instruction to determine the source of an interrupt. Although it is possible to poll the pending bits to detect the source of an interrupt, this practice is not recommended. The use of polling allows the standard arbitration ranking to be altered, but the reliability of the interrupt system is compromised. The polling routine must individually test the enable and pending bits of each maskable interrupt. If a Software Trap interrupt should occur, it will be serviced last, even though it should have the highest priority. Under certain conditions, a Software Trap could be triggered but not serviced, resulting in an inadvertent "locking out" of all maskable interrupts by the Software Trap pending flag. Problems such as this can be avoided by using VIS instruction.

## Interrupts (Continued)

TABLE 4. Interrupt Vector Table

Arbitration Ranking	Source	Description	Vector (Note 28) Address Hi-Low Byte
(1) Highest	Software	INTR Instruction	0yFE–0yFF
	Reserved		0yFC–0yFD
(2)	External	G0	0yFA–0yFB
(3)	Timer T0	Underflow	0yF8–0yF9
(4)	Timer T1	T1A/Underflow	0yF6–0yF7
(5)	Timer T1	T1B	0yF4–0yF5
(6)	MICROWIRE/PLUS	BUSY Low	0yF2–0yF3
	Reserved		0yF0–0yF1
(7)	Reserved		0yEE–0yEF
(8)	Reserved		0yEC–0yED
(9)	Timer T2	T2A/Underflow	0yEA–0yEB
(10)	Timer T2	T2B	0yE8–0yE9
(11)	Timer T3	T3A/Underflow	0yE6–0yE7
(12)	Timer T3	T3B	0yE4–0yE5
(13)	Port L/Wakeup	Port L Edge	0yE2–0yE3
(14) Lowest	Default	VIS Instr. Execution without Any Interrupts	0yE0–0yE1

**Note 28:** y is a variable which represents the VIS block. VIS and the vector table must be located in the same 256-byte block except if VIS is located at the last address of a block. In this case, the table must be in the next block.

### VIS Execution

When the VIS instruction is executed it activates the arbitration logic. The arbitration logic generates an even number between E0 and FE (E0, E2, E4, E6 etc...) depending on which active interrupt has the highest arbitration ranking at the time of the 1st cycle of VIS is executed. For example, if the software trap interrupt is active, FE is generated. If the external interrupt is active and the software trap interrupt is not, then FA is generated and so forth. If the only active interrupt is software trap, then E0 is generated. This number replaces the lower byte of the PC. The upper byte of the PC remains unchanged. The new PC is therefore pointing to the

vector of the active interrupt with the highest arbitration ranking. This vector is read from program memory and placed into the PC which is now pointed to the 1st instruction of the service routine of the active interrupt with the highest arbitration ranking.

*Figure 14* illustrates the different steps performed by the VIS instruction. *Figure 15* shows a flowchart for the VIS instruction.

The non-maskable interrupt pending flag is cleared by the RPND (Reset Non-Maskable Pending Bit) instruction (under certain conditions) and upon RESET.

Interrupts (Continued)

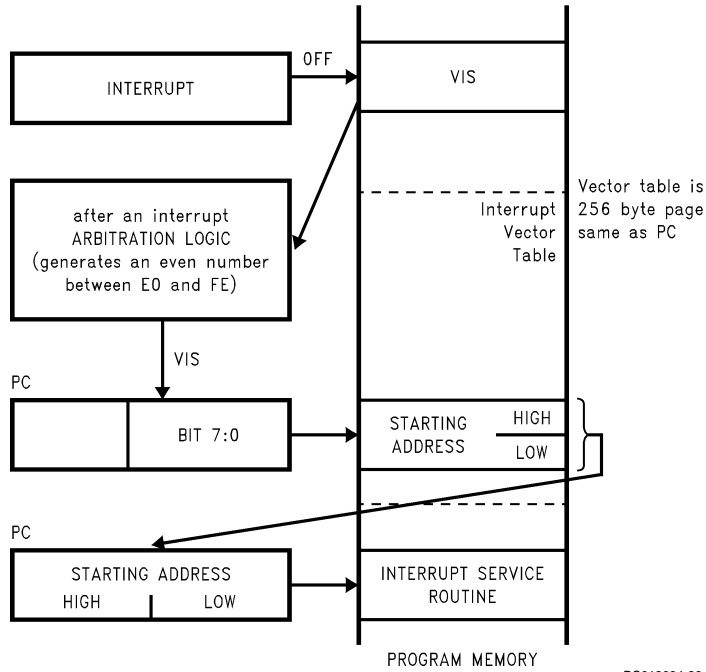

FIGURE 14. VIS Operation

DS012094-29

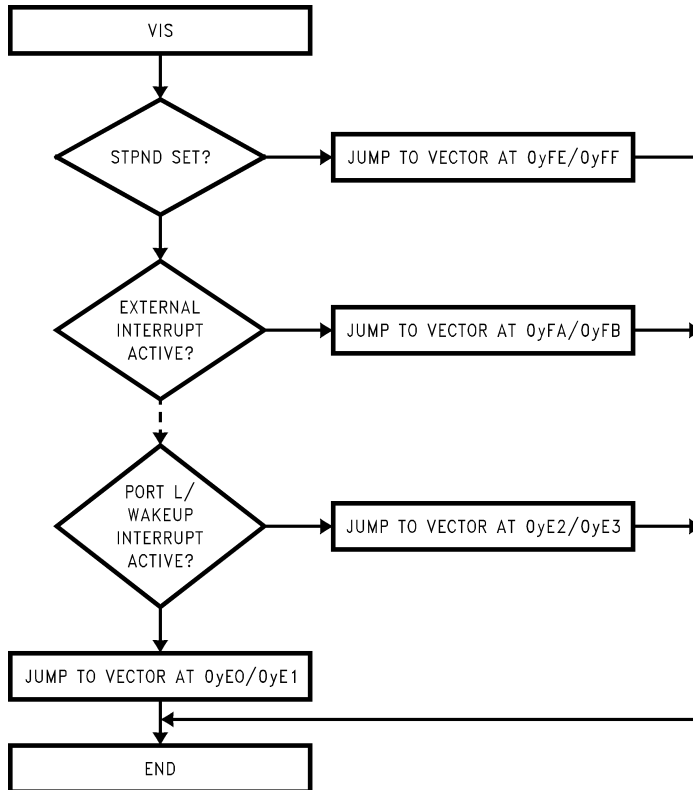

FIGURE 15. VIS Flowchart

DS012094-30

## Interrupts (Continued)

### Programming Example: External Interrupt

```

        PSW          =00EF
        CNTRL        =00EE
        RBIT         0,PORTGC
        RBIT         0,PORTGD      ; G0 pin configured Hi-Z
        SBIT         IEDG, CNTRL   ; Ext interrupt polarity; falling edge
        SBIT         EXEN, PSW     ; Enable the external interrupt
        SBIT         GIE, PSW     ; Set the GIE bit
WAIT:   JP          WAIT          ; Wait for external interrupt
        .
        .
        .
        .=0FF                ; The interrupt causes a
        VIS              ; branch to address 0FF
                          ; The VIS causes a branch to
                          ; interrupt vector table
        .
        .
        .
        .=01FA                ; Vector table (within 256 byte
        .ADDRW SERVICE      ; of VIS inst.) containing the ext
                          ; interrupt service routine
        .
        .
INT_EXIT: RETI
        .
        .
SERVICE: RBIT      EXPND, PSW    ; Interrupt Service Routine
                          ; Reset ext interrupt pend. bit
        .
        .
        .
        JP      INT_EXIT        ; Return, set the GIE bit

```

## Interrupts (Continued)

### NON-MASKABLE INTERRUPT

#### Pending Flag

There is a pending flag bit associated with the non-maskable interrupt, called STPND. This pending flag is not memory-mapped and cannot be accessed directly by the software.

The pending flag is reset to zero when a device Reset occurs. When the non-maskable interrupt occurs, the associated pending bit is set to 1. The interrupt service routine should contain an RPND instruction to reset the pending flag to zero. The RPND instruction always resets the STPND flag.

#### Software Trap

The Software Trap is a special kind of non-maskable interrupt which occurs when the INTR instruction (used to acknowledge interrupts) is fetched from program memory and placed in the instruction register. This can happen in a variety of ways, usually because of an error condition. Some examples of causes are listed below.

If the program counter incorrectly points to a memory location beyond the available program memory space, the non-existent or unused memory location returns zeroes which is interpreted as the INTR instruction.

If the stack is popped beyond the allowed limit (address 06F Hex), a 7FFF will be loaded into the PC, if this last location in program memory is unprogrammed or unavailable, a Software Trap will be triggered.

A Software Trap can be triggered by a temporary hardware condition such as a brownout or power supply glitch.

The Software Trap has the highest priority of all interrupts. When a Software Trap occurs, the STPND bit is set. The GIE bit is not affected and the pending bit (not accessible by the user) is used to inhibit other interrupts and to direct the program to the ST service routine with the VIS instruction. Nothing can interrupt a Software Trap service routine except for another Software Trap. The STPND can be reset only by the RPND instruction or a chip Reset.

The Software Trap indicates an unusual or unknown error condition. Generally, returning to normal execution at the point where the Software Trap occurred cannot be done reliably. Therefore, the Software Trap service routine should reinitialize the stack pointer and perform a recovery procedure that restarts the software at some known point, similar to a device Reset, but not necessarily performing all the same functions as a device Reset. The routine must also execute the RPND instruction to reset the STPND flag. Otherwise, all other interrupts will be locked out. To the extent possible, the interrupt routine should record or indicate the context of the device so that the cause of the Software Trap can be determined.

If the user wishes to return to normal execution from the point at which the Software Trap was triggered, the user must first execute RPND, followed by RETSK rather than RETI or RET. This is because the return address stored on the stack is the address of the INTR instruction that triggered the interrupt. The program must skip that instruction in order to proceed with the next one. Otherwise, an infinite loop of Software Traps and returns will occur.

Programming a return to normal execution requires careful consideration. If the Software Trap routine is interrupted by another Software Trap, the RPND instruction in the service routine for the second Software Trap will reset the STPND

flag; upon return to the first Software Trap routine, the STPND flag will have the wrong state. This will allow maskable interrupts to be acknowledged during the servicing of the first Software Trap. To avoid problems such as this, the user program should contain the Software Trap routine to perform a recovery procedure rather than a return to normal execution.

Under normal conditions, the STPND flag is reset by a RPND instruction in the Software Trap service routine. If a programming error or hardware condition (brownout, power supply glitch, etc.) sets the STPND flag without providing a way for it to be cleared, all other interrupts will be locked out. To alleviate this condition, the user can use extra RPND instructions in the main program and in the WATCHDOG service routine (if present). There is no harm in executing extra RPND instructions in these parts of the program.

### PORT L INTERRUPTS

Port L provides the user with an additional eight fully selectable, edge sensitive interrupts which are all vectored into the same service subroutine.

The interrupt from Port L shares logic with the wake up circuitry. The register WKEN allows interrupts from Port L to be individually enabled or disabled. The register WKEDG specifies the trigger condition to be either a positive or a negative edge. Finally, the register WKPND latches in the pending trigger conditions.

The GIE (Global Interrupt Enable) bit enables the interrupt function.

A control flag, LPEN, functions as a global interrupt enable for Port L interrupts. Setting the LPEN flag will enable interrupts and vice versa. A separate global pending flag is not needed since the register WKPND is adequate.

Since Port L is also used for waking the device out of the HALT or IDLE modes, the user can elect to exit the HALT or IDLE modes either with or without the interrupt enabled. If he elects to disable the interrupt, then the device will restart execution from the instruction immediately following the instruction that placed the microcontroller in the HALT or IDLE modes. In the other case, the device will first execute the interrupt service routine and then revert to normal operation. (See HALT MODE for clock option wakeup information.)

### INTERRUPT SUMMARY

The device uses the following types of interrupts, listed below in order of priority:

1. The Software Trap non-maskable interrupt, triggered by the INTR (00 opcode) instruction. The Software Trap is acknowledged immediately. This interrupt service routine can be interrupted only by another Software Trap. The Software Trap should end with two RPND instructions followed by a restart procedure.
2. Maskable interrupts, triggered by an on-chip peripheral block or an external device connected to the device. Under ordinary conditions, a maskable interrupt will not interrupt any other interrupt routine in progress. A maskable interrupt routine in progress can be interrupted by the non-maskable interrupt request. A maskable interrupt routine should end with an RETI instruction or, prior to restoring context, should return to execute the VIS instruction. This is particularly useful when exiting long interrupt service routines if the time between interrupts is short. In this case the RETI instruction would only be executed when the default VIS routine is reached.

## WATCHDOG

The device contains a WATCHDOG and clock monitor. The WATCHDOG is designed to detect the user program getting stuck in infinite loops resulting in loss of program control or “runaway” programs. The Clock Monitor is used to detect the absence of a clock or a very slow clock below a specified rate on the CKI pin.

The WATCHDOG consists of two independent logic blocks: WD UPPER and WD LOWER. WD UPPER establishes the upper limit on the service window and WD LOWER defines the lower limit of the service window.

Servicing the WATCHDOG consists of writing a specific value to a WATCHDOG Service Register named WDSVR which is memory mapped in the RAM. This value is composed of three fields, consisting of a 2-bit Window Select, a 5-bit Key Data field, and the 1-bit Clock Monitor Select field. Table 5 shows the WDSVR register.

**TABLE 5. WATCHDOG Service Register (WDSVR)**

Window Select		Key Data					Clock Monitor
X	X	0	1	1	0	0	Y
7	6	5	4	3	2	1	0

The lower limit of the service window is fixed at 2048 instruction cycles. Bits 7 and 6 of the WDSVR register allow the user to pick an upper limit of the service window.

Table 6 shows the four possible combinations of lower and upper limits for the WATCHDOG service window. This flexibility in choosing the WATCHDOG service window prevents any undue burden on the user software.

Bits 5, 4, 3, 2 and 1 of the WDSVR register represent the 5-bit Key Data field. The key data is fixed at 01100. Bit 0 of the WDSVR Register is the Clock Monitor Select bit.

**TABLE 6. WATCHDOG Service Window Select**

WDSVR Bit 7	WDSVR Bit 6	Clock Monitor	Service Window (Lower-Upper Limits)
0	0	x	2048–8k $t_c$ Cycles
0	1	x	2048–16k $t_c$ Cycles
1	0	x	2048–32k $t_c$ Cycles
1	1	x	2048–64k $t_c$ Cycles
x	x	0	Clock Monitor Disabled
x	x	1	Clock Monitor Enabled

### Clock Monitor

The Clock Monitor aboard the device can be selected or de-selected under program control. The Clock Monitor is guaranteed not to reject the clock if the instruction cycle clock ( $1/t_c$ ) is greater or equal to 10 kHz. This equates to a clock input rate on CKI of greater or equal to 100 kHz.

### WATCHDOG Operation

The WATCHDOG and Clock Monitor are disabled during reset. The device comes out of reset with the WATCHDOG armed, the WATCHDOG Window Select bits (bits 6, 7 of the WDSVR Register) set, and the Clock Monitor bit (bit 0 of the WDSVR Register) enabled. Thus, a Clock Monitor error will

occur after coming out of reset, if the instruction cycle clock frequency has not reached a minimum specified value, including the case where the oscillator fails to start.

The WDSVR register can be written to only once after reset and the key data (bits 5 through 1 of the WDSVR Register) must match to be a valid write. This write to the WDSVR register involves two irrevocable choices: (i) the selection of the WATCHDOG service window (ii) enabling or disabling of the Clock Monitor. Hence, the first write to WDSVR Register involves selecting or deselecting the Clock Monitor, select the WATCHDOG service window and match the WATCHDOG key data. Subsequent writes to the WDSVR register will compare the value being written by the user to the WATCHDOG service window value and the key data (bits 7 through 1) in the WDSVR Register. Table IV shows the sequence of events that can occur.

The user must service the WATCHDOG at least once before the upper limit of the service window expires. The WATCHDOG may not be serviced more than once in every lower limit of the service window. The user may service the WATCHDOG as many times as wished in the time period between the lower and upper limits of the service window. The first write to the WDSVR Register is also counted as a WATCHDOG service.

The WATCHDOG has an output pin associated with it. This is the WDOOUT pin, on pin 1 of the port G. WDOOUT is active low. The WDOOUT pin is in the high impedance state in the inactive state. Upon triggering the WATCHDOG, the logic will pull the WDOOUT (G1) pin low for an additional  $16 t_c - 32 t_c$  cycles after the signal level on WDOOUT pin goes below the lower Schmitt trigger threshold. After this delay, the device will stop forcing the WDOOUT output low.

The WATCHDOG service window will restart when the WDOOUT pin goes high. It is recommended that the user tie the WDOOUT pin back to  $V_{CC}$  through a resistor in order to pull WDOOUT high.

A WATCHDOG service while the WDOOUT signal is active will be ignored. The state of the WDOOUT pin is not guaranteed on reset, but if it powers up low then the WATCHDOG will time out and WDOOUT will enter high impedance state.

The Clock Monitor forces the G1 pin low upon detecting a clock frequency error. The Clock Monitor error will continue until the clock frequency has reached the minimum specified value, after which the G1 output will enter the high impedance TRI-STATE mode following  $16 t_c - 32 t_c$  clock cycles. The Clock Monitor generates a continual Clock Monitor error if the oscillator fails to start, or fails to reach the minimum specified frequency. The specification for the Clock Monitor is as follows:

$1/t_c > 10$  kHz — No clock rejection.

$1/t_c < 10$  Hz — Guaranteed clock rejection.

### WATCHDOG AND CLOCK MONITOR SUMMARY

The following salient points regarding the WATCHDOG and CLOCK MONITOR should be noted:

- Both the WATCHDOG and CLOCK MONITOR detector circuits are inhibited during RESET.
- Following RESET, the WATCHDOG and CLOCK MONITOR are both enabled, with the WATCHDOG having the maximum service window selected.
- The WATCHDOG service window and CLOCK MONITOR enable/disable option can only be changed once, during the initial WATCHDOG service following RESET.

## WATCHDOG Operation (Continued)

- The initial WATCHDOG service must match the key data value in the WATCHDOG Service register WDSVR in order to avoid a WATCHDOG error.
- Subsequent WATCHDOG services must match all three data fields in WDSVR in order to avoid WATCHDOG errors.
- The correct key data value cannot be read from the WATCHDOG Service register WDSVR. Any attempt to read this key data value of 01100 from WDSVR will read as key data value of all 0's.
- The WATCHDOG detector circuit is inhibited during both the HALT and IDLE modes.
- The CLOCK MONITOR detector circuit is active during both the HALT and IDLE modes. Consequently, the device inadvertently entering the HALT mode will be detected as a CLOCK MONITOR error (provided that the CLOCK MONITOR enable option has been selected by the program).
- With the single-pin R/C oscillator mask option selected and the CLKDLY bit reset, the WATCHDOG service window will resume following HALT mode from where it left off before entering the HALT mode.
- With the crystal oscillator mask option selected, or with the single-pin R/C oscillator mask option selected and the CLKDLY bit set, the WATCHDOG service window will be set to its selected value from WDSVR following HALT. Consequently, the WATCHDOG should not be serviced for at least 2048 instruction cycles following HALT, but must be serviced within the selected window to avoid a WATCHDOG error.
- The IDLE timer T0 is not initialized with RESET.
- The user can sync in to the IDLE counter cycle with an IDLE counter (T0) interrupt or by monitoring the TOPND flag. The TOPND flag is set whenever the thirteenth bit of the IDLE counter toggles (every 4096 instruction cycles). The user is responsible for resetting the TOPND flag.
- A hardware WATCHDOG service occurs just as the device exits the IDLE mode. Consequently, the WATCHDOG should not be serviced for at least 2048 instruction cycles following IDLE, but must be serviced within the selected window to avoid a WATCHDOG error.
- Following RESET, the initial WATCHDOG service (where the service window and the CLOCK MONITOR enable/disable must be selected) may be programmed anywhere within the maximum service window (65,536 instruction cycles) initialized by RESET. Note that this initial WATCHDOG service may be programmed within the initial 2048 instruction cycles without causing a WATCHDOG error.

## Detection of Illegal Conditions

The device can detect various illegal conditions resulting from coding errors, transient noise, power supply voltage drops, runaway programs, etc.

Reading of undefined ROM gets zeros. The opcode for software interrupt is zero. If the program fetches instructions from undefined ROM, this will force a software interrupt, thus signaling that an illegal condition has occurred.

The subroutine stack grows down for each call (jump to subroutine), interrupt, or PUSH, and grows up for each return or POP. The stack pointer is initialized to RAM location 06F Hex during reset. Consequently, if there are more returns than calls, the stack pointer will point to addresses 070 and 071 Hex (which are undefined RAM). Undefined RAM from addresses 070 to 07F (Segment 0), 140 to 17F (Segment 1), and all other segments (i.e., Segments 2 ... etc.) is read as all 1's, which in turn will cause the program to return to address 7FFF Hex. This is an undefined ROM location and the instruction fetched (all 0's) from this location will generate a software interrupt signaling an illegal condition.

Thus, the chip can detect the following illegal conditions:

1. Executing from undefined ROM
2. Over "POP"ing the stack by having more returns than calls.

When the software interrupt occurs, the user can re-initialize the stack pointer and do a recovery procedure before restarting (this recovery program is probably similar to that following reset, but might not contain the same program initialization procedures). The recovery program should reset the software interrupt pending bit using the RPND instruction.

## MICROWIRE/PLUS

MICROWIRE/PLUS is a serial synchronous communications interface. The MICROWIRE/PLUS capability enables the device to interface with any of National Semiconductor's MICROWIRE peripherals (i.e. A/D converters, display drivers, E<sup>2</sup>PROMs etc.) and with other microcontrollers which support the MICROWIRE interface. It consists of an 8-bit serial shift register (SIO) with serial data input (SI), serial data output (SO) and serial shift clock (SK). Figure 16 shows a block diagram of the MICROWIRE/PLUS logic.

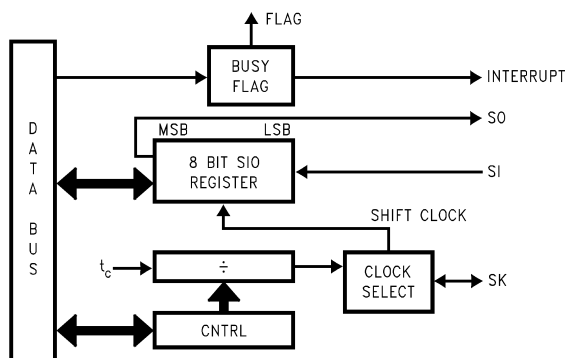

FIGURE 16. MICROWIRE/PLUS Block Diagram

The shift clock can be selected from either an internal source or an external source. Operating the MICROWIRE/PLUS arrangement with the internal clock source is called the Master mode of operation. Similarly, operating the MICROWIRE/PLUS arrangement with an external shift clock is called the Slave mode of operation.

The CNTRL register is used to configure and control the MICROWIRE/PLUS mode. To use the MICROWIRE/PLUS, the MSEL bit in the CNTRL register is set to one. In the master mode, the SK clock rate is selected by the two bits, SL0 and SL1, in the CNTRL register. details the different clock rates that may be selected.

**MICROWIRE/PLUS** (Continued)**TABLE 7. WATCHDOG Service Actions**

Key Data	Window Data	Clock Monitor	Action
Match	Match	Match	Valid Service: Restart Service Window
Don't Care	Mismatch	Don't Care	Error: Generate WATCHDOG Output
Mismatch	Don't Care	Don't Care	Error: Generate WATCHDOG Output
Don't Care	Don't Care	Mismatch	Error: Generate WATCHDOG Output

**TABLE 8. MICROWIRE/PLUS Master Mode Clock Select**

SL1	SL0	SK
0	0	2 x $t_c$
0	1	4 x $t_c$
1	x	8 x $t_c$

Where  $t_c$  is the instruction cycle clock

**MICROWIRE/PLUS OPERATION**

Setting the BUSY bit in the PSW register causes the MICROWIRE/PLUS to start shifting the data. It gets reset when eight data bits have been shifted. The user may reset the BUSY bit by software to allow less than 8 bits to shift. If enabled, an interrupt is generated when eight data bits have been shifted. The device may enter the MICROWIRE/PLUS mode either as a Master or as a Slave. *Figure 17* shows how two microcontroller devices and several peripherals may be interconnected using the MICROWIRE/PLUS arrangements.

**Warning:**

The SIO register should only be loaded when the SK clock is low. Loading the SIO register while the SK clock is high will result in undefined data in the SIO register. SK clock is normally low when not shifting.

Setting the BUSY flag when the input SK clock is high in the MICROWIRE/PLUS slave mode may cause the current SK clock for the SIO shift register to be narrow. For safety, the BUSY flag should only be set when the input SK clock is low.

**MICROWIRE/PLUS Master Mode Operation**

In the MICROWIRE/PLUS Master mode of operation the shift clock (SK) is generated internally by the device. The MICROWIRE Master always initiates all data exchanges. The MSEL bit in the CNTRL register must be set to enable the SO and SK functions onto the G Port. The SO and SK pins must also be selected as outputs by setting appropriate bits in the Port G configuration register. *Table 9* summarizes the bit settings required for Master mode of operation.

**MICROWIRE/PLUS Slave Mode Operation**

In the MICROWIRE/PLUS Slave mode of operation the SK clock is generated by an external source. Setting the MSEL bit in the CNTRL register enables the SO and SK functions

onto the G Port. The SK pin must be selected as an input and the SO pin is selected as an output pin by setting and re-setting the appropriate bits in the Port G configuration register. *Table 9* summarizes the settings required to enter the Slave mode of operation.

The user must set the BUSY flag immediately upon entering the Slave mode. This will ensure that all data bits sent by the Master will be shifted properly. After eight clock pulses the BUSY flag will be cleared and the sequence may be repeated.

**TABLE 9. MICROWIRE/PLUS Mode Settings**

This table assumes that the control flag MSEL is set.

G4 (SO) Config. Bit	G5 (SK) Config. Bit	G4 Fun.	G5 Fun.	Operation
1	1	SO	Int. SK	MICROWIRE/PLUS Master
0	1	TRI-STATE	Int. SK	MICROWIRE/PLUS Master
1	0	SO	Ext. SK	MICROWIRE/PLUS Slave
0	0	TRI-STATE	Ext. SK	MICROWIRE/PLUS Slave

**Alternate SK Phase Operation**

The device allows either the normal SK clock or an alternate phase SK clock to shift data in and out of the SIO register. In both the modes the SK is normally low. In the normal mode data is shifted in on the rising edge of the SK clock and the data is shifted out on the falling edge of the SK clock. The SIO register is shifted on each falling edge of the SK clock. In the alternate SK phase operation, data is shifted in on the falling edge of the SK clock and shifted out on the rising edge of the SK clock.

A control flag, SKSEL, allows either the normal SK clock or the alternate SK clock to be selected. Resetting SKSEL causes the MICROWIRE/PLUS logic to be clocked from the normal SK signal. Setting the SKSEL flag selects the alternate SK clock. The SKSEL is mapped into the G6 configuration bit. The SKSEL flag will power up in the reset condition, selecting the normal SK signal.



# MICROWIRE/PLUS (Continued)

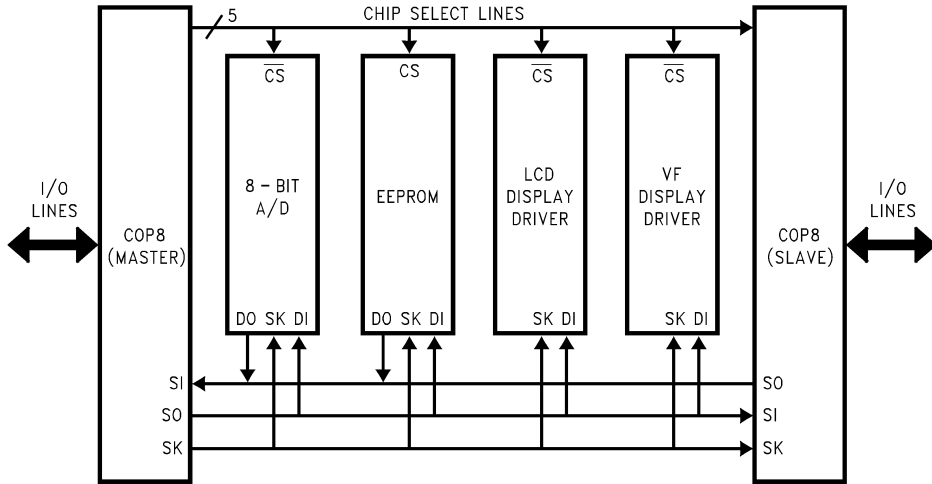

DS012094-17

FIGURE 17. MICROWIRE/PLUS Application

## Memory Map

All RAM, ports and registers (except A and PC) are mapped into data memory address space.

Address S/ADD REG	Contents
0000 to 006F	On-Chip RAM bytes (112 bytes)
0070 to 007F	Unused RAM Address Space (Reads As All Ones)
xx80 to xxAF	Unused RAM Address Space (Reads Undefined Data)
xxB0	Timer T3 Lower Byte
xxB1	Timer T3 Upper Byte
xxB2	Timer T3 Autoload Register T3RA Lower Byte
xxB3	Timer T3 Autoload Register T3RA Upper Byte
xxB4	Timer T3 Autoload Register T3RB Lower Byte
xxB5	Timer T3 Autoload Register T3RB Upper Byte
xxB6	Timer T3 Control Register
xxB7	Comparator Select Register (CMPSL)
xxB8 to xxBF	Reserved
xxC0	Timer T2 Lower Byte
xxC1	Timer T2 Upper Byte
xxC2	Timer T2 Autoload Register T2RA Lower Byte
xxC3	Timer T2 Autoload Register T2RA Upper Byte
xxC4	Timer T2 Autoload Register T2RB Lower Byte
xxC5	Timer T2 Autoload Register T2RB Upper Byte
xxC6	Timer T2 Control Register
xxC7	WATCHDOG Service Register (Reg:WDSVR)
xxC8	MIWU Edge Select Register (Reg:WKEDG)
xxC9	MIWU Enable Register (Reg:WKEN)
xxCA	MIWU Pending Register (Reg:WKPND)
xxCB	Reserved
xxCC	Reserved
xxCD to xxCF	Reserved

Address S/ADD REG	Contents
xxD0	Port L Data Register
xxD1	Port L Configuration Register
xxD2	Port L Input Pins (Read Only)
xxD3	Reserved for Port L
xxD4	Port G Data Register
xxD5	Port G Configuration Register
xxD6	Port G Input Pins (Read Only)
xxD7	Port I Input Pins (Read Only)
xxD8	Port C Data Register
xxD9	Port C Configuration Register
xxDA	Port C Input Pins (Read Only)
xxDB	Reserved for Port C
xxDC	Port D
xxDD to xxDF	Reserved
xxE0 to xxE5	Reserved
xxE6	Timer T1 Autoload Register T1RB Lower Byte
xxE7	Timer T1 Autoload Register T1RB Upper Byte
xxE8	ICNTRL Register
xxE9	MICROWIRE/PLUS Shift Register
xxEA	Timer T1 Lower Byte
xxEB	Timer T1 Upper Byte
xxEC	Timer T1 Autoload Register T1RA Lower Byte
xxED	Timer T1 Autoload Register T1RA Upper Byte
xxEE	CNTRL Control Register
xxEF	PSW Register
xxF0 to xxFB	On-Chip RAM Mapped as Registers
xxFC	X Register
xxFD	SP Register
xxFE	B Register
xxFF	S Register
0100 to 017F	On-Chip 128 RAM Bytes

Reading memory locations 0070H–007FH (Segment 0) will return all ones. Reading unused memory locations 0080H–00AFH (Segment 0) will return undefined data. Reading memory locations from other unused Segments (i.e., Segment 2, Segment 3, ... etc.) will return undefined data.

## Addressing Modes

There are ten addressing modes, six for operand addressing and four for transfer of control.

### OPERAND ADDRESSING MODES

#### Register Indirect

This is the “normal” addressing mode. The operand is the data memory addressed by the B pointer or X pointer.

#### Register Indirect (with auto post increment or decrement of pointer)

This addressing mode is used with the LD and X instructions. The operand is the data memory addressed by the B pointer or X pointer. This is a register indirect mode that automatically post increments or decrements the B or X register after executing the instruction.

#### Direct

The instruction contains an 8-bit address field that directly points to the data memory for the operand.

#### Immediate

The instruction contains an 8-bit immediate field as the operand.

#### Short Immediate

This addressing mode is used with the Load B Immediate instruction. The instruction contains a 4-bit immediate field as the operand.

#### Indirect

This addressing mode is used with the LAID instruction. The contents of the accumulator are used as a partial address (lower 8 bits of PC) for accessing a data operand from the program memory.

### TRANSFER OF CONTROL ADDRESSING MODES

#### Relative

This mode is used for the JP instruction, with the instruction field being added to the program counter to get the new program location. JP has a range from -31 to +32 to allow a 1-byte relative jump (JP + 1 is implemented by a NOP instruction). There are no “pages” when using JP, since all 15 bits of PC are used.

#### Absolute

This mode is used with the JMP and JSR instructions, with the instruction field of 12 bits replacing the lower 12 bits of the program counter (PC). This allows jumping to any location in the current 4k program memory segment.

#### Absolute Long

This mode is used with the JMPL and JSRL instructions, with the instruction field of 15 bits replacing the entire 15 bits of the program counter (PC). This allows jumping to any location in the current 4k program memory space.

#### Indirect

This mode is used with the JID instruction. The contents of the accumulator are used as a partial address (lower 8 bits of PC) for accessing a location in the program memory. The contents of this program memory location serve as a partial address (lower 8 bits of PC) for the jump to the next instruction.

**Note:** The VIS is a special case of the Indirect Transfer of Control addressing mode, where the double byte vector associated with the interrupt is transferred from adjacent addresses in the program memory into the program counter (PC) in order to jump to the associated interrupt service routine.

## Instruction Set

### Register and Symbol Definition

Registers	
A	8-Bit Accumulator Register
B	8-Bit Address Register
X	8-Bit Address Register
S	8-Bit Segment Register
SP	8-Bit Stack Pointer Register
PC	15-Bit Program Counter Register
PU	Upper 7 Bits of PC
PL	Lower 8 Bits of PC
C	1 Bit of PSW Register for Carry
HC	1 Bit of PSW Register for Half Carry
GIE	1 Bit of PSW Register for Global Interrupt Enable
VU	Interrupt Vector Upper Byte
VL	Interrupt Vector Lower Byte

Symbols	
[B]	Memory Indirectly Addressed by B Register
[X]	Memory Indirectly Addressed by X Register
MD	Direct Addressed Memory
Mem	Direct Addressed Memory or [B]
Meml	Direct Addressed Memory or [B] or Immediate Data
Imm	8-Bit Immediate Data
Reg	Register Memory: Addresses F0 to FF (Includes B, X and SP)
Bit	Bit Number (0 to 7)
←	Loaded with
↔	Exchanged with

## Instruction Set (Continued)

### INSTRUCTION SET

ADD	A,MemI	ADD	$A \leftarrow A + \text{MemI}$
ADC	A,MemI	ADD with Carry	$A \leftarrow A + \text{MemI} + C$ , $C \leftarrow \text{Carry}$
SUBC	A,MemI	Subtract with Carry	$A \leftarrow A - \text{MemI} + C$ , $C \leftarrow \text{Carry}$
AND	A,MemI	Logical AND	$A \leftarrow A \text{ and MemI}$
ANDSZ	A,Imm	Logical AND Immed., Skip if Zero	Skip next if $(A \text{ and Imm}) = 0$
OR	A,MemI	Logical OR	$A \leftarrow A \text{ or MemI}$
XOR	A,MemI	Logical EXclusive OR	$A \leftarrow A \text{ xor MemI}$
IFEQ	MD,Imm	IF Equal	Compare MD and Imm, Do next if $MD = \text{Imm}$
IFEQ	A,MemI	IF Equal	Compare A and MemI, Do next if $A = \text{MemI}$
IFNE	A,MemI	IF Not Equal	Compare A and MemI, Do next if $A \neq \text{MemI}$
IFGT	A,MemI	IF Greater Than	Compare A and MemI, Do next if $A > \text{MemI}$
IFBNE	#	If B Not Equal	Do next if lower 4 bits of $B \neq \text{Imm}$
DRSZ	Reg	Decrement Reg., Skip if Zero	$\text{Reg} \leftarrow \text{Reg} - 1$ , Skip if $\text{Reg} = 0$
SBIT	#,Mem	Set BIT	1 to bit, Mem (bit = 0 to 7 immediate)
RBIT	#,Mem	Reset BIT	0 to bit, Mem
IFBIT	#,Mem	IF BIT	If bit in A or Mem is true do next instruction
RPND		Reset PeNDing Flag	Reset Software Interrupt Pending Flag
X	A,Mem	EXchange A with Memory	$A \leftrightarrow \text{Mem}$
X	A,[X]	EXchange A with Memory [X]	$A \leftrightarrow [X]$
LD	A,MemI	LoaD A with Memory	$A \leftarrow \text{MemI}$
LD	A,[X]	LoaD A with Memory [X]	$A \leftarrow [X]$
LD	B,Imm	LoaD B with Immed.	$B \leftarrow \text{Imm}$
LD	Mem,Imm	LoaD Memory Immed	$\text{Mem} \leftarrow \text{Imm}$
LD	Reg,Imm	LoaD Register Memory Immed.	$\text{Reg} \leftarrow \text{Imm}$
X	A, [B ±]	EXchange A with Memory [B]	$A \leftrightarrow [B]$ , $(B \leftarrow B \pm 1)$
X	A, [X ±]	EXchange A with Memory [X]	$A \leftrightarrow [X]$ , $(X \leftarrow \pm 1)$
LD	A, [B±]	LoaD A with Memory [B]	$A \leftarrow [B]$ , $(B \leftarrow B \pm 1)$
LD	A, [X±]	LoaD A with Memory [X]	$A \leftarrow [X]$ , $(X \leftarrow X \pm 1)$
LD	[B±],Imm	LoaD Memory [B] Immed.	$[B] \leftarrow \text{Imm}$ , $(B \leftarrow B \pm 1)$
CLR	A	CLeaR A	$A \leftarrow 0$
INC	A	INCReament A	$A \leftarrow A + 1$
DEC	A	DECReament A	$A \leftarrow A - 1$
LAID		Load A InDirect from ROM	$A \leftarrow \text{ROM (PU,A)}$
DCOR	A	Decimal CORrect A	$A \leftarrow \text{BCD correction of A (follows ADC, SUBC)}$
RRC	A	Rotate A Right thru C	$C \rightarrow A7 \rightarrow \dots \rightarrow A0 \rightarrow C$
RLC	A	Rotate A Left thru C	$C \leftarrow A7 \leftarrow \dots \leftarrow A0 \leftarrow C$
SWAP	A	SWAP nibbles of A	$A7 \dots A4 \leftrightarrow A3 \dots A0$
SC		Set C	$C \leftarrow 1$ , $\text{HC} \leftarrow 1$
RC		Reset C	$C \leftarrow 0$ , $\text{HC} \leftarrow 0$
IFC		IF C	If C is true, do next instruction
IFNC		IF Not C	If C is not true, do next instruction
POP	A	POP the stack into A	$\text{SP} \leftarrow \text{SP} + 1$ , $A \leftarrow [\text{SP}]$
PUSH	A	PUSH A onto the stack	$[\text{SP}] \leftarrow A$ , $\text{SP} \leftarrow \text{SP} - 1$
VIS		Vector to Interrupt Service Routine	$\text{PU} \leftarrow [\text{VU}]$ , $\text{PL} \leftarrow [\text{VL}]$
JMPL	Addr.	Jump absolute Long	$\text{PC} \leftarrow ii$ (ii = 15 bits, 0 to 32k)
JMP	Addr.	Jump absolute	$\text{PC}9 \dots 0 \leftarrow i$ (i = 12 bits)
JP	Disp.	Jump relative short	$\text{PC} \leftarrow \text{PC} + r$ (r is -31 to +32, except 1)

**Instruction Set** (Continued)

JSRL	Addr.	Jump SubRoutine Long	$[SP] \leftarrow PL, [SP-1] \leftarrow PU, SP-2, PC \leftarrow ii$
JSR	Addr	Jump SubRoutine	$[SP] \leftarrow PL, [SP-1] \leftarrow PU, SP-2, PC \leftarrow 9 \dots 0 \leftarrow i$
JID		Jump InDirect	$PL \leftarrow ROM(PU, A)$
RET		RETurn from subroutine	$SP + 2, PL \leftarrow [SP], PU \leftarrow [SP-1]$
RETSK		RETurn and SKip	$SP + 2, PL \leftarrow [SP], PU \leftarrow [SP-1]$
RETI		RETurn from Interrupt	$SP + 2, PL \leftarrow [SP], PU \leftarrow [SP-1], GIE \leftarrow 1$
INTR		Generate an Interrupt	$[SP] \leftarrow PL, [SP-1] \leftarrow PU, SP-2, PC \leftarrow 0FF$
NOP		No OPERATION	$PC \leftarrow PC + 1$

## Instruction Set (Continued)

### Instruction Execution Time

Most instructions are single byte (with immediate addressing mode instructions taking two bytes).

Most single byte instructions take one cycle time to execute.

- Skipped instructions require x number of cycles to be skipped, where x equals the number of bytes in the skipped instruction opcode.

See the BYTES and CYCLES per INSTRUCTION table for details.

### Bytes and Cycles per Instruction

The following table shows the number of bytes and cycles for each instruction in the format of byte/cycle.

### Arithmetic and Logic Instructions

	[B]	Direct	Immed.
ADD	1/1	3/4	2/2
ADC	1/1	3/4	2/2
SUBC	1/1	3/4	2/2
AND	1/1	3/4	2/2
OR	1/1	3/4	2/2
XOR	1/1	3/4	2/2
IFEQ	1/1	3/4	2/2
IFNE	1/1	3/4	2/2
IFGT	1/1	3/4	2/2
IFBNE	1/1		
DRSZ		1/3	
SBIT	1/1	3/4	
RBIT	1/1	3/4	
IFBIT	1/1	3/4	
RPND	1/1		

### Instructions Using A & C

CLRA	1/1
INCA	1/1
DECA	1/1
LAI D	1/3
DCOR	1/1
RRCA	1/1
RLCA	1/1
SWAPA	1/1
SC	1/1
RC	1/1
IFC	1/1
IFNC	1/1
PUSHA	1/3
POPA	1/3
ANDSZ	2/2

### Transfer of Control Instructions

JMPL	3/4
JMP	2/3
JP	1/3
JSRL	3/5
JSR	2/5
JID	1/3
VIS	1/5
RET	1/5
RETSK	1/5
RETI	1/5
INTR	1/7
NOP	1/1

### Memory Transfer Instructions

	Register Indirect		Direct	Immed.	Register Indirect Auto Incr. & Decr.		
	[B]	[X]			[B+, B-]	[X+, X-]	
X A, (Note 29)	1/1	1/3	2/3		1/2	1/3	(IF B < 16) (IF B > 15)
LD A, (Note 29)	1/1	1/3	2/3	2/2	1/2	1/3	
LD B, Imm				1/1			
LD B, Imm				2/2			
LD Mem, Imm	2/2		3/3		2/2		
LD Reg, Imm			2/3				
IFEQ MD, Imm			3/3				

**Note 29:** Memory location addressed by B or X or directly.

# Opcode Table

Bits 7-4											Bits 3-0					
F	E	D	C	B	A	9	8	7	6	5	4	3	2	1	0	
JP-15	JP-31	LD 0F0, #i	DRSZ 0F0	RRCA	RC	ADC A, #i	ADC A <sub>i</sub> [B]	IFBIT 0, [B]	*	LD B, 0F	IFBNE 0	JSR 0000-00FF	JMP 0000-00FF	JP+17	INTR	
JP-14	JP-30	LD 0F1, #i	DRSZ 0F1	*	SC	SUBC A, #i	SUBC A <sub>i</sub> [B]	IFBIT 1, [B]	*	LD B, 0E	IFBNE 1	JSR 0100-01FF	JMP 0100-01FF	JP+18	JP+2	
JP-13	JP-29	LD 0F2, #i	DRSZ 0F2	X A <sub>i</sub> [X+]	X A <sub>i</sub> [B+]	IFEQ A, #i	IFEQ A <sub>i</sub> [B]	IFBIT 2, [B]	*	LD B, 0D	IFBNE 2	JSR 0200-02FF	JMP 0200-02FF	JP+19	JP+3	
JP-12	JP-28	LD 0F3, #i	DRSZ 0F3	X A <sub>i</sub> [X-]	X A <sub>i</sub> [B-]	IFGT A, #i	IFGT A <sub>i</sub> [B]	IFBIT 3, [B]	*	LD B, 0C	IFBNE 3	JSR 0300-03FF	JMP 0300-03FF	JP+20	JP+4	
JP-11	JP-27	LD 0F4, #i	DRSZ 0F4	*	LAID	ADD A, #i	ADD A <sub>i</sub> [B]	IFBIT 4, [B]	CLRA	LD B, 0B	IFBNE 4	JSR 0400-04FF	JMP 0400-04FF	JP+21	JP+5	
JP-10	JP-26	LD 0F5, #i	DRSZ 0F5	*	JID	AND A, #i	AND A <sub>i</sub> [B]	IFBIT 5, [B]	SWAPA	LD B, 0A	IFBNE 5	JSR 0500-05FF	JMP 0500-05FF	JP+22	JP+6	
JP-9	JP-25	LD 0F6, #i	DRSZ 0F6	X A <sub>i</sub> [X]	X A <sub>i</sub> [B]	XOR A, #i	XOR A <sub>i</sub> [B]	IFBIT 6, [B]	DCORA	LD B, 9	IFBNE 6	JSR 0600-06FF	JMP 0600-06FF	JP+23	JP+7	
JP-8	JP-24	LD 0F7, #i	DRSZ 0F7	*	*	OR A, #i	OR A <sub>i</sub> [B]	IFBIT 7, [B]	*	LD B, 8	IFBNE 7	JSR 0700-07FF	JMP 0700-07FF	JP+24	JP+8	
JP-7	JP-23	LD 0F8, #i	DRSZ 0F8	NOP	*	LD A, #i	IFC	SBIT 0, [B]	RBIT 0, [B]	LD B, 7	IFBNE 8	JSR 0800-08FF	JMP 0800-08FF	JP+25	JP+9	
JP-6	JP-22	LD 0F9, #i	DRSZ 0F9	*	*	*	IFNC	SBIT 1, [B]	RBIT 1, [B]	LD B, 6	IFBNE 9	JSR 0900-09FF	JMP 0900-09FF	JP+26	JP+10	
JP-5	JP-21	LD 0FA, #i	DRSZ 0FA	LD A <sub>i</sub> [X+]	LD A <sub>i</sub> [B+]	LD [B+], #i	INCA	SBIT 2, [B]	RBIT 2, [B]	LD B, 5	IFBNE 0A	JSR 0A00-0AFF	JMP 0A00-0AFF	JP+27	JP+11	
JP-4	JP-20	LD 0FB, #i	DRSZ 0FB	LD A <sub>i</sub> [X-]	LD A <sub>i</sub> [B-]	LD [B-], #i	DECA	SBIT 3, [B]	RBIT 3, [B]	LD B, 4	IFBNE 0B	JSR 0B00-0BFF	JMP 0B00-0BFF	JP+28	JP+12	
JP-3	JP-19	LD 0FC, #i	DRSZ 0FC	LD M <sub>d</sub> , #i	JMPL X A, M <sub>d</sub>	X A, M <sub>d</sub>	*	SBIT 4, [B]	RBIT 4, [B]	LD B, 3	IFBNE 0C	JSR 0C00-0CFF	JMP 0C00-0CFF	JP+29	JP+13	
JP-2	JP-18	LD 0FD, #i	DRSZ 0FD	DIR	JSRL	LD A, M <sub>d</sub>	RETSK	SBIT 5, [B]	RBIT 5, [B]	LD B, 2	IFBNE 0D	JSR 0D00-0DFF	JMP 0D00-0DFF	JP+30	JP+14	
JP-1	JP-17	LD 0FE, #i	DRSZ 0FE	LD A <sub>i</sub> [X]	LD A <sub>i</sub> [B]	LD [B], #i	RET	SBIT 6, [B]	RBIT 6, [B]	LD B, 1	IFBNE 0E	JSR 0E00-0EFF	JMP 0E00-0EFF	JP+31	JP+15	
JP-0	JP-16	LD 0FF, #i	DRSZ 0FF	*	*	*	RETI	SBIT 7, [B]	RBIT 7, [B]	LD B, 0	IFBNE 0F	JSR 0F00-0FFF	JMP 0F00-0FFF	JP+32	JP+16	

where,  
i is the immediate data  
M<sub>d</sub> is a directly addressed memory location  
\* is an unused opcode (see following table)

## Mask Options

The mask programmable options are shown below. The options are programmed at the same time as the ROM pattern submission.

```

OPTION 1: CLOCK CONFIGURATION
  = 1   Crystal Oscillator (CKI/10)
         G7 (CKO) is clock generator
         output to crystal/resonator
         CKI is the clock input
  = 2   Single-pin RC controlled
         oscillator (CKI/10)
         G7 is available as a HALT
         restart and/or general purpose
         input

OPTION 2: HALT
  = 1   Enable HALT mode
  = 2   Disable HALT mode

OPTION 3: BONDING OPTIONS
  = 1   44-Pin PLCC
  = 2   40-Pin DIP
  = 3   N/A
  = 4   28-Pin DIP
  = 5   28-Pin SO

```

## Development Support

### OVERVIEW

National is engaged with an international community of independent 3rd party vendors who provide hardware and software development tool support. Through National's interaction and guidance, these tools cooperate to form a choice of tools that fits each developer's needs.

This section provides a summary of the tool and development kits currently available. Up-to-date information, selection guides, free tools, demos, updates, and purchase information can be obtained at our web site at: [www.national.com/cop8](http://www.national.com/cop8).

### SUMMARY OF TOOLS

#### COP8 Evaluation Tools

- **COP8–NSEVAL:** Free Software Evaluation package for Windows. A fully integrated evaluation environment for COP8, including versions of WCOP8 IDE (Integrated Development Environment), COP8-NSASM, COP8-MLSIM, COP8C, DriveWay™ COP8, Manuals, and other COP8 information.
- **COP8 — NSASM:** Free COP8 Assembler v5 for Win32. Macro assembler, linker, and librarian for COP8 software development. Supports all COP8 devices. (DOS/Win16 v4.10.2 available with limited support).
- **COP8–MLSIM:** Free Instruction Level Simulator tool for Windows. For testing and debugging software instructions only (No I/O or interrupt support).
- **COP8–EPU:** Very Low cost COP8 Evaluation & Programming Unit. Windows based evaluation and hardware-simulation tool, with COP8 device programmer and erasable samples. Includes COP8-NSDEV, DriveWay COP8 Demo, MetaLink Debugger, I/O cables and power supply.
- **COP8–EVAL-ICUxx:** Very Low cost evaluation and design test board for COP8ACC and COP8SGx Families, from ICU. Real-time environment with add-on A/D, D/A, and EEPROM. Includes software routines and reference designs.

- **Manuals, Applications Notes, Literature:** Available free from our web site at: [www.national.com/cop8](http://www.national.com/cop8).

#### COP8 Integrated Software/Hardware Design Development Kits

- **COP8-EPU:** Very Low cost Evaluation & Programming Unit. Windows based development and hardware-simulation tool for COPSx/xG families, with COP8 device programmer and samples. Includes COP8-NSDEV, DriveWay COP8 Demo, MetaLink Debugger, cables and power supply.
- **COP8-DM:** Moderate cost Debug Module from MetaLink. A Windows based, real-time in-circuit emulation tool with COP8 device programmer. Includes COP8-NSDEV, DriveWay COP8 Demo, MetaLink Debugger, power supply, emulation cables and adapters.

#### COP8 Development Languages and Environments

- **COP8-NSASM:** Free COP8 Assembler v5 for Win32. Macro assembler, linker, and librarian for COP8 software development. Supports all COP8 devices. (DOS/Win16 v4.10.2 available with limited support). (Compatible with WCOP8 IDE, COP8C, and DriveWay COP8).
- **COP8-NSDEV:** Very low cost Software Development Package for Windows. An integrated development environment for COP8, including WCOP8 IDE, COP8-NSASM, COP8-MLSIM.
- **COP8C:** Moderately priced C Cross-Compiler and Code Development System from Byte Craft (no code limit). Includes BCLIDE (Byte Craft Limited Integrated Development Environment) for Win32, editor, optimizing C Cross-Compiler, macro cross assembler, BC-Linker, and MetaLink tools support. (DOS/SUN versions available; Compiler is installable under WCOP8 IDE; Compatible with DriveWay COP8).
- **EWCOP8-KS:** Very Low cost ANSI C-Compiler and Embedded Workbench from IAR (Kickstart version: COP8Sx/Fx only with 2k code limit; No FP). A fully integrated Win32 IDE, ANSI C-Compiler, macro assembler, editor, linker, Librarian, C-Spy simulator/debugger, PLUS MetaLink EPU/DM emulator support.
- **EWCOP8-AS:** Moderately priced COP8 Assembler and Embedded Workbench from IAR (no code limit). A fully integrated Win32 IDE, macro assembler, editor, linker, librarian, and C-Spy high-level simulator/debugger with I/O and interrupts support. (Upgradeable with optional C-Compiler and/or MetaLink Debugger/Emulator support).
- **EWCOP8-BL:** Moderately priced ANSI C-Compiler and Embedded Workbench from IAR (Baseline version: All COP8 devices; 4k code limit; no FP). A fully integrated Win32 IDE, ANSI C-Compiler, macro assembler, editor, linker, librarian, and C-Spy high-level simulator/debugger. (Upgradeable; CWOP8-M MetaLink tools interface support optional).
- **EWCOP8:** Full featured ANSI C-Compiler and Embedded Workbench for Windows from IAR (no code limit). A fully integrated Win32 IDE, ANSI C-Compiler, macro assembler, editor, linker, librarian, and C-Spy high-level simulator/debugger. (CWOP8-M MetaLink tools interface support optional).



## Development Support (Continued)

- **EW COP8-M:** Full featured ANSI C-Compiler and Embedded Workbench for Windows from IAR (no code limit). A fully integrated Win32 IDE, ANSI C-Compiler, macro assembler, editor, linker, librarian, C-Spy high-level simulator/debugger, PLUS MetaLink debugger/hardware interface (CW COP8-M).

### COP8 Productivity Enhancement Tools

- **WCOP8 IDE:** Very Low cost IDE (Integrated Development Environment) from KKD. Supports COP8C, COP8-NSASM, COP8-MLSIM, DriveWay COP8, and MetaLink debugger under a common Windows Project Management environment. Code development, debug, and emulation tools can be launched from the project window framework.
- **DriveWay-COP8:** Low cost COP8 Peripherals Code Generation tool from Aisys Corporation. Automatically generates tested and documented C or Assembly source code modules containing I/O drivers and interrupt handlers for each on-chip peripheral. Application specific code can be inserted for customization using the integrated editor. (Compatible with COP8-NSASM, COP8C, and WCOP8 IDE.)
- **COP8-UTILS:** Free set of COP8 assembly code examples, device drivers, and utilities to speed up code development.
- **COP8-MLSIM:** Free Instruction Level Simulator tool for Windows. For testing and debugging software instructions only (No I/O or interrupt support).

### COP8 Real-Time Emulation Tools

- **COP8-DM:** MetaLink Debug Module. A moderately priced real-time in-circuit emulation tool, with COP8 device programmer. Includes COP8-NSDEV, DriveWay COP8 Demo, MetaLink Debugger, power supply, emulation cables and adapters.
- **IM-COP8:** MetaLink iceMASTER®. A full featured, real-time in-circuit emulator for COP8 devices. Includes COP8-NSDEV, DriveWay COP8 Demo, MetaLink Windows Debugger, and power supply. Package-specific probes and surface mount adaptors are ordered separately.

### COP8 Device Programmer Support

- MetaLink's EPU and Debug Module include development device programming capability for COP8 devices.
- Third-party programmers and automatic handling equipment cover needs from engineering prototype and pilot production, to full production environments.
- Factory programming available for high-volume requirements.

## Development Support (Continued)

### TOOLS ORDERING NUMBERS FOR THE COP888EK FAMILY DEVICES

Vendor	Tools	Order Number	Cost	Notes
National	COP8-NSEVAL	COP8-NSEVAL	Free	Web site download
	COP8-NSASM	COP8-NSASM	Free	Included in EPU and DM. Web site download
	COP8-MLSIM	COP8-MLSIM	Free	Included in EPU and DM. Web site download
	COP8-NSDEV	COP8-NSDEV	VL	Included in EPU and DM. Order CD from website
	COP8-EPU	Not available for this device		
	COP8-DM	Contact MetaLink		
	Development Devices	COP87L84EK COP87L88EK	VL	16k OTP devices.
	IM-COP8	Contact MetaLink		
MetaLink	COP8-EPU	Not available for this device		
	COP8-DM	DM4-COP8-888EK (10 MHz), plus PS-10, plus DM-COP8/xxx (ie. 28D)	M	Included p/s (PS-10), target cable of choice (DIP or PLCC; i.e. DM-COP8/28D), 16/20/28/40 DIP/SO and 44 PLCC programming sockets. Add target adapter (if needed)
	DM Target Adapters	MHW-CNV39	L	DM target converters for 28SO
	IM-COP8	IM-COP8-AD-464 (-220) (10 MHz maximum)	H	Base unit 10 MHz; -220 = 220V; add probe card (required) and target adapter (if needed); included software and manuals
	IM Probe Card	PC-884EK28DW-AD-10	M	10 MHz 28 DIP probe card; 2.5V to 6.0V
		PC-888EK40DW-AD-10	M	10 MHz 40 DIP probe card; 2.5V to 6.0V
		PC-888EK44PW-AD-10	M	10 MHz 44 PLCC probe card; 2.5V to 6.0V
IM Probe Target Adapter	MHW-SOIC28	L	28 pin SOIC adapter for probe card	
ICU	COP8-EVAL	Not available for this device		
KKD	WCOP8-IDE	WCOP8-IDE	VL	Included in EPU and DM
IAR	EW COP8-xx	See summary above	L - H	Included all software and manuals
Byte Craft	COP8C	COP8C	M	Included all software and manuals
Aisys	DriveWay COP8	DriveWay COP8	L	Included all software and manuals
OTP Programmers		Contact vendors	L - H	For approved programmer listings and vendor information, go to our OTP support page at: <a href="http://www.national.com/cop8">www.national.com/cop8</a>
Cost: Free; VL =< \$100; L = \$100 - \$300; M = \$300 - \$1k; H = \$1k - \$3k; VH = \$3k - \$5k				

## Development Support (Continued)

### WHERE TO GET TOOLS

Tools are ordered directly from the following vendors. Please go to the vendor's web site for current listings of distributors.

Vendor	Home Office	Electronic Sites	Other Main Offices
Aisys	U.S.A.: Santa Clara, CA 1-408-327-8820 fax: 1-408-327-8830	www.aisysinc.com info@aisysinc.com	Distributors
Byte Craft	U.S.A. 1-519-888-6911 fax: 1-519-746-6751	www.bytecraft.com info@bytecraft.com	Distributors
Hilton	U.S.A.: Milford, PA	www.erols.com/sjg1/hilton.htm jhilton@warwick.net	
IAR	Sweden: Uppsala +46 18 16 78 00 fax: +46 18 16 78 38	www.iar.se info@iar.se info@iar.com info@iarsys.co.uk info@iar.de	U.S.A.: San Francisco 1-415-765-5500 fax: 1-415-765-5503 U.K.: London +44 171 924 33 34 fax: +44 171 924 53 41 Germany: Munich +49 89 470 6022 fax: +49 89 470 956
ICU	Sweden: Polygonvaegen +46 8 630 11 20 fax: +46 8 630 11 70	www.icu.se support@icu.se support@icu.ch	Switzerland: Hoehe +41 34 497 28 21
KKD	Denmark:	www.kkd.dk	
MetaLink	U.S.A.: Chandler, AZ 1-800-638-2423 fax: 1-602-926-1198	www.metaice.com sales@metaice.com support@metaice.com bbs: 1-602-962-0013 www.metalink.de	Germany: Kirchseeon 80-91-5696-0 fax: 80-91-2386 islander@metalink.de Distributors Worldwide
National	U.S.A.: Santa Clara, CA 1-800-272-9959 fax: 1-800-737-7018	www.national.com/cop8 support@nsc.com europe.support@nsc.com	Europe: +49 (0) 180 530 8585 fax: +49 (0) 180 530 8586 Distributors Worldwide

The following companies have approved COP8 programmers in a variety of configurations. Contact your local office or distributor. You can link to their web sites and get the latest listing of approved programmers from National's COP8 OTP Support page at: [www.national.com/cop8](http://www.national.com/cop8).

Advantech; Advin; BP Microsystems; Data I/O; Hi-Lo Systems; ICE Technology; Lloyd Research; Logical Devices; MQP; Needhams; Phytion; SMS; Stag Programmers; System General; Tribal Microsystems; Xeltek.

### Customer Support

Complete product information and technical support is available from National's customer responses centers, and from our on-line COP8 customer support sites.



**Physical Dimensions** inches (millimeters) unless otherwise noted (Continued)

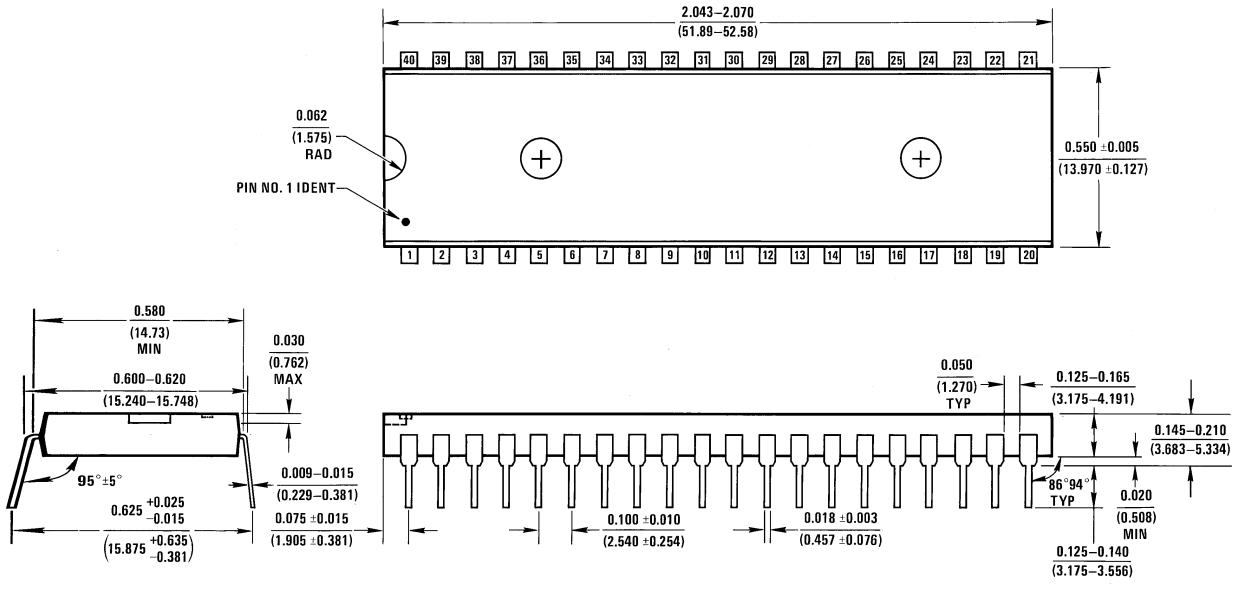

N40A (REV E)

**Molded Dual-In-Line Package (N)**  
 Order Number COP688EK-XXX/N, COP888EK-XXX/N,  
 COP988EK-XXX/N or COP988EKH-XXX/N  
 NS Package Number N40A

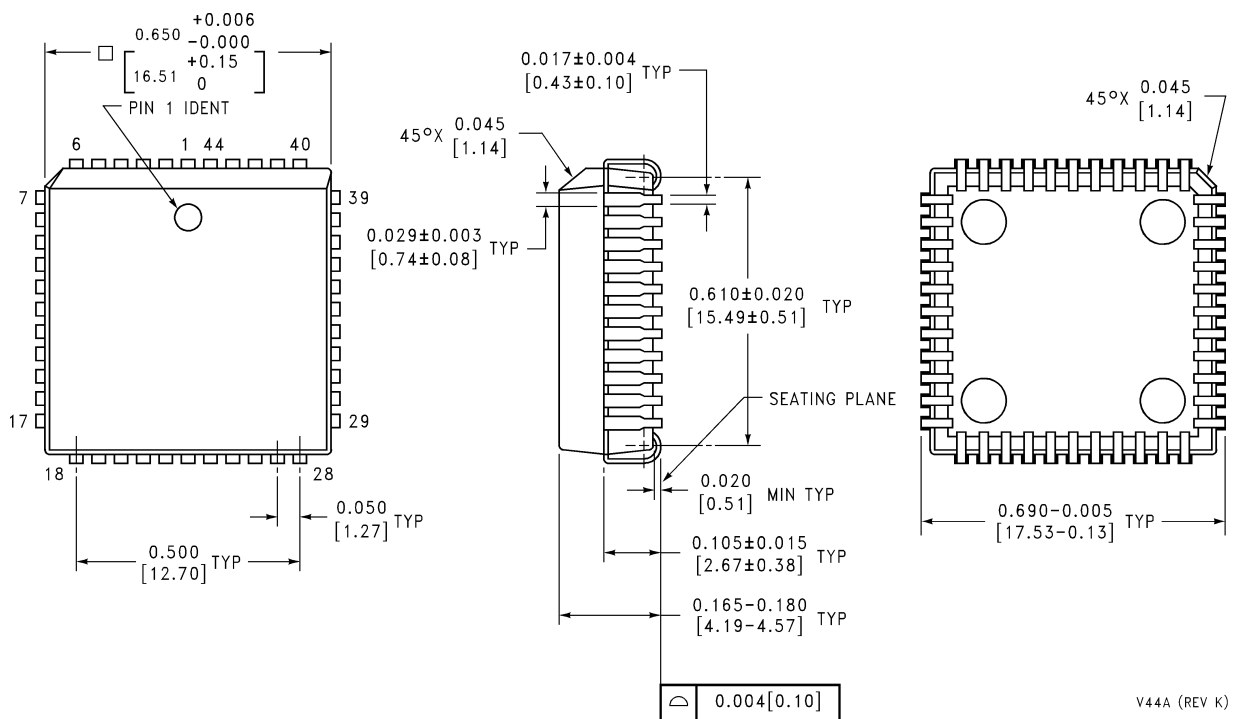

V44A (REV K)

**Plastic Leaded Chip Carrier (V)**  
 Order Number COP688EK-XXX/V, COP888EK-XXX/V,  
 COP988EK-XXX/V or COP988EKH-XXX/V  
 NS Package Number V44A

## Notes

### LIFE SUPPORT POLICY

NATIONAL'S PRODUCTS ARE NOT AUTHORIZED FOR USE AS CRITICAL COMPONENTS IN LIFE SUPPORT DEVICES OR SYSTEMS WITHOUT THE EXPRESS WRITTEN APPROVAL OF THE PRESIDENT AND GENERAL COUNSEL OF NATIONAL SEMICONDUCTOR CORPORATION. As used herein:

1. Life support devices or systems are devices or systems which, (a) are intended for surgical implant into the body, or (b) support or sustain life, and whose failure to perform when properly used in accordance with instructions for use provided in the labeling, can be reasonably expected to result in a significant injury to the user.
2. A critical component is any component of a life support device or system whose failure to perform can be reasonably expected to cause the failure of the life support device or system, or to affect its safety or effectiveness.



**National Semiconductor Corporation**  
Americas  
Tel: 1-800-272-9959  
Fax: 1-800-737-7018  
Email: support@nsc.com

[www.national.com](http://www.national.com)

**National Semiconductor Europe**  
Fax: +49 (0) 1 80-530 85 86  
Email: europe.support@nsc.com  
Deutsch Tel: +49 (0) 1 80-530 85 85  
English Tel: +49 (0) 1 80-532 78 32  
Français Tel: +49 (0) 1 80-532 93 58  
Italiano Tel: +49 (0) 1 80-534 16 80

**National Semiconductor Asia Pacific Customer Response Group**  
Tel: 65-2544466  
Fax: 65-2504466  
Email: sea.support@nsc.com

**National Semiconductor Japan Ltd.**  
Tel: 81-3-5639-7560  
Fax: 81-3-5639-7507