

17V(CPD200SX)

Color Computer Display Service Manual

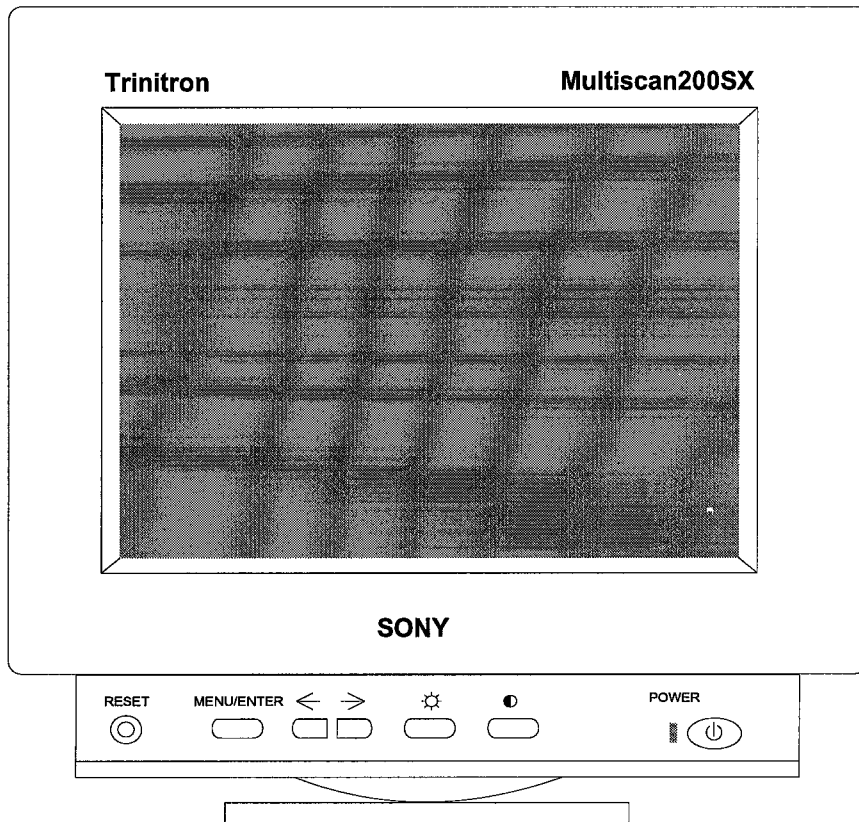

Table of Contents

Section 1.

Product Specification

1.1.Monitor Control Locations & Functions	1-1
1.2.Product Overview	1-2
1.3.CRT Characteristics	1-2
1.4.Power Specifications	1-2
1.4.1.Power Supply	1-2
1.4.2.Power Management	1-2
1.5.Video Specifications	1-2
1.5.1.Video Amplifier Performance	1-2
1.5.2.Video Input Signal Characteristics	1-2
1.6.Sync Input Signal Characteristics	1-2
1.6.1.Separate Sync	1-2
1.6.2.Composite Sync	1-2
1.6.3.Sync On Green	1-3
1.7.Environmental	1-3
1.7.1.Temperature/Humidity/Altitude	1-3
1.7.2.Vibration Test	1-3
1.7.3.Drop Test	1-3
1.8.Preset Timing Modes	1-3

Section 2.

Disassembly Instructions

2.1.Removing the Rear Cover	2-1
2.2.Internal Disassembly (Right side)	2-1
2.3.Internal Disassembly (Left Side)	2-1
2.4.Removing the Neck Board & Main Board	2-2

Section 3.

Theory of Operation

3.1.Switching Power Supply	3-1
3.1.1.Auto-degaussing	3-2
3.1.2.Suspend Mode Operation	3-2
3.2.The Deflection Circuit	3-2
3.2.1.IC301 LM1291 Video PLL System for Continuous-Sync	3-2
3.2.2.IC301 LM1291 Pin Descriptions	3-4
3.2.3.IC302 LM1295 DC Controlled Geometry Correction System	3-5
3.2.4.IC302 LM1295 Pin Descriptions	3-5
3.2.5.Vertical Deflection Circuit	3-6
3.2.6.Geometry Correction Circuit	3-7
3.2.7.Structure of Horizontal Deflection Circuit	3-7
3.2.8.X-RAY Protection Circuit	3-12
3.2.9.The Focus Circuit	3-12
3.2.10.Horizontal linearity and CS Switching	3-12
3.2.11.The Misconvergence Circuit	3-12

3.3.Video Amplifier	3-12
3.4.Microprocessor And Sync Processing	3-13

Section 4.

Setup Adjustments

4.1.Preparing the Display for Adjustment	4-1
4.1.1.Test Equipment Required	4-1
4.2.Adjustment Procedures	4-1
4.2.1.Adjustment Sequence	4-1
4.2.2.Preset Timings Used During Adjustment	4-1
4.3.High Voltage Verification	4-2
4.4.X-ray Protection Check	4-2
4.5.G1 Voltage Adjustment	4-2
4.6.Background Brightness Setting	4-2
4.7.Screen Brightness Adjustment	4-2
4.8.Magnetic Field Configuration	4-3
4.9.Raster Center Verification	4-3
4.10.Tilt Verification	4-3
4.11.Focus Verification	4-3
4.12.Color Misconvergence	4-3
4.13.Primary Test Mode Performance Adjustments	4-3
4.14.Performance Adjustments for All Preset Modes	4-3
4.15.Image Performance Verification	4-4
4.16.Uniformity Verification	4-4
4.17.Brightness Verification	4-4
4.18.Display Size Stability	4-4
4.19.Color Purity Verification	4-4
4.20.Video Noise	4-4
4.21.Power Saving Check	4-4
4.22.DDC 1/2 Data Writing	4-4

Section 5.

Troubleshooting

5.1.No Display at Power-on	5-1
5.2.No X-ray Operation	5-2
5.3.No Video Operation	5-3
5.4.Poor Vertical Linearity	5-4
5.5.Poor Horizontal Linearity	5-5
5.6.Poor Uniformity	5-6
5.7.Tilted Display Area	5-7
5.8.Misconvergence	5-8
5.9.Poor Regulation	5-9
5.10.Poor Focus	5-10
5.11.Poor Geometry Distortion	5-11

Section 6.

Printed Circuit Boards

6.1.Main Board	6-1
6.2.Neck Board	6-2

6.3.PCB Wiring Connection 6-3

Section 7.

Schematic Diagrams

7.1.Neck Circuit Diagram 7-1
7.2.MAIN Circuit Diagram 7-1

Section 8.

Replacement Parts

8.1.Exploded View 8-1
8.2.Key to Exploded View 8-2
8.3.Replacement Parts List 8-3

Notes

Section 1.

Product Specification

1.1.	Monitor Control Locations and Functions	1-1
1.2.	Product Overview	1-2
1.3.	CRT Characteristics	1-2
1.4.	Power Specifications	1-2
1.5.	Video Specifications	1-2
1.6.	Sync Input Signal Characteristics	1-2
1.7.	Environmental	1-3
1.8.	Preset Timing Modes	1-3

1.1. Monitor Control Locations & Functions

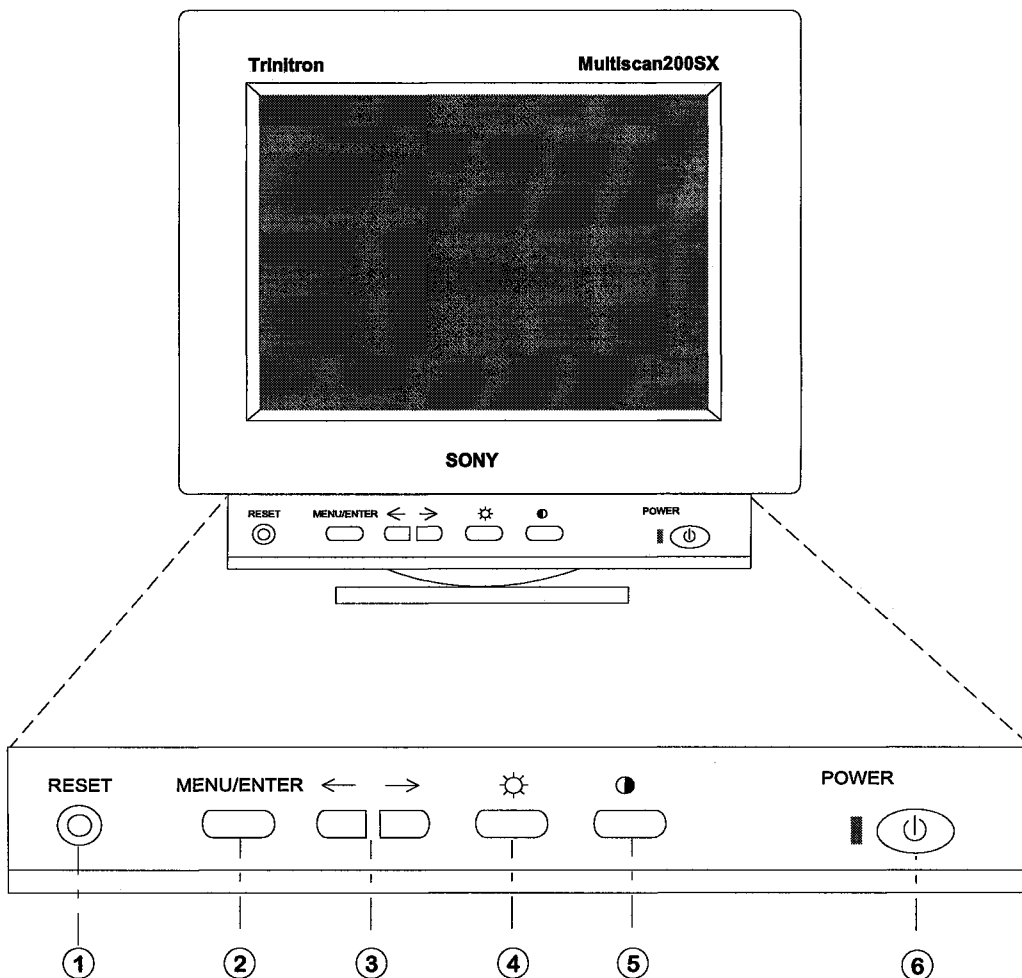

KEY TO MONITOR CONTROL FUNCTIONS		
(1)	Factory Setting Recall Function	Press to reset button for recall the original factory setting and press and hold for 3 seconds (minimum) to reset all modes to factory setting.
(2)	Push Button for OSD On/Off and Selection Confirm	Press to call up OSD functions onto screen and confirm the control button selection for OSD icon.
(3)	Control Button for Adjusting Setting and OSD Function Selection	Control button for adjusting the setting, left button for increasing and right button for decreasing and selection the OSD function icon.
(4)	Brightness Control Button	Increase/decrease raster black level using control button adjusting, left button for increasing and right button for decreasing.
(5)	Contrast Control Button	Increase/decrease video gain using control button adjusting, left button for increasing and right button for decreasing.
(6)	Power On/Off	Hard power On/Off button. Adjacent LED is lit when on. The LED color is green for normal condition and changes to orange for DPMS condition.

1.2. Product Overview

The monitor installed in the CPD-200SX (RMH 7T11/2/3) phom described in this service manual has the following features:

- 17 inches 0.26mm dot pitch conventional C.R.T
- 30~70kHz horizontal scanning
- 50~150kHz vertical refresh rate scanning
- 28 total memory modes in standard configuration
- Universal segmented auto range Power Supply
- VESA/NUTEK/EPA compliant power management

1.3. CRT Characteristics

- Screen Size 17 inches
- Faceplate Type Cylinder
- Phosphor Dot Pitch. 0.26mm, stripe pitch
- Electron Gun. 29mm, trinitron gun
- Deflection Angle 90 degree diagonal
- Shadow Mask. Aperture grille
- Phosphor Type P22
- Phosphor Persistence Medium Short
- Standard Light Transmission 42% Typical

1.4. Power Specifications

1.4.1. Power Supply

- A/C Receptacle. IEC320
- Power Supply Type Universal
- A/C Line Voltage Ranges .. 88VAC-132VAC
180VAC-264VAC
- A/C Line Frequency Ranges 50Hz/60Hz±3Hz
- Inrush Current. 30A/132V or
50A/264V (at cold start)
- Leakage Current ≤3.5mA
- Degauss. Automatic and Manual
(20 minutes for a full recovery)

1.4.2. Power Management

- Summary of operating states:

APM State	LED Color	Power Consumption	Automatic Recovery Time
On	Green	< 150W	Not applicable
Standby	Orange	< 30W	<3 seconds
Suspend	Orange	< 8W	<10 seconds
Off	Orange	< 8W	<10 seconds
Self test	Green	< 150W	Not applicable

- Signaling compliant with VESA DPMS guidelines
- Nutek 1992 guidelines Suspend < 30 watts,
off < 8 watts
- EPA Energy Star Standby < 30 watts

1.5. Video Specifications

1.5.1. Video Amplifier Performance

- Bandwidth (dot rate) 86MHz
- Typical 10%~90% rise and fall times.....calculation
9.0ns
- Video generator rise / fall times.....2ns maximum
- Scope and probe bandwidth. 350MHz minimum
- Probe capacitance. 2.5pf
- Overshoot / Undershoot. 10% maximum
- Sync on green. Amplitude : 714mV maximum
sync on green amplitude : 286mV maximum

1.5.2. Video Input Signal Characteristics

- Video Type. Analog
- Amplitude 700mV maximum
- Video Input Impedance 75 Ohms±1%
- Optional DDC 1/2B video Connector Pin Assignments:

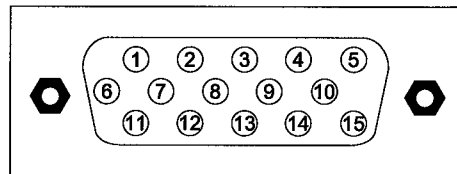

pin	Signal	pin	Signal	pin	Signal
1	Red video	6	Red return	11	Monitor GND
2	Green video	7	Green return	12	SDA
3	Blue video	8	Blue return	13	H. sync
4	Monitor GND	9	No pin	14	V.sync(VCLK)
5	No pin	10	Sync return	15	SCL

1.6. Sync Input Signal Characteristics

1.6.1. Separate Sync

- Sync Type TTL
- Amplitude 2.4V minimum
(Logic High), 0.8V max.(Logic Low)
- Polarity. Positive or Negative
- Equalization pulses Not allowed

1.6.2. Composite Sync

- Sync Type TTL
- Amplitude 2.4V minimum(Logic High)
0.8V max.(Logic Low)
- Polarity. Positive or Negative
- Serration pulses Allowed at horizontal rate

- Equalization pulses Not allowed

- Test Direction 1 Corner, 3 Edges, 6 Face

1.6.3. Sync On Green

- sync Type..... As per Apple
- Amplitude 0V minimum (Logic High)
-286mV max.(Logic Low)
- Polarity Negative/composite
- Serration pulses Allowed at horizontal rate
- Equalization pulses Not allowed

1.8. Preset Timing Modes

This display has 10 preset display modes configured during manufacture, given in the following table:

Model No.	Hf KHz	Vf Hz	Dot x Line
01	68.680	75.060	1152x870
02	68.677	84.997	1024x768
03	63.980	60.010	1280x1024
04	60.241	74.927	1024x768
05	60.023	75.029	1024x768
06	53.674	85.061	800x600
07	49.725	74.550	832x624
08	46.875	75.000	800x600
09	31.469	59.942	640x480
10	31.469	70.080	720x400

1.7. Environmental

1.7.1. Temperature/Humidity/Altitude

OPERATING :

- Temperature..... 10°C to 40°C
- Relative Humidity ... 0 to 90%,non-condensation
- Altitude 0 to 10,000 feet

NON-OPERATING :

- Temperature..... -40°C to +65°C
- Relative Humidity ... 0 to 95%,non-condensation
- Altitude 0 to 40,000 feet

1.7.2. Vibration Test

UNPACKED UNIT :

	Frequency	Amplitude	Acceleration(G)
1	5-22Hz	0.25mm	-
2	22-500Hz	-	0.25G

Times/Cycle:

- Rise Time..... 10 Minutes
- Fall Time 10 Minutes
- Number of Sweeps 1 Cycle
- Axis X,Y,Z
- Total Times 60 Minutes

PACKAGED UNIT :

	Frequency	Amplitude	Acceleration(G)
1	5-50Hz	-	0.83G
2	-	-	-

Times/Cycle:

- Rise Time..... 10 Minutes
- Fall Time 10 Minutes
- Number of Sweeps 1 Cycle
- Axis X,Y,Z
- Total Times 60 Minutes

1.7.3. Drop Test

- Compliant with NSTA Project 1A guidelines
- Drop Height..... 46cm

Section 2.

Disassembly Instructions

2.1.	Removing the Base and Rear Cover	2-1
2.2.	Internal Disassembly (Right Side).	2-1
2.3.	Internal Disassembly (Left Side)	2-1
2.4.	Removing the Neck Board and Main Board	2-2

2.1. Removing the Rear Cover

1. Remove the four screws at the rear cover. Refer to the figure 2-1 (A).
2. Remove the rear cover.

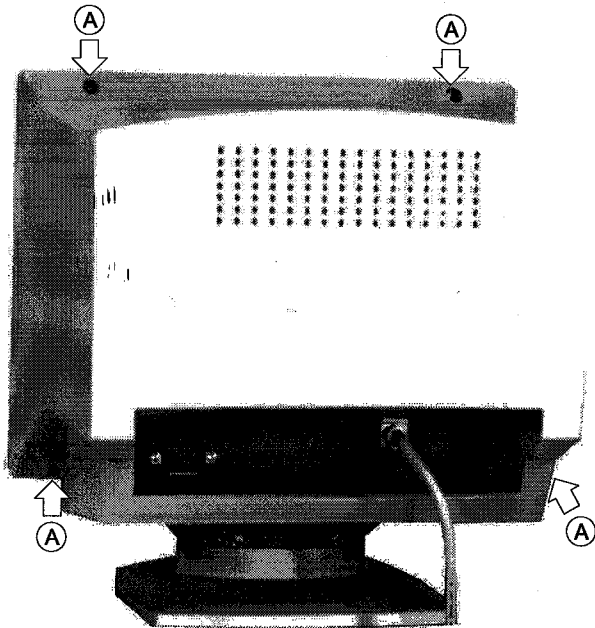

Figure 2-1 Remove the Base

2.2. Internal Disassembly (Right side)

The neck board is plugged on to the CRT neck and is enclosed in a metal shielding.

1. Disconnect the two ground wires from the neck shield. Refer to the figure 2-2 (A).
2. Disconnect the ground wire from the U bracket. Refer to the figure 2-2 (B).
3. Release the two cable wires to free the cable. Refer to the figure 2-2 (C).
4. Remove the three connected pins from the main board. Refer to the figure 2-2 (D).
5. Remove the two screws at the bezel. Refer to the figure 2-2 (E).
6. Remove the nylon revet holding from the bezel. Refer to the figure 2-2 (F).

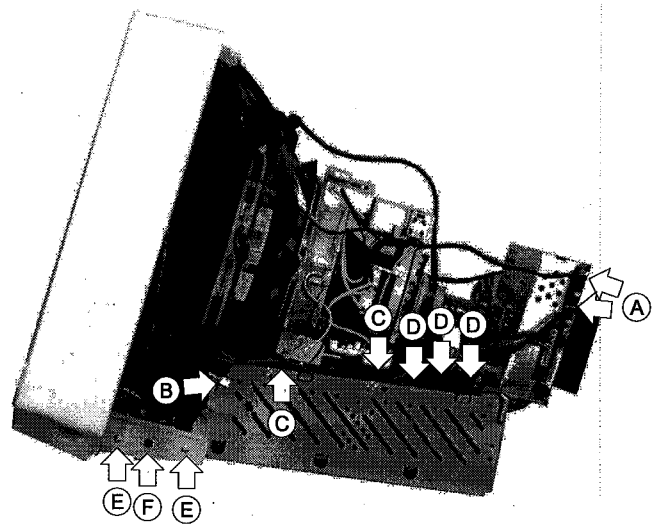

Figure 2-2 Remove the screws

2.3. Internal Disassembly (Left Side)

1. Disconnect the ground wire from the neck shield. Refer to the figure 2-3 (A).
2. Disconnect the ground wire from the U bracket. Refer to the figure 2-3 (B).
3. Remove the two connected pins from the main board. Refer to the figure 2-3 (C).
4. Remove the connected pin from the neck board. Refer to the figure 2-3 (D).

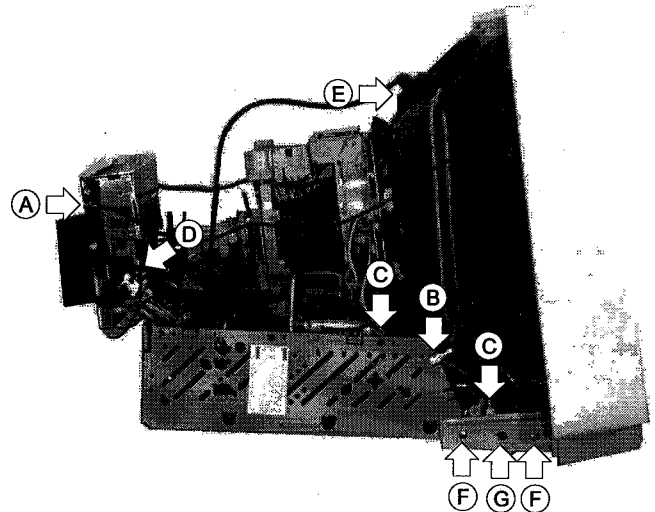

Figure 2-3 Remove the Rear Cover

IMPORTANT NOTE

To avoid risk of electric shock, before removing the anode cap, made sure the anode has been completely discharged as high voltage may remain on the anode for extended time after power off.

5. Remove the anode cap from the CRT. Refer to the figure 2-3 (E).
5. Remove the two screws at the bezel. Refer to the figure 2-3 (F).
6. Remove the nylon revet holding from the bezel. Refer to the figure 2-3 (G).

2.4. Removing the Neck Board & Main Board

1. Remove the three ground wires from the neck shield. Refer to the figure 2-4 (A).
2. Remove neck shield.
3. Remove Neck Board.
4. Remove the Main Board.

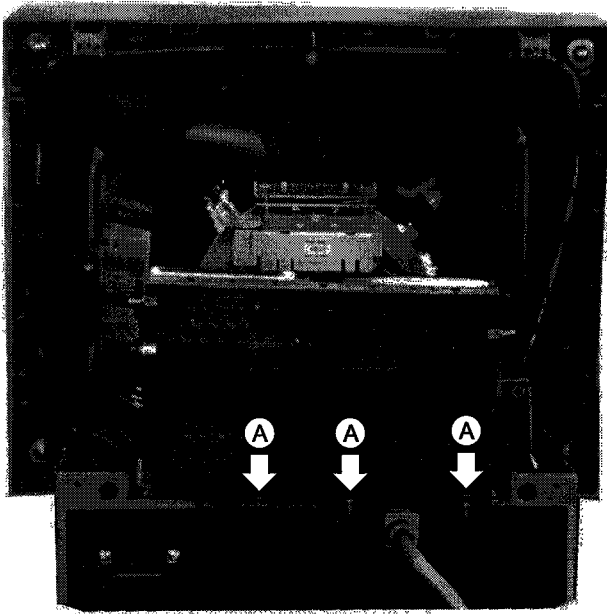

Figure 2-4 Internal Disassembly (Right Side)

Notes

Section 3.

Theory of Operation

3.1.	Switching Power Supply	3-1
3.2.	The Deflection Circuit	3-2
3.3.	Video Amplifier	3-12
3.4.	Microprocessor and Sync Processing.....	3-13

3.1. Switching Power Supply

The switching power supply (SPS) used in this display is a 150W flyback mode type. The power supply provides six outputs (177V, 75V, 15V, -12V, 6.3V and +5V). Please refer to schematic diagram for details of the circuit layout. The input voltage is from 88VAC — 264VAC with an input frequency of 47Hz — 63Hz. as shown in figure 3-1.

The current first passes through the EMI control circuit and is regulated to DC by the bridge diode (BD901) and filter capacitor (C907). During rectification a large current surge is generated and as C907 has a very low impedance while being charged the fuse, on/off switch and bridge diode are all liable to be damaged. For this reason, a thermal resistor (NTCR) is added before the bridge diode in order to limit the large current surge generated during the charging of the capacitor.

During rectification, C910 is charged through R903 and R904. When C910 is charged to 16V, IC901 3842A starts to operate (for details, of the functions of this IC, please refer to the relevant data sheet) and outputs a pulse signal from Pin 6 to set the transistor Q902 in the ON state. At this time, transformer T903, which is connected in parallel, starts to store power. When the current passing through the resistor R914, and the supplementary current from R957 and R964 into Pin 3 of IC901 reaches 1.1V, IC901 is reset, causing the energy stored by the transformer to reach the rated value. In order to prevent the transformer from being saturated and causing damage to the transistor, when transistor Q902 is in the OFF state, the energy stored in the transformer T903 is released into the secondary coil and is regulated through the various output loops and filters and converted to the required DC output. In addition to this, at the appropriate time, the windings pin1 — pin2 supply Pin 7 of IC901 with a fixed power supply for normal operation. Also, when windings pin2 — pin3 are in power saving active state, power is supplied to Pin 7 of IC901 for normal operation.

In any of the above cases, the output pulse is terminated and the FET is turned off, causing the voltage on the output of the FET to rise rapidly, and the voltage across the winding of the primary to reverse in polarity, thus tending to reset the flux within the core. At this point, the diodes D915, D925, D917-D920 and D926 on the secondary supply winding become forward biased and begin to conduct, thus transferring energy from primary to the secondary, and charging the secondary capacitors.

There is also secondary winding the primary side of the power supply which, through diode D908 and Q901 recharges the control IC901 reservoir capacitor C910. This supply then keeps the IC901 running. In the event of a secondary short circuit, the supply fails to recharge, thus the voltage across C910 drops to a threshold limit below which the IC901 cuts out and returns to its low current load operation.

During normal operation, the supply rails charge until the error amplifier realized by IC903 on the secondary begins to turn on the opto-coupler, PH901. At this point, the photo-transistor of this opto-coupler on the primary side begins to conduct, draining current from the primary control IC901 supply through diode D907 and D928.

Under normal operation IC903 regulates the current flow through PH901, and hence determines the output voltage of the error amplifier internal to IC901. Various passive components around IC903 and IC901 set the gain compensation for optimum stability and regulation characteristics.

In the event of a fault condition occurring, either Q904 may be turned on by the lack of voltage at pin2 of IC901 or zener diode ZD903 may conduct, due to excessive voltage on the primary IC901 supply. In the latter case, the triac Q903 will fire, thus dragging down the output of the control IC901 error amplifier, which in turn will limit the duty cycle and reduce the output voltage. It will stay in this mode until the AC input power is removed.

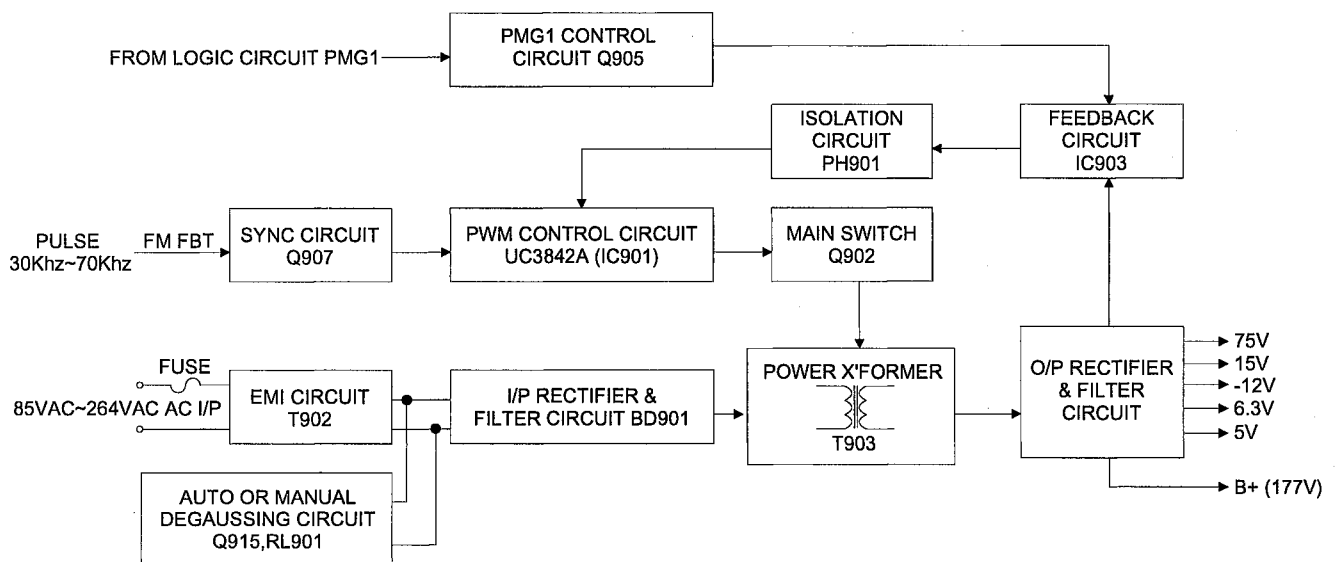

Figure 3-1 Switching Power Supply Block Diagram

When the feedback signal passing through the main 75V output is completed, the transistor's duty cycle is adjusted through the transfer to Pin 2 of IC901 3842A of the primary coil by PH901 4N35 and IC903 TL431, stabilizing the output current. At this time, it is important to note that before the feedback signal is established, the charge level of C917 cannot trigger Q903 SCR or it will cause a faulty power startup. In addition, in order to synchronize the supply power and monitor and reduce noise that will cause interference to the display, in the area D913 the monitor's feedback transformer gets a feedback signal in order to ensure synchronization between the power supply and monitor, with synchronization in the range 30kHz — 70kHz. Because the power operating frequency changes with the monitor causing changes in the value of IP, (the value of LP is fixed while the value of IP increase or decreases according to the frequency), this affects the test value of Pin 3 of IC901 3842A. This causes the total power supplied to vary according to the frequency, so a compensation value is provided by D914 in order to reduce the difference in total power for different frequencies. In addition, because the AC input ranges from 85VAC to 264VAC, this causes the value of the direct current on the DC bus to vary, affecting the rise rate of IP, the oscillator and the duty cycle, and causing the test value obtained at Pin 3 of IC901 to vary. To resolve this, a compensation value is provided by R964 and R957 which reduces the difference resulting from the different input voltages.

3.1.1. Auto-degaussing

When base of Q915 connector is in high state, the transistor Q915 2SC945P is on, causing the relay to jump from Normal Open (N.O.) to Normal Close (N.C.) to perform auto-degaussing operations. The duration of this operation is controlled by a logic pulse and lasts approximately 6 (six) seconds. When transistor Q915 enters the OFF state and the relay returns to N.O. to terminate the auto-degaussing operation is completed.

3.1.2. Suspend Mode Operation

Two feedback ratios can be selected, both sensing from the 75V rail. In the event of Q905 being turned on by micro processor, additional current is drawn from the virtual earth node of IC903, thus causing the power supply to serve the rail to a high voltage, nominally 75V. This is trimmed by resistor R937, R940 and R941. The other supply rail are predetermined ratios of this winging, being +15V, -12V, 6.3V and 177V nominally. In addition, a low voltage primary side winding feeds the control IC901 directly through D907 turning off the control IC901 supply through Q901, which would otherwise dissipate excessively.

When Q905 is turned off, the 75V rail drop to around 17V. In this case, the primary control supply fed through D907 drops to a value that is below the level needed to sustain operation. Instead, Q901 begins to conduct and the higher voltage supply winding taken

via D908 is used to keep the primary side powered up with minimal power losses.

The 5V power supply is driven by one of two sources. In normal operation when the 75V is present, the 5V regulator, IC902 is fed from the 15V rail through diode D921. When switched to standby mode (75V rail drops to 12V) then the 15V rail drops too low to supply IC902. In this case Q906 take over and maintains the supply to IC902 at around 9V.

In addition to the 5V regulated supply, in normal operation there is also a 15V regulated supply take from the 15V rail.

To ensure that micro processor gets a good 5V power supply, there is a power good detection circuit formed by Q801 and Q802. This monitors the supply going into the 5V rail (not the 5V rail directly). It detects whether there is sufficient voltage to enable the 5V regulator to work effectively. It is not a detection of the 5V rail itself, but relies upon the premise that the regulator is not faulty and that there is no faulty load condition on the 5V.

During power up, there is a delay to the signal at the output of the threshold comparator Q801 and Q802 a caused by ZD801 and C801, in order to allow the micro circuit time to stabilize. The threshold is chosen such that the RESET line drops low at least 25ms before the 5V drop out of regulation.

Finally a synchronization pulse taken from the horizontal output stage maintains the SMPS operating frequency in sync with the horizontal scan. D913 injects a pulse which prematurely triggers the oscillator within IC901 which would otherwise run at a frequency lower than the minimum required sync frequency.

3.2. The Deflection Circuit

Please refer to the block diagram of the deflection circuit and video circuit and Logic circuit as shown in figure 3-2.

3.2.1. IC301 LM1291 Video PLL System for Continuous-Sync

The LM1291 is an integrated horizontal time base solution specifically designed to operate in continuous-sync video monitors. It automatically synchronizes to any H frequency from 30kHz to 85kHz and provides the drive pulse to the high power deflection circuit.

Available sync processing includes a vertical sync separator and a composite video sync stripper. An internal sync selection scheme gives highest priority to separate H and V sync, then composite sync, and finally sync on video, no external switching between sync sources is necessary. The LM1291 provides polarity-normalized H/HV and V sync outputs, along with logic flags which show the respective input polarities.

The design uses an on-chip FVC (Frequency to Voltage Converter) to set the center frequency of the VCO

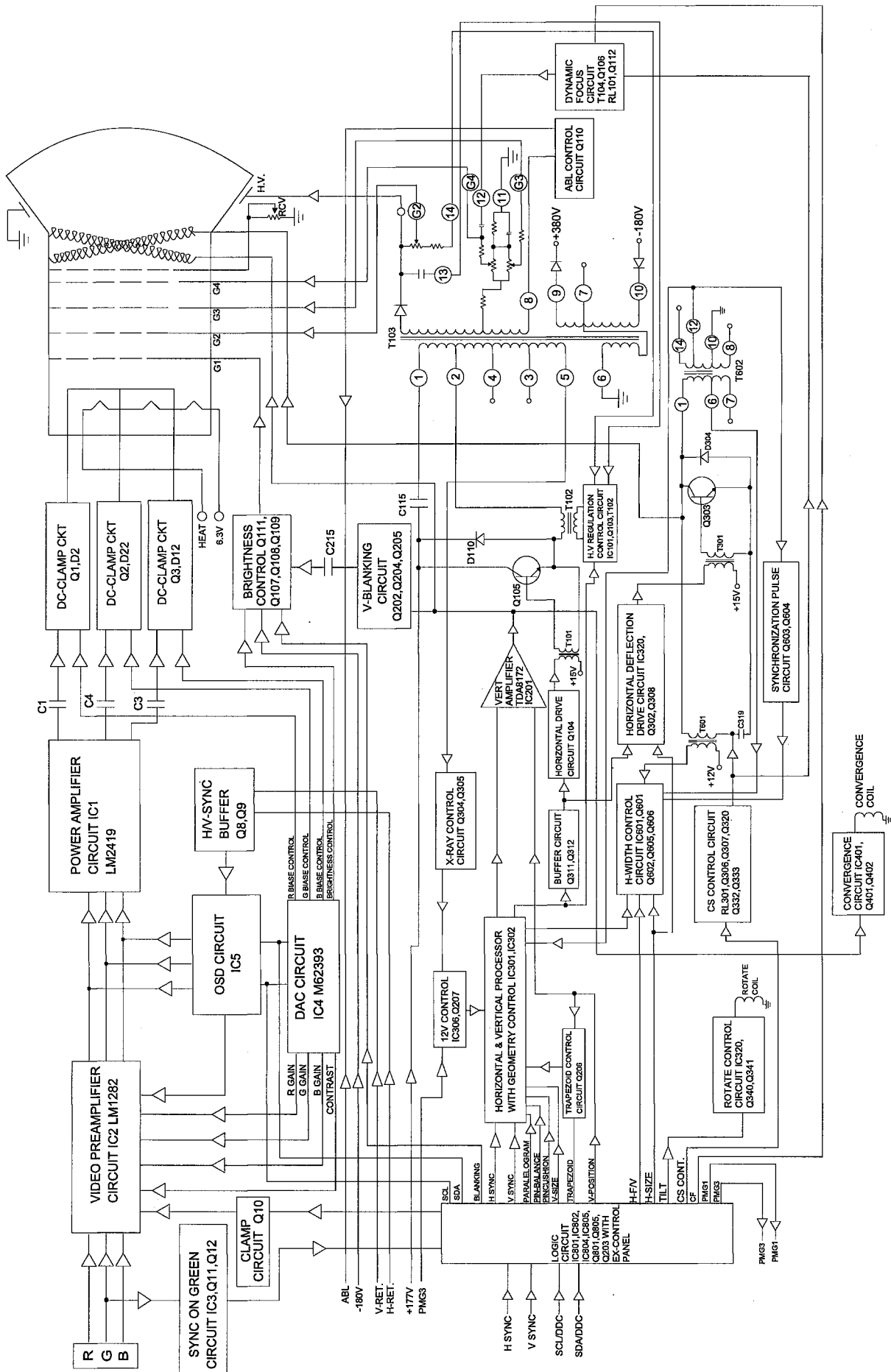

Figure 3-2 Video, Logic, Audio and Deflection Block Diagram

(Voltage Controlled Oscillator). This technique allows autosync operation over the entire frequency range using just one optimized set of external components.

The system includes a second phase detector which compensates for storage time variation in the horizontal output transistor, the picture's horizontal position is thus independent of temperature and component variance.

The LM1291 provides DC control pins for H drive duty cycle and flyback phase.

3.2.2. IC301 LM1291 Pin Descriptions

Pin 1 Clamp Control:

This low impedance current mode. When there is no H sync in sync-tip mode, the clamp pulse is generated by the VCO at the frequency preset by pin 5. This feature is intended for use in on screen display system.

Pin 2 Clamp pulse:

Active -low clamp pulse output.

Pin 3 Video Mute:

This open-collector output produces an active-low pulse when triggered by a step change of H sync frequency.

Pin 4 F-Max:

A resistor from this pin to ground sets the upper frequency limit of the VCO.

Pin 5 F-Min:

A resistor from this pin to ground sets the lower frequency limit of the VCO.

Pin 6 Voltage Refer CAP:

This is the decoupling pin for the internal 8.2V reference.

Pin 7 VCC:

12V nominal power supply pin.

Pin 8 Vertical Sync In:

This pin accepts AC-coupled vertical sync of either polarity.

Pin 9 Composite Video In:

The composite video sync stripper is active only when no signal is present at pin 12 (H/HV In). The signal to pin 9 must have negative going sync tips which are at least 0.14V below black level.

Pin 10 H/HV CAP:

A capacitor is connected from this pin to ground for detecting the polarity and existence of H/HV sync at pin 12.

Pin 11 H/HV Sync Out:

The sync processor outputs active-low H/HV sync derived from the active sync input (pin 9 or pin 12). Pin 11 stays low in the absence of sync input.

Pin 12 H/HV Sync In:

This pin accepts AC-coupled H or composite sync of either polarity.

Pin 13 H/HV Pol Out:

A low logic level indicates active-high H/HV sync to

pin 12, a high level indicates active-low. Pin 13 stays low in the absence of H/HV sync.

Pin 14 H Drive Duty Control:

A DC voltage applied to this pin sets the duty cycle of the horizontal drive output (pin 20). With a range of approximately 30%~70%. 2V sets the duty cycle to 50%.

Pin 15 H Drive EN:

A low logic level input enables H-Drive out (pin 20).

Pin 16 X-ray Shut Down:

This pin is for monitoring CRT anode voltage. If the input voltage exceeds an internal threshold, H-Drive out (pin 20) is latched high and video mute (pin 3) is latched low. Vcc has to be reduced to below approximately 2 V to clear the latched condition, i.e power must be turned off.

Pin 17 Vertical Sync Out:

The sync processor outputs active-low vertical sync derived from the active sync input (pin 8, pin 9 or pin 12). Pin 7 stays low in the absence of sync input.

Pin 18 Flyback In:

Input pin for phase detector 2. For best operation, the flyback peak should be at least 5 V but not greater than Vcc. A pulse width greater than 1.5 μ s is acceptable.

Pin 19 Vertical POL Out:

A low logic level indicates active-high vertical sync to pin 8, a high level indicates active-low. Pin 19 stays low in the absence of vertical sync.

Pin 20 Horizontal Drive Out:

This is an open-collector output which provides the drive pulse for the high power deflection circuit. The pulse duty cycle is controlled by pin 14.

Pin 21 Ground:

System ground. For best jitter performance, all LM1291 filter components and bypass capacitors should be connected to this pin via short paths.

Pin 22 Phase Detector 2 CAP:

The low-pass filter cap for the output of phase detector 2 is connected from this pin 21 (GND) via a short path.

Pin 23 Horizontal Drive Phase:

A AC control voltage applied to this pin sets the phase of the flyback pulse with respect to the leading edge of horizontal sync.

Pin 24 Vertical CAP:

A capacitor is connected from this pin to ground for detecting the polarity and existence of vertical sync at pin 8.

Pin 25 FVC CAP 2:

Secondary FVC filter pin. Cfvc 2 is connected from this pin to ground. The width of the video mute (pin 3) pulse is controlled by the time constant difference between the filter at pins 25 and 26.

Pin 26 FVC CAP 1:

Primary FVC filter pin. Cfvc 1 is connected from this

pin to pin 21 (GND) via a short path. The voltage at this pin is buffered to pin 27 (FVC out).

Pin 27 FVC Out:

Buffered output of the frequency-to-voltage converter, which sets the VCO center frequency through an external resistor to pin 28. Care should be taken when further loading this pin, since during the vertical interval it presents a high output impedance. Excessive loading can cause top-of-screen phase recovery problems.

Pin 28 PD 1 Out/VCO In:

Phase detector 1 has a gated charge pump output which requires an external low-pass filter. For best jitter performance, the filter should be ground to pin 21 (GND) via a short path. If a voltage source is applied to this pin, the phase detector is disabled and the VCO can be controlled directly.

3.2.3. IC302 LM1295 DC Controlled Geometry Correction System

The LM1295 is specifically designed for use in a continuous sync monitor. The injection-locked vertical oscillator operates from 50 Hz to 170 Hz, covering all known video monitors. A differential output current is provided in order to prevent ground interaction.

The IC302 provides two outputs composed of the summation of DC controlled 1st and 2nd order output terms. The first output corrects for EW pincushion and trapezoid. The second corrects for parallelogram and bow.

A DC controlled output is provided for vertical dynamic focus correction.

3.2.4. IC302 LM1295 Pin Descriptions

Pin 1 Ground:

This pin should be connected to the power ground at pin 17.

Pin 2 Vertical Height:

A Voltage between 0V and 4V on this pin controls the amplitude of the +V and -V drive currents, with increasing voltage giving increasing current. The control range is approximately 1.8 to 1. The response time is low, being limited by the automatic level control loop.

Pin 3 4V CAP:

A C202 capacitor aluminum electrolytic or tantalum, should be connected between pin 3 and GND to bypass the internal 4V reference.

Pin 4 Vertical Sync In:

The vertical sync input takes a negative-going TTL level pulse which injection locks the vertical oscillator to the vertical sync frequency if it is above the LM1295 minimum frequency. The minimum pulse width is approximately 200 μ s. For free-running detection (no vertical sync in), this input should be at logic high.

Pin 5 8V CAP:

A C203 capacitor, aluminum electrolytic or tantalum, should be connected between pin 5 and GND (pin 17) to bypass the internal 8V reference.

Pin 6 Vertical Dynamic Height:

A voltage between 3V and 4V on this pin controls the amplitude of the +V and -V drive currents with increasing voltage giving increasing current. The control range is approximately 1.3 to 1.

Pin 7 Vcc:

Vcc should be bypassed to GND (pin 17) with a C216 aluminum electrolytic or tantalum capacitor. The supply voltage is 12V.

Pin 8 Voltage Reference CAP:

A C217 capacitor aluminum electrolytic or tantalum, should be connected between pin 8 and GND (pin 17).

Pin 9 Horizontal Dynamic width:

This output consists of the sum of the vertical ramp and the parabola derived from the ramp. The amplitude and polarity of the ramp signal is DC controlled by horizontal trapezoid control (pin 11) and of the parabola by E-W pin control (pin 10). The weighting of the ramp is 1/3 the parabola; i.e., with the horizontal trapezoid and E-W pincushion controls at 4V, the output is 3 parts parabola and 1 part ramp. Horizontal dynamic width is used to correct for trapezoid and east-west pincushion distortion.

Pin 10 E-W Pincushion Control:

A voltage of 0V to 4V adjusts the polarity and the amount of parabola in the horizontal dynamic width (pin 9) output. At approximately 2V, the amount is zero. From 2V to 4V, the amplitude increases and the parabola is positive-going. From 2V to 0V, the amplitude increases and the parabola is negative-going.

Pin 11 Horizontal Trapezoid Control:

A voltage of 0V to 4V adjusts the polarity and the amount of vertical ramp in the horizontal dynamic width (pin 9) output. At approximately 2V, the amount is zero. From 2V to 4V, the amplitude increases and the ramp is positive-going. From 2V to 0V, the amplitude increases and the ramp is negative-going.

Pin 12 Horizontal parallelogram control:

A voltage of 0V to 4V adjusts the polarity and the amount of vertical ramp in the horizontal dynamic center (pin 14) output. At approximately 2V, the amount is zero. From 2V to 4V, the amplitude increases and the ramp is positive-going. From 2V to 0V, the amplitude increases and the ramp is negative-going.

Pin 13 Horizontal Bow Control:

A voltage of 0V to 4V adjusts the polarity and the amount of parabola in the horizontal dynamic center (pin 14) output. At approximately 2V, the amount is zero. From 2V to 4V, the amplitude increases and the parabola is positive-going. From 2V to 0V, the amplitude increases and the parabola is negative-going.

Pin 14 Horizontal Dynamic Center:

This output consists of the sum of the vertical ramp and the parabola derived from the ramp. The amplitude and polarity of the ramp signal is DC controlled by horizontal parallelogram control (pin 12) and of the parabola by horizontal bow control (pin 13). The difference between

this output and the horizontal dynamic width output is in the weighting of the ramp, which is equal to the parabola; i.e. with the horizontal parallelogram and horizontal bow controls at 4V, the output is 1 part parabola and 1 part ramp. Horizontal dynamic center is used to correct for parallelogram and bow distortion.

Pin 15 Vertical Dynamic Focus Control:

A voltage of 0V to 4V adjusts the polarity and the amount of parabola in the vertical dynamic focus (pin 16) output. At approximately 2V, the amount is zero. From 2V to 4V, the amplitude increases and the parabola is positive-going. From 2V to 0V, the amplitude increases and the parabola is negative-going..

Pin 16 Vertical Dynamic Focus:

This output consists of the parabola derived from the vertical ramp. The amplitude and polarity are controlled by vertical dynamic focus control.

Pin 17 Ground:

This is the power supply ground for the 12V supply and the point to which the bypass capacitors are returned.

Pin 18 Automatic Level Control CAP:

This capacitor (C204) is part of the level control circuit that maintains constant vertical height in spite of vertical sync frequency changes. If the VCO capacitor value is changed, the capacitor value should change in the same ratio. A R204 resistor should be connected from this pin to ground.

Pin 19 Double Frequency Capacitor:

This capacitor (C218) prevents the vertical oscillator from locking at twice the vertical sync frequency. If the VCO capacitor value is changed, this capacitor value should change in the same ratio.

Pin 20 Oscillator Capacitor:

This is the vertical oscillator capacitor (C232). The value can be changed to change the minimum frequency.

Pin 21 Vertical Resistor:

One end of the vertical resistor connects to this pin. This resistor determines the gain of the vertical ramp current generator. The gain is inversely proportional to the resistance.

Pin 22 Vertical Resistor:

The other end of the vertical resistor connects to this pin.

Pin 23 Vertical Drive:

This is the negative-going vertical ramp output current of the differential pair. The ramp current waveform is superimposed on a direct current of approximately 315 μ A. The waveform amplitude is determined by the vertical height (pin 2) control voltage and the vertical dynamic (pin 6) control voltage. The current can be converted into voltage by a R236 resistor to ground or by a differential amplifier using the differential currents as inputs. The voltage compliance of the output is typically 6V.

Pin 24 + Vertical Drive:

This is the same as vertical drive except it is the positive-going output current of the differential pair.

3.2.5. Vertical Deflection Circuit

1. IC201 TDA8172 consists of a flyback generator, voltage stabilizer, drive circuit and vertical output amplifier.
2. **The vertical oscillator circuit**

(a) The frequency and phase of the vertical oscillator circuit is generated by the vertical synchronization signal.

(b) The synchronization signal is input from Pin 4 of IC302 LM1295, and after being processed by the synchronization circuit, is sent to the vertical synchronization oscillator circuit to trigger the vertical oscillator and synchronize the oscillator frequency with the external synchronization signal. The frequency of its internal free oscillation is set by the time constant of C232. It does not need an external F/V control because this IC302 can keep vertical synchronization. Pin 18 provides vertical A.L.C function. So the pin 18 of IC302 is used to maintain the difference between the free oscillation frequency and external synchronization signal frequency at a similar level and make the sawtooth wave amplitude from pin 24 of IC302 the same.

3. **Vertical Size Control**

The pulse voltage output by the oscillator is sent to the sawtooth wave generator. The size and amplitude of the voltage of the sawtooth wave generation can be changed by DC value which output from Pin 35 of IC801 (PWM) and the vertical size can thus be controlled. This sawtooth wave voltage passes through a buffer and is output from Pin 24 of IC302 to pin 1 of IC201 TDA8172 of the vertical drive circuit.

The vertical ramp and DC offset are also controlled by PWM output. The vertical ramp generated across C232 is buffered internally to IC302 by DC controlled variable gain stage. The voltage level is derived from pin 35 of IC801 (PWM) through the R210, R206 and C206 of generation, then into pin 2 of IC302.

4. **Vertical Drive Circuit**

(a) It is not sufficient to rely solely on the oscillator circuit output to ensure the stability of the vertical output, so a first or second level amplifier circuit must be inserted between the oscillator circuit and the output. This circuit is called the drive amplifier and in addition to amplifying the sawtooth wave also corrects the vertical linearity.

After adding the drive circuit, because the level of amplification can be considerable, enough negative feedback can be added to correct vertical linearity and increase the stability of the circuit.

(b) If the current of the sawtooth wave flowing through the deflection yoke is distorted, then the top and bottom portions of the display will be expanded or compressed, resulting in poor linearity. In order to solve this problem, correction of the linearity of the sawtooth wave can be carried out before the drive level.

5. IC201 TDA8172 Vertical Drive Circuit

The IC201 uses a double power source, so it can be viewed as an OCL drive amplification circuit.

In order that the DC coupled output stage accurate DC reference, a DC reference voltage is taken from pin 5 of IC302. This used as the reference voltage (via divider resistors, R214 and R216) for the DC coupled power amplifier IC201. This is a simple voltage to current inverting amplifier, using R223 to derive a voltage proportional to the current in the deflection winding of the yoke. This voltage is fed back to the virtual signal earth inverting input of the power amplifier(pin1) by R219. This back to back diode feedback network modifies the linearity of the transfer characteristic in order to give precept "S" correction linearity, in addition to the variable correction in the ramp generator.

The vertical output amplifier has a voltage boost circuit to triple the positive supply voltage during retrace in order to speed up flyback. It does this by charging capacitor C210 through diode D202 during the normal forward scan. Pin6 of the IC201 is the voltage supply to the power output stage. When flyback occurs, pin3 is switched to the positive supply rail on pin2, thus adding the voltage across C210 to that of the supply rail, effective doubling the supply momentarily.

6. Vertical Centering Adjustment

Since IC201 functions as an OCL circuit, VDC is output from Pin 7 of IC201, so the central current can be changed to shift the on-screen display up or down to prevent voltage fluctuation. After adjusting the power stabilizer at Pin 5 of IC302 LM1295 (about 8V) and R214, R216 this is input to Pin 7 of IC201 to change the value of the vertical center.

The DC operating point of the amplifier can be varied by the pin 38 of IC801 (vertical position) output and via R212, C207 and R213 to pin 7 of IC201 which adds or subtracts an offset into

the output, thus varying the DC offset of the scan and hence the vertical centering.

3.2.6. Geometry Correction Circuit

1. If the width of the border in the center of the screen is insufficient, the waveform shown in Figure 3-3 below, can be used to add to horizontal deflection B+ in order to change the deflection of the horizontal deflection circuit. This waveform is the parabola obtained after regulation of the vertical period, and is created to perform amplitude modulation on the horizontal deflection current, as shown in Figure 3-4.

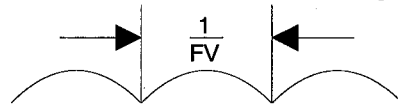

Figure 3-3 Voltage Correction Wave

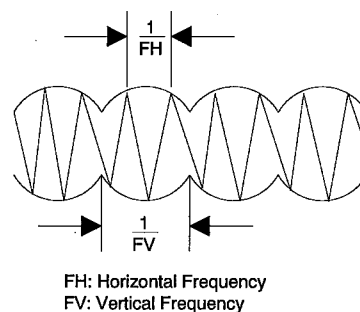

Figure 3-4 Current Correction Wave

2. The sawtooth wave is output from Pin 9 of IC302 and through C350 and R364 and input to Pin 2 of IC601 (DC to DC circuit). It is then output from Pin 6 of IC601 and after being sent to T603's second coil output, is added to horizontal B+ to provide pincushion and trapezoid distortion correction. So, is created to preform amplitude modulation on the horizontal deflection output pulse, as shown in figure 3-5.

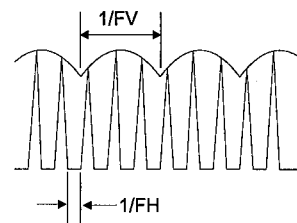

Figure 3-5 Collector of Q303 Output Pulse Correction Wave

3. The sawtooth wave is output from pin 14 of IC302 and through R353 and C314 and input to pin 23 of IC301. It is added to horizontal phase to provide parallelogram and bow distortion correction.

3.2.7. Structure of Horizontal Deflection Circuit

The function of the horizontal deflection circuit is to cause left/right scanning of the electron beam using

the sawtooth wave current flowing through the horizontal deflection yoke, and is made up of the horizontal oscillator circuit, horizontal drive circuit, horizontal output circuit, synchronous AFC circuit and high voltage generator circuit.

1. Horizontal Drive Amplifier

In order to rapidly saturate the output transistor (ON) or cut it off (OFF), a sufficient basic current must be provided. Because of this, an amplifier circuit is added between the oscillator circuit and the output circuit to amplify the pulse voltage. At the same time, after the waveform has been regulated, by adding this circuit to the output circuit, this amplification circuit functions as a drive amplifier.

IC301 LM1291 consists of a vertical sync selection polarity circuit, composite video sync stripper circuit, AFC circuit, H/V sync and composite sync circuit, voltage control oscillator circuit, phase regulator circuit, X-Ray circuit, video mute circuit, voltage regulator circuit and horizontal drive duty cycle circuit. This IC includes the vertical and horizontal circuits combined in one package.

When the synchronization signal input to logic circuit and pin 12 of IC301. The pin 20 of IC301 output horizontal frequency is achieved by the pin 1 of IC801 and flyback pulse from pin 12 of T602 (A.F.C) fed to pin 18 of IC301. So, the pin 20 of IC301 output horizontal frequency through Q311, Q312, Q302, Q104 T101 and T301 provide a horizontal output transistor base current of Q303 and horizontal anode voltage generator output transistor base current of Q105.

The horizontal output transistor base drive is taken from a conventional base drive transformer stage. This circuit as in a similar manner to a flyback power supply. The square wave horizontal oscillator output signal is coupled into the base of emitter drive stage transistor Q302, Q104, T301, T101 across the +15V supplies. This causes the primary current to increase linearly until such time as Q302 and Q104 turns off, hence storing a predetermined amount of flux energy in the transformer. As Q302 or Q104 turns off, and the primary current falls to zero, the secondary voltage is driven above the threshold of the base-emitter junction voltage of the horizontal output transistor Q303 or Q105. Current flows through R320, R321, L301, L302 and D303 into the base of Q303 or through R116, R150, L101 and D130 into the base of Q105 hence turning this device on. The high base current of around 1.1A. Lamps is so high that Q303 or Q105 is driven heavily into saturation. This is important in order that the collector voltage should be as low as low as possible whilst conducting the

high peak currents that flow through the horizontal deflection winding. In turn, this is vital to limit dissipation.

At the required time as determined by the horizontal oscillator, the base drive transistor is turned back on. The voltage at Q302 or Q104 collector fall rapidly back towards the ground rail. However, the secondary current still remains flowing in a positive direction for a short time, due to the finite leakage inductance of T301 or T101. Also, due to the heavy saturation of Q303 or Q105, the base voltage remains at around 1V. The current in the secondary winding rapidly reverses and goes sharply negative as the charge stored within the base region of Q303 or Q105 is removed. D303 or D130 helps to speed up this charge removal. Note that during this time, the collector output of the Q303 or Q105 is still turned on, even though the base current is flowing out of the base.

This period of time is known as the storage time of the device and may take between 2-3us, depending upon peak collector current and temperature and various other design factors. Finally, when all charge in the base region of Q303 or Q105 is dissipated the base current suddenly stops, and the secondary current drops almost instantly to zero. At that point, the device now become non conducting and the collector current flow also terminates. The secondary voltage on T301 or T101 drops to it's unloaded voltage and the current flow in the primary settles to it initial value once more.

2. Horizontal Equivalent Output Circuit

The horizontal output circuit uses the switch operation of a transistor and a damping diode, and provides a sawtooth wave current to the deflection yoke. The horizontal deflection yoke is made up of the L value on the coil and resistance r inside the coil connected in series. Its resistance is extremely small, and the time constant (L/r) is extremely large. Because of this the voltage at the two terminals of the coil cause rapid variation in the current flowing in the coil still will slowly vary, creating a sawtooth current. The basic circuit and equivalent circuit are shown in Figures 3-6 and 3-7.

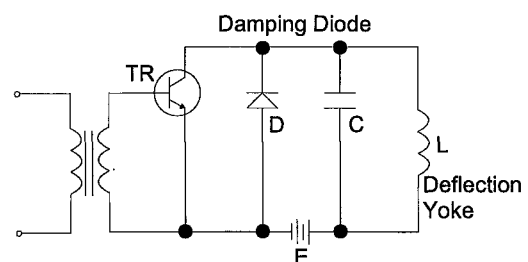

Figure 3-6 The Basic Deflection Circuit

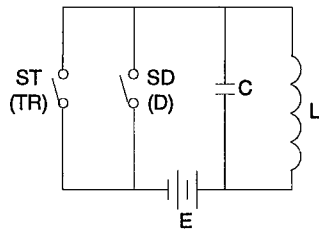

Figure 3-7 Equivalent Circuit

3. **Horizontal Output Equivalent Circuit Operation**

Refer to Figure 3-8 for the current wave of the voltage of the horizontal output circuit during operation.

(a) **t1 — t2 Period**

The base of the output transistor is added to the forward bias voltage. As the current through the base is very large, it will cause the output transistor to be saturated, corresponding to the ON state of S1 in the equivalent circuit. At this

time the deflection yoke contains a current flow and because the time constant is large, the current will slowly show a linear increase as shown in Figures 3-8 (b) and 3-9 (a).

(b) **t2-t3 Period**

At t2, a negative load is applied to the to the base and the output transistor changes to OFF (S1 in open state). There is no current passing through the transistor at this time and the L and C components of the deflection yoke become independent oscillation circuits. If the current is suddenly cut off, then the polarity of the inverse voltage generated at L will be as shown in Figure 3-9 (b). This voltage is viewed as the source voltage and will cause current to flow, at which time the current flowing to C is as shown in Figure 3-8 (d). At time t3 this current is 0 but the voltage at the two capacitor terminals is at maximum. This waveform is known as flyback pulse, and is shown in Figure 3-8 (f).

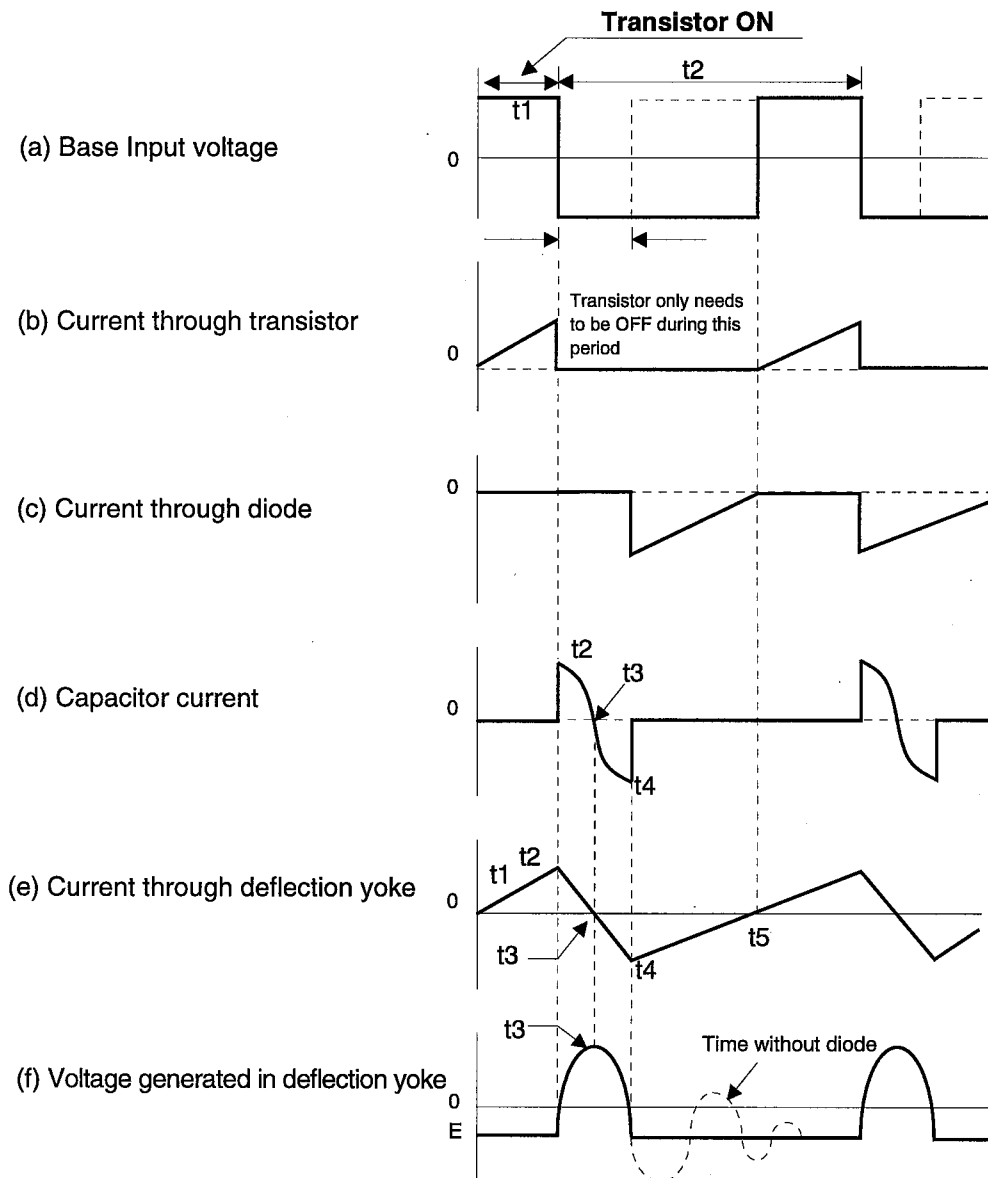

Figure 3-8 Horizontal Output Voltage/Current Waves

Section 4.

Setup Adjustments

4.1.	Preparing the Display for Adjustment	4-1
4.2.	Adjustment Procedures	4-1
4.3.	High Voltage Verification	4-2
4.4.	X-ray Protection Check	4-2
4.5.	G1 Voltage Adjustment	4-2
4.6.	Background Brightness Setting	4-2
4.7.	Screen Brightness Adjustment	4-2
4.8.	Magnetic Field Configuration	4-3
4.9.	Raster Center Verification	4-3
4.10.	Tilt Verification	4-3
4.11.	Focus Verification	4-3
4.12.	Color Misconvergence	4-3
4.13.	Primary Test Mode Performance Adjustment	4-3
4.14.	Performance Adjustments for All Preset Mode	4-3
4.15.	Image Performance Verifications	4-4
4.16.	Uniformity Verification	4-4
4.17.	Brightness Verification	4-4
4.18.	Display Size Stability	4-4
4.19.	Color Purity Verification	4-4
4.20.	Video Noise	4-4
4.21.	Power Saving Check	4-4
4.22.	DDC 1/2 Data Wiring	4-4

4.1. Preparing the Display for Adjustment

Before adjusting any the display settings or making final adjustments after service, perform the following pre-test settings to prepare the display for adjustment:

1. Be sure to allow the display to warm up for at least 30 minutes before making any adjustments.
2. When making tests and adjustments, the CRT should be facing east or west to minimize the affect of the earth's magnetic field.
3. Set the contrast control at 80% and the brightness control at 50% for all tests unless otherwise specified.
4. Thoroughly degauss the entire screen with a manual degausser before proceeding with tests.
5. All test should be performed with the rated power supply voltage unless otherwise specified.

4.1.1. Test Equipment Required

The following equipment will be required to make the tests and adjustments detailed in this section:

- Video signal and pattern generator
- Digital multimeter
- Degausser

4.2. Adjustment Procedures

4.2.1. Adjustment Sequence

This display undergoes an automatic alignment procedure during manufacture. This alignment procedure follows a fixed sequence of adjustments which are duplicated in this section. When making manual adjustments during service, you should always make the adjustments in the order given here to ensure correct results.

4.2.2. Preset Timings Used During Adjustment

During alignment it is necessary to input certian preset timings stored in the display. The detailed parameters of all the preset timings are given in the table below for your reference.

IMPORTANT NOTE

The preset timings for different versions of this model may differ from those shown here. Be sure to check the list of preset timings for the unit being serviced.

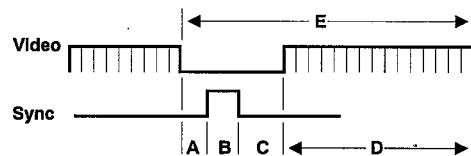

Mode Number	Mode 1	Mode 2	Mode 3	Mode 4	Mode 5	Mode 6	Mode 7	Mode 8	Mode 9	Mode 10
Data Pixel	1152	1024	1280	1024	1024	800	832	800	640	720
Data Line	870	768	1024	768	768	600	624	600	480	400
H. Freq.(kHz)	68.680	68.677	63.980	60.241	60.023	53.674	49.725	46.875	31.469	31.469
V. Freq(Hz)	75.060	84.997	60.010	74.927	75.029	85.061	74.550	75.000	59.942	70.080
Pixel Rate(MHz)	100.000	94.500	110.550	80.000	78.750	56.250	57.280	49.500	25.175	28.322
Hor. FP μ s(A)	0.320	0.508	0.434	0.400	0.203	0.569	0.559	0.323	0.636	0.636
Hor. Sync μ s(B)	1.280	1.016	1.737	1.200	1.219	1.138	1.117	1.616	3.813	3.813
Hor. BP μ s(C)	1.440	2.201	1.882	2.200	2.235	2.702	3.910	3.232	1.907	1.907
Hor. Active μ s(D)	11.520	10.836	11.578	12.800	13.003	14.222	14.524	16.162	25.422	25.422
Hor. Total μ s(E)	14.560	14.561	15.631	16.600	16.660	18.631	20.111	21.333	31.778	31.778
Ver. FP ms(A)	0.044	0.015	0.032	0.050	0.017	0.019	0.020	0.021	0.318	0.381
Ver. Sync ms(B)	0.044	0.044	0.063	0.050	0.050	0.056	0.060	0.064	0.064	0.064
Ver. BP ms(C)	0.568	0.524	0.563	0.498	0.466	0.503	0.784	0.448	1.048	1.112
Ver. Active ms(D)	12.667	11.183	16.006	12.749	12.795	11.179	12.549	12.800	15.253	12.711
Ver. Total ms(E)	13.322	11.765	16.663	13.347	13.328	11.756	13.413	13.333	16.683	14.269
Polarity(H.V)	-, -	+, +	+, +	-, -	+, +	+, +	-, -	+, +	-, -	-, +
Primary mode is 60.023kHz / 75.029Hz (1024x768)										

Table 4-1 Table of preset Timing Parameters

IMPORTANT NOTE

The adjustment settings in this section are based on REVISION C of the factory alignment procedures. Appendices detailing changes in the factory alignment procedures that have occurred since publication of this service manual are available upon request.

Initial settings to be carried out manually prior to automatic alignment:

4.3. High Voltage Verification

1. Input a cross hatch pattern in 68.68kHz (1152X870) mode and adjust VR101 on the main board (see figure 4-1 for approximate location) so the high voltage is in the range $27kV \pm 0.1$.
2. Input a full white pattern in 31.47kHz (640x480) mode, check that the high voltage is in the range $27kV \pm 0.2$.

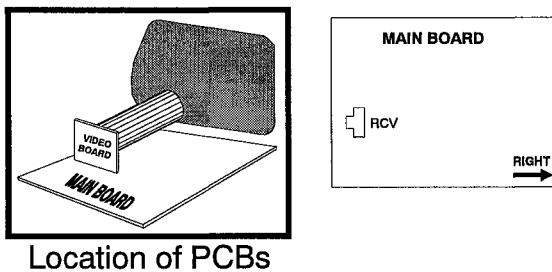

Location of PCBs

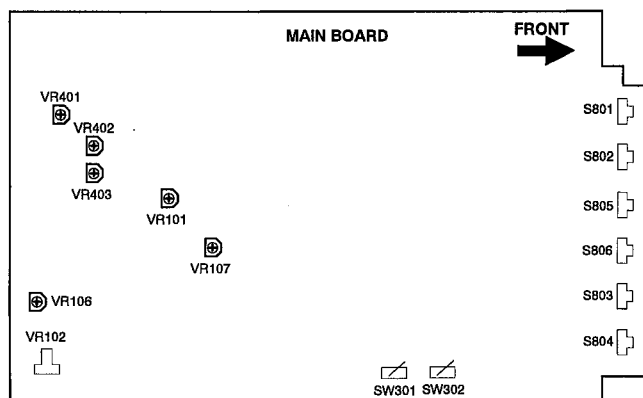

Figure 4-1 Location of on Mainboard & Neckboard

4.4. X-ray Protection Check

Input a cross hatch pattern in 68.68kHz (1152x870) mode, and use the 430kΩ resistor in parallel R103, then the X-ray protection circuit shall be operation.

4.5. G1 Voltage Adjustment

Input a raster pattern (video OFF) in primary mode and push the external brightness control button to maximum. Adjust

VR102 (see Figure 4-1 for approximate location) so that the voltage of G1 read on a digital multimeter is $-12V \pm 1$.

Steps used in white balance adjustment:

4.6. Background Brightness Setting

1. Input a raster pattern in primary mode and push the external brightness control button to maximum. Adjust the SCREEN VR so background brightness is approximately $0.8FL \pm 0.1$.
2. Before carrying out white balance adjustment, make sure that the display size and linearity are in spec.
3. Before carrying out white balance adjustment, make sure that the VR106 (see Figure 4-1 for approximate location) position shall be turn counterclockwise to the end (ABL no action).
4. Before carrying out white balance adjustment, make sure that the internal contrast VR107 (see Figure 4-1 for approximate location) shall be turn to the center position.
5. Input timing in primary mode, and the white balance automatic adjust some item as blow.
 - a) Input no video pattern in primary mode, and set-up brightness of raster white balance get the x,y value is $x=0.283 \pm 0.01$ $y=0.298 \pm 0.01$.
 - b) Input a full white pattern in primary mode, and set-up 9300 degrees kelvin of picture white balance get the x,y value is $x=0.283 \pm 0.01$ $y=0.298 \pm 0.01$.

4.7. Screen Brightness Adjustment

1. Input a raster pattern video off in primary mode. Set external brightness key to maximum and external contrast key to minimum, then make sure that the raster brightness range is $0.7FL \pm 0.2$. If not in this range, adjust screen VR of F.B.T.
2. Input a raster pattern in primary mode. Set external contrast key to maximum and push external brightness key to brightness is 0.007FL (cut OFF), then switch to a display of full white pattern and adjust internal contrast VR107 and check that brightness at the center of the screen is in the range $32FL \pm 1$.
3. Input a full white pattern in primary mode. Set external brightness and contrast key to maximum. Adjust VR106 and check that brightness at the center of the screen is in the range $40FL \pm 1$.

Conclusion White Balance Adjustment:

4.8. Magnetic Field Configuration

Configure the magnetic field as follows:

- Northern hemisphere : H=0.01, V=0.45
- Southern hemisphere : H=0.01, V=-0.52

4.9. Raster Center Verification

Input a cross hatch pattern in 68.68kHz (1125x870) mode, and check raster H-Center shall be less than 3mm ($|L-R| \leq 3\text{mm}$). If not in this ranged and select SW301 for adjustment raster H-center shall be less than 3mm, if not in this ranged again, please select SW302 for adjustment raster H-center in the specification.

4.10. Tilt Verification

Input a cross hatch pattern in primary mode and use the tilt rotation key to ensure that tilt is less than 1mm.

4.11. Focus Verification

1. Input a full white pattern in primary mode. Use the external brightness control to adjust background brightness so it is not visible and set external contrast so the brightness is 30FL, then switch to a display of cross hatch pattern.
2. Adjust the FBT focus VR1 and VR2 so the vertical line and horizontal line are as clear as possible.
3. Input a "o" characters pattern in primary mode and check "o" characters is clearest.

4.12. Color Misconvergence

1. Input a full white pattern in primary mode and adjust external brightness so there is no background brightness and external contrast so the screen brightness is 30FL.
2. Switch to a cross hatch pattern and verify that misconvergence in a circle measured from the center of the screen (Area A) is not greater than 0.3mm, and for all areas outside Area A is not greater than 0.4mm.
3. If not in the specification, as following as below items.
 - a) Input a cross hatch pattern in primary mode. Adjust RCV (see Figure 4-1 for approximate location) get the color convergence of vertical line is in the most excellent way.
 - b) Input a cross hatch pattern in primary mode. Adjust VR403 (see Figure 4-1 for approximate location) get the color convergence of center horizontal line is in the most excellent way.
 - c) Input a cross hatch pattern in primary mode. Adjust VR402 and VR401 (see Figure 4-1 for approximate location) get the color conver-

gence of top and bottom horizontal line is in the most excellent way.

- d) After used the magnetic in a four corner adjustments for arrive to better color convergence.

Automatic camera alignment procedure:

The procedures listed below are those carried out using the automatic Camera Alignment System (CAS). These adjustments cannot be made manually but must be performed using the CAS software provided by the manufacturer.

4.13. Primary Test Mode Performance Adjustments

1. **V. RASTER CENTERING**
Raster area centered vertically in the bezel.
2. **ROTATION (TILT)**
Raster area aligned with bezel.

4.14. Performance Adjustments for All Preset Modes

1. **H POSITION**
Centers the picture display horizontally in the bezel area ($|L-R| \leq 1\text{mm}$).
2. **H SIZE**
Configures picture display width as $300 \pm 3\text{mm}$.
3. **V POSITION**
Centers the picture display vertically in the bezel area ($|T-B| \leq 1\text{mm}$).
4. **V SIZE**
Configures picture display height as $225 \pm 3\text{mm}$.
5. **V Linearity**
Configures vertical linearity as less than 8%.
6. **Rotation**
Configures picture display rotation as less than 1mm.
7. **Pin-Balance**
Sets left and right pin-balance distortion to less than 1.5mm.
8. **PINCUSHION**
Sets left and right pincushion distortion to less than 1.5mm.
9. **Trapezium**
Sets upper and lower trapezium distortion to less than 1.5mm.
10. **Parallelogram**
Sets parallelogram distortion to less than 1.5mm.

Conclusion of automatic alignment:

4.15. Image Performance Verification

Input each of the preset timings and check that the following specifications are met:

1. **Horizontal Position**
|L-R| ≤ 3mm
2. **Horizontal Size**
300 ± 3mm
3. **Vertical Position**
|T-B| ≤ 3mm
4. **Vertical Size**
225 ± 3mm
5. **Horizontal Linearity**
H ≤ 10% (10 x 8 cross hatch pattern)
This calculation is based on the following formula:
$$\frac{Max - Min}{Max} \times 100\% \leq 10\%$$
6. **Vertical Linearity**
V ≤ 8.0% (10x8 cross hatch pattern).
$$\frac{Max - Min}{Max} \times 100\% \leq 8\%$$
7. **Geometric Edge Distortion**
All geometrics distortion shall be less than as below:
Horizontal line ≤ 2.5mm
Vertical line ≤ 2mm
8. **Recall Button Function**
Adjust H/V phase and size at random using the external controls and press the recall button. Check that the image performance has returned to be in spec, which will indicate the recall button is functioning correctly.

4.16. Uniformity Verification

Input a 2" square pattern in primary mode, set contrast to maximum and check that there is no overshoot. Check that the brightness in the four corners of the screen is not less than 70% of that in the center of the screen.

4.17. Brightness Verification

1. Input a raster pattern (no video pattern) in primary mode. Adjust external brightness to 0.007FL (cut OFF).
2. Input a full white pattern and adjust external contrast to maximum then check that brightness at the center of the screen shall be more than 30FL. Adjust external contrast to minimum and check that brightness at the center of the screen is between 1.5FL~4.5FL.
3. Input a 2" square pattern in primary mode, and adjust external contrast to maximum then check that brightness at the center of the screen is between 30FL~38FL.

4.18. Display Size Stability

Input a full white pattern in primary mode, set external brightness at 5FL and measure the display size. Adjust the brightness to 30FL and remeasure the display size. The difference should be less than 0.8mm.

4.19. Color Purity Verification

1. Input a full white pattern in primary mode and adjust external brightness so there is no background brightness and adjust external contrast to 25FL. Make a visual check of color purity as follows:
 - a) Input the red (R) signal only; no green (G) or blue (B) should be visible.
 - b) Input the (G) signal only; no (R) or B should be visible.
 - c) Input the (B) signal only; no (R) or (G) should be visible.

4.20. Video Noise

Input a cross hatch pattern or full white pattern in primary mode and make a visual check from a distance of 48.3cm (19 inches) for any video noise or other on-screen interference.

4.21. Power Saving Check

1. Input cross hatch pattern in primary mode.
2. Turn OFF H-Sync signal, the power indicator LED have to change the emitting color from green to orange, then turn ON H-Sync signal again, the picture shall be visible.
3. Turn OFF V-Sync signal, the power indicator LED have to change the emitting color from green to orange, then turn ON V-Sync signal again, the picture shall be visible.
4. Turn OFF H/V-Sync signal, the power indicator LED have to change the emitting color from green to orange, then turn ON H/V-Sync signal again, the picture shall be visible.

4.22. DDC 1/2 Data Writing

Writing the DDC 1/2 data in EEROM.

Notes

Section 5.

Troubleshooting

5.1.	No Display at Power-on	5-1
5.2.	No X-ray Operation	5-2
5.3.	No Video Operation.	5-3
5.4.	Poor Vertical Linearity	5-4
5.5.	Poor Horizontal Linearity	5-5
5.6.	Poor Uniformity	5-6
5.7.	Tilted Display Area	5-7
5.8.	Misconvergence	5-8
5.9.	Poor Regulation.	5-9
5.10.	Poor Focus	5-10
5.11.	Poor Geometry Distortion	5-11

5.1. No Display at Power-on

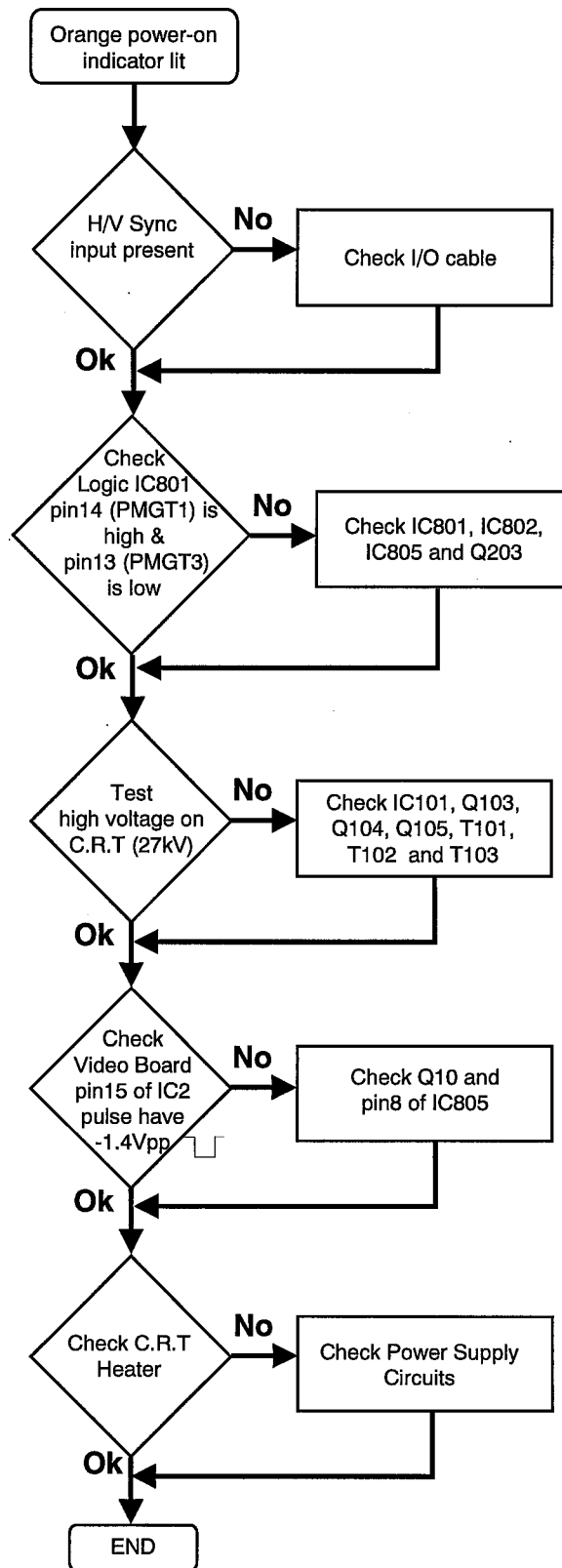

5.2. No X-ray Operation

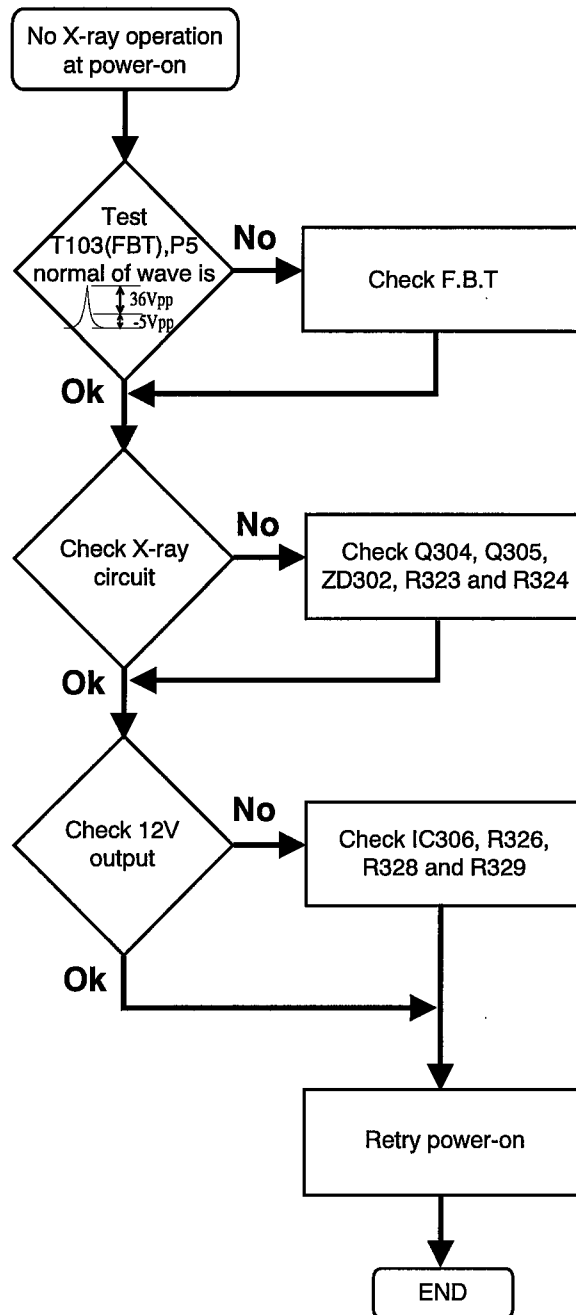

5.3. No Video Operation

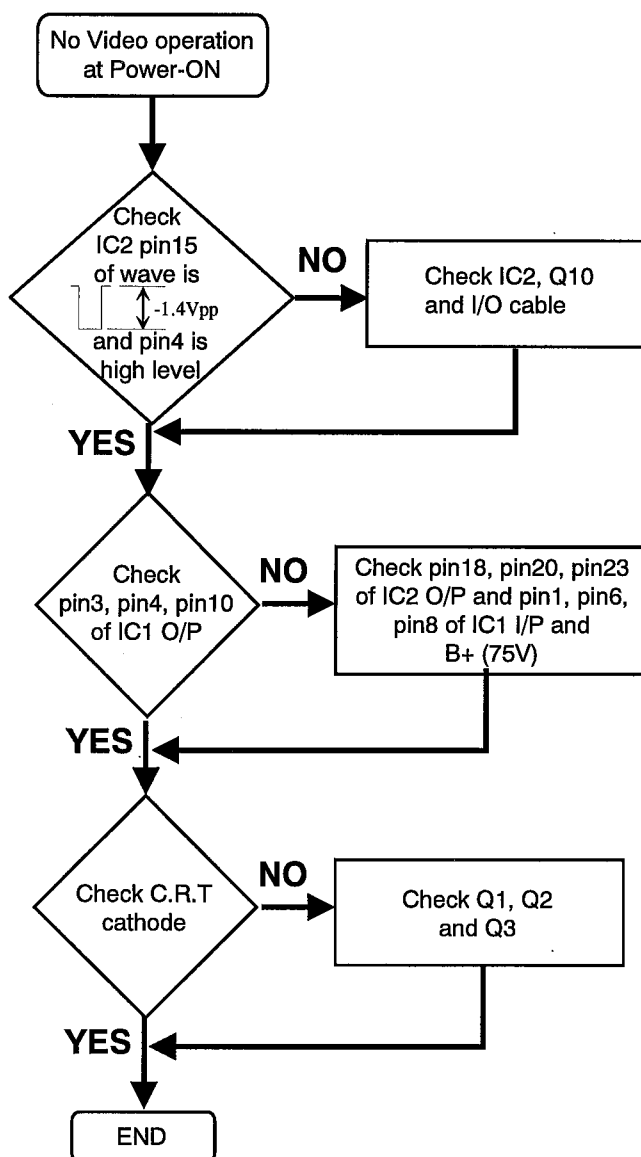

5.4. Poor Vertical Linearity

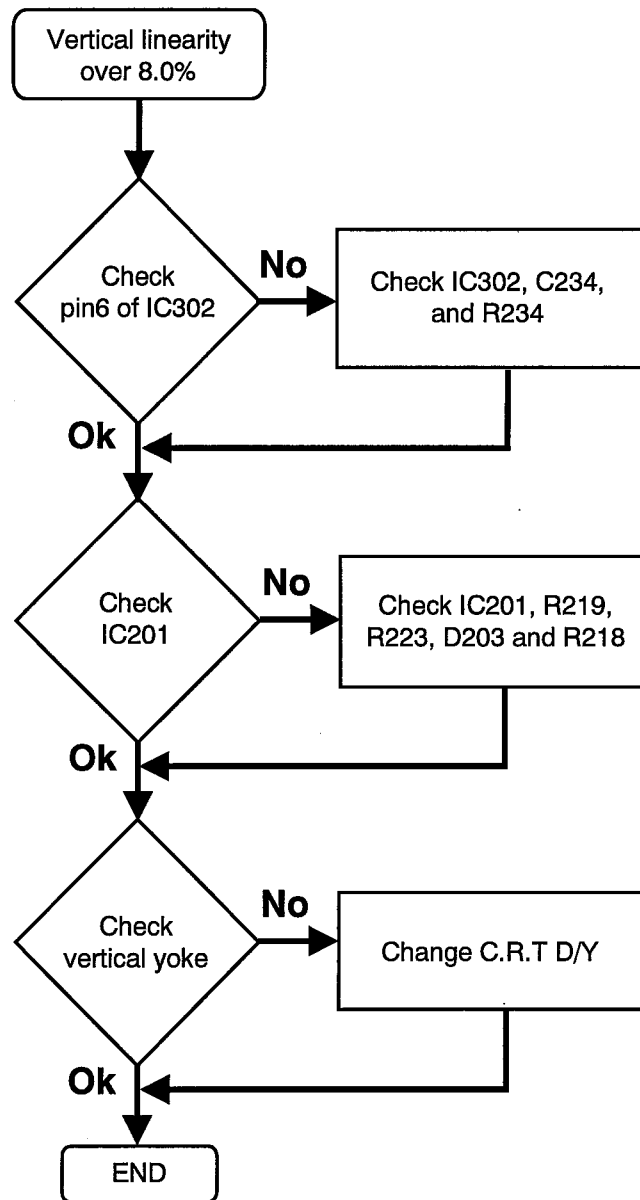

5.5. Poor Horizontal Linearity

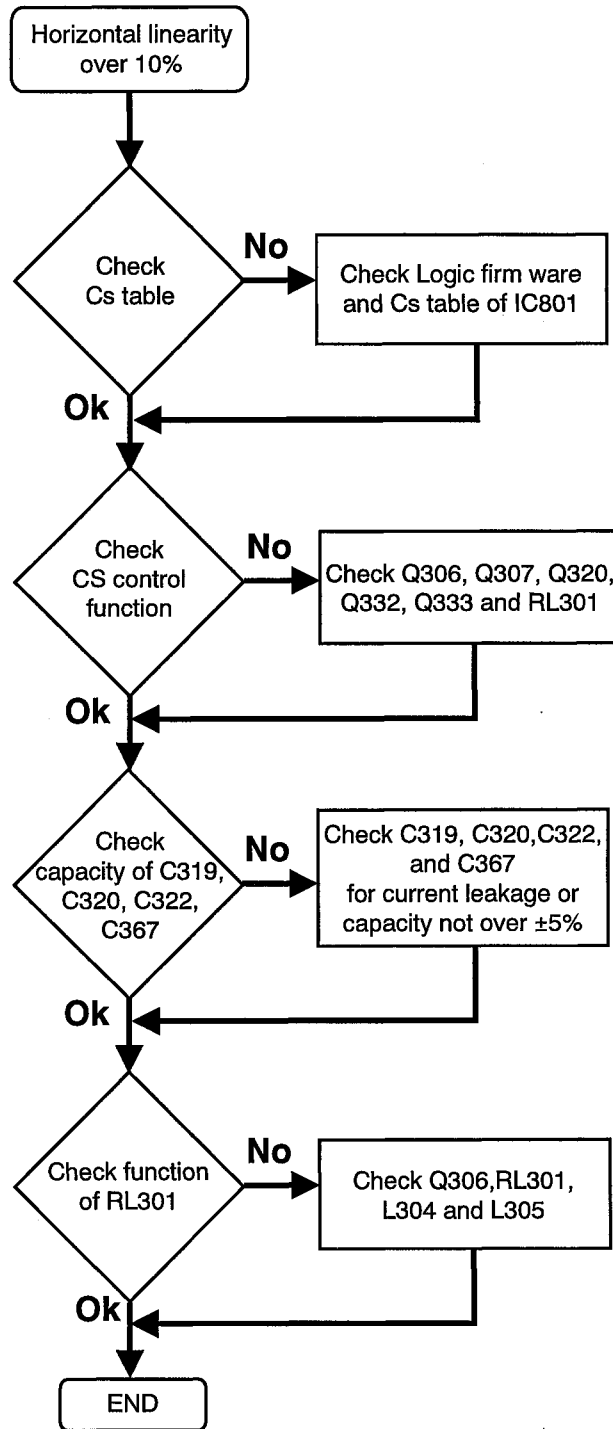

5.6. Poor Uniformity

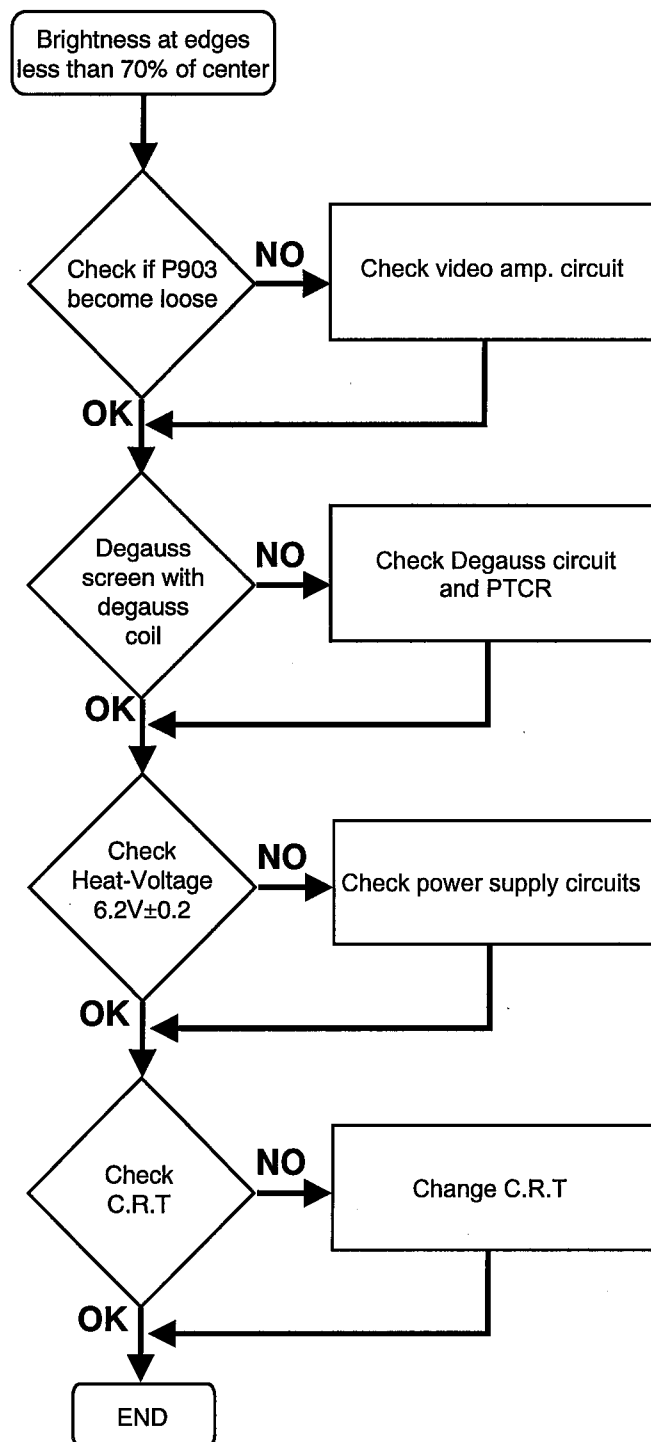

5.7. Tilted Display Area

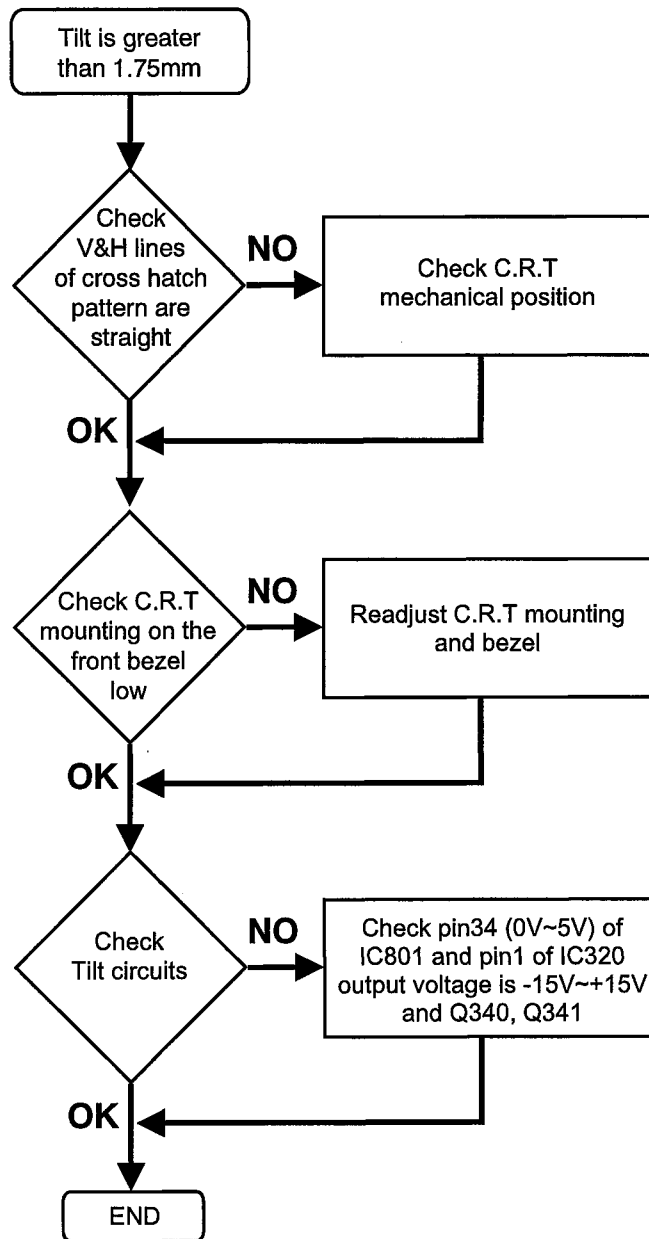

5.8. Misconvergence

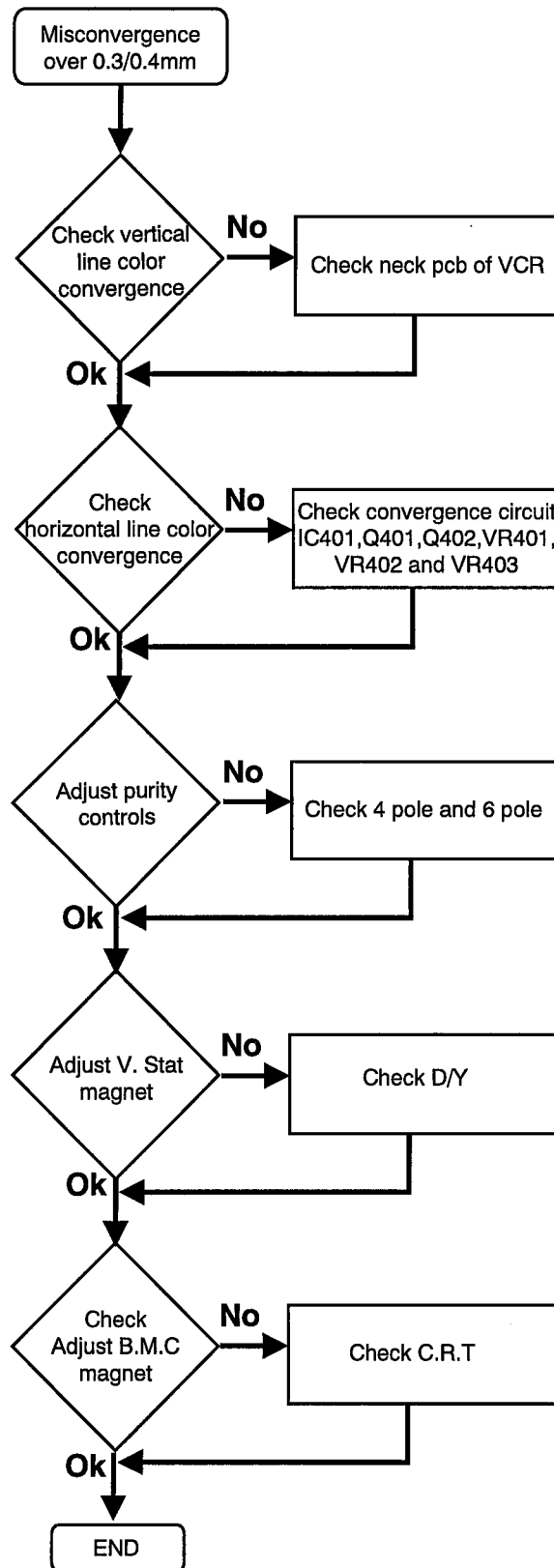

5.9. Poor Regulation

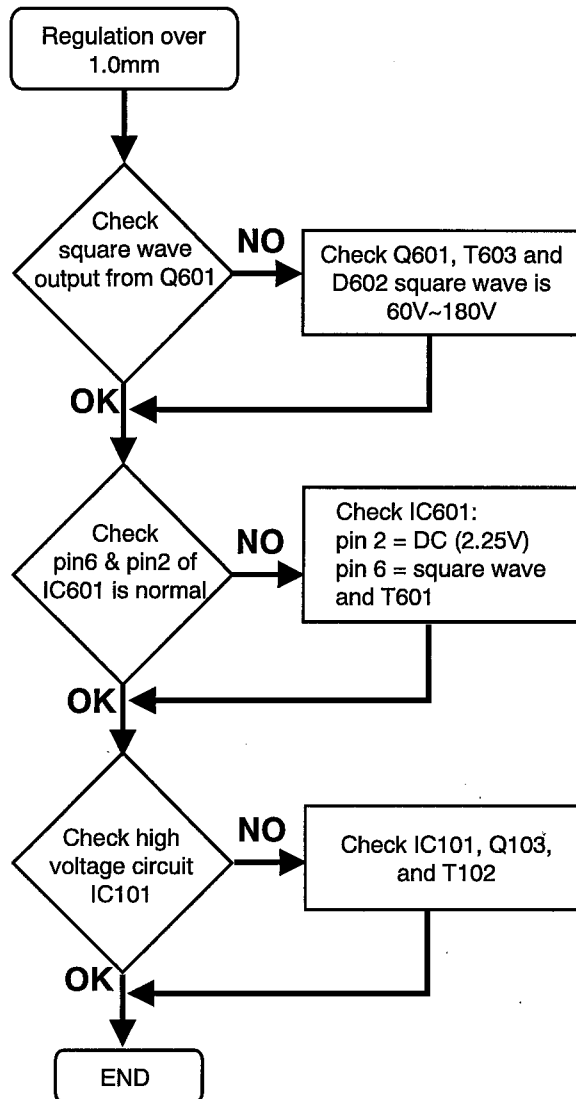

Section 8.

Replacement Parts

8.1.	Exploded View	8-1
8.2.	Key to Exploded View	8-2
8.3.	Replacement Parts List	8-3

8.1. Exploded View

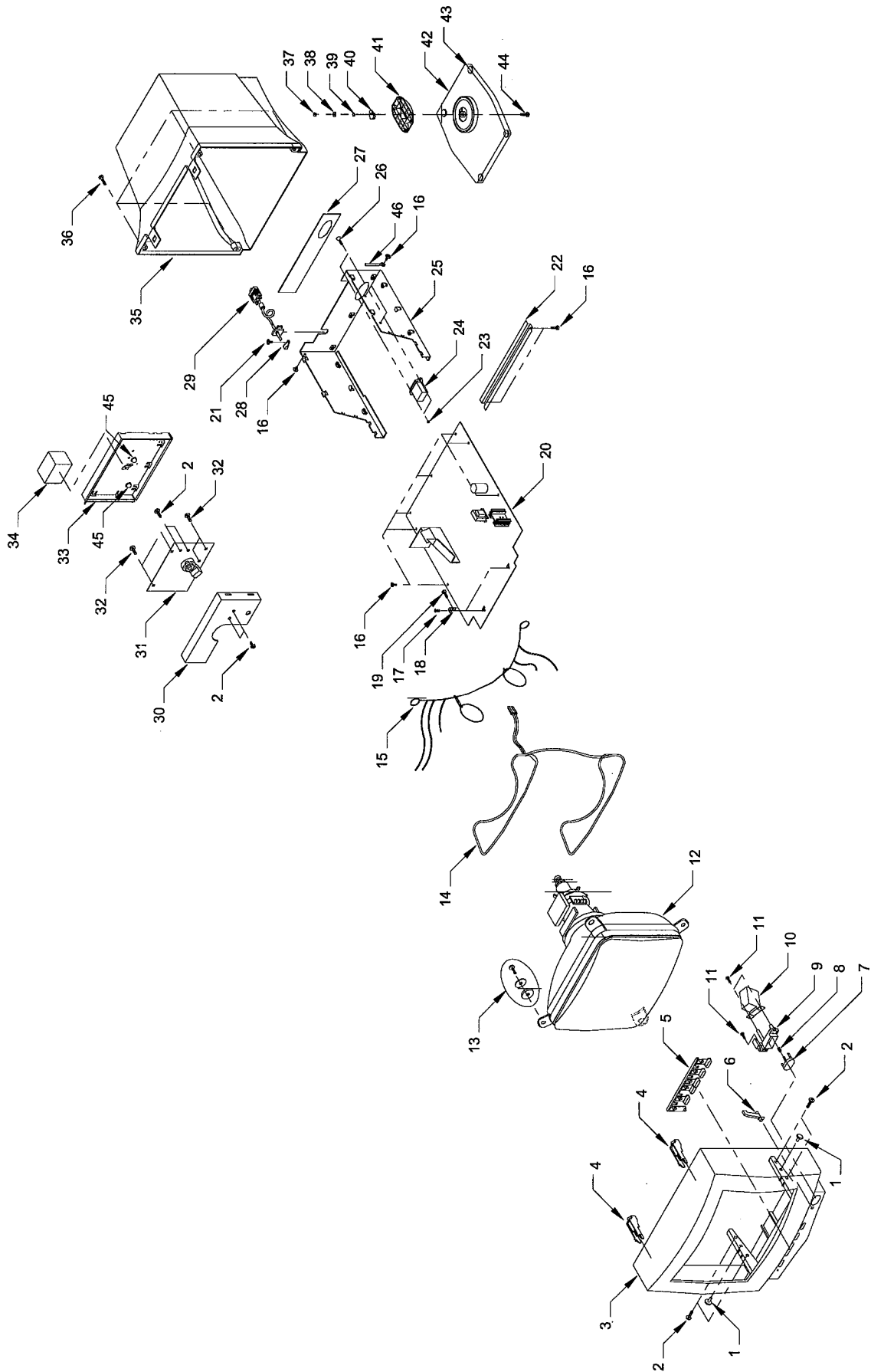

Figure 8-1 Exploded View

8.2. Key to Exploded View

Shaded items indicate components that are critical for safety or are of proprietary design and must be replaced with parts of the exact same specification or ordered directly from the manufacturer.

REF	PART NO	DESCRIPTION
3	T99859111	BEZEL
4	T99859161	BEZEL BRACKET
5	T99859181	PIANO KEY
6	T99859191	LENS
7	T99859171	POWER KNOB
9	T99859151	POWER KNOB HOLDER
13	NOT AVAILABLE	CRT 17SA2K W/ITC (8-738-649-80)
14	T99859601	DEGAUSSING COIL 17"
17	T99859251	SNAP RIVET (for PCB fixing plate)
18	T99859211	PCB FIXING PLATE
20	T99859701	MAIN/NECK FOR ASSY
29	T99859091	I/O CABLE ASSY
35	T99859121	BUCKET
40	T99859201	RETAINER
41	T99859131	TILT BALL
42	T99859141	BASE
43	T99859101	FOOT

8.3. Replacement Parts

Shaded items indicate components that are critical for safety or are of proprietary design and must be replaced with parts of the exact same specification or ordered directly from the manufacturer.

PART NO.	REF DESCRIPTION	DESCRIPTION
NOT AVAILABLE	CRT	CRT 17SA2K W/ITC (8-738-649-80)
T99857511	IC901 - main board	IC UC3842A 8 Pm
T99857771	IC903 - main board	IC TL431 Regulator TO-92 -RT-
T99857831	IC601 - main board	IC UC3843A 8 Pm
T99857941	PH901 - main board	Photo Coupler TRS 4N35 W-10
T99859091		I/O Cable Assy
T99859101		Foot
T99859111		Bezel
T99859121		Bucket
T99859131		Tilt Ball
T99859141		Base
T99859151		Power Knob Holder
T99859161		Bezel Bracket
T99859171		Power Knob
T99859181		Piano Key
T99859191		Lens
T99859201		Retainer
T99859211		PCB Fixing Plate
T99859221	for FBT cover	Heat Sink
T99859231	FBT cover	FBT Cover
T99859241	for IC201 - main board	Heat Sink
T99859251	for PCB fixing plate & PCB	Snap Rivet
T99859261	for LD201	LED Holder
T99859271	for ground wire	Wire Holder
T99859281	for degaussing coil	Wire Mounts
T99859291	R956 - main board	RES - CF 1/2W 1.8 M W SMALL
T99859301	R3A2 for Q303 2SC5331 - main b	RES - CF 1/2W 33R W SMALL
T99859311	R221 - main board	RES - CF 1/2W 330K W SMALL
T99859321	R957, R964 - main board	RES - CF 1/4W 2 M W SMALL
T99859331	R248 - main board	RES - CF 1/4W 4.3R W SMALL
T99859341	Q308 - main board	TRS 2SC4106M W/MOUNTING KIT
T99859351	Q303 - main board	TRS 2SC5331 TO-3P
T99859361	Q105 - main board	TRS 2SC5296 TO-3PML
T99859371	Q103, Q601 - main board	TRS FS10KM-6 TO-220FN
T99859381	Q104, Q302 - main board	TRS MOSFET IRF620 TO-220
T99859391	Q307, Q333 - main board	TRS IRF640 TO-220
T99859401	Q111 - main board	TRS KSP92 TO-92
T99859411	Q1, Q2, Q3 - neck board	TRS BF422 TO-92
T99859421	Q903 - main board	TRS MCR100-6 TO-92 -RT-
T99859431	LD201 - bezel	LED LT6463-23-D51 5> G/Y

Replacement Parts

T99859441	IC805 - main board	IC 74HC86 -14 PIN
T99859451	IC301 - main board	IC LM1291 -28 PIN
T99859461	IC302 - main board	IC LM1295 -24 PIN
T99859471	IC1 - neck board	IC LM2419 -11 PIN
T99859481	IC802 - main board	IC 24LC16 -8 PIN DIP
T99859491	IC306 - main board	IC LM317T W/MOUNTING KIT TO-2
T99859501	IC401 - main board	IC LM324NA -14 PIN
T99859511	IC5 - neck board	IC MS5043-057SP -20 PIN MASK
T99859521	IC320 - main board	IC LMT358N - 8 PIN
T99859531	IC3 - neck board	IC LM393 -8 PIN
T99859541	IC4 - neck board	ICM62393P - 20 PIN
T99859551	IC801 - main board	IC XC68HC705BD5P - 40 PIN
T99859561	IC101 - main board	IC KA7500B - 16 PIN
T99859571	IC902 - main board	IC 7805 REGULATOR - 3 PIN
T99859581	IC201 - main board	IC TDA8172 - 7 PIN
T99859601	Degaussing Coil	Degaussing Coil 17"
T99859611	PTCR - main board	PTCR 9R
T99859621	T903 - main board	Power Transformer
T99859631	T103 - main board	FBT
T99859641	T102 - main board	O/P Transformer
T99859651		Carton
T99859661		Snow Box (R)
T99859671		Snow Box (L)
T99859681		LOGO BADGE
T99859691		Manual
T99859701		Main/Neck FOR Assy
T99859831	Q902 - main board	TRS FS10KM-12 TO -220F
T99859591	AC Power Cord	AC Power Cord Wall UL/CSA Gray

7

KCPCPD996

PRINTED IN USA

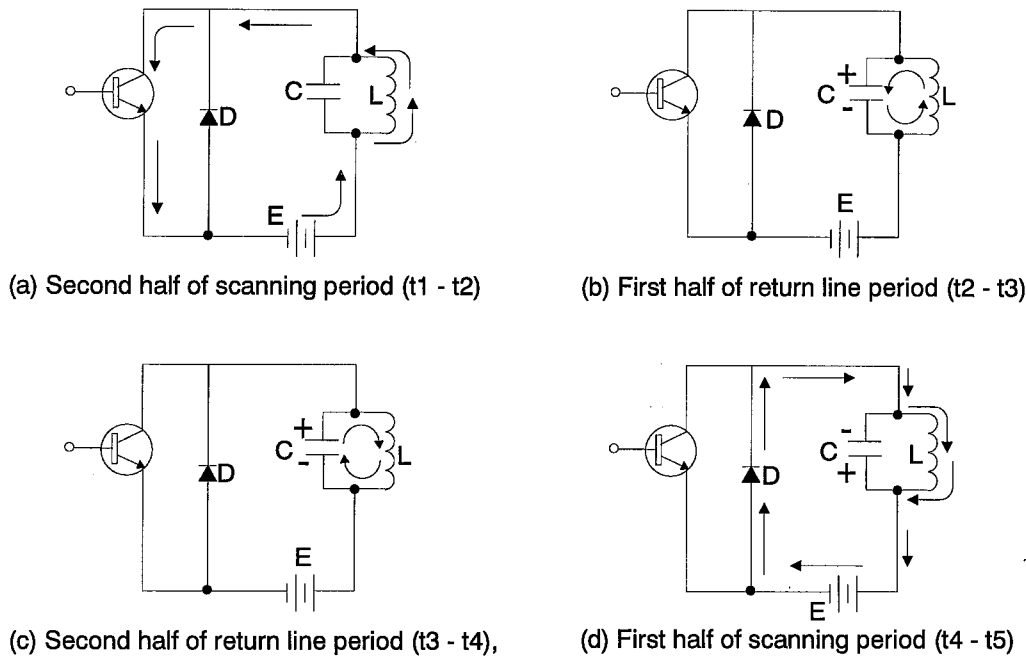

Figure 3-9 Polarity of Transformer Voltage

(c) $t_3 - t_4$ Period

The energy accumulated in C is released to the deflection yoke, the direction of the current flow being shown in Figure 3-9 (c). The current increases as the voltage on C decreases, and at time t_4 , the voltage of C is 0, at which time the current is at maximum, which means the current flowing into the deflection yoke is also maximum. C is then charged and if a damping resistor is not connected, the energy between L and C will be reversed, which is the oscillation frequency set by the oscillator at L and C.

(d) $t_4 - t_5$ Period

At t_4 , the voltage of C is 0. After this it is recharged in the opposite direction and this voltage exceeds the voltage of the power source at time t_4 . At this time the damping diode is ON and the L and C circuits are shorted out and stop oscillating. Because of this the time constant of r and L in the damping diode is large so the current flowing in the deflection yoke does not suddenly become 0. The current shows a linear decrease, and when it becomes 0 at time t_5 the transistor is ON and the operation described above is repeated.

As described above, the current flowing in the deflection yoke during scanning is the sum of the current which has passed through the transistor and the damping diode current. Please refer to Figure 3-8 (e).

4. Horizontal output operation:

The actual output stage differs from the simple model described in a number of ways. Refer to the basic schematic of the major components in Figure 3-10 on the following page.

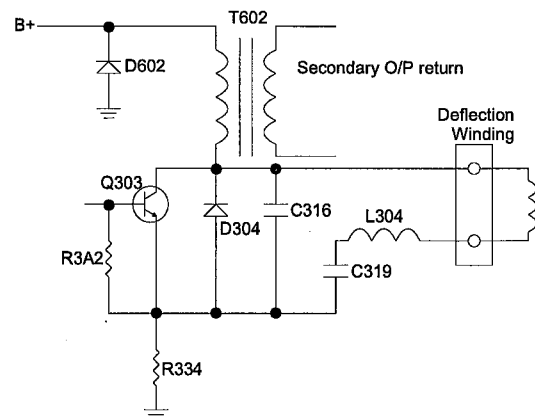

Figure 3-10 Basic Horizontal Deflection Output Circuit

The main inductance L is now divided into the primary winding of the Flyback Transformer (FBT) T602 and the deflection yoke winding. The deflection yoke is coupled through a capacitor C319, which has two function. Primarily it prevents DC unwanted DC currents flowing through the deflection yoke which would otherwise cause an undesirable deflection of the CRT beam.

Secondly, the voltage drop across it due to the AC ramp current flowing causes a parabolic modulation in the slope of the ramp, leading to a progressive curve in the ramp, symmetrical about the zero current value as shown in Figure 3-11. This intentional distortion of the linear ramp is required to compensate for the 'S', or symmetric linearity distortion in the CRT.

In series with C319 and the deflection yoke is another inductor, L304. This is a saturating inductor that is biased with a permanent magnet.

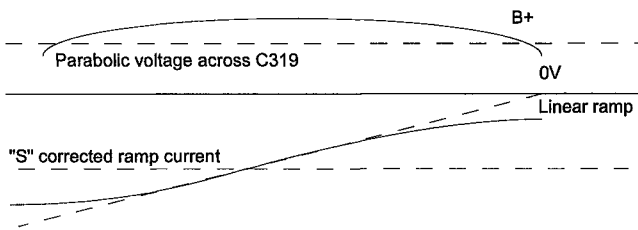

Figure 3-11 Linear Ramp Distortion

Consequently this device has a linearity that is higher for current flow in one direction than in the opposite direction. This function provides compensation for resistive losses that would otherwise cause an undesirable exponential curve to the linear ramp, resulting in asymmetrical linearity errors in the displayed image.

The voltage seen in the output stage require special attention. The B+ supply can vary between 60-180V. The main flyback pulse seen across Q303 and associated components is around 1100Vp. Consequently, appropriate precautionary measures must be taken when servicing the monitor.

In addition to the basic topology as described above, there are a number of other additional devices. Q306, Q307 and Q333 can be independently turned on or off under logic control. These devices switch addition capacitors, C320, C322 and C367 in parallel with C319 to alter the amount of 'S' correction at different horizontal scan frequencies.

D308 and D309 acts as a constant current source that can be under SW301 and SW302 control. This current source drives an adjustable constant current into L304. This current flows into the deflection yoke and adds a variable DC offset to allow image raster centering to be achieved.

The B+ provides current for the deflection coil (D/Y). Therefore, changes in deflection current can be controlled by modifying B+ voltage. As a result, horizontal width can be modified. In order to obtain the side horizontal width for different frequencies, a DC to DC feedback circuit is added. The synchronization signal comes from deflection output, from pin 12 of T602 to base of Q603 which drives Q604 to trigger pin 4 of IC601. Feedback signal come from secondary on T601, via D604, R611 and R612 to become a DC voltage on pin 2 of IC601, another feedback signal passes through emitter of Q303, via R606 on pin 3 of IC601. These signals determine duty cycle of output signal of IC601 which is coupled to T603 to drive Q601, to control B+, making it possible to have correct deflection current and horizontal width on different frequencies. Similarly,

output pin 36 of IC801 drive through R368, C348 and R610 to control duty cycle of IC601 output to achieve horizontal width adjustment.

During mode change, the B+ supply can be instantly turned off by pulling up the error amplifier input on pin 1 of IC601. These can be achieved by Q602, Q606 and Q605 which is driven from the logic circuit pin 9 of IC801 (MUTE). Whilst Q602, Q606 and Q605 can switch off the B+ supply almost instantly, the time taken for the supply to restart is programmed by the value of logic circuit.

In addition, the B+ (177V) supply is configured so as to maintain a constant anode voltage. The anode voltage is derived from the flyback transformer T103. As the flyback voltage across the primary is already a high voltage pulse of around 800Vp, it requires only a modest turns ratio to step this pulse up to around 27kV, the working voltage of the CRT. Refer to the basic schematic of the major components in figure 3-12.

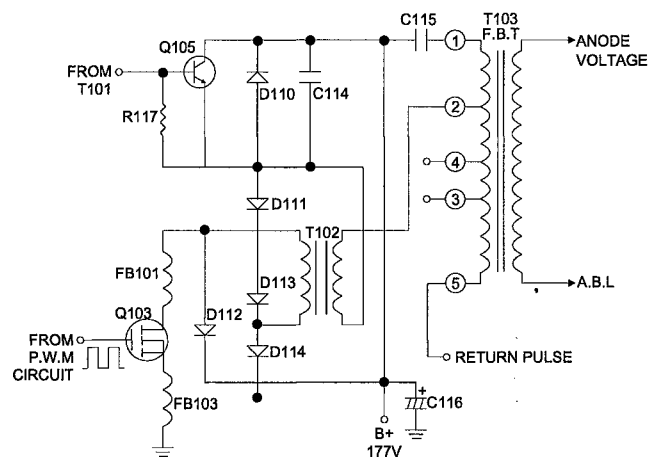

Figure 3-12 Basic High Voltage Output Circuit

The flyback pulse at the primary of T103 is proportional to the both frequency and the supply rail B+. In order to maintain the anode voltage at a constant 27kV a regulation system is required. This is achieved using a PMW regulation stage formed by a IC101 driving a Q103. The causes a regulating current on primary T102, the voltage changes in secondary T102 result in a constant high voltage, synchronized by the horizontal oscillator. The IC101 has an error amplifier that generates an error signal from the feedback network formed by the high voltage bleed resistor and capacitor (it is internal to T103). Resistors VR101, R103 and R104 set the DC feedback ratio, and by adjustment of VR101, this ratio can be adjusted at setup to set the high voltage at it's nominal value of 27kV. The AC frequency response of the serve loop is set by C104 and R114 for

optimum stability and relegation characteristics.

The output of the error amplifier which can be observed on pin 1 of IC101 is internally compared with a DC voltage. This DC is produced across.

The average beam current through the CRT also flows through the secondary high voltage winding of T103 connected to pin 8 of T103, C132 and R138 smooths the pulse of current flowing in the secondary winding and the average DC current is supplies through resistor R137 and VR106. When the average secondary current flowing exceed 460mA, this voltage begins to drop below this threshold. Thus a signal is generated which can be fed to video amplifier for automatic beam current limiting (ABL).

3.2.8. X-RAY Protection Circuit

The feedback pulse voltage from T103 F.B.T is regulated through D302 to obtain a DC voltage and the appropriate set voltage is distributed by R323 and R324. When the feedback pulse voltage exceeds the set voltage, a DC voltage develops in the cathode of ZD302 which turns on Q304 and Q305. As a result, the pin 1 of IC306 (adj-pin) to 0V, so IC306 is turned off, putting the 12V is not output. This is the phenomenon of high voltage protection.

3.2.9. The Focus Circuit

The output waveform come from pin 16 of IC302 through C122 and R123 to the amplifier Q106, via T104 with horizontal waveform to modulation. After, the wave coupling of the T103 which make the focus performance on the C.R.T. This is waveform shown in figure 3-13.

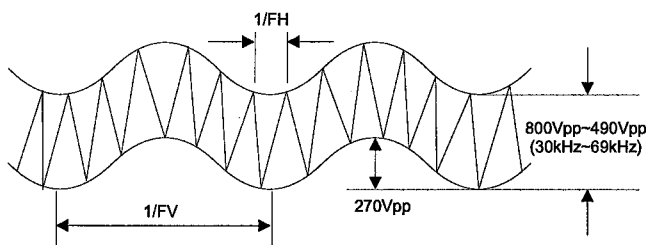

Figure 3-13 Focus Correction Wave

3.2.10. Horizontal linearity and CS Switching

Switching CS is necessary to ensure the lines are in accordance with the specifications in multi-sync monitors.

- For frequencies 58~69kHz, Q307 and Q333 are OFF and RL301 is ON, so CS is only C319, but L304 and L305 in parallel.

- For frequencies 45~58kHz, Q307 is OFF, RL301 and Q333 are ON, so CS are C319 and C367 in parallel, but L304 and L305 are in parallel.
- For frequencies 39~45kHz, RL301, Q307 and Q333 are OFF, so CS are C319 and C320 in parallel, but linear coil is only L304.
- For frequencies 33~39kHz, RL301 and Q307 are OFF, Q333 is ON, so CS are C319, C320 and C367 in parallel, but linear coil is only L304.
- For frequencies 29~33kHz, RL301 is OFF, Q307 and Q333 are ON, so CS are C319, C320 C322 and C367 in parallel, but linear coil is only L304.

Truth Table of Frequency Discriminator					
FEQ CS	29~33 kHz	33~39 kHz	39~45 kHz	45~58 kHz	58~69 kHz
CS1	L	L	L	H	H
CS2	L	L	H	L	H
CS3	L	H	H	H	H
CF	L	L	L	L	H

Truth Table of Power Saving Detector						
Mode	H-sync	V-sync	PMG1	PMG3	Mute	Blanking
ON	Pulse	Pulse	1	0	0	0
Standby	No Pulse	Pulse	1	1	1	1
Suspend	Pulse	No Pulse	0	1	1	1
OFF	No Pulse	No Pulse	0	1	1	1

3.2.11. The Misconvergence Circuit

The sawtooth wave come from IC201 through R401 and C401 to the pin 2 and pin 6 of IC401 amplifier. The sawtooth wave is output from pin 7, pin 14 and pin 8 of IC401 which amplify of two group amplifier defines, by VR401, VR402 and VR403 for adjustment. Then, the top, bottom and center portions of the display will be expanded or compressed, resulting in poor convergence on the horizontal lines. In order to solve this problem, correction of the horizontal line convergence of the sawtooth wave can be carried out before the drive balanced. Via Q401 and Q402 a manner push pull current amplifier which provide to achieve horizontal line convergence correction.

3.3. Video Amplifier

The RGB video and sync signals are supplied through a video cable directly to the Video Board at connector P1. The RGB signals are terminated in 75 ohms by R39 and R42, R38 and R41.

The RGB signals then enter an IC2 LM1282 video pre-amplifier, providing synchronous black level clamping, variable picture contrast (gain) and RGB gain balance for alignment. Separate gain control voltages for the three pre-amplifier channels are provided via R34, R33 and R32 from the IC4 M62393 DAC which is loaded by the microcontroller via the I2C bus. These inputs enable the individual gains of each channel to be varied to allow channel gain balance. In addition, a common signal is applied on pin 13 of IC2 to adjust all three channels by the same amount, to allow for overall gain or contrast control.

A synchronous clamping signal is derived from the horizontal sync pulse by Q10. This takes the trailing edge of the horizontal sync pulse, differentiates it through C39 and R53, which is applied pin 15 of IC2. The timing is shown in Figure 3-14.

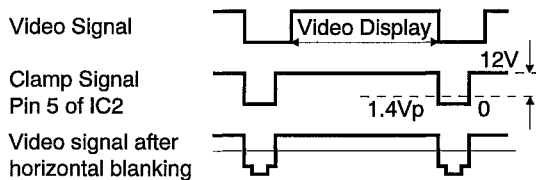

NOTE:

- A. Clamp signal is generated from horizontal sync pulse time.
- B. When the Clamp signal is less than 1.4Vp-p, the IC's internal clamp loop will operate; when greater than 1.4Vp-p, it will not operate.

Figure 3-14 Timing of Pin 15 Clamp Signal

The outputs of the video pre-amplifier are fed to IC1, a hybrid power amplifier IC type LM2419, through resistors R21, R23 and R25. In addition, on screen display video information generated by IC2 can be injected via R28, R29 and R27 through pin 1, pin 2, and pin 3 of IC2.

IC1 amplifies the video signals to around 40Vp-p. The outputs are AC coupled to the CRT cathodes via C1, C4 and C3. In order to bias the DC level of the cathodes correctly, the AC coupled signal is DC restored by clamping to a DC voltage which can be varied under microprocessor control. Considering Red channel output on IC1 as an example, the signal is clamped by D2 to the voltage set by the transistor amplifiers formed by Q1, which amplify the adjustable voltage at the output of the DAC. A similar stage can be seen for the green and blue channel outputs.

When the RC video signal amplification circuit is added for amplification, this waveform will change as shown in Figure 3-15 (a). Without the DC component, as shown in Figure 3-15 (b), the DC level of darker and brighter displays will be different, so when this kind of signal without a DC component is sent to the CRT, it will cause the contrast of the image to change as the signal changes. Therefore Q1, Q2, Q3, D2, D22 and D12 serve as a DC clamp and the CRT's cathodes DC voltage can be adjusted by the pin 13, pin 14, pin 15 of IC4 M62393 DAC.

IC5 is an On Screen Display processor. This is a simple video generation IC5 that has its own oscillator circuit. The oscillator circuit by using an internal Phase Locked Loop (PLL) the IC5 can sync to the incoming vertical and horizontal oscillator frequencies and produce the OSD video signals once initialized and loaded by the commands and data received on the I2C bus. When the OSD display is activated, the blanking

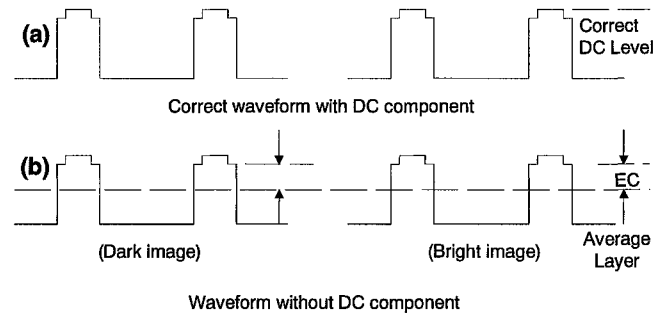

Figure 3-15 The Post Output Amplifier Circuit

output of the IC5 also sends a signal to the blanking input of IC2 (pin 4) to provide an optional black background for the OSD display.

The RGB signals are amplified to drive the CRT by an IC1 LM2419 hybrid amplifier and capacitively coupled to the cathodes.

Brightness control is achieved by varying the bias of G1 of the CRT via a transistor stage formed by Q111 which is also driven by an output of the pin 12 of IC4. Vertical blanking signals is coupled into this amplifier Q204, Q205 and Q202 to prevent visible retrace lines.

3.4. Microprocessor And Sync Processing

The microprocessor is a MC68HC705BD3P type. It is particularly suitable as multisync computer monitor controller. This 8-bit microcontroller unit (MCU) contains an onchip oscillator, CPU, RAM, ROM, M-Bus serial interface system (IIC), parallel I/O, Pulse Width Modulator, Multi-Function Timer and sync Signal Processor. It has a 7.75k bytes of ROM and 256 bytes of RAM on internal which contains a basic communication 'boot' routine and various other simple routines. It is also used to store the OSD icon bit map. The main firmware routines and variable data stored in the 16k external EEROM, IC802.

When the micro is instructed via the IC2 bus, the internal ROM boot routine will load up the EEROM with program data from the IC2 bus. Thus it can be made to load its own firmware. From then on it will run jointly out of EEROM and internal ROM. Another important routine within the internal ROM is the routine which allows data writes to be made to the EEROM. This must be resident in the micro as it cannot run from the EEROM whilst writing data. These control the addressing and I/O port selection from the micro CPU in the IC801 (MC68HC705BD3P).

Also specialized ports Pin 16, Pin 17 and Pin 18 of IC801 form the M-Bus interface which is used internally to set the DAC valuse and the OSD IC and CS table control IC (IC801). Other way, specialized ports pin 11 and pin 12 of IC801 from the M-bus interface which is used internally to set the data to external EEROM IC802. In addition, the I/O ports from pin

Safety Standards and Approvals

- This monitor complies with DHHS Rules 21 CFR Subchapter J Applicable at date of manufacture.
- Certified to comply with the limits for a Class B computing denice pursuant to part 15 of FCC rules
- Please refer to instructions included FCC motice in the user's manual id this equipment is suspected of causing interference to radio reception.

Important Safety Notice

This equipment contains special components which are important for safety. These critical parts should only be replaced with the parts specified by the manufacturer in order to prevent X-radiation, shock, fire or other hazards. Do not modify the original design.

Before You Start

General Safety Precautions

1. Use an isolation transformer in the power line and AC supply to troubleshoot.
2. When servicing, observe the original lead dress, especially in the high voltage circuits. If a short circuit is found, replace all parts which have been overheated or damaged.
3. Before turning the display on, measure the resistance between B+ line and chassis ground. Connect the negative side of an ohmmeter to the B+ lines and the positive side to chassis ground. Each line should have more resistance than the following specifications:

B+ Line	Minimum Resistance
+177V	127.35K Ω
+75V	50.58K Ω
+15V	22.23K Ω
-12V	13.18K Ω
+6.3V	3.45 Ω
+5V	1.35K Ω

4. Potentials, as high as 26kV are present when this display is in operation. Operation of the display without the rear cover involves the danger of a shock hazard from the display power supply. Servicing should not be attempted by anyone who is not thoroughly familiar with the precautions necessary when working on high voltage equipment. Always discharge the anode of the picture tube to the display chassis before handling the tube.
5. After servicing, be sure to check the items listed in the Safety Checkout, below before returning the serviced unit to the customer.

Safety Checkout

The following checks must be made after correcting the original service problem and before the unit is returned to the customer.

1. Check the area of your repair for unsoldered or poorly soldered connections. Check the entire board surface for solder splashes and bridges.
2. Check the inter board wiring to ensure that no wires are pinched or coated with high-wattage resistors.
3. Check that all control knobs, shields, covers, ground straps and mounting hardware have been replaced. Make absolutely sure you have replaced all the insulators.
4. Look for any unauthorized replacement parts, particularly transistors, that may have been installed during a previous repair. Point them out to the customer and recommend their replacement.
5. Look for parts which, though functioning, show obvious signs of deterioration. Point them out to the customer and recommend their replacement.
6. Check the line cord for cracks and abrasion. Recommend the replacement of any such line cord to the customer.
7. After making any repair, check the B+ and HV to see whether they are at the values specified. Make sure your instruments are accurate; if your HV meter always shows a low HV, check the meter to ensure it is not malfunctioning.
8. Carry out the leakage current checks as detailed below overleaf.

Leakage Current Cold Check

1. Unplug the AC cord and connect a jumper between the two prongs on the plug.
2. Turn on the display power switch.
3. Use an ohmmeter to measure the resistance value between the jumpered AC plug and each exposed metallic cabinet part on the display, such as screwheads, terminals control shafts, etc. When an exposed metallic part has a return path to the chassis, the reading should be between 240k and 5.2M. When exposed metal does not have a return path to the chassis, the reading must be.

Leakage Current Hot Check

1. Plug the AC cord into the AC outlet. Do not use an isolation transformer for this check.
2. Connect a 1.5k, 10 watt resistor in parallel with a 0.15F capacitor between each exposed metallic part on the set and a good earth ground (see How to Find a Good Earth, below) as shown in the diagram below.

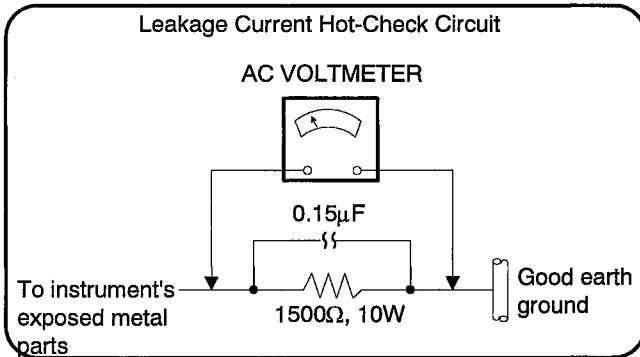

Example of Leakage Current Hot-Check Circuit

3. Use an AC voltmeter with 1000 ohms/volt or more sensitivity to measure the potential across the resistor.
4. Check each exposed metallic part, and measure the voltage at each point.
5. Reverse the polarity of the AC plug in the AC outlet and repeat the above measurements.
6. The potential at any point should not exceed 0.75 volt RMS. A leakage current tester (Simpson Model 229, RCA WT-540A or equivalent) may be used to make the hot checks.

Leakage current must not exceed 0.5 milliamp. If a measurement is outside of the specified limit, there is a possibility of a shock hazard and the monitor should be repaired and re-checked before it is returned to the customer.

How to Find A Good Earth

A cold water pipe is a guaranteed earth ground; the cover plate retaining screw on most AC outlet boxes is also at earth ground. If the retaining screw is to be used as your earth ground, verify that it is at ground by measuring the resistance between it and a cold water pipe with an ohmmeter. The reading should be zero (0) ohms. If a cold water pipe is not accessible, connect a 60-100 watt trouble light (not a neon lamp) between the hot side of an AC power receptacle and the retaining screw. Try both slots, if necessary, to locate the hot side of the line. The lamp should light at normal brilliance if the screw is at ground potential.

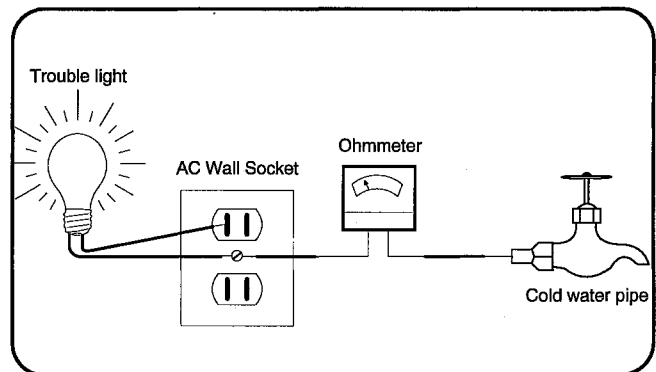

How to Check for Earth Ground

19 to pin 23 of IC801 from the M-bus interface which is used internally to set the front panel control.

There are 16 PWM channel. Channel 0 to channel 7 are dedicated PWM channels while channel 8 to channel 15 are shared with ports C under the control of the corresponding configuration register. Thus it can be made to control H-PHASE, PARALLELOGRM, PIN-BALANCE, TRAPEZOID, PINCUSHION, TILT, V-SIZE, H-SIZE and V-POSITION on the pin 1, pin 26, pin 27, pin 28, pin 29, pin 34, pin 35, pin 36, pin 37 and pin 38 of IC801.

The micro also drives the sync selection circuits. IC801 is used to set the polarity of the incoming sync signals and allows the micro to sample the vertical and horizontal syncs and to select the correct polarity on the outputs H-SYNC and V-SYNC appropriately. In addition, whilst sampling the polarity, the micro can measure the frequency of both syncs. By suitable selection of H-SYNC and V-SYNC control lines, it does this when ever a mode change occurs. A mode change is detected by either a change in vertical frequency, which is monitored by firmware, or by a sudden change in horizontal frequency.

When power is disturbed to the unit, the power reset line goes low. This also causes an input to the micro via the MODEC line. On detecting this interrupt, the micro first checks inputs Pin 4 of IC801. If these are also low, then it knows the MODEC interrupt was caused by an impending power failure. In this case the micro saves the current RAM data in EEROM and prepares for power off. The RESET line is delayed for 7ms by R801, ZD801, R803 and C801 to allow time for the data to be saved. The REST line then holds off the micro and the EEROM until power is good once more.

Notes

5.10. Poor Focus

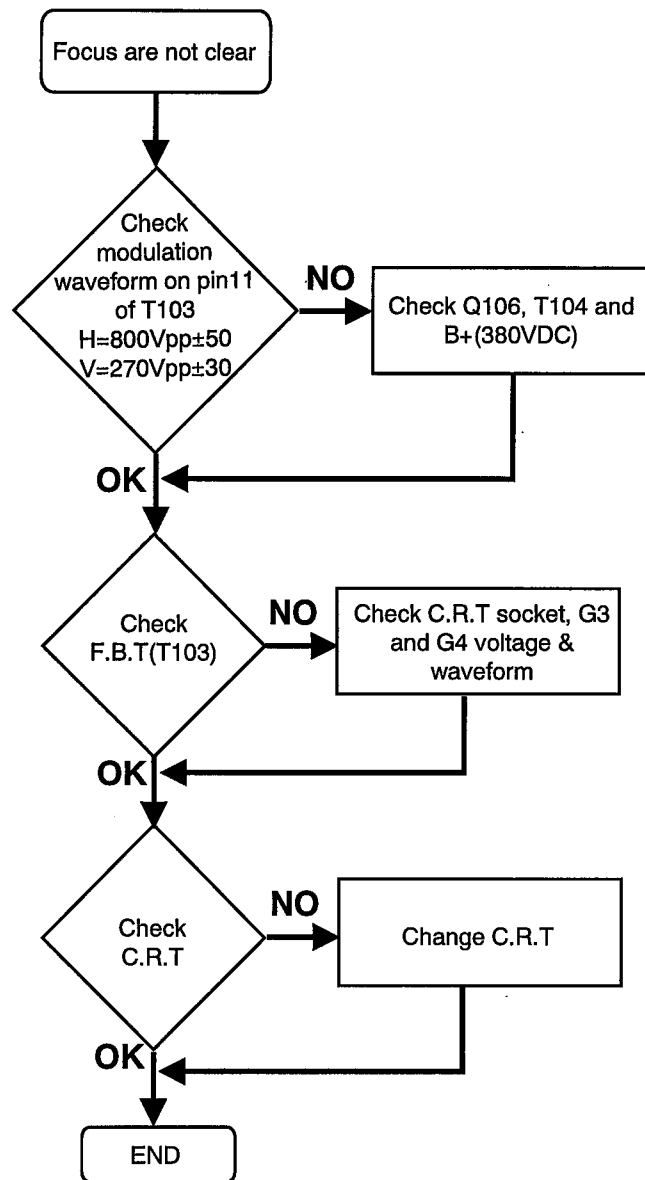

5.11. Poor Geometry Distortion

