

PROCESS CPD74

Switching Diode

Monolithic Isolated Quad Switching Diode Chip



PROCESS DETAILS

Die Size	25 x 25 MILS
Die Thickness	6.0 MILS
Anode 1, 2, 3, 4 Bonding Pad Area	3.5 x 4.0 MILS
Cathode 1, 2, 3, 4 Bonding Pad Area	3.5 x 4.0 MILS
Top Side Metalization	Al - 12,000Å
Back Side Metalization	Au - 5,000Å

GEOMETRY

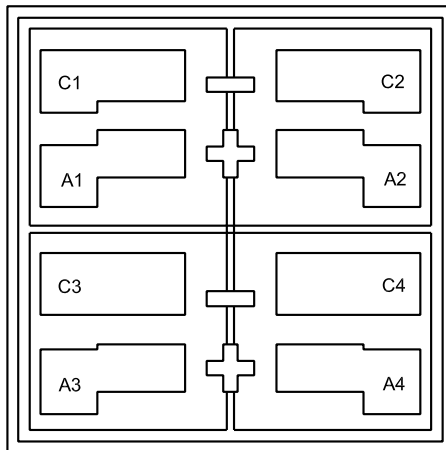

R0

GROSS DIE PER 3 INCH WAFER

10,000

PRINCIPAL DEVICE TYPES

CMEDA-6i

R2 (22-March 2010)

PROCESS CPD74

Typical Electrical Characteristics

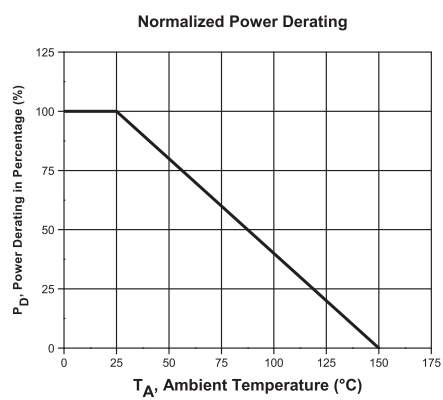
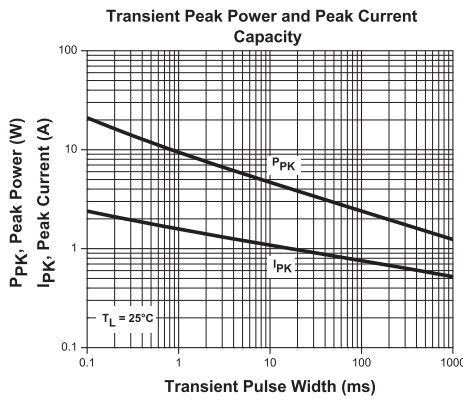
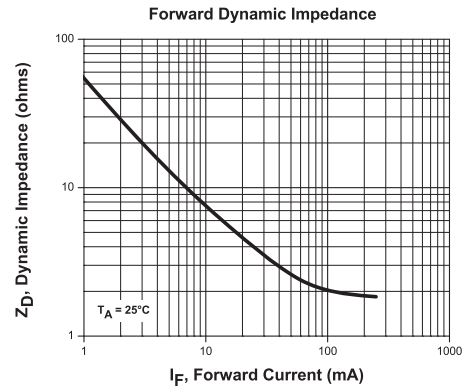
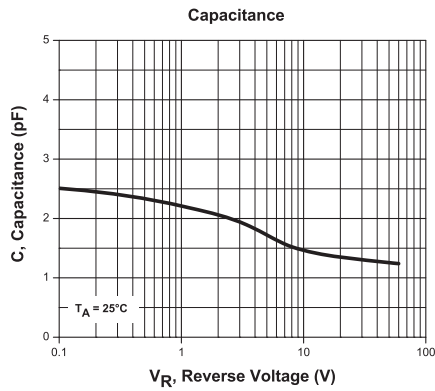
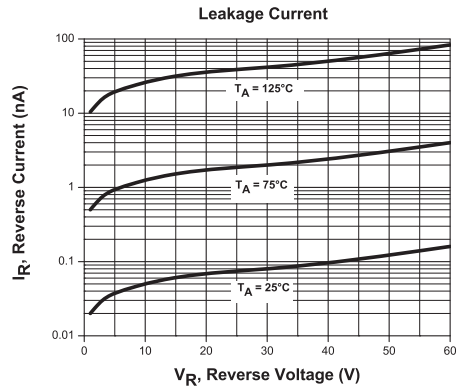
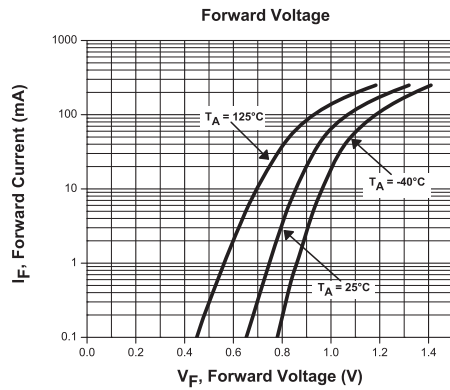

R2 (22-March 2010)