

PROCESS CPD79
Schottky Rectifier
2 Amp Schottky Rectifier Chip



PROCESS DETAILS

Die Size	49 x 49 MILS
Die Thickness	9.8 MILS
Anode Bonding Pad Area	39 x 39 MILS
Top Side Metalization	Al/Ni/Au - 30,000Å/3,000Å/1,500Å
Back Side Metalization	Ti/Ni/Au - 1,600Å/5,500Å/1,600Å

GEOMETRY

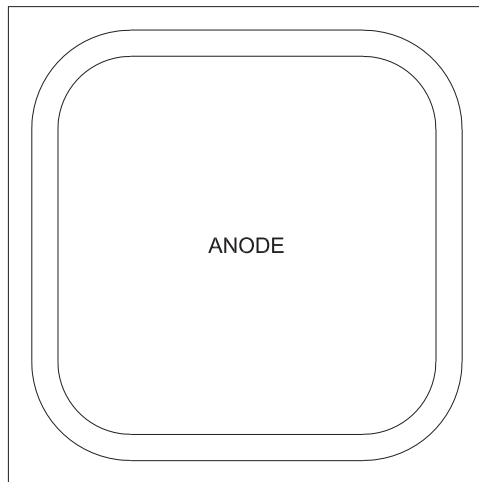

GROSS DIE PER 4 INCH WAFER

4,608

PRINCIPAL DEVICE TYPE

CTLSH2-40M832

BACKSIDE CATHODE R0

R0 (19-July 2010)

PROCESS CPD79

Typical Electrical Characteristics

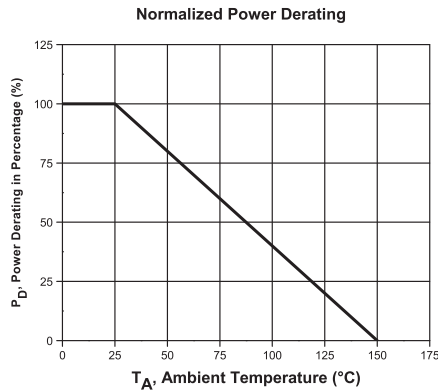
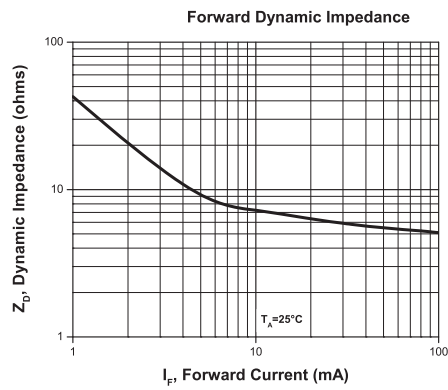
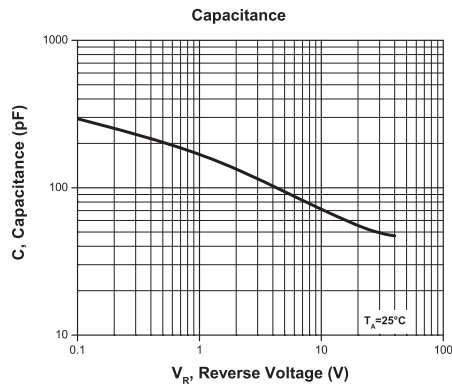
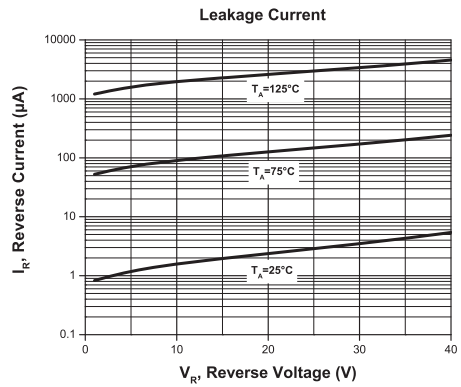
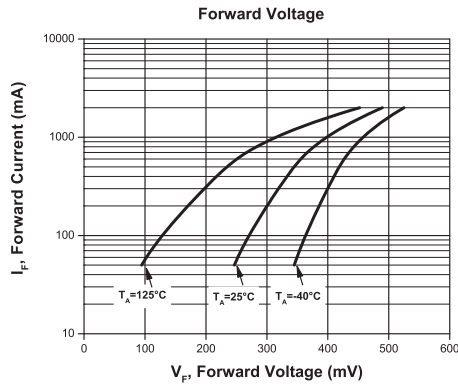

R0 (19-July 2010)