

SMD ESD Protection Diode

CPDT-12V (RoHS Device)

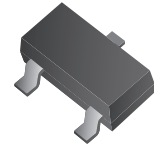

Features

- Common anode ESD protection.
- IEC61000-4-2 8kV(Contact), 15kV(air).
- Surface mount package.
- High component density.

Mechanical data

- Case: SOT-23 Standard package, molded plastic.
- Terminals: Gold plated, solderable per MIL-STD-750D, method 2026.
- Marking code:E12
- Mounting position: Any.
- Weight: 0.0078 gram(approx.).

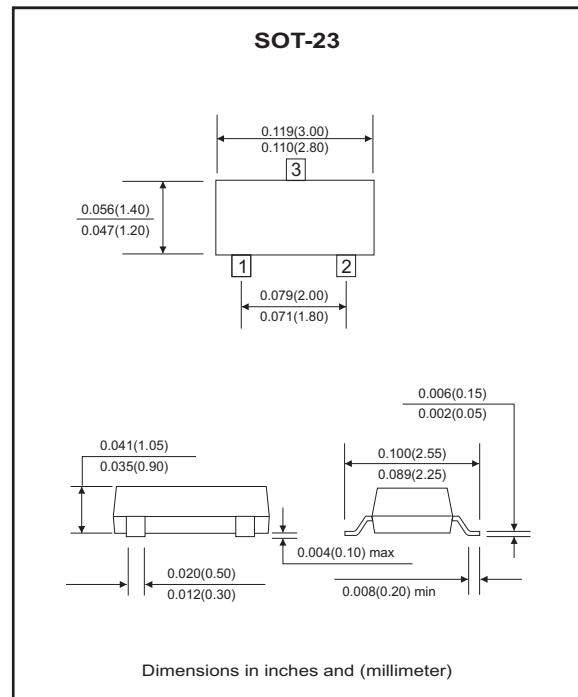
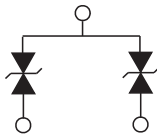

Maximum Rating and Electrical Characteristics (at TA=25°C unless otherwise noted)

Parameter	Conditions	Symbol	Min	Typ	Max	Unit
Diode breakdown voltage	$I_R = 1\text{ mA}$	V_{BD}	13	17		V
Leakage current	$V_R = 12\text{ V}$	I_L		0.1	2.0	μA
Junction capacitance	$V_R = 0\text{ V}, f = 1\text{ MHz}$	C_T		12		pF
ESD capability	IEC 61000-4-2(air) IEC 61000-4-2(contact)	ESD			16 8	kV
Clamping voltage	$I_{PP} = 1\text{ A}, T_P = 8/20\mu\text{s}$	V_C			25	V
Peak pulse power	$T_P = 8/20\mu\text{s}$	P_{PP}			25	W
Operation temperature		T_j			125	°C
Storage temperature		T_{STG}	-55		150	°C

SMD ESD Protection Diode

RATING AND CHARACTERISTIC CURVES (CPDT-12V)

Fig. 1 - 8/20us Peak pulse current wave form acc. IEC 61000-4-5

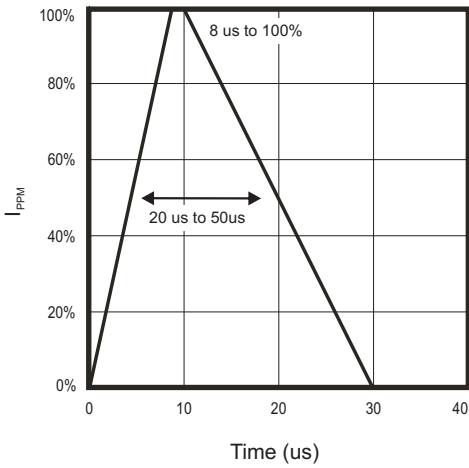

Fig. 2 - Reverse characteristics

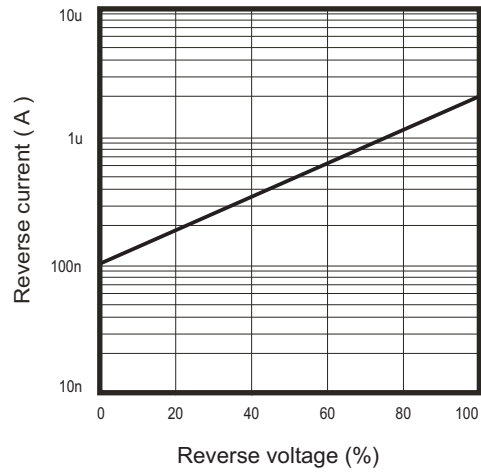

Fig. 3 - Capacitance between terminals characteristics

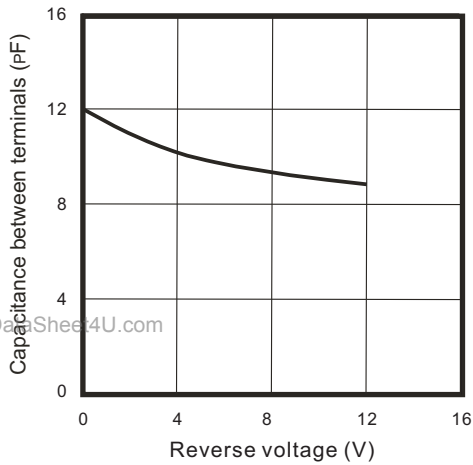
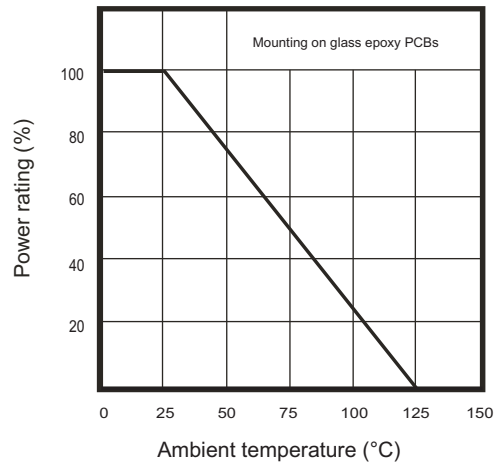

Fig. 4 - Power rating derating curve



www.DataSheet4U.com

SMD ESD Protection Diode

Reel Taping Specification

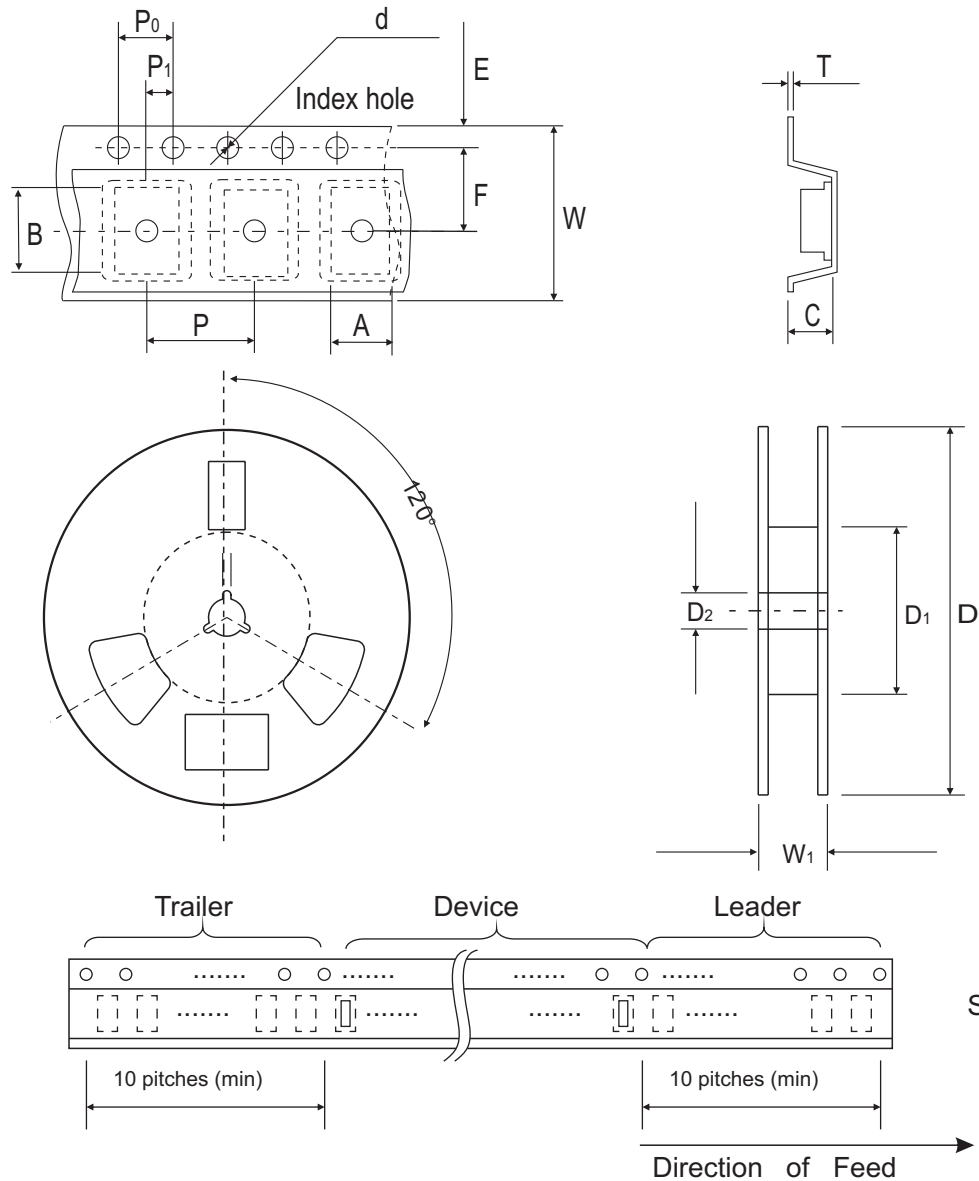

www.DataSheet4U.com

SOT-23	SYMBOL	A	B	C	d	D	D ₁	D ₂
	(mm)	3.10 ± 0.10	2.85 ± 0.10	1.40 ± 0.10	1.55 ± 0.10	178 ± 1	50.0 MIN.	13.0 ± 0.20
	(inch)	0.122 ± 0.004	0.112 ± 0.004	0.055 ± 0.004	0.061 ± 0.004	7.008 ± 0.04	1.969 MIN.	0.512 ± 0.008

SOT-23	SYMBOL	E	F	P	P ₀	P ₁	W	W ₁
	(mm)	1.75 ± 0.10	3.50 ± 0.05	4.00 ± 0.10	4.00 ± 0.10	2.00 ± 0.05	8.00 ± 0.30	14.4 MAX.
	(inch)	0.069 ± 0.004	0.138 ± 0.002	0.157 ± 0.004	0.157 ± 0.004	0.079 ± 0.002	0.315 ± 0.012	0.567 MAX.

SMD ESD Protection Diode

Marking Code

Part Number	Marking Code
CPDT-12V	E12

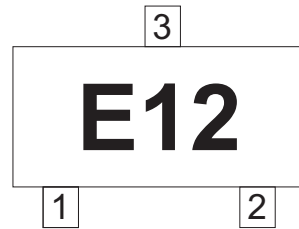

Suggested PAD Layout

SIZE	SOT-23	
	(mm)	(inch)
A	0.80	0.031
B	1.90	0.075
C	2.02	0.080
D	2.82	0.111

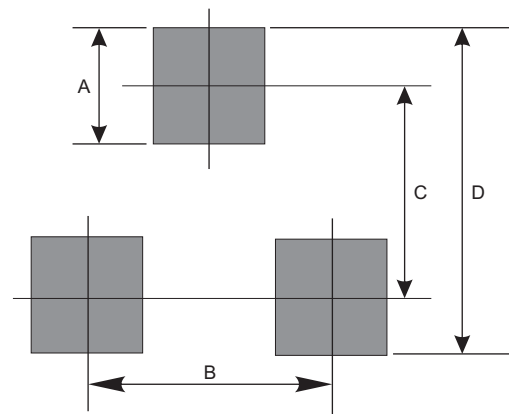

Standard Package

www.DataSheet4U.com

Case Type	Qty per Reel	Reel Size
	(Pcs)	(inch)
SOT-23	3000	7