



CPL-WB-00C2

Wide band directional coupler with ISO port

Features

- 50 Ω nominal input / output impedance
- Wide operating frequency range (824 MHz to 2170 MHz)
- Low Insertion Loss (< 0.2 dB)
- 34 dB typical coupling factor
- High directivity (typical 25 dB)
- High ESD robustness (IEC 61000-4-2 Level 4)
- Flip-Chip package
- Small footprint: 1700 x 1200 μm

Benefits

- Very low profile (< 690 μm thickness)
- Lead-free package
- High RF performance
- RF module size reduction

Applications

- Quad band power amplifier module
- Quad band front end module
- GSM / WCDMA mobile phone

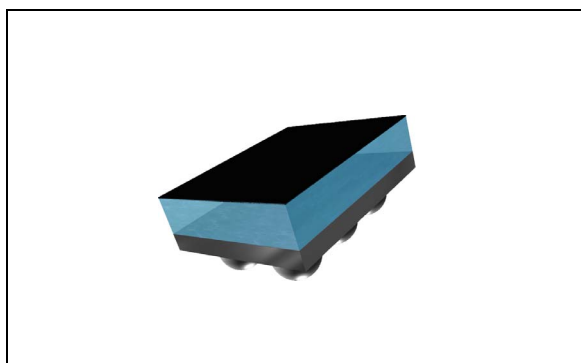
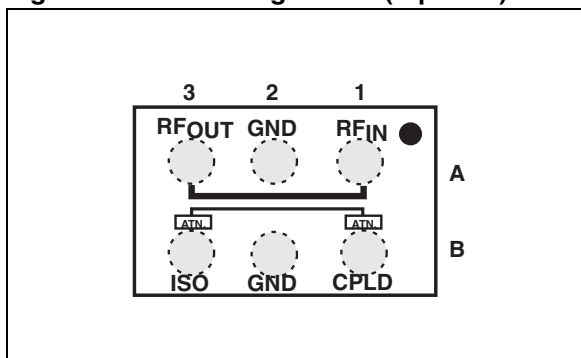

Figure 1. Pin configuration (top view)



Description

The CPL-WB-00 is a wide band directional coupler designed to measure RF antenna output power in GSM / WCDMA applications. This CPL has been customized for wide band operating frequencies (EGSM and CELL, PCS, DCS, WCDMA Band I) with less than 0.2 dB insertion losses in the transmit bandwidth (824 MHz to 1980 MHz).

The CPL-WB has been designed using STMicroelectronics IPD (integrated passive device) technology on non conductive glass substrate to optimize RF performance. The device is delivered 100% tested in tape and reel.

1 Characteristics

Table 1. Absolute maximum rating (limiting values)

Symbol	Parameter	Value			Unit
		Min	Typ	Max	
P_{IN}	Input Power RF_{IN}			35	dBm
V_{ESD} (IEC)	ESD ratings IEC 61000-4-2 (C = 150 pF, R = 330 Ω , 10 shots with both polarities and each condition, cumulative method)				
	RF_{IN} , RF_{OUT} , air discharge	± 15			kV
	RF_{IN} , RF_{OUT} , contact discharge	± 8			kV
V_{ESD} (HBM)	Human body model, JESD22-A114-B, All I/O	2			kV
V_{ESD} (MM)	Machine model, JESD22-A115-A, All I/O	100			V
V_{ESD} (CDM)	Charge device model, JESD22-C101-C, All I/O	500			V
T_{OP}	Operating temperature	-30		+85	$^{\circ}C$

Table 2. Electrical characteristics ($T_{amb} = 25^{\circ}C$) - impedances

Symbol	Parameter	Value			Unit
		Min	Typ	Max	
Z_{OUT}	Nominal output impedance		50		Ω
Z_{IN}	Nominal input impedance		50		Ω
Z_{CPLD}	Nominal coupling impedance		50		Ω
Z_{OUT}	Nominal ISO impedance		50		Ω

Table 3. Electrical characteristics ($T_{amb} = 25^{\circ}C$) - RF Performance

Symbol	Parameter	Test condition	Value			Unit
			Min	Typ	Max	
T_{OP}	Operating temperature		-30		+85	$^{\circ}C$
f	Frequency range (bandwidth)		824		1980	MHz
I_L	Insertion loss in bandwidth	From 824 MHz to 2170 MHz		0.1	0.2	dB
R_L	Return loss in bandwidth	From 824 MHz to 2170 MHz	15			dB
CPLD	Coupling factor (including attenuator)	From 824 MHz to 915 MHz	35		39	dB
		From 1710 MHz to 1980 MHz	28		33	dB
Ripple	Coupling ripple in individual band	(824 to 849 MHz) (880 to 915 MHz) (1710 to 1785 MHz) (1850 to 1910 MHz)(1920 to 1980 MHz)			0.5	dB
DIR	Coupler directivity	From 824 MHz to 1980 MHz	20	25		dB

1.1 RF measurement (on reference evaluation board)

Measurements done on reference evaluation board under 50 Ω , de-embedding at CPL00 bumps.

Figure 2. Insertion loss

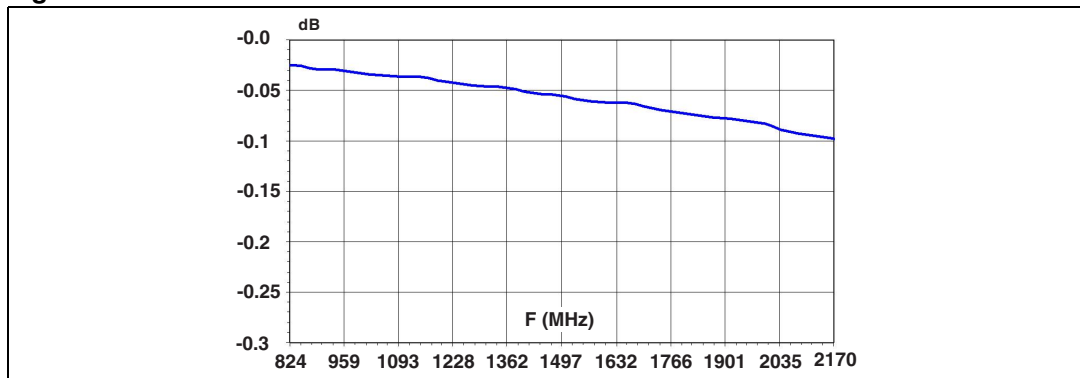

Figure 3. Coupling and isolation

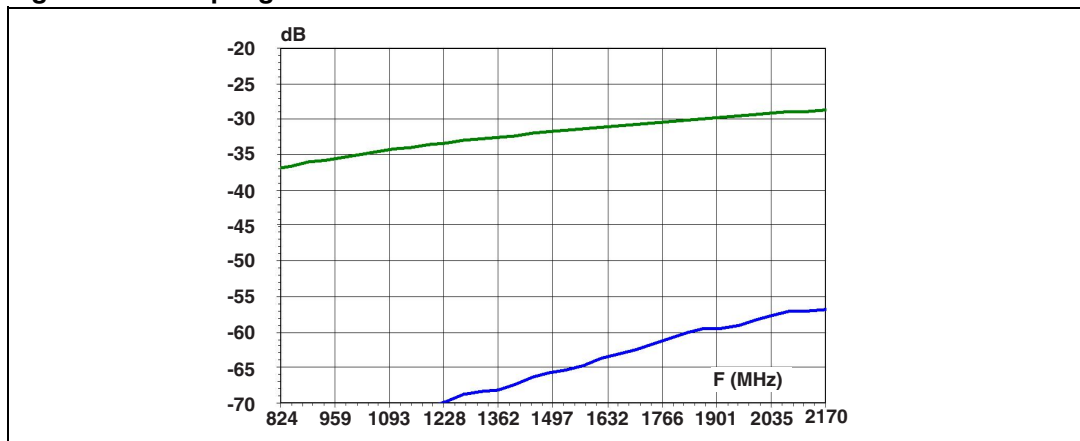
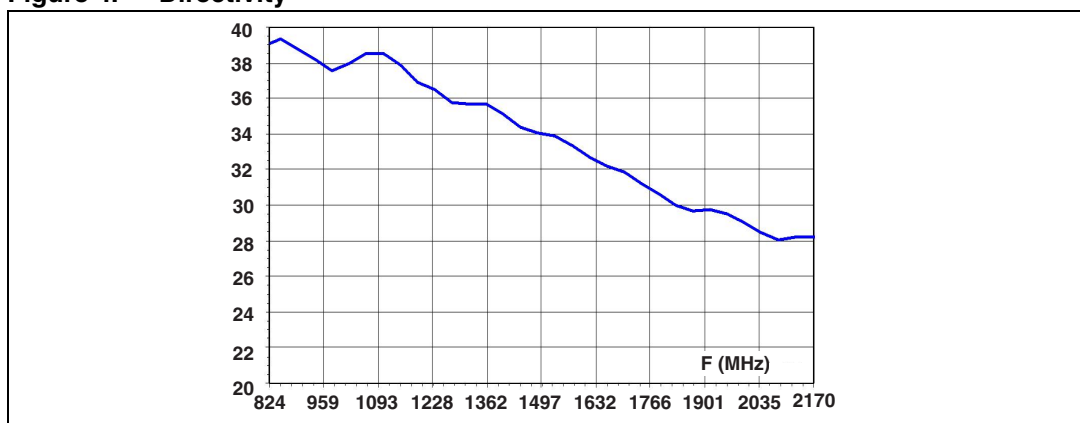
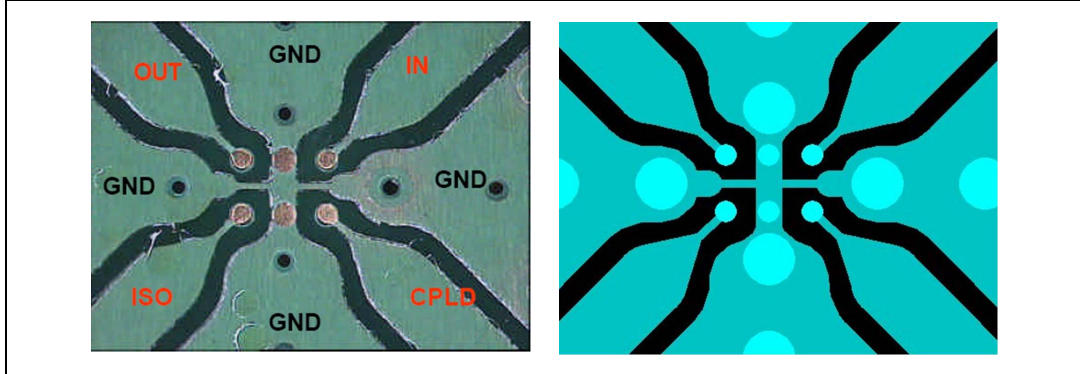

Figure 4. Directivity



2 Reference evaluation board

Figure 5. CPW lines ($W = 850 \mu\text{m}$ with gap to gnd = $260 \mu\text{m}$) on top layer + GND on bottom layer



- Material: 2 layers FR4 with solder mask on top and bottom layer
- Substrate thickness: 0.8 mm
- Line lengths: 10.2 mm
- Extension values on short line measurement: 102 ps
- Through insertion loss: 0.20 dB @ 1 GHz , 0.24 dB @ 2 GHz

3 Package information

In order to meet environmental requirements, ST offers these devices in ECOPACK® packages. These packages have a lead-free second level interconnect. The category of second level interconnect is marked on the inner box label, in compliance with JEDEC Standard JESD97. The maximum ratings related to soldering conditions are also marked on the inner box label. ECOPACK is an ST trademark. ECOPACK specifications are available at www.st.com.

Figure 6. Package dimensions

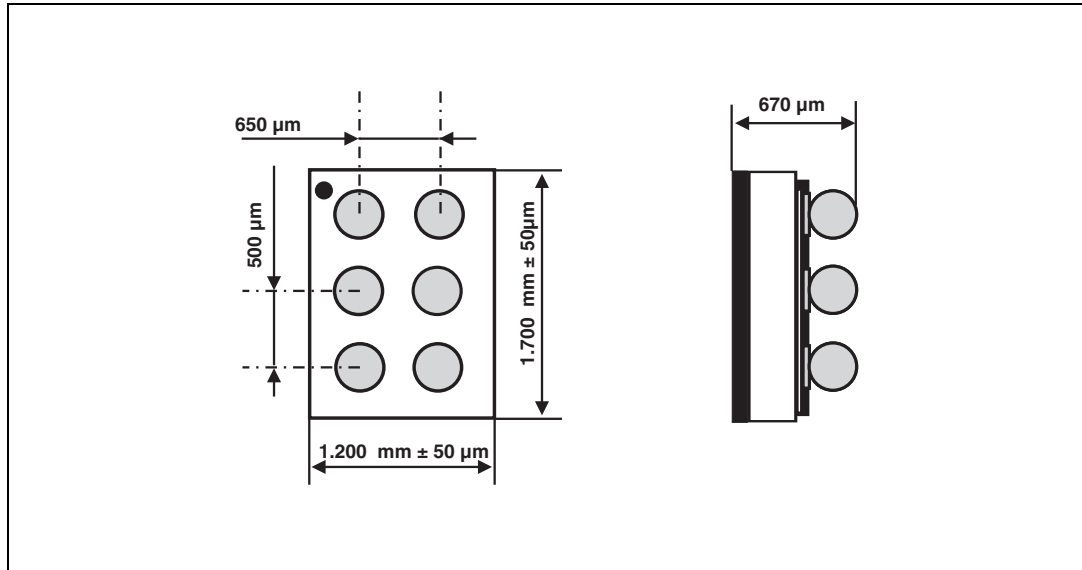

Figure 7. Footprint

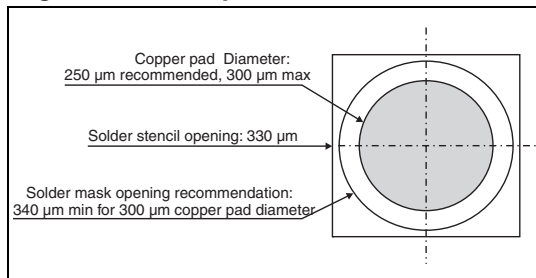

Figure 8. Marking

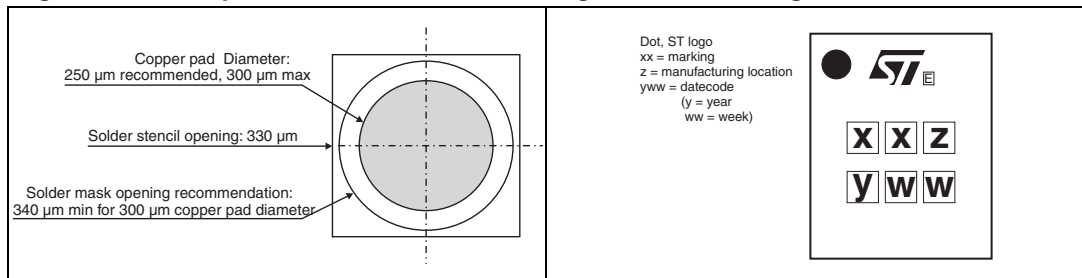
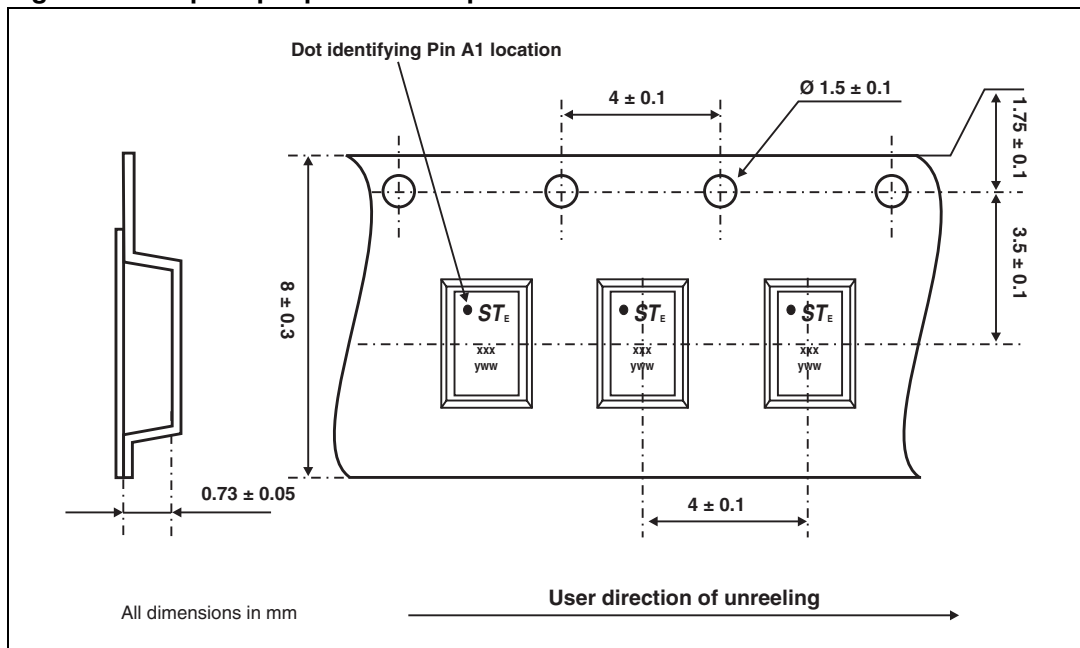

Figure 9. Flip Chip tape and reel specifications



Note:

More information is available in the application note:

AN1235: "Flip Chip: package description and recommendations for use"

4 Ordering information

Table 4. Ordering information

Order code	Marking	Base qty	Delivery mode
CPL-WB-00C2	RE	5000	Tape and reel

5 Revision history

Table 5. Document revision history

Date	Revision	Changes
02-Oct-2008	1	Initial release.

Please Read Carefully:

Information in this document is provided solely in connection with ST products. STMicroelectronics NV and its subsidiaries ("ST") reserve the right to make changes, corrections, modifications or improvements, to this document, and the products and services described herein at any time, without notice.

All ST products are sold pursuant to ST's terms and conditions of sale.

Purchasers are solely responsible for the choice, selection and use of the ST products and services described herein, and ST assumes no liability whatsoever relating to the choice, selection or use of the ST products and services described herein.

No license, express or implied, by estoppel or otherwise, to any intellectual property rights is granted under this document. If any part of this document refers to any third party products or services it shall not be deemed a license grant by ST for the use of such third party products or services, or any intellectual property contained therein or considered as a warranty covering the use in any manner whatsoever of such third party products or services or any intellectual property contained therein.

UNLESS OTHERWISE SET FORTH IN ST'S TERMS AND CONDITIONS OF SALE ST DISCLAIMS ANY EXPRESS OR IMPLIED WARRANTY WITH RESPECT TO THE USE AND/OR SALE OF ST PRODUCTS INCLUDING WITHOUT LIMITATION IMPLIED WARRANTIES OF MERCHANTABILITY, FITNESS FOR A PARTICULAR PURPOSE (AND THEIR EQUIVALENTS UNDER THE LAWS OF ANY JURISDICTION), OR INFRINGEMENT OF ANY PATENT, COPYRIGHT OR OTHER INTELLECTUAL PROPERTY RIGHT.

UNLESS EXPRESSLY APPROVED IN WRITING BY AN AUTHORIZED ST REPRESENTATIVE, ST PRODUCTS ARE NOT RECOMMENDED, AUTHORIZED OR WARRANTED FOR USE IN MILITARY, AIR CRAFT, SPACE, LIFE SAVING, OR LIFE SUSTAINING APPLICATIONS, NOR IN PRODUCTS OR SYSTEMS WHERE FAILURE OR MALFUNCTION MAY RESULT IN PERSONAL INJURY, DEATH, OR SEVERE PROPERTY OR ENVIRONMENTAL DAMAGE. ST PRODUCTS WHICH ARE NOT SPECIFIED AS "AUTOMOTIVE GRADE" MAY ONLY BE USED IN AUTOMOTIVE APPLICATIONS AT USER'S OWN RISK.

Resale of ST products with provisions different from the statements and/or technical features set forth in this document shall immediately void any warranty granted by ST for the ST product or service described herein and shall not create or extend in any manner whatsoever, any liability of ST.

ST and the ST logo are trademarks or registered trademarks of ST in various countries.

Information in this document supersedes and replaces all information previously supplied.

The ST logo is a registered trademark of STMicroelectronics. All other names are the property of their respective owners.

© 2008 STMicroelectronics - All rights reserved

STMicroelectronics group of companies

Australia - Belgium - Brazil - Canada - China - Czech Republic - Finland - France - Germany - Hong Kong - India - Israel - Italy - Japan - Malaysia - Malta - Morocco - Singapore - Spain - Sweden - Switzerland - United Kingdom - United States of America

www.st.com