

# MODEL NUMBER CPS0827

## Phase Shifter 4 Section

### FEATURES

- 1215-1400 MHz
- 22.5° LSB, 337.5° Range
- +35 dBm 3rd Order Intercept
- TTL Driver
- Replaceable SMA Connectors

4 BIT

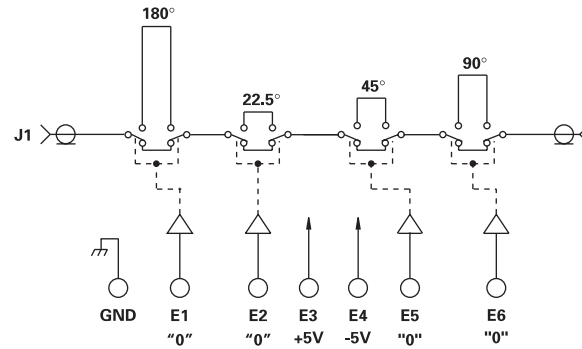
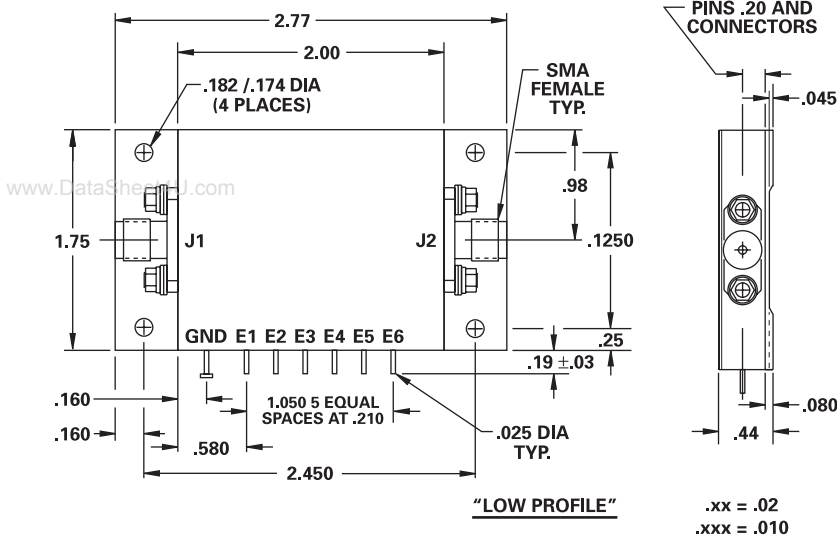

### GUARANTEED PERFORMANCE

Parameter	Min	Typ	Max	Units	Conditions
Operating Frequency	1215		1400	MHz	
DC Current		83	250	mA	At +5 VDC Supply
		40	250	mA	At -5 VDC Supply
Control Type		TTL			4 Line Logic "0" = Reference Logic "1" = Phase Shift
Control Current	High	0	±20	µA	V <sub>IH</sub> = +2.7 V
	Low	0	±20	µA	V <sub>IL</sub> = +0.5 V
Insertion Loss	1.0	2.18	2.50	dB	At +25° C
	0.75	2.47	2.75	dB	At Temperature Extremes
Amplitude Stability		0.35	0.60	dB	Vs. Phase Shift
Time Delay	500	850	900	pSec	
Phase	LSB	22.5		DEG	22.5, 45, 90, 180 At 1215 MHz
	Range	0	337.5	DEG	
	Accuracy		±10	DEG	
	Linearity		1.5	3.0	DEG
VSWR		1.2/1	1.5/1		
Impedance		50		OHMS	
Switching Speed		145	500	nSec	50% TTL to 90% / 10% RF
Transition (Rise/Fall) Time		105		nSec	90% / 10% or 10% / 90% RF
Switching (Video) Transients		135		mV	Peak Value
Intercept Points	2nd	+60		dBm	575 MHz / 400 MHz
	3rd	+35		dBm	287.5 MHz / 400 MHz
RF Power	Operate	+22	+20	dBm	0.2 dB Compression
	No Damage		+30	dBm	
Operating Temperature	-54	+25	+80	°C	TA