

# CARBON FILM RESISTORS CR-S/FCR-S SERIES

## Feature

- Space save on PC board
- Excellent long term stability
- Cost comparable to conventional sizes
- Standard Value: 10R-10Meg in E24 series
- Standard tolerance: +/-5% (available +/-2%)
- Flameproof coating available (As FCR-S type)
- Operating Temperature : -55°C ~+125°C

## Material

Element: Deposited Carbon Film  
 Core: High Purity Ceramic Al<sub>2</sub>O<sub>3</sub>  
 Termination: Standard solder-plated copper lead  
 Coating: Epoxy, (FCR-S is grey silicone)

## Dimension

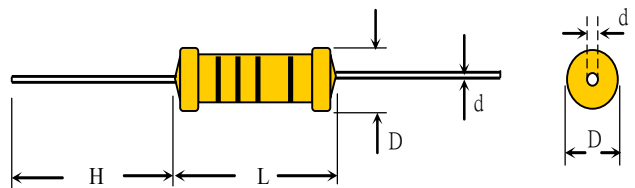

## General Specification

TYPE	DIMENSION(mm)				POWER RATING	MAXIMUM WORKING VOLTAGE	MAXIMUM OVERLOAD VOLTAGE	RESISTANCE RANGE ± 5%
	L	D	H	d±0.05				
CR025S	3.2±0.2	1.6±0.2	27 +/-3.0	0.45	1/4W	250V	500V	0.47Ω-22MΩ
CR050S	6.0±0.5	2.3±0.3	27 +/-3.0	0.55	1/2W	350V	700V	0.47Ω-22MΩ
CR100S	9.0±0.5	3.0±0.5	27 +/-3.0	0.64	1W	500V	1000V	0.47Ω-22MΩ
CR200S	11±1.0	4.0±0.5	33 +/- 3.0	0.75	2W	500V	1000V	0.47Ω-22MΩ
CR300S	15±1.0	5.0±0.5	33 +/- 3.0	0.75	3W	500V	1000V	0.47Ω-22MΩ

\* Maximum Working Voltage determined by  $E=\sqrt{P \cdot R}$ , where E should not exceed value listed in column above.

\*\*Maximum Overload Voltage equals to 2.5XE, but should not exceed value listed in column above.

## Derating Curve

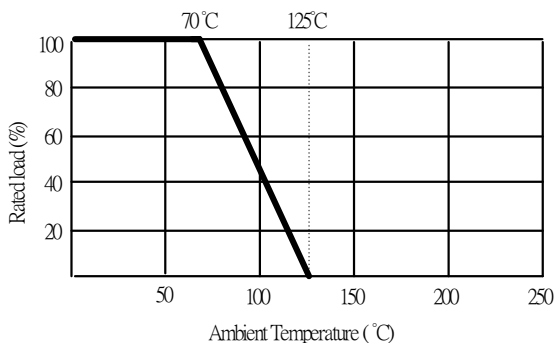

## Temperature Rise

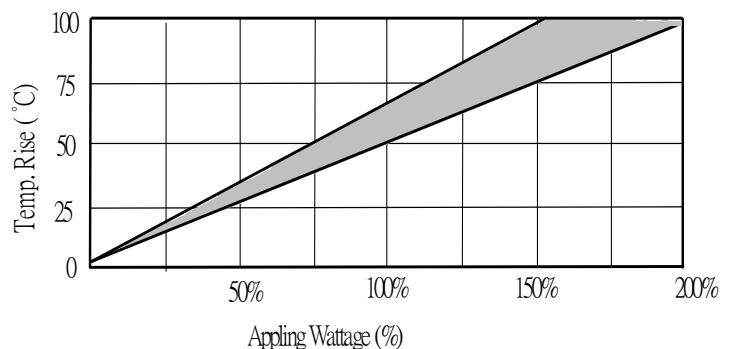

# CARBON FILM RESISTORS CR-S/FCR-S SERIES

## Characteristics

Item	Requirement	Test Method
Short Time Overload	$\pm(0.75\%+0.05\Omega)$	JIS-C-5201-1 5.5 RCWV*2.5 or Max. overload voltage for 5 seconds
Insulation Resistance	$> 1000M\Omega$	JIS-C-5201-1 5.6 Apply 100VDC for 1 minute
Endurance	$\pm(3\%+0.05\Omega)$	JIS-C-5201-1 7.10 70 $\pm$ 2 $^{\circ}$ C, Max. RCWV for 1000 hrs with 1.5 hrs "ON" and 0.5hrs "OFF"
Damp Heat with Load	$\leq 100K\Omega \pm 3\%$ $\geq 100K\Omega \pm 5\%$	JIS-C-5201-1 7.9 40 $\pm$ 2 $^{\circ}$ C, 90~95% R.H. RCWV for 1000 hrs with 1.5 hrs "ON" and 0.5hrs "OFF"
Solderability	90% min. Coverage	JIS-C-5201-1 6.5 245 $\pm$ 5 $^{\circ}$ C for 3 seconds
Dielectric Withstanding Voltage	By Type	JIS-C-5201-1 5.7 Apply Max. Overload Voltage for 1 minute
Temperature Coefficient	$< 100K\Omega +350ppm\sim 500ppm$ $100K\Omega\sim 1M\Omega -0ppm\sim 700ppm$ $> 1 M\Omega -0ppm\sim 1500ppm$	Resistance value at room temperature and room Temperature+100 $^{\circ}$ C
Pulse Overload	$\pm(1\%+0.05\Omega)$	JIS-C-5201-1 5.8 4 times RCWV for 10000 cycles with 1 second "ON" and 25 seconds "OFF"
Resistance To Solvent	No deterioration of coatings and markings	JIS-C-5201-1 6.9 Trichroethane for 1 min. with ultrasonic
Terminal Strength	Tensile: $\geq 2.5$ kg	Direct Load for 10 seconds In the direction off the terminal leads

**\*Storage Temperature : 25 $\pm$ 3 $^{\circ}$ C ; Humidity < 80%RH**

## Part Numbering

<b>CR025S</b>	<b>J</b>	<b>TB</b>	=	<b>10R</b>
↓	↓	↓		↓
Type/Power	Tol.	Package		Resistance
CR025S	J= $\pm$ 5%	B=Bulk		10R = 10 $\Omega$
CR050S		TB=Tape/box		1K2R= 1.2K $\Omega$
CR100S		TR=Tape/reel		1MR= 1M $\Omega$
CR200S		Lead forming		
CR300S		M		
		F		
		MB		

# CARBON FILM RESISTORS CR-S/FCR-S SERIES

## Taping/Packing Specification

**Packing Methods**

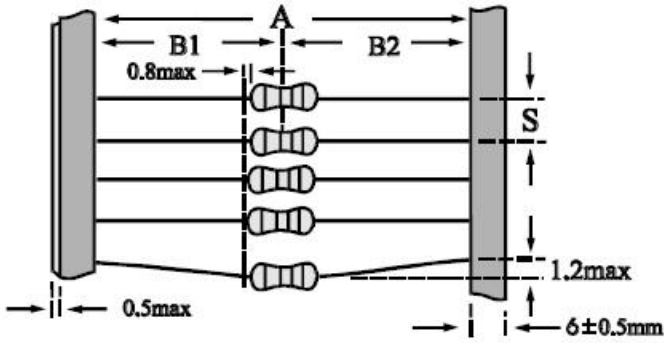

**Reel Packing**

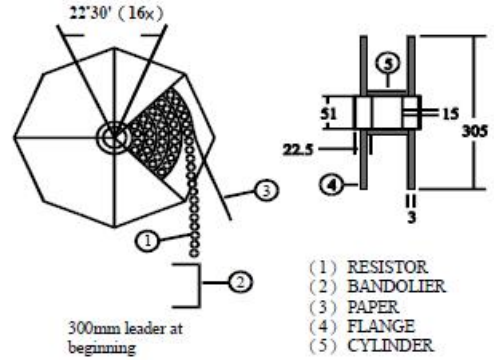

TYPE	PACKING METHOD			REEL PACKING	
	A	B1-B2	S	Across Flange (A)	Q'TY
		Max			
CR025S	52+1/-0	1.2	5	72	5000
CR050S	52+1/-0	1.2	5	72	5000
CR100S	52+1/-0	1.2	5	72	2000
CR200S	52+1/-0	1.2	5	72	1000
	73+1/-0	1.5	5	72	1000
CR300S	52+1/-0	1.2	10	95	1000
	73+1/-0	1.5	10	95	1000

**Ammo Packing**

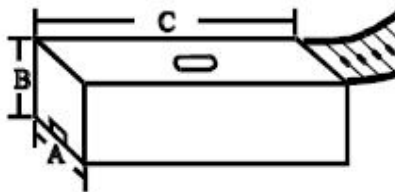

	PACKING METHOD			AMMO PACKING			
	A	B1-B2	S	A	B	C	Q'TY
		Max					
CR025S	52+1/-0	1.2	5	80	68	255	5000
CR050S	52+1/-0	1.2	5	75	22	267	1000
		1.2	5	85	103	263	5000
CR100S	52+1/-0	1.2	5	85	95	263	2000
CR200S	52+1/-0, 73+1/-0	1.2, 1.5	5	85,103	102,85	263	1000
CR300S	52+1/-0, 73+1/-0	1.2, 1.5	10	85, 103	102,95	265	1000