



# CS42L52

## Low Power, Stereo CODEC w/Headphone & Speaker Amps

### Stereo CODEC

- ◆ High Performance Stereo ADC & DAC
  - 98 dB Dynamic Range (A-wtd)
  - -88 dB THD+N
- ◆ Flexible Stereo Analog Input Architecture
  - 4:1 Analog Input MUX
  - Analog Input Mixing
  - Analog Passthru with Volume Control
  - Analog Programmable Gain Amplifier (PGA)
- ◆ Programmable Automatic Level Control (ALC)
  - Noise Gate for Noise Suppression
  - Programmable Threshold & Attack/Release Rates
- ◆ Dual MIC Inputs
  - Differential or Single-Ended
  - +16 dB to +32 dB w/1dB step MIC Pre-Amplifiers
  - Programmable, Low Noise MIC Bias Levels
- ◆ Digital Signal Processing Engine
  - Bass & Treble Tone Control, De-Emphasis
  - Master Vol. and Independent PCM SDIN + ADC SDOOUT Mix Volume Control
  - Soft-Ramp & Zero-Cross Transitions
  - Programmable Peak-Detect and Limiter
  - Beep Generator w/Full Tone Control

### Class D Stereo/Mono Speaker Amplifier

- ◆ No External Filter Required
- ◆ High Stereo Output Power at 10% THD+N
  - 2 x 1.00 W into 8  $\Omega$  @ 5.0 V
  - 2 x 550 mW into 8  $\Omega$  @ 3.7 V
  - 2 x 230 mW into 8  $\Omega$  @ 2.5 V
- ◆ High Mono Output Power at 10% THD+N
  - 1 x 1.90 W into 4  $\Omega$  @ 5.0 V
  - 1 x 1.00 W into 4  $\Omega$  @ 3.7 V
  - 1 x 350 mW into 4  $\Omega$  @ 2.5 V
- ◆ Direct Battery Powered Operation
  - Battery Level Monitoring & Compensation
- ◆ 82% Efficiency at 800 mW
- ◆ Phase-Aligned PWM Output Reduces Idle Channel Current
- ◆ Spread Spectrum Modulation
- ◆ Low Quiescent Current

### Stereo Headphone Amplifier

- ◆ Ground Centered Outputs
  - No DC-Blocking Capacitors Required
  - Integrated Negative Voltage Regulator
- ◆ High Power Output at -75 dB THD+N
  - 2 x 23 mW Into 16  $\Omega$  @ 1.8 V
  - 2 x 44 mW Into 16  $\Omega$  @ 2.5 V

(Features continued on [page 2](#))

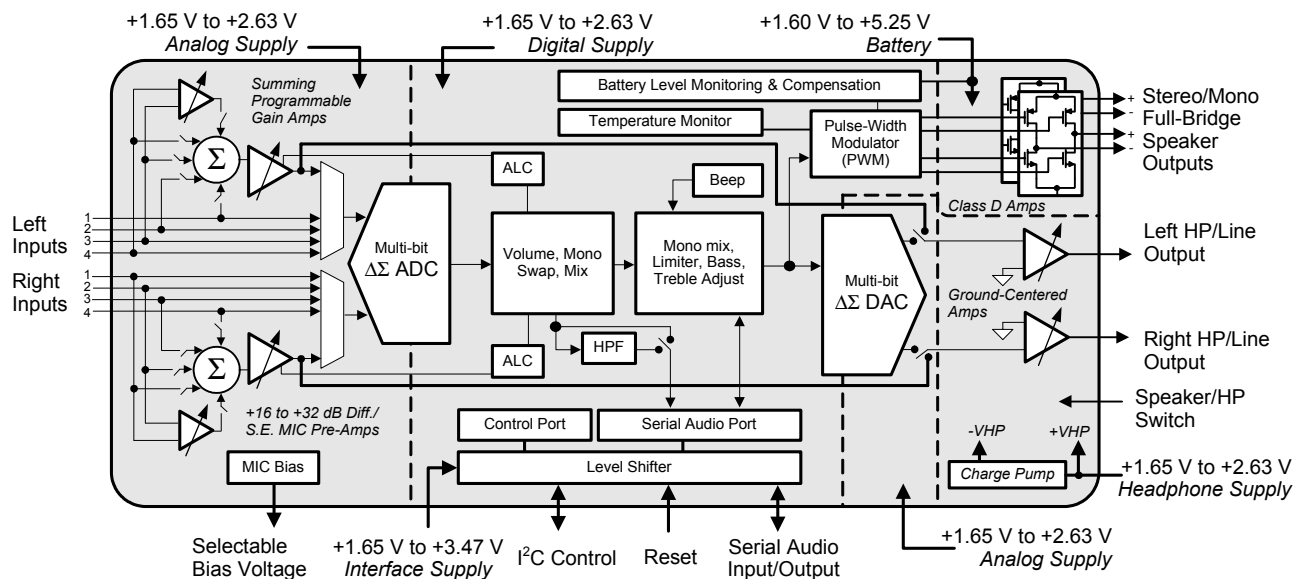

Advance Product Information

This document contains information for a new product. Cirrus Logic reserves the right to modify this product without notice.

## System Features

- ◆ 12, 24, and 27 MHz Master Clock Support in Addition to Typical Audio Clock Rates
- ◆ High Performance 24-bit Converters
  - Multi-bit Delta Sigma Architecture
  - Very Low 64Fs Oversampling Clock Reduces Power Consumption
- ◆ Low Power Operation
  - Stereo Analog Passthru: 10 mW @ 1.8 V
  - Stereo Playback: 14 mW @ 1.8 V
  - Stereo Rec. and Playback: 23 mW @ 1.8 V
- ◆ Variable Power Supplies
  - 1.8 V to 2.5 V Digital & Analog
  - 1.6 V to 5 V Class D Amplifier
  - 1.8 V to 2.5 V Headphone Amplifier
  - 1.8 V to 3.3 V Interface Logic
- ◆ Power Down Management
  - ADC, DAC, CODEC, MIC Pre-Amplifier, PGA, Headphone Amplifier, Speaker Amplifier
- ◆ Analog & Digital Routing/Mixes:
  - Line/Headphone Out = Analog In (ADC Bypassed)
  - Line/Headphone/Speaker Out = ADC + Digital In
  - Digital Out = ADC + Digital In
  - Internal Digital Loopback
  - Mono Mixes
- ◆ Flexible Clocking Options
  - Master or Slave Operation
  - High Impedance Digital Output Option (for easy MUXing between CODEC & other data sources)
  - Quarter-Speed Mode - (i.e. allows 8 kHz Fs while maintaining a flat noise floor up to 16 kHz)
  - 4 kHz to 96 kHz Sample Rates
- ◆ I<sup>2</sup>C<sup>®</sup> Control Port Operation
- ◆ Temp. Monitor w/Thermal Foldback & Shutdown
- ◆ Headphone/Speaker Detection Input
- ◆ Pop and Click Suppression

## Applications

- ◆ Digital Voice Recorders, Digital Cameras & Camcorders
- ◆ PDA's
- ◆ Personal Media Players
- ◆ Portable Game Consoles

## General Description

The CS42L52 is a highly integrated, low power stereo CODEC with headphone and Class D speaker amplifiers. The CS42L52 offers many features suitable for low power, portable system applications.

The **ADC input path** allows independent channel control of a number of features. Input summing amplifiers mix and select line-level and/or microphone level inputs for each channel. The microphone input path includes a selectable programmable-gain pre-amplifier stage and a low noise MIC bias voltage supply. A PGA is available for line or microphone inputs and provides analog gain with soft ramp and zero cross transitions. The ADC also features a digital volume control with soft ramp transitions. A programmable ALC and Noise Gate monitor the input signals and adjust the volume levels appropriately. To conserve power, the ADC may be bypassed while still allowing full analog volume control.

The **DAC output path** includes a digital signal processing engine with various fixed function controls. Tone Control provides bass and treble adjustment of four selectable corner frequencies. The Digital Mixer provides independent volume control for both the ADC output and PCM input signal paths, as well as a master volume control. Digital Volume controls may be configured to change on soft ramp transitions while the analog controls can be configured to occur on every zero crossing. The DAC also includes de-emphasis, limiting functions and a BEEP generator delivering tones selectable across a range of two full octaves.

The **stereo headphone amplifier** is powered from a separate positive supply and the integrated **charge pump** provides a negative supply. This allows a ground-centered analog output with a wide signal swing and eliminates external DC-blocking capacitors.

The **Class D stereo speaker amplifier** does not require an external filter and provides the high efficiency amplification required by power sensitive portable applications. The speaker amplifier may be powered directly from a battery while the internal DC supply monitoring and compensation provides a constant gain level as the battery's voltage decays. An internal **temperature monitor** alerts the user and automatically attenuates and/or shuts down the PWM speaker output when an overload condition causes temperatures to exceed safe operating levels.

In addition to its many features, the CS42L52 operates from a low voltage analog and digital core making it ideal for portable systems that require extremely low power consumption in a minimal amount of space.

The CS42L52 is available in a 40-pin QFN package in both Commercial (-40 to +85 °C) and Automotive (-40 to +105 °C) grades. The CS42L52 Customer Demonstration board is also available for device evaluation and implementation suggestions. Please refer to "[Ordering Information](#)" on page 82 for complete ordering information.

---

**TABLE OF CONTENTS**

<b>1. PIN DESCRIPTIONS</b> .....	<b>8</b>
1.1 I/O Pin Characteristics .....	9
<b>2. TYPICAL CONNECTION DIAGRAM</b> .....	<b>10</b>
<b>3. CHARACTERISTIC AND SPECIFICATIONS</b> .....	<b>11</b>
RECOMMENDED OPERATING CONDITIONS .....	11
ABSOLUTE MAXIMUM RATINGS .....	11
ANALOG INPUT CHARACTERISTICS (COMMERCIAL - CNZ) .....	12
ANALOG INPUT CHARACTERISTICS (AUTOMOTIVE - DNZ) .....	13
ADC DIGITAL FILTER CHARACTERISTICS .....	14
ANALOG OUTPUT CHARACTERISTICS (COMMERCIAL - CNZ) .....	15
ANALOG OUTPUT CHARACTERISTICS (AUTOMOTIVE - DNZ) .....	16
ANALOG PASSTHRU CHARACTERISTICS .....	17
PWM OUTPUT CHARACTERISTICS (Note 9) .....	17
LINE OUTPUT VOLTAGE LEVEL CHARACTERISTICS .....	18
HEADPHONE OUTPUT POWER CHARACTERISTICS .....	19
COMBINED DAC INTERPOLATION & ON-CHIP ANALOG FILTER RESPONSE .....	20
SWITCHING SPECIFICATIONS - SERIAL PORT .....	21
SWITCHING SPECIFICATIONS - I <sup>2</sup> C CONTROL PORT .....	22
DC ELECTRICAL CHARACTERISTICS .....	23
DIGITAL INTERFACE SPECIFICATIONS & CHARACTERISTICS .....	23
POWER CONSUMPTION .....	24
<b>4. APPLICATIONS</b> .....	<b>25</b>
4.1 Overview .....	25
4.1.1 Basic Architecture .....	25
4.1.2 Line & MIC Inputs .....	25
4.1.3 Line & Headphone Outputs .....	25
4.1.4 Speaker Driver Outputs .....	25
4.1.5 Fixed Function DSP Engine .....	25
4.1.6 Beep Generator .....	25
4.1.7 Power Management .....	25
4.2 Analog Inputs .....	26
4.2.1 MIC Inputs .....	27
4.2.2 Automatic Level Control (ALC) .....	27
4.2.3 Noise Gate .....	28
4.3 Analog Outputs .....	29
4.3.1 Beep Generator .....	30
4.3.2 Limiter .....	31
4.4 Analog In to Analog Out Passthru .....	32
4.4.1 Overriding the ADC Power Down .....	32
4.4.2 Overriding the PGA Power Down .....	33
4.5 PWM Outputs .....	33
4.5.1 Mono Speaker Output Configuration .....	33
4.5.2 VP Battery Compensation .....	33
4.5.2.1 Maintaining a Desired Output Level .....	34
4.6 Serial Port Clocking .....	34
4.7 Digital Interface Formats .....	36
4.7.1 DSP Mode .....	36
4.8 Initialization .....	36
4.9 Recommended Power-Up Sequence .....	37
4.10 Recommended Power-Down Sequence .....	37
4.11 Control Port Operation .....	38
4.11.1 I <sup>2</sup> C Control .....	38

4.11.2 Memory Address Pointer (MAP) .....	39
4.11.2.1 Map Increment (INCR) .....	39
<b>5. REGISTER QUICK REFERENCE .....</b>	<b>40</b>
<b>6. REGISTER DESCRIPTION .....</b>	<b>42</b>
6.1 Chip I.D. and Revision Register (Address 01h) (Read Only) .....	42
6.1.1 Chip I.D. (Read Only) .....	42
6.1.2 Chip Revision (Read Only) .....	42
6.2 Power Control 1 (Address 02h) .....	42
6.2.1 Power Down ADC Charge Pump .....	42
6.2.2 Power Down PGAx .....	42
6.2.3 Power Down ADCx .....	43
6.2.4 Power Down .....	43
6.3 Power Control 2 (Address 03h) .....	43
6.3.1 Power Down ADC Override .....	43
6.3.2 Power Down MICx .....	43
6.3.3 Power Down MIC Bias .....	43
6.4 Power Control 3 (Address 04h) .....	44
6.4.1 Headphone Power Control .....	44
6.4.2 Speaker Power Control .....	44
6.5 Clocking Control (Address 05h) .....	44
6.5.1 Auto-Detect .....	44
6.5.2 Speed Mode .....	45
6.5.3 32kHz Sample Rate Group .....	45
6.5.4 27 MHz Video Clock .....	45
6.5.5 Internal MCLK/LRCK Ratio .....	45
6.5.6 MCLK Divide By 2 .....	46
6.6 Interface Control 1 (Address 06h) .....	46
6.6.1 Master/Slave Mode .....	46
6.6.2 SCLK Polarity .....	46
6.6.3 ADC Interface Format .....	46
6.6.4 DSP Mode .....	46
6.6.5 DAC Interface Format .....	47
6.6.6 Audio Word Length .....	47
6.7 Interface Control 2 (Address 07h) .....	47
6.7.1 SCLK equals MCLK .....	47
6.7.2 SDOUT to SDIN Digital Loopback .....	47
6.7.3 Tri-State Serial Port Interface .....	48
6.7.4 Speaker/Headphone Switch Invert .....	48
6.7.5 MIC Bias Level .....	48
6.8 Input x Select: ADCA and PGAA (Address 08h), ADCB and PGAB (Address 09h) .....	48
6.8.1 ADC Input Select .....	48
6.8.2 PGA Input Mapping .....	49
6.9 Analog & HPF Control (Address 0Ah) .....	49
6.9.1 ADCx High-Pass Filter .....	49
6.9.2 ADCx High-Pass Filter Freeze .....	49
6.9.3 Ch. x Analog Soft Ramp .....	49
6.9.4 Ch. x Analog Zero Cross .....	49
6.10 ADC HPF Corner Frequency (Address 0Bh) .....	50
6.10.1 HPF x Corner Frequency .....	50
6.11 Misc. ADC Control (Address 0Ch) .....	50
6.11.1 ADC Channel B=A .....	50
6.11.2 Digital MUX .....	50
6.11.3 Digital Sum .....	50
6.11.4 Invert ADC Signal Polarity .....	50

6.11.5 ADC Mute .....	51
6.12 Playback Control 1 (Address 0Dh) .....	51
6.12.1 Headphone Analog Gain .....	51
6.12.2 Playback Volume Setting B=A .....	51
6.12.3 Invert PCM Signal Polarity .....	51
6.12.4 Master Playback Mute .....	51
6.13 Miscellaneous Controls (Address 0Eh) .....	52
6.13.1 Passthru Analog .....	52
6.13.2 Passthru Mute .....	52
6.13.3 Freeze Registers .....	52
6.13.4 HP/Speaker De-Emphasis .....	52
6.13.5 Digital Soft Ramp .....	53
6.13.6 Digital Zero Cross .....	53
6.14 Playback Control 2 (Address 0Fh) .....	53
6.14.1 Headphone Mute .....	53
6.14.2 Speaker Mute .....	53
6.14.3 Speaker Volume Setting B=A .....	54
6.14.4 Speaker Channel Swap .....	54
6.14.5 Speaker MONO Control .....	54
6.14.6 Speaker Mute 50/50 Control .....	54
6.15 MICx Amp Control:	
MIC A (Address 10h) & MIC B (Address 11h) .....	54
6.15.1 MIC x Select .....	54
6.15.2 MICx Configuration .....	55
6.15.3 MICx Gain .....	55
6.16 PGAx Vol. & ALCx Transition Ctl.:	
ALC, PGA A (Address 12h) & ALC, PGA B (Address 13h) .....	55
6.16.1 ALCx Soft Ramp Disable .....	55
6.16.2 ALCx Zero Cross Disable .....	55
6.16.3 PGAx Volume .....	56
6.17 Passthru x Volume: PASSAVOL (Address 14h) & PASSBVOL (Address 15h) .....	56
6.17.1 Passthru x Volume .....	56
6.18 ADCx Volume Control: ADCAVOL (Address 16h) & ADCBVOL (Address 17h) .....	57
6.18.1 ADCx Volume .....	57
6.19 ADCx Mixer Volume: ADCA (Address 18h) & ADCB (Address 19h) .....	58
6.19.1 ADC Mixer Channel x Mute .....	58
6.19.2 ADC Mixer Channel x Volume .....	58
6.20 PCMx Mixer Volume: PCMA (Address 1Ah) & PCMB (Address 1Bh) .....	58
6.20.1 PCM Mixer Channel x Mute .....	58
6.20.2 PCM Mixer Channel x Volume .....	58
6.21 Beep Frequency & On Time (Address 1Ch) .....	59
6.21.1 Beep Frequency .....	59
6.21.2 Beep On Time .....	60
6.22 Beep Volume & Off Time (Address 1Dh) .....	60
6.22.1 Beep Off Time .....	60
6.22.2 Beep Volume .....	61
6.23 Beep & Tone Configuration (Address 1Eh) .....	61
6.23.1 Beep Configuration .....	61
6.23.2 Beep Mix Disable .....	61
6.23.3 Treble Corner Frequency .....	62
6.23.4 Bass Corner Frequency .....	62
6.23.5 Tone Control Enable .....	62
6.24 Tone Control (Address 1Fh) .....	62
6.24.1 Treble Gain .....	62

6.24.2 Bass Gain .....	63
6.25 Master Volume Control: MSTA (Address 20h) & MSTB (Address 21h) .....	63
6.25.1 Master Volume Control .....	63
6.26 Headphone Volume Control: HPA (Address 22h) & HPB (Address 23h) .....	63
6.26.1 Headphone Volume Control .....	63
6.27 Speaker Volume Control: SPKA (Address 24h) & SPKB (Address 25h) .....	64
6.27.1 Speaker Volume Control .....	64
6.28 ADC & PCM Channel Mixer (Address 26h) .....	64
6.28.1 PCM Mix Channel Swap .....	64
6.28.2 ADC Mix Channel Swap .....	64
6.29 Limiter Control 1, Min/Max Thresholds (Address 27h) .....	65
6.29.1 Limiter Maximum Threshold .....	65
6.29.2 Limiter Cushion Threshold .....	65
6.29.3 Limiter Soft Ramp Disable .....	65
6.29.4 Limiter Zero Cross Disable .....	66
6.30 Limiter Control 2, Release Rate (Address 28h) .....	66
6.30.1 Peak Detect and Limiter .....	66
6.30.2 Peak Signal Limit All Channels .....	66
6.30.3 Limiter Release Rate .....	66
6.31 Limiter Attack Rate (Address 29h) .....	67
6.31.1 Limiter Attack Rate .....	67
6.32 ALC Enable & Attack Rate (Address 2Ah) .....	67
6.32.1 ALCx Enable .....	67
6.32.2 ALC Attack Rate .....	67
6.33 ALC Release Rate (Address 2Bh) .....	68
6.33.1 ALC Release Rate .....	68
6.34 ALC Threshold (Address 2Ch) .....	68
6.34.1 ALC Maximum Threshold .....	68
6.34.2 ALC Minimum Threshold .....	69
6.35 Noise Gate Control (Address 2Dh) .....	69
6.35.1 Noise Gate All Channels .....	69
6.35.2 Noise Gate Enable .....	69
6.35.3 Noise Gate Threshold and Boost .....	70
6.35.4 Noise Gate Delay Timing .....	70
6.36 Status (Address 2Eh) (Read Only) .....	70
6.36.1 Serial Port Clock Error (Read Only) .....	70
6.36.2 DSP Engine Overflow (Read Only) .....	71
6.36.3 PCMx Overflow (Read Only) .....	71
6.36.4 ADCx Overflow (Read Only) .....	71
6.37 Battery Compensation (Address 2Fh) .....	71
6.37.1 Battery Compensation .....	71
6.37.2 VP Monitor .....	71
6.37.3 VP Reference .....	72
6.38 VP Battery Level (Address 30h) (Read Only) .....	72
6.38.1 VP Voltage Level (Read Only) .....	72
6.39 Speaker Status (Address 31h) (Read Only) .....	72
6.39.1 Speaker Current Load Status (Read Only) .....	72
6.39.2 SPKR/HP Pin Status (Read Only) .....	73
6.39.3 Thermal Warning Status (Read Only) .....	73
6.39.4 Thermal Error Status (Read Only) .....	73
6.40 Temperature Monitor Control (Address 32h) .....	73
6.40.1 Temperature Acknowledge & Release .....	73
6.40.2 Thermal Foldback (Address 33h) .....	73
6.40.3 Thermal Foldback .....	73



6.40.4 Speaker Attenuation .....	74
6.41 Charge Pump Frequency (Address 34h) .....	74
6.41.1 Charge Pump Frequency .....	74
<b>7. ANALOG PERFORMANCE PLOTS .....</b>	<b>75</b>
7.1 Headphone THD+N versus Output Power Plots .....	75
<b>8. EXAMPLE SYSTEM CLOCK FREQUENCIES .....</b>	<b>77</b>
8.1 Auto Detect Enabled .....	77
8.2 Auto Detect Disabled .....	77
<b>9. PCB LAYOUT CONSIDERATIONS .....</b>	<b>78</b>
9.1 Power Supply, Grounding .....	78
9.2 QFN Thermal Pad .....	78
<b>10. ADC &amp; DAC DIGITAL FILTERS .....</b>	<b>79</b>
<b>11. PARAMETER DEFINITIONS .....</b>	<b>80</b>
<b>12. PACKAGE DIMENSIONS .....</b>	<b>81</b>
THERMAL CHARACTERISTICS .....	81
<b>13. ORDERING INFORMATION .....</b>	<b>82</b>
<b>14. REFERENCES .....</b>	<b>82</b>
<b>15. REVISION HISTORY .....</b>	<b>82</b>

## LIST OF FIGURES

Figure 1. Typical Connection Diagram .....	10
Figure 2. Headphone Output Test Load .....	19
Figure 3. Serial Audio Interface Timing .....	21
Figure 4. Control Port Timing - I <sup>2</sup> C .....	22
Figure 5. Analog Input Signal Flow .....	26
Figure 6. Single-Ended MIC Configuration .....	27
Figure 7. Differential MIC Configuration .....	27
Figure 8. ALC .....	28
Figure 9. Noise Gate Attenuation .....	28
Figure 10. DSP Engine Signal Flow .....	29
Figure 11. PWM Output Stage .....	30
Figure 12. Analog Output Stage .....	30
Figure 13. Beep Configuration Options .....	31
Figure 14. Peak Detect & Limiter .....	32
Figure 15. Battery Compensation .....	34
Figure 16. I <sup>2</sup> S Format .....	36
Figure 17. Left-Justified Format .....	36
Figure 18. Right-Justified Format (DAC only) .....	36
Figure 19. DSP Mode Format) .....	36
Figure 20. Control Port Timing, I <sup>2</sup> C Write .....	38
Figure 21. Control Port Timing, I <sup>2</sup> C Read .....	38
Figure 22. THD+N vs. Output Power per Channel at 1.8 V (16 Ω load) .....	75
Figure 23. THD+N vs. Output Power per Channel at 2.5 V (16 Ω load) .....	75
Figure 24. THD+N vs. Output Power per Channel at 1.8 V (32 Ω load) .....	76
Figure 25. THD+N vs. Output Power per Channel at 2.5 V (32 Ω load) .....	76
Figure 26. ADC Passband Ripple .....	79
Figure 27. ADC Stopband Rejection .....	79
Figure 28. ADC Transition Band .....	79
Figure 29. ADC Transition Band Detail .....	79
Figure 30. DAC Passband Ripple .....	79
Figure 31. DAC Stopband .....	79
Figure 32. DAC Transition Band .....	79
Figure 33. DAC Transition Band (Detail) .....	79

# 1. PIN DESCRIPTIONS

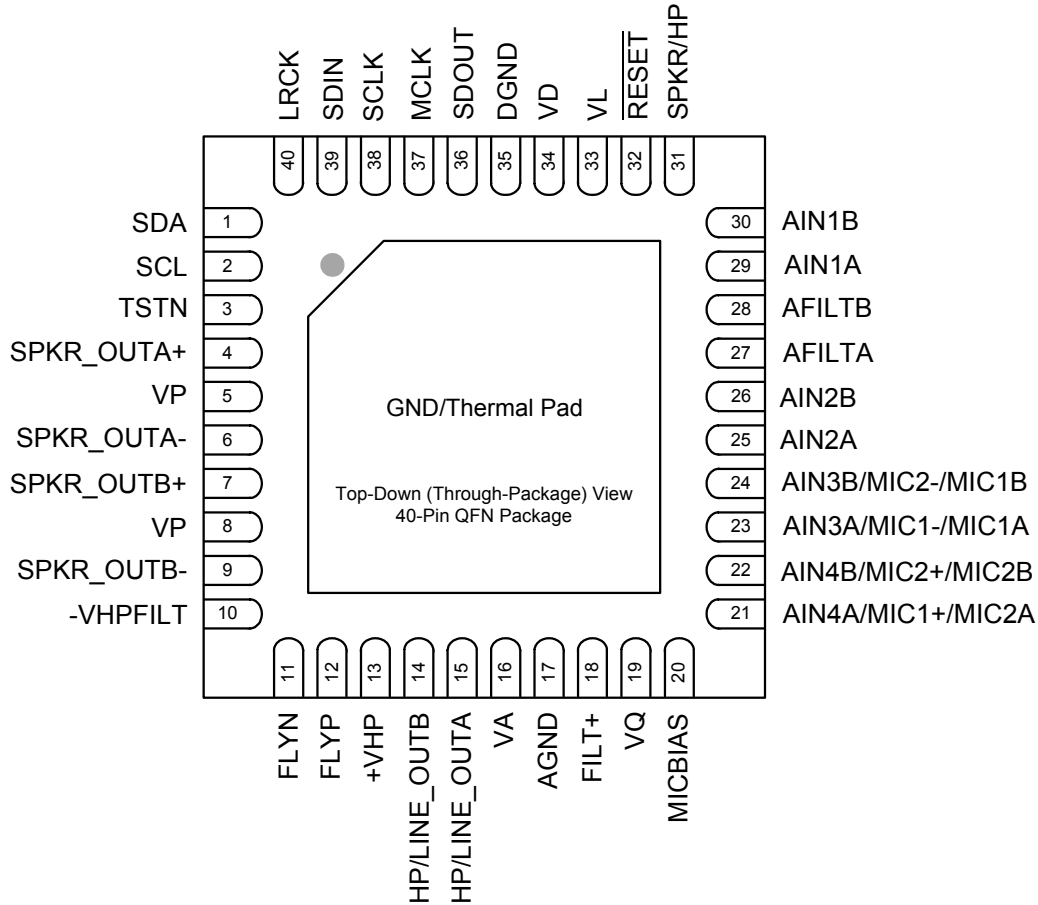

Pin Name	#	Pin Description
SDA	1	<b>Serial Control Data (Input/Output)</b> - SDA is a data I/O in I <sup>2</sup> C Mode.
SCL	2	<b>Serial Control Port Clock (Input)</b> - Serial clock for the serial control port.
TSTN	3	<b>Test In</b> - This pin is an input used for test purposes only. It must be tied to ground for normal operation.
SPKR_OUTA+	4	<b>PWM Speaker Output (Output)</b> - Full-bridge amplified PWM speaker outputs.
SPKR_OUTA-	6	
SPKR_OUTB+	7	
SPKR_OUTB-	9	
VP	5 8	<b>Power for PWM Drivers (Input)</b> - Power supply for the PWM output driver stages.
-VHPFILT	10	<b>Inverting Charge Pump Filter Connection (Output)</b> - Power supply from the inverting charge pump that provides the negative rail for the headphone/line amplifiers.
FLYN	11	<b>Charge Pump Cap Negative Node (Output)</b> - Negative node for the inverting charge pump's flying capacitor.
FLYP	12	<b>Charge Pump Cap Positive Node (Output)</b> - Positive node for the inverting charge pump's flying capacitor.
+VHP	13	<b>Positive Analog Power for Headphone (Input)</b> - Positive voltage rail and power for the internal headphone amplifiers and inverting charge pump.
HP/LINE_OUTB, A	14,15	<b>Headphone/Line Audio Output (Output)</b> - Stereo headphone or line level analog outputs.



VA	16	<b>Analog Power (Input)</b> - Positive power for the internal analog section.
AGND	17	<b>Analog Ground (Input)</b> - Ground reference for the internal analog section.
FILT+	18	<b>Positive Voltage Reference (Output)</b> - Positive reference voltage for the internal sampling circuits.
VQ	19	<b>Quiescent Voltage (Output)</b> - Filter connection for the internal quiescent voltage.
MICBIAS	20	<b>Microphone Bias (Output)</b> - Low noise bias supply for an external microphone. Electrical characteristics are specified in the DC Electrical Characteristics table.
AIN4A,B AIN3A,B	21,22 23,24	<b>Line-Level Analog Inputs (Input)</b> - Single-ended stereo line-level analog inputs.
MIC1+,- MIC2+,-	21,23 22,24	<b>Differential Microphone Inputs (Input)</b> - Differential stereo microphone inputs.
MIC2A,B MIC1A,B	21,22 23,24	<b>Single-Ended Microphone Inputs (Input)</b> - Single-ended stereo microphone inputs.
AIN2A,B AIN1A,B	25,26 29,30	<b>Line-Level Analog Inputs (Input)</b> - Single-ended stereo line-level analog inputs.
AFILTA,B	27,28	<b>Anti-alias Filter Connection (Output)</b> - Anti-alias filter connection for the ADC inputs.
SPKR/HP	31	<b>Speaker/Headphone Switch (Input)</b> - Powers down the left and/or right channel of the speaker and/or headphone outputs.
RESET	32	<b>Reset (Input)</b> - The device enters a low power mode when this pin is driven low.
VL	33	<b>Digital Interface Power (Input)</b> - Determines the required signal level for the serial audio interface and host control port.
VD	34	<b>Digital Power (Input)</b> - Positive power for the internal digital section.
DGND	35	<b>Digital Ground (Input)</b> - Ground reference for the internal digital section.
SDOUT	36	<b>Serial Audio Data Output (Output)</b> - Output for two's complement serial audio data.
MCLK	37	<b>Master Clock (Input)</b> - Clock source for the delta-sigma modulators.
SCLK	38	<b>Serial Clock (Input/Output)</b> - Serial clock for the serial audio interface.
SDIN	39	<b>Serial Audio Data Input (Input)</b> - Input for two's complement serial audio data.
LRCK	40	<b>Left Right Clock (Input/Output)</b> - Determines which channel, Left or Right, is currently active on the serial audio data line.
GND/Thermal Pad	-	Ground reference for PWM power FETs and charge pump; thermal relief pad for optimized heat dissipation.

## 1.1 I/O Pin Characteristics

Input and output levels and associated power supply voltage are shown in the table below. Logic levels should not exceed the corresponding power supply voltage.

Power Supply	Pin Name	I/O	Driver	Receiver
VL	RESET	Input	-	1.65 V - 3.47 V, with Hysteresis
	SCL	Input	-	1.65 V - 3.47 V, with Hysteresis
	SDA	Input/Output	1.65 V - 3.47 V, CMOS/Open Drain	1.65 V - 3.47 V, with Hysteresis
	MCLK	Input	-	1.65 V - 3.47 V
	LRCK	Input/Output	1.65 V - 3.47 V, CMOS	1.65 V - 3.47 V
	SCLK	Input/Output	1.65 V - 3.47 V, CMOS	1.65 V - 3.47 V
	SDOUT	Output	1.65 V - 3.47 V V, CMOS	
VA	SDIN	Input	-	1.65 V - 3.47 V
	SPKR/HP	Input	-	1.65 V - 2.63 V
VP	SPKR_OUTA+	Output	1.6 V - 5.25 V Power MOSFET	-
	SPKR_OUTA-	Output	1.6 V - 5.25 V Power MOSFET	-
	SPKR_OUTB+	Output	1.6 V - 5.25 V Power MOSFET	-
	SPKR_OUTB-	Output	1.6 V - 5.25 V Power MOSFET	-

## 2. TYPICAL CONNECTION DIAGRAM

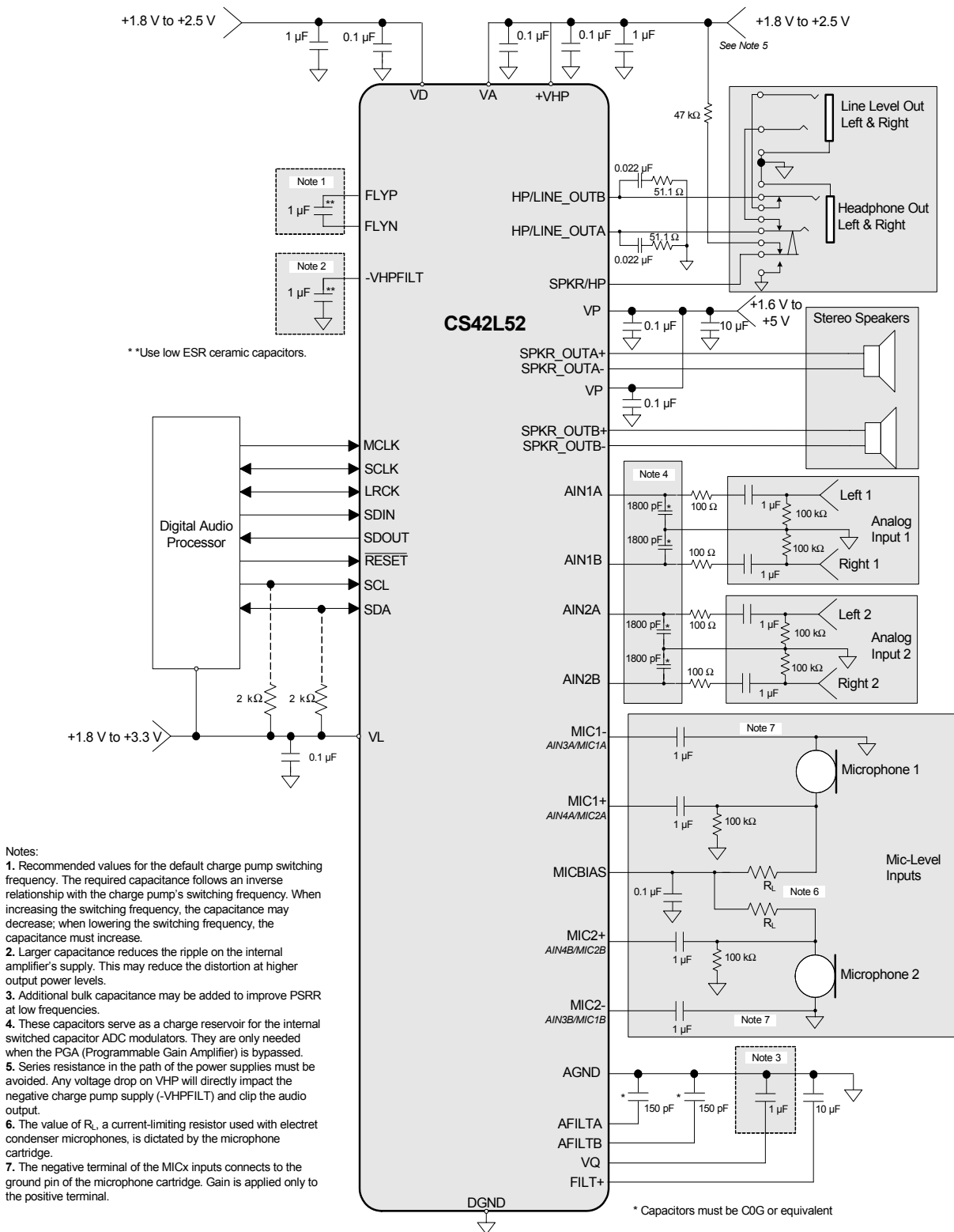

**Figure 1. Typical Connection Diagram**

### 3. CHARACTERISTIC AND SPECIFICATIONS

#### RECOMMENDED OPERATING CONDITIONS

(AGND=DGND=0 V, all voltages with respect to ground.)

Parameters	Symbol	Min	Max	Units	
DC Power Supply					
Analog	VA	1.65	2.63	V	
Headphone Amplifier	+VHP	1.65	2.63	V	
Speaker Amplifier	VP	1.60	5.25	V	
Digital	VD	1.65	2.63	V	
Serial/Control Port Interface	VL	1.65	3.47	V	
Ambient Temperature	T <sub>A</sub>	Commercial - CNZ	-40	+85	°C
		Automotive - DNZ	-40	+105	°C

#### ABSOLUTE MAXIMUM RATINGS

(AGND = DGND = 0 V; all voltages with respect to ground.)

Parameters	Symbol	Min	Max	Units	
DC Power Supply	Analog	VA, VHP	-0.3	3.0	V
	Speaker	VP	-0.3	5.5	V
	Digital	VD	-0.3	3.0	V
	Serial/Control Port Interface	VL	-0.3	4.0	V
Input Current	(Note 1)	I <sub>in</sub>	-	±10	mA
Analog Input Voltage	(Note 2)	V <sub>IN</sub>	AGND-0.7	VA+0.7	V
Digital Input Voltage	(Note 2)	V <sub>IND</sub>	-0.3	VL+ 0.4	V
Ambient Operating Temperature (power applied)	T <sub>A</sub>	-50	+115	°C	
Storage Temperature	T <sub>stg</sub>	-65	+150	°C	

**WARNING:** Operation at or beyond these limits may result in permanent damage to the device. Normal operation is not guaranteed at these extremes.

#### Notes:

1. Any pin except supplies. Transient currents of up to ±100 mA on the analog input pins will not cause SCR latch-up.
2. The maximum over/under voltage is limited by the input current.

## ANALOG INPUT CHARACTERISTICS (COMMERCIAL - CNZ)

(Test Conditions (unless otherwise specified): Input sine wave (relative to digital full-scale): 1 kHz through passive input filter;  $V_L = V_D = V_{HP} = 1.8\text{ V}$ ;  $T_A = +25^\circ\text{C}$ ; Measurement Bandwidth is 10 Hz to 20 kHz unless otherwise specified. Sample Frequency = 48 kHz)

Parameters		VA = 2.5V			VA = 1.8V			Unit	
		Min	Typ	Max	Min	Typ	Max		
<b>Analog In to ADC (PGA bypassed)</b>									
Dynamic Range	A-weighted	93	99	-	90	96	-	dB	
	unweighted	90	96	-	87	93	-	dB	
Total Harmonic Distortion + Noise	-1 dBFS	-	-86	-80	-	-84	-78	dB	
	-20 dBFS	-	-76	-	-	-73	-	dB	
	-60 dBFS	-	-36	-30	-	-33	-27	dB	
<b>Analog In to PGA to ADC</b>									
Dynamic Range									
PGA Setting: 0 dB	A-weighted	92	98	-	89	95	-	dB	
	unweighted	89	95	-	86	92	-	dB	
PGA Setting: +12 dB	A-weighted	85	91	-	82	88	-	dB	
	unweighted	82	88	-	79	85	-	dB	
Total Harmonic Distortion + Noise									
PGA Setting: 0 dB	-1 dBFS	-	-88	-82	-	-86	-80	dB	
	-60 dBFS	-	-35	-29	-	-32	-26	dB	
PGA Setting: +12 dB	-1 dBFS	-	-85	-79	-	-83	-77	dB	
<b>Analog In to MIC Pre-Amp (+16 dB) to PGA to ADC</b>									
Dynamic Range									
PGA Setting: 0 dB	A-weighted	-	86	-	-	83	-	dB	
	unweighted	-	83	-	-	80	-	dB	
Total Harmonic Distortion + Noise									
PGA Setting: 0 dB	-1 dBFS	-	-76	-	-	-74	-	dB	
<b>Analog In to MIC Pre-Amp (+32 dB) to PGA to ADC</b>									
Dynamic Range									
PGA Setting: 0 dB	A-weighted	-	78	-	-	75	-	dB	
	unweighted	-	74	-	-	71	-	dB	
Total Harmonic Distortion + Noise									
PGA Setting: 0 dB	-2 dBFS	-	-74	-	-	-71	-	dB	
<b>Other Characteristics</b>									
DC Accuracy									
Interchannel Gain Mismatch		-	0.2	-	-	0.2	-	dB	
Gain Drift		-	±100	-	-	±100	-	ppm/°C	
Offset Error SDOUT Code with HPF On		-	352	-	-	352	-	LSB	
Input									
Interchannel Isolation		-	90	-	-	90	-	dB	
HP Amp to Analog Input Isolation (Note 3)	$R_L = 10\text{ k}\Omega$	-	100	-	-	100	-	dB	
	$R_L = 16\ \Omega$	-	70	-	-	70	-	dB	
Speaker Amp to Analog Input Isolation		-	60	-	-	60	-	dB	
Full-scale Input Voltage		ADC	$0.73 \cdot V_A$	$0.769 \cdot V_A$	$0.83 \cdot V_A$	$0.73 \cdot V_A$	$0.769 \cdot V_A$	$0.83 \cdot V_A$	$V_{pp}$
		PGA (0 dB)	$0.73 \cdot V_A$	$0.770 \cdot V_A$	$0.83 \cdot V_A$	$0.73 \cdot V_A$	$0.770 \cdot V_A$	$0.83 \cdot V_A$	$V_{pp}$
		PGA (+12 dB)		$0.194 \cdot V_A$			$0.194 \cdot V_A$		$V_{pp}$
		MIC (+16 dB)		$0.115 \cdot V_A$			$0.115 \cdot V_A$		$V_{pp}$
		MIC (+32 dB)		$0.019 \cdot V_A$			$0.019 \cdot V_A$		$V_{pp}$
Input Impedance (Note 4)		ADC	-	20	-	-	20	-	$\text{k}\Omega$
		PGA	-	39	-	-	39	-	$\text{k}\Omega$
		MIC	-	50	-	-	50	-	$\text{k}\Omega$

3. Measured with DAC delivering full-scale output into specified load.

4. Measured between analog input and AGND.

## ANALOG INPUT CHARACTERISTICS (AUTOMOTIVE - DNZ)

(Test Conditions (unless otherwise specified): Input sine wave (relative to full-scale): 1 kHz through passive input filter;  $V_L = V_D = V_{HP} = 1.8\text{ V}$ ;  $T_A = -40\text{ to }+85^\circ\text{C}$ ; Measurement Bandwidth is 10 Hz to 20 kHz unless otherwise specified. Sample Frequency = 48 kHz)

Parameters		VA = 2.37 - 2.63 V			VA = 1.65 - 1.89 V			Unit
		Min	Typ	Max	Min	Typ	Max	
<b>Analog In to ADC</b>								
Dynamic Range	A-weighted	91	99	-	88	96	-	dB
	unweighted	88	96	-	85	93	-	dB
Total Harmonic Distortion + Noise	-1 dBFS	-	-86	-78	-	-84	-76	dB
	-20 dBFS	-	-76	-	-	-73	-	dB
	-60 dBFS	-	-36	-28	-	-33	-25	dB
<b>Analog In to PGA to ADC</b>								
Dynamic Range PGA Setting: 0 dB	A-weighted	90	98	-	87	95	-	dB
	unweighted	87	95	-	84	92	-	dB
Dynamic Range PGA Setting: +12 dB	A-weighted	83	91	-	80	88	-	dB
	unweighted	80	88	-	77	85	-	dB
Total Harmonic Distortion + Noise PGA Setting: 0 dB	-1 dBFS	-	-88	-80	-	-86	-78	dB
	-60 dBFS	-	-35	-27	-	-32	-24	dB
	-1 dBFS PGA Setting: +12 dB	-	-85	-77	-	-83	-75	dB
<b>Analog In to MIC Pre-Amp (+16 dB) to PGA to ADC</b>								
Dynamic Range PGA Setting: 0 dB	A-weighted	-	86	-	-	83	-	dB
	unweighted	-	83	-	-	80	-	dB
Total Harmonic Distortion + Noise PGA Setting: 0 dB	-1 dBFS	-	-76	-	-	-74	-	dB
<b>Analog In to MIC Pre-Amp (+32 dB) to PGA to ADC</b>								
Dynamic Range PGA Setting: 0 dB	A-weighted	-	78	-	-	75	-	dB
	unweighted	-	74	-	-	71	-	dB
Total Harmonic Distortion + Noise PGA Setting: 0 dB	-2 dBFS	-	-74	-	-	-71	-	dB
<b>Other Characteristics</b>								
DC Accuracy								
Interchannel Gain Mismatch		-	0.1	-	-	0.1	-	dB
Gain Drift		-	±100	-	-	±100	-	ppm/°C
Offset Error SDOUT Code with HPF On		-	352	-	-	352	-	LSB
Input								
Interchannel Isolation		-	90	-	-	90	-	dB
HP Amp to Analog Input Isolation (Note 3)	$R_L = 10\text{ k}\Omega$	-	100	-	-	100	-	dB
	$R_L = 16\text{ }\Omega$	-	70	-	-	70	-	dB
Speaker Amp to Analog Input Isolation		-	60	-	-	60	-	dB
Full-scale Input Voltage	ADC	$0.73 \cdot V_A$	$0.769 \cdot V_A$	$0.83 \cdot V_A$	$0.73 \cdot V_A$	$0.769 \cdot V_A$	$0.83 \cdot V_A$	$V_{pp}$
	PGA (0 dB)	$0.73 \cdot V_A$	$0.770 \cdot V_A$	$0.83 \cdot V_A$	$0.73 \cdot V_A$	$0.770 \cdot V_A$	$0.83 \cdot V_A$	$V_{pp}$
	PGA (+12 dB)		$0.194 \cdot V_A$			$0.194 \cdot V_A$		$V_{pp}$
	MIC (+16 dB)		$0.115 \cdot V_A$			$0.115 \cdot V_A$		$V_{pp}$
	MIC (+32 dB)		$0.019 \cdot V_A$			$0.019 \cdot V_A$		$V_{pp}$
Input Impedance (Note 4)	ADC	18	-	-	18	-	-	$\text{k}\Omega$
	PGA	40	-	-	40	-	-	$\text{k}\Omega$
	MIC	50	-	-	50	-	-	$\text{k}\Omega$

---

**ADC DIGITAL FILTER CHARACTERISTICS**

Parameters (Note 5)		Min	Typ	Max	Unit
Passband (Frequency Response)	to -0.1 dB corner	0	-	0.4948	Fs
Passband Ripple		-0.09	-	0.17	dB
Stopband		0.6	-	-	Fs
Stopband Attenuation		33	-	-	dB
Total Group Delay		-	7.6/Fs	-	s
<b>High-Pass Filter Characteristics (48 kHz Fs)</b>					
Frequency Response	-3.0 dB	-	3.6	-	Hz
	-0.13 dB	-	24.2	-	Hz
Phase Deviation	@ 20 Hz	-	10	-	Deg
Passband Ripple		-	-	0.17	dB
Filter Settling Time		-	10 <sup>5</sup> /Fs	0	s

5. Response is clock-dependent and will scale with Fs. Note that the response plots ([Figures 26 to 29 on page 79](#)) have been normalized to Fs and can be de-normalized by multiplying the X-axis scale by Fs. HPF parameters are for Fs = 48 kHz.



## ANALOG OUTPUT CHARACTERISTICS (COMMERCIAL - CNZ)

(Test conditions (unless otherwise specified): Input test signal is a full-scale 997 Hz sine wave;  $V_L = V_D = V_{HP} = 1.8\text{ V}$ ;  $T_A = +25^\circ\text{C}$ ; Measurement bandwidth is 10 Hz to 20 kHz; Sample Frequency = 48 kHz; test load  $R_L = 10\text{ k}\Omega$ ,  $C_L = 10\text{ pF}$  for the line output (see [Figure 2](#)), and test load  $R_L = 16\ \Omega$ ,  $C_L = 10\text{ pF}$  (see [Figure 2](#)) for the headphone output.  $HP\_GAIN[2:0] = 011$ .)

Parameters (Note 6)		VA = 2.5 V			VA = 1.8 V			Unit
		Min	Typ	Max	Min	Typ	Max	
<b><math>R_L = 10\text{ k}\Omega</math></b>								
<b>Dynamic Range</b>								
18 to 24-Bit	A-weighted	92	98	-	89	95	-	dB
	unweighted	89	95	-	86	92	-	dB
16-Bit	A-weighted	-	96	-	-	93	-	dB
	unweighted	-	93	-	-	90	-	dB
<b>Total Harmonic Distortion + Noise</b>								
18 to 24-Bit	0 dB	-	-86	-80	-	-88	-82	dB
	-20 dB	-	-75	-	-	-72	-	dB
	-60 dB	-	-35	-29	-	-32	-26	dB
16-Bit	0 dB	-	-86	-	-	-88	-	dB
	-20 dB	-	-73	-	-	-70	-	dB
	-60 dB	-	-33	-	-	-30	-	dB
<b><math>R_L = 16\ \Omega</math></b>								
<b>Dynamic Range</b>								
18 to 24-Bit	A-weighted	92	98	-	89	95	-	dB
	unweighted	89	95	-	86	92	-	dB
16-Bit	A-weighted	-	96	-	-	93	-	dB
	unweighted	-	93	-	-	90	-	dB
<b>Total Harmonic Distortion + Noise</b>								
18 to 24-Bit	0 dB	-	-75	-69	-	-75	-69	dB
	-20 dB	-	-75	-	-	-72	-	dB
	-60 dB	-	-35	-29	-	-32	-26	dB
16-Bit	0 dB	-	-75	-	-	-75	-	dB
	-20 dB	-	-73	-	-	-70	-	dB
	-60 dB	-	-33	-	-	-30	-	dB
<b>Other Characteristics for <math>R_L = 16\ \Omega</math> or <math>10\text{ k}\Omega</math></b>								
Output Parameters (Note 7)	Modulation Index (MI) Analog Gain Multiplier (G)	-	0.6787 0.6047	-	-	0.6787 0.6047	-	
Full-scale Output Voltage ( $2 \cdot G \cdot MI \cdot VA$ ) (Note 7)		Refer to Table "Line Output Voltage Level Characteristics" on page 18						Vpp
Full-scale Output Power (Note 7)		Refer to Table "Headphone Output Power Characteristics" on page 19						
Interchannel Isolation (1 kHz)	16 $\Omega$	-	80	-	-	80	-	dB
	10 k $\Omega$	-	95	-	-	93	-	dB
Speaker Amp to HP Amp Isolation		-	80	-	-	80	-	dB
Interchannel Gain Mismatch		-	0.1	0.25	-	0.1	0.25	dB
Gain Drift		-	$\pm 100$	-	-	$\pm 100$	-	ppm/ $^\circ\text{C}$
AC-Load Resistance ( $R_L$ ) (Note 8)		16	-	-	16	-	-	$\Omega$
Load Capacitance ( $C_L$ ) (Note 8)		-	-	150	-	-	150	pF

6. One-half LSB of triangular PDF dither is added to data.
7. Full-scale output voltage and power is determined by the gain setting, G, in register "Headphone Analog Gain" on page 51. High gain settings at certain VA and VHP supply levels may cause clipping when the audio signal approaches full-scale, maximum power output, as shown in [Figures 22 - 25 on page 76](#).

## ANALOG OUTPUT CHARACTERISTICS (AUTOMOTIVE - DNZ)

(Test conditions (unless otherwise specified): Input test signal is a full-scale 997 Hz sine wave;  $V_L = V_D = V_{HP} = 1.8$  V;  $T_A = -40$  to  $+85^\circ\text{C}$ ; Measurement bandwidth is 10 Hz to 20 kHz; Sample Frequency = 48 kHz and 96 kHz; test load  $R_L = 10$  k $\Omega$ ,  $C_L = 10$  pF for the line output (see [Figure 2](#)), and test load  $R_L = 16$   $\Omega$ ,  $C_L = 10$  pF (see [Figure 2](#)) for the headphone output. HPGAIN[2:0] = 011.)

Parameters (Note 6)		VA = 2.37 - 2.5 V			VA = 1.65 - 1.89 V			Unit
		Min	Typ	Max	Min	Typ	Max	
<b><math>R_L = 10</math> k<math>\Omega</math></b>								
<b>Dynamic Range</b>								
18 to 24-Bit	A-weighted	90	98	-	87	95	-	dB
	unweighted	87	95	-	84	92	-	dB
16-Bit	A-weighted	-	96	-	-	93	-	dB
	unweighted	-	93	-	-	90	-	dB
<b>Total Harmonic Distortion + Noise</b>								
18 to 24-Bit	0 dB	-	-86	-78	-	-88	-80	dB
	-20 dB	-	-75	-	-	-72	-	dB
	-60 dB	-	-35	-27	-	-32	-24	dB
16-Bit	0 dB	-	-86	-	-	-88	-	dB
	-20 dB	-	-73	-	-	-70	-	dB
	-60 dB	-	-33	-	-	-30	-	dB
<b><math>R_L = 16</math> <math>\Omega</math></b>								
<b>Dynamic Range</b>								
18 to 24-Bit	A-weighted	90	98	-	87	95	-	dB
	unweighted	87	95	-	84	92	-	dB
16-Bit	A-weighted	-	96	-	-	93	-	dB
	unweighted	-	93	-	-	90	-	dB
<b>Total Harmonic Distortion + Noise</b>								
18 to 24-Bit	0 dB	-	-75	-67	-	-75	-67	dB
	-20 dB	-	-75	-	-	-72	-	dB
	-60 dB	-	-35	-27	-	-32	-24	dB
16-Bit	0 dB	-	-75	-	-	-75	-	dB
	-20 dB	-	-73	-	-	-70	-	dB
	-60 dB	-	-33	-	-	-30	-	dB
<b>Other Characteristics for <math>R_L = 16</math> <math>\Omega</math> or 10 k<math>\Omega</math></b>								
Output Parameters (Note 7)	Modulation Index (MI) Analog Gain Multiplier (G)	-	0.6787 0.6047	-	-	0.6787 0.6047	-	
Full-scale Output Voltage ( $2 \cdot G \cdot MI \cdot VA$ )	(Note 7)	Refer to the table in "Line Output Voltage Level Characteristics" on page 18						Vpp
Full-scale Output Power	(Note 7)	Refer to the table in "Headphone Output Power Characteristics" on page 19						
Interchannel Isolation (1 kHz)	16 $\Omega$	-	80	-	-	80	-	dB
	10 k $\Omega$	-	95	-	-	93	-	dB
Speaker Amp to HP Amp Isolation		-	80	-	-	80	-	dB
Interchannel Gain Mismatch		-	0.1	0.25	-	0.1	0.25	dB
Gain Drift		-	$\pm 100$	-	-	$\pm 100$	-	ppm/ $^\circ\text{C}$
AC-Load Resistance ( $R_L$ )	(Note 8)	16	-	-	16	-	-	$\Omega$
Load Capacitance ( $C_L$ )	(Note 8)	-	-	150	-	-	150	pF

8. See [Figure 2](#).  $R_L$  and  $C_L$  reflect the recommended minimum resistance and maximum capacitance required for the internal op-amp's stability and signal integrity. In this circuit topology,  $C_L$  will effectively move the band-limiting pole of the amp in the output stage. Increasing this value beyond the recommended 150 pF can cause the internal op-amp to become unstable.

## ANALOG PASSTHRU CHARACTERISTICS

(Test Conditions (unless otherwise specified): Input sine wave (relative to full-scale): 1 kHz through passive input filter;  $V_L = V_D = V_{HP} = 1.8\text{ V}$ ;  $T_A = +25^\circ\text{C}$ ; Measurement Bandwidth is 10 Hz to 20 kHz unless otherwise specified. Sample Frequency = 48 kHz)

Parameters	VA = 2.5 V			VA = 1.8 V			Unit
	Min	Typ	Max	Min	Typ	Max	
<b>Analog In to HP/Line Amp</b>							
Dynamic Range	A-weighted	-	96	-	94	-	dB
	unweighted	-	93	-	91	-	dB
Total Harmonic Distortion + Noise	-1 dBFS	-	-80	-	-80	-	dB
	-20 dBFS	-	-73	-	-71	-	dB
	-60 dBFS	-	-33	-	-31	-	dB
Passband Ripple		0/-0.3		0/-0.3			dB

## PWM OUTPUT CHARACTERISTICS (Note 9)

(Test conditions (unless otherwise specified): Input test signal is a full scale 997 Hz signal; measurement bandwidth is 10 Hz to 20 kHz; MCLK = 12.2880 MHz, Sample Frequency = 48 kHz; test load  $R_L = 8\ \Omega$  for stereo full-bridge,  $R_L = 4\ \Omega$  for mono parallel full-bridge;  $V_D = V_L = V_A = V_{HP} = 1.8\text{V}$ ; PWM Modulation Index of 0.85, PWM Switch Rate = 384 kHz)

Parameters <small>(Note 10)</small>	Symbol	Conditions	Min	Typ	Max	Units
<b>VP = 5.0 V</b>						
<b>Power Output per Channel</b>						
Stereo Full-Bridge	$P_O$	THD+N < 10%	-	1.00	-	$W_{rms}$
		THD+N < 1%	-	0.80	-	$W_{rms}$
Mono Parallel Full-Bridge	$P_O$	THD+N < 10%	-	1.90	-	$W_{rms}$
		THD+N < 1%	-	1.50	-	$W_{rms}$
<b>Total Harmonic Distortion + Noise</b>						
Stereo Full-Bridge	THD+N	$P_O = 0\text{ dBFS} = 0.8\text{W}$	-	0.52	-	%
		$P_O = -3\text{ dBFS} = 0.75\text{ W}$	-	0.10	-	%
Mono Parallel Full-Bridge		$P_O = 0\text{ dBFS} = 1.5\text{ W}$	-	0.50	-	%
<b>Dynamic Range</b>						
Stereo Full-Bridge	DR	$P_O = -60\text{ dBFS}$ , A-Weighted	-	91	-	dB
		$P_O = -60\text{ dBFS}$ , Unweighted	-	88	-	dB
Mono Parallel Full-Bridge		$P_O = -60\text{ dBFS}$ , A-Weighted	-	91	-	dB
		$P_O = -60\text{ dBFS}$ , Unweighted	-	88	-	dB
<b>VP = 3.7 V</b>						
<b>Power Output per Channel</b>						
Stereo Full-Bridge	$P_O$	THD+N < 10%	-	0.55	-	$W_{rms}$
		THD+N < 1%	-	0.45	-	$W_{rms}$
Mono Parallel Full-Bridge	$P_O$	THD+N < 10%	-	1.00	-	$W_{rms}$
		THD+N < 1%	-	0.84	-	$W_{rms}$
<b>Total Harmonic Distortion + Noise</b>						
Stereo Full-Bridge	THD+N	$P_O = 0\text{ dBFS} = 0.43\text{ W}$	-	0.54	-	%
		$P_O = -3\text{ dBFS} = 0.41\text{ W}$	-	0.09	-	%
Mono Parallel Full-Bridge		$P_O = 0\text{ dBFS} = 0.81\text{ W}$	-	0.45	-	%
<b>Dynamic Range</b>						
Stereo Full-Bridge	DR	$P_O = -60\text{ dBFS}$ , A-Weighted	-	91	-	dB
		$P_O = -60\text{ dBFS}$ , Unweighted	-	88	-	dB
Mono Parallel Full-Bridge		$P_O = -60\text{ dBFS}$ , A-Weighted	-	95	-	dB
		$P_O = -60\text{ dBFS}$ , Unweighted	-	92	-	dB

Parameters (Note 10)	Symbol	Conditions	Min	Typ	Max	Units
<b>VP = 2.5 V</b>						
<b>Power Output per Channel</b>	PO					
Stereo Full-Bridge		THD+N < 10%	-	0.23	-	W <sub>rms</sub>
		THD+N < 1%	-	0.19	-	W <sub>rms</sub>
Mono Parallel Full-Bridge		THD+N < 10%	-	0.44	-	W <sub>rms</sub>
		THD+N < 1%	-	0.35	-	W <sub>rms</sub>
<b>Total Harmonic Distortion + Noise</b>	THD+N					
Stereo Full-Bridge		PO = 0 dBFS = 0.18 W	-	0.50	-	%
Mono Parallel Full-Bridge		PO = -3 dBFS = 0.17 W	-	0.08	-	%
		PO = 0 dBFS = 0.35 W	-	0.43	-	%
<b>Dynamic Range</b>	DR					
Stereo Full-Bridge		PO = -60 dBFS, A-Weighted	-	91	-	dB
		PO = -60 dBFS, Unweighted	-	88	-	dB
Mono Parallel Full-Bridge		PO = -60 dBFS, A-Weighted	-	94	-	dB
		PO = -60 dBFS, Unweighted	-	91	-	dB
MOSFET On Resistance	R <sub>DS(ON)</sub>	VP = 5.0V, Id = 0.5 A	-	600	-	mΩ
MOSFET On Resistance	R <sub>DS(ON)</sub>	VP = 3.7V, Id = 0.5 A	-	640	-	mΩ
MOSFET On Resistance	R <sub>DS(ON)</sub>	VP = 2.5V, Id = 0.5 A	-	760	-	mΩ
Efficiency	η	VP = 5.0 V, PO = 2 x 0.8 W, RL = 8 Ω	-	82	-	%
Output Operating Peak Current	IPC		-	-	1.5	A

9. The PWM driver should be used in captive speaker systems only.

10. Optimal PWM performance is achieved when MCLK > 12 MHz.

## LINE OUTPUT VOLTAGE LEVEL CHARACTERISTICS

Test conditions (unless otherwise specified): Input test signal is a full-scale 997 Hz sine wave; measurement bandwidth is 10 Hz to 20 kHz; Sample Frequency = 48 kHz; test load RL = 10 kΩ, CL = 10 pF (see Figure 2).

Parameters			VA = 2.5V			VA = 1.8V			Unit
			Min	Typ	Max	Min	Typ	Max	
<b>AOUTx Voltage Into RL = 10 kΩ</b>									
HP_GAIN[2:0]	Analog Gain (G)	VHP							
000	0.3959	1.8 V	-	1.34	-	-	0.97	-	V <sub>pp</sub>
		2.5 V	-	1.34	-	-	0.97	-	V <sub>pp</sub>
001	0.4571	1.8 V	-	1.55	-	-	1.12	-	V <sub>pp</sub>
		2.5 V	-	1.55	-	-	1.12	-	V <sub>pp</sub>
010	0.5111	1.8 V	-	1.73	-	-	1.25	-	V <sub>pp</sub>
		2.5 V	-	1.73	-	-	1.25	-	V <sub>pp</sub>
011 (default)	0.6047	1.8 V	-	2.05	-	1.41	1.48	1.55	V <sub>pp</sub>
		2.5 V	1.95	2.05	2.15	-	1.48	-	V <sub>pp</sub>
100	0.7099	1.8 V	-	2.41	-	-	1.73	-	V <sub>pp</sub>
		2.5 V	-	2.41	-	-	1.73	-	V <sub>pp</sub>
101	0.8399	1.8 V	-	2.85	-	-	2.05	-	V <sub>pp</sub>
		2.5 V	-	2.85	-	-	2.05	-	V <sub>pp</sub>
110	1.0000	1.8 V	-	3.39	-	-	2.44	-	V <sub>pp</sub>
		2.5 V	-	3.39	-	-	2.44	-	V <sub>pp</sub>
111	1.1430	1.8 V	(See (Note 11))			-	2.79	-	V <sub>pp</sub>
		2.5 V	-	3.88	-	-	2.79	-	V <sub>pp</sub>

## HEADPHONE OUTPUT POWER CHARACTERISTICS

Test conditions (unless otherwise specified): Input test signal is a full-scale 997 Hz sine wave; measurement bandwidth is 10 Hz to 20 kHz; Sample Frequency = 48 kHz; test load  $R_L = 16 \Omega$ ,  $C_L = 10 \text{ pF}$  (see Figure 2).

Parameters			VA = 2.5V			VA = 1.8V			Unit
			Min	Typ	Max	Min	Typ	Max	
<b>AOUTx Power Into <math>R_L = 16 \Omega</math></b>									
HP_GAIN[2:0]	Analog Gain (G)	VHP							
000	0.3959	1.8 V	-	14	-	-	7	-	$\text{mW}_{\text{rms}}$
		2.5 V	-	14	-	-	7	-	$\text{mW}_{\text{rms}}$
001	0.4571	1.8 V	-	19	-	-	10	-	$\text{mW}_{\text{rms}}$
		2.5 V	-	19	-	-	10	-	$\text{mW}_{\text{rms}}$
010	0.5111	1.8 V	-	23	-	-	12	-	$\text{mW}_{\text{rms}}$
		2.5 V	-	23	-	-	12	-	$\text{mW}_{\text{rms}}$
011 (default)	0.6047	1.8 V	(Note 11)			-	17	-	$\text{mW}_{\text{rms}}$
		2.5 V	-	32	-	-	17	-	$\text{mW}_{\text{rms}}$
100	0.7099	1.8 V	(Note 11)			-	23	-	$\text{mW}_{\text{rms}}$
		2.5 V	-	44	-	-	23	-	$\text{mW}_{\text{rms}}$
101	0.8399	1.8 V	(Note 7, 11) See Figures 22 and 23 on page 75			(Note 7) See Figure 22 on page 75		$\text{mW}_{\text{rms}}$	
		2.5 V				-	32	-	$\text{mW}_{\text{rms}}$
110	1.0000	1.8 V	(Note 7, 11) See Figures 22 and 23 on page 75					$\text{mW}_{\text{rms}}$	
		2.5 V						$\text{mW}_{\text{rms}}$	
111	1.1430	1.8 V	(Note 7, 11) See Figures 22 and 23 on page 75					$\text{mW}_{\text{rms}}$	
		2.5 V						$\text{mW}_{\text{rms}}$	

11. VHP settings lower than VA reduces the headroom of the headphone amplifier. As a result, the DAC may not achieve the full THD+N performance at full-scale output voltage and power.

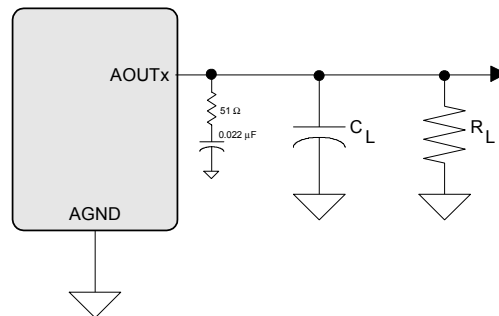

**Figure 2. Headphone Output Test Load**

---

**COMBINED DAC INTERPOLATION & ON-CHIP ANALOG FILTER RESPONSE**

---

Parameters (Note 12)	Min	Typ	Max	Unit	
Frequency Response 10 Hz to 20 kHz	-0.01	-	+0.08	dB	
Passband	to -0.05 dB corner	0	-	0.4780	Fs
	to -3 dB corner	0	-	0.4996	Fs
StopBand	0.5465	-	-	Fs	
StopBand Attenuation (Note 13)	50	-	-	dB	
Group Delay	-	9/Fs	-	s	
De-emphasis Error	Fs = 32 kHz	-	-	+1.5/+0	dB
	Fs = 44.1 kHz	-	-	+0.05/-0.25	dB
	Fs = 48 kHz	-	-	-0.2/-0.4	dB

12. Response is clock dependent and will scale with Fs. Note that the response plots (Figures 30 and 33 on page 79) have been normalized to Fs and can be de-normalized by multiplying the X-axis scale by Fs.

13. Measurement Bandwidth is from Stopband to 3 Fs.



## SWITCHING SPECIFICATIONS - SERIAL PORT

(Inputs: Logic 0 = DGND, Logic 1 = VL, SDOUT C<sub>LOAD</sub> = 15 pF.)

Parameters	Symbol	Min	Max	Units
RESET pin Low Pulse Width (Note 14)		1	-	ms
MCLK Frequency (Note 15)		(See "Serial Port Clocking" on page 34)		MHz
MCLK Duty Cycle		45	55	%
<b>Slave Mode</b>				
Input Sample Rate (LRCK)	F <sub>s</sub>	(See "Serial Port Clocking" on page 34)		kHz
LRCK Duty Cycle		45	55	%
SCLK Frequency	1/t <sub>p</sub>	-	64•F <sub>s</sub>	Hz
SCLK Duty Cycle		45	55	%
LRCK Setup Time Before SCLK Rising Edge	t <sub>s(LK-SK)</sub>	40	-	ns
LRCK Edge to SDOUT MSB Output Delay	t <sub>d(MSB)</sub>	-	52	ns
SDOUT Setup Time Before SCLK Rising Edge	t <sub>s(SDO-SK)</sub>	20	-	ns
SDOUT Hold Time After SCLK Rising Edge	t <sub>h(SK-SDO)</sub>	30	-	ns
SDIN Setup Time Before SCLK Rising Edge	t <sub>s(SD-SK)</sub>	20	-	ns
SDIN Hold Time After SCLK Rising Edge	t <sub>h</sub>	20	-	ns
<b>Master Mode</b>				
Output Sample Rate (LRCK) All Speed Modes	F <sub>s</sub>	(See "Serial Port Clocking" on page 34)		Hz
LRCK Duty Cycle		45	55	%
SCLK Frequency SCLK=MCLK mode	1/t <sub>p</sub>	-	12.0000	MHz
MCLK=12.0000 MHz	1/t <sub>p</sub>	-	68•F <sub>s</sub>	Hz
all other modes	1/t <sub>p</sub>	-	64•F <sub>s</sub>	Hz
SCLK Duty Cycle		45	55	%
LRCK Edge to SDOUT MSB Output Delay	t <sub>d(MSB)</sub>	-	52	ns
SDOUT Setup Time Before SCLK Rising Edge	t <sub>s(SDO-SK)</sub>	20	-	ns
SDOUT Hold Time After SCLK Rising Edge	t <sub>h(SK-SDO)</sub>	30	-	ns
SDIN Setup Time Before SCLK Rising Edge	t <sub>s(SD-SK)</sub>	20	-	ns
SDIN Hold Time After SCLK Rising Edge	t <sub>h</sub>	20	-	ns

14. After powering up the CS42L52, RESET should be held low after the power supplies and clocks are settled.

15. See "Example System Clock Frequencies" on page 77 for typical MCLK frequencies.

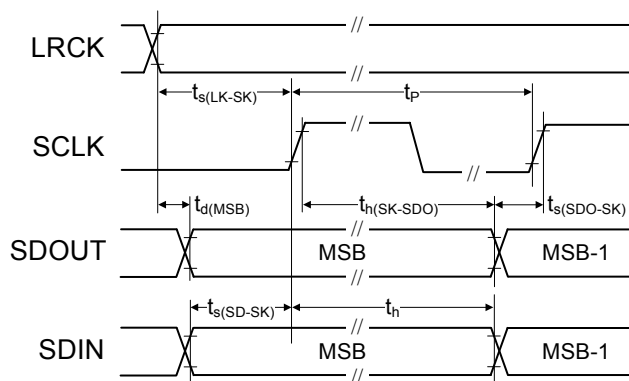

**Figure 3. Serial Audio Interface Timing**

## SWITCHING SPECIFICATIONS - I<sup>2</sup>C CONTROL PORT

(Inputs: Logic 0 = DGND, Logic 1 = VL, SDA C<sub>L</sub> = 30 pF)

Parameters	Symbol	Min	Max	Unit
SCL Clock Frequency	$f_{scl}$	-	100	kHz
RESET Rising Edge to Start	$t_{irs}$	500	-	ns
Bus Free Time Between Transmissions	$t_{buf}$	4.7	-	μs
Start Condition Hold Time (prior to first clock pulse)	$t_{hdst}$	4.0	-	μs
Clock Low time	$t_{low}$	4.7	-	μs
Clock High Time	$t_{high}$	4.0	-	μs
Setup Time for Repeated Start Condition	$t_{sust}$	4.7	-	μs
SDA Hold Time from SCL Falling	$t_{hdd}$	0	-	μs
SDA Setup time to SCL Rising	$t_{sud}$	250	-	ns
Rise Time of SCL and SDA	$t_{rc}$	-	1	μs
Fall Time SCL and SDA	$t_{fc}$	-	300	ns
Setup Time for Stop Condition	$t_{susp}$	4.7	-	μs
Acknowledge Delay from SCL Falling	$t_{ack}$	300	1000	ns

16. Data must be held for sufficient time to bridge the transition time,  $t_{fc}$ , of SCL.

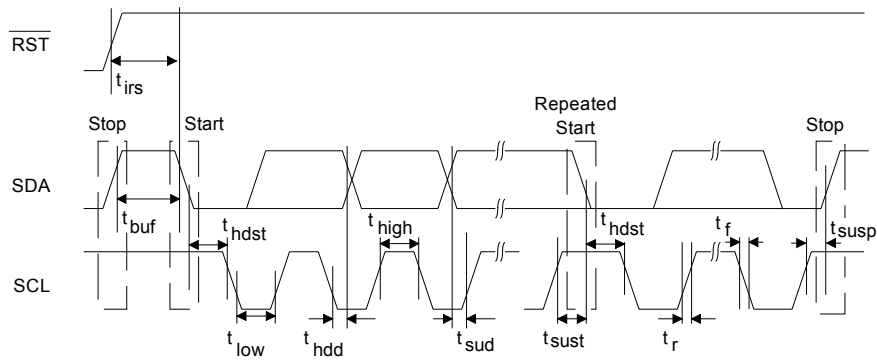

**Figure 4. Control Port Timing - I<sup>2</sup>C**

## DC ELECTRICAL CHARACTERISTICS

(AGND = 0 V; all voltages with respect to ground.)

Parameters	Min	Typ	Max	Units	
<b>VQ Characteristics</b>					
Nominal Voltage	-	0.5•VA	-	V	
Output Impedance	-	23	-	kΩ	
DC Current Source/Sink	-	-	1	μA	
<b>MIC BIAS Characteristics</b>					
Nominal Voltage	MICBIAS_LVL[1:0] = 00	-	0.8•VA	-	V
	MICBIAS_LVL[1:0] = 01	-	0.7•VA	-	V
	MICBIAS_LVL[1:0] = 10	-	0.6•VA	-	V
	MICBIAS_LVL[1:0] = 11	-	0.5•VA	-	V
DC Output Current	-	-	1	mA	
Power Supply Rejection Ratio (PSRR)	1 kHz	-	50	-	dB
<b>Power Supply Rejection Ratio Characteristics</b>					
PSRR @1 kHz (Note 17)	PGA to ADC	-	44	-	dB
	ADC	-	60	-	dB
	DAC (HP & Line Amps)	-	60	-	dB
PSRR @60 Hz (Note 17)	PGA to ADC (Note 18)	-	22	-	dB
	ADC	-	42	-	dB
	DAC (HP & Line Amps)	-	60	-	dB
PSRR @217 Hz	Full-Bridge PWM Outputs	-	56	-	dB

17. Valid with the recommended capacitor values on FILT+ and VQ. Increasing the capacitance will also increase the PSRR.

18. The PGA is biased with VQ, created from a resistor divider from the VA supply. Increasing the capacitance on VQ will also increase the PSRR at low frequencies. A 10 μF capacitor on VQ improves the PSRR to 42 dB.

## DIGITAL INTERFACE SPECIFICATIONS & CHARACTERISTICS

Parameters (Note 19)	Symbol	Min	Max	Units
Input Leakage Current	$I_{in}$	-	±10	μA
Input Capacitance		-	10	pF
<b>1.8 V - 3.3 V Logic</b>				
High-Level Output Voltage ( $I_{OH} = -100 \mu A$ )	$V_{OH}$	$V_L - 0.2$	-	V
Low-Level Output Voltage ( $I_{OL} = 100 \mu A$ )	$V_{OL}$	-	0.2	V
High-Level Input Voltage	$V_{IH}$	$0.83 \cdot V_L$ $0.76 \cdot V_L$ $0.68 \cdot V_L$ $0.65 \cdot V_L$	-	V
Low-Level Input Voltage	$V_{IL}$	-	$0.35 \cdot V_L$	V

19. See “I/O Pin Characteristics” on page 9 for serial and control port power rails.

**POWER CONSUMPTION** See (Note 20).

	Operation	Power Ctl. Registers										Typical Current (mA)					Total Power (mW <sub>rms</sub> )				
		02h		03h			04h					i <sub>VHP</sub>	i <sub>VA</sub>	i <sub>VD</sub>	i <sub>VL</sub> VL=3.3V (Note 23)	i <sub>VP</sub> VP=3.7V					
		PDN_PGAB	PDN_PGAA	PDN_ADCB	PDN_ADCA	PDN	PDN_MICB	PDN_MICA	PDN_MICBIAS	PDN_HPBI[1:0]	PDN_HPAA[1:0]							PDN_SPKB[1:0]	PDN_SPKA[1:0]	v	
1	Off (Note 21)	x	x	x	x	x	x	x	x	x	x	x	x	1.8	0.00	0.00	0.00	0.00	0.00	<b>0.00</b>	
														2.5	0.00	0.00	0.00	0.00	0.00	<b>0.00</b>	
2	Standby (Note 22)	x	x	x	x	1	x	x	x	x	x	x	x	1.8	0.00	0.00	0.01	0.00	0.00	<b>0.02</b>	
														2.5	0.00	0.00	0.02	0.00	0.00	<b>0.05</b>	
3	Mono Record	ADC	1	1	1	0	0	1	1	1	11	11	11	11	1.8	0.00	1.67	2.32	0.03	0.00	<b>7.24</b>
															2.5	0.00	1.87	3.72	0.03	0.00	<b>14.05</b>
			1	0	1	0	0	1	1	1	11	11	11	11	1.8	0.00	2.1	2.31	0.03	0.00	<b>7.99</b>
															2.5	0.00	2.3	3.72	0.03	0.00	<b>15.13</b>
			1	0	1	0	0	1	0	0	11	11	11	11	1.8	0.00	3.48	2.32	0.03	0.00	<b>10.49</b>
													2.5	0.00	3.71	3.72	0.03	0.00	<b>18.65</b>		
			1	0	1	0	0	1	0	1	11	11	11	11	1.8	0.00	3.15	2.32	0.03	0.00	<b>9.90</b>
													2.5	0.00	3.37	3.73	0.03	0.00	<b>17.83</b>		
4	Stereo Record	ADC	1	1	0	0	0	1	1	1	11	11	11	11	1.8	0.00	2.31	2.37	0.03	0.00	<b>8.48</b>
															2.5	0.00	2.53	3.82	0.03	0.00	<b>15.95</b>
			0	0	0	0	0	1	1	1	11	11	11	11	1.8	0.00	3.18	2.37	0.03	0.00	<b>10.04</b>
															2.5	0.00	3.42	3.81	0.03	0.00	<b>18.15</b>
			0	0	0	0	0	0	0	1	11	11	11	11	1.8	0.00	5.32	2.37	0.03	0.00	<b>13.90</b>
													2.5	0.00	5.57	3.81	0.03	0.00	<b>23.53</b>		
5	Mono Playback to Headphone	ADC	1	1	1	1	0	1	1	1	10	11	11	11	1.8	1.59	1.99	2.72	0.01	0.00	<b>11.36</b>
															2.5	2.07	2.62	4.27	0.01	0.00	<b>22.43</b>
6	Mono Playback to Speaker	ADC	1	1	1	1	0	1	1	1	11	11	10	10	1.8	0.00	0.20	4.42	0.01	3.30	<b>20.54</b>
															2.5	0.00	0.22	6.77	0.01	3.30	<b>29.71</b>
7	Stereo Playback to Headphone	ADC	1	1	1	1	0	1	1	1	10	10	11	11	1.8	2.77	2.00	2.91	0.01	0.00	<b>13.84</b>
															2.5	3.27	2.63	4.28	0.01	0.00	<b>25.48</b>
8	Stereo Playback to Speaker	ADC	1	1	1	1	0	1	1	1	11	11	10	10	1.8	0.00	0.20	4.38	0.01	3.30	<b>20.47</b>
															2.5	0.00	0.22	6.80	0.01	3.30	<b>29.79</b>
9	Stereo Passthru to Headphone	ADC	1	1	1	1	0	1	1	1	10	10	11	11	1.8	2.79	1.91	1.06	0.01	0.00	<b>10.39</b>
															2.5	3.18	2.14	1.81	0.01	0.00	<b>17.85</b>
10	Mono Record & Playback PGA in (no MIC) to Mono HP	ADC	1	0	1	0	0	1	1	1	11	10	11	11	1.8	1.77	3.95	4.28	0.03	0.00	<b>18.05</b>
															2.5	2.13	4.77	6.63	0.03	0.00	<b>33.90</b>
11	Phone Monitor MIC (w/bias) in to Mono Out	ADC	1	0	1	0	0	1	0	0	11	10	11	11	1.8	1.76	5.33	4.28	0.03	0.00	<b>20.52</b>
															2.5	2.15	6.19	6.69	0.03	0.00	<b>37.65</b>
12	Stereo Record & Playback PGA in (no MIC) to St. HP Out	ADC	0	0	0	0	0	1	1	1	10	10	11	11	1.8	2.76	5.05	4.64	0.03	0.00	<b>22.46</b>
															2.5	3.21	5.90	7.17	0.03	0.00	<b>40.78</b>
13	Stereo Rec. & Full Playback PGA (no MIC) to St. HP & SPK	ADC	0	0	0	0	0	1	1	1	10	10	10	10	1.8	3.49	5.24	7.20	0.03	3.30	<b>40.94</b>
															2.5	3.95	6.10	10.46	0.03	3.30	<b>63.56</b>

20. Unless otherwise noted, test conditions are as follows: All zeros input, slave mode, sample rate = 48 kHz; No load. Digital (VD) and logic (VL) supply current will vary depending on speed mode and master/slave operation.

21.  $\overline{\text{RESET}}$  pin 25 held LO, all clocks and data lines are held LO.

22.  $\overline{\text{RESET}}$  pin 25 held HI, all clocks and data lines are held HI.

23. VL current will slightly increase in master mode.

---

## 4. APPLICATIONS

### 4.1 Overview

#### 4.1.1 Basic Architecture

The CS42L52 is a highly integrated, low power, 24-bit audio CODEC comprised of a stereo analog-to-digital converter (ADC), a stereo digital-to-analog converter (DAC), a digital PWM modulator and two full-bridge power back-ends. The ADC and DAC are designed using multi-bit delta-sigma techniques - the DAC operates at an oversampling ratio of 128Fs and the ADC operates at 64Fs, where Fs is equal to the system sample rate.

The different clock rates maximize power savings while maintaining high performance. The PWM modulator operates at a fixed frequency of 384 kHz. The power FETs are configured for either stereo full-bridge or mono parallel full bridge output. The CODEC operates in one of four sample rate speed modes: Quarter, Half, Single and Double. It accepts and is capable of generating serial port clocks (SCLK, LRCK) derived from an input Master Clock (MCLK).

#### 4.1.2 Line & MIC Inputs

The analog input portion of the CODEC allows selection from and configuration of multiple combinations of stereo and microphone (MIC) sources. Eight line inputs with an option for two balanced MIC inputs, a MIC bias output and a Programmable Gain Amplifier (PGA) comprise the analog front-end.

#### 4.1.3 Line & Headphone Outputs

The analog output portion of the CODEC includes a headphone amplifier capable of driving headphone and line-level loads. An on-chip charge pump creates a negative headphone supply allowing a full-scale output swing centered around ground. This eliminates the need for large DC-Blocking capacitors and allows the amplifier to deliver more power to headphone loads at lower supply voltages.

#### 4.1.4 Speaker Driver Outputs

The Class D power amplifiers drive 8 ohm (stereo) and 4 ohm (mono) speakers directly, without the need for an external filter. The power MOSFETS are powered directly from a battery eliminating the efficiency loss associated with an external regulator. Battery level monitoring and compensation maintains a steady output as battery levels fall. A temperature monitor continually measures the die temperature and registers when predefined thresholds are exceeded. **NOTE:** The CS42L52 should only be used in captive speaker systems where the outputs are permanently tied to the speaker terminals.

#### 4.1.5 Fixed Function DSP Engine

The fixed-function digital signal processing engine processes both the PCM serial input data and ADC output data, allowing a mix between the two. Independent volume control, left/right channel swaps, mono mixes, tone control and limiting functions also comprise the DSP engine.

#### 4.1.6 Beep Generator

The beep generator delivers tones at select frequencies across approximately two octave major scales. With independent volume control, beeps may be configured to occur continuously, periodically, or at single time intervals.

#### 4.1.7 Power Management

Three control registers provide independent power-down control of the ADC, DAC, PGA, MIC pre-amp, MIC bias, Headphone and Speaker outputs, allowing operation in select applications with minimal power consumption.

## 4.2 Analog Inputs

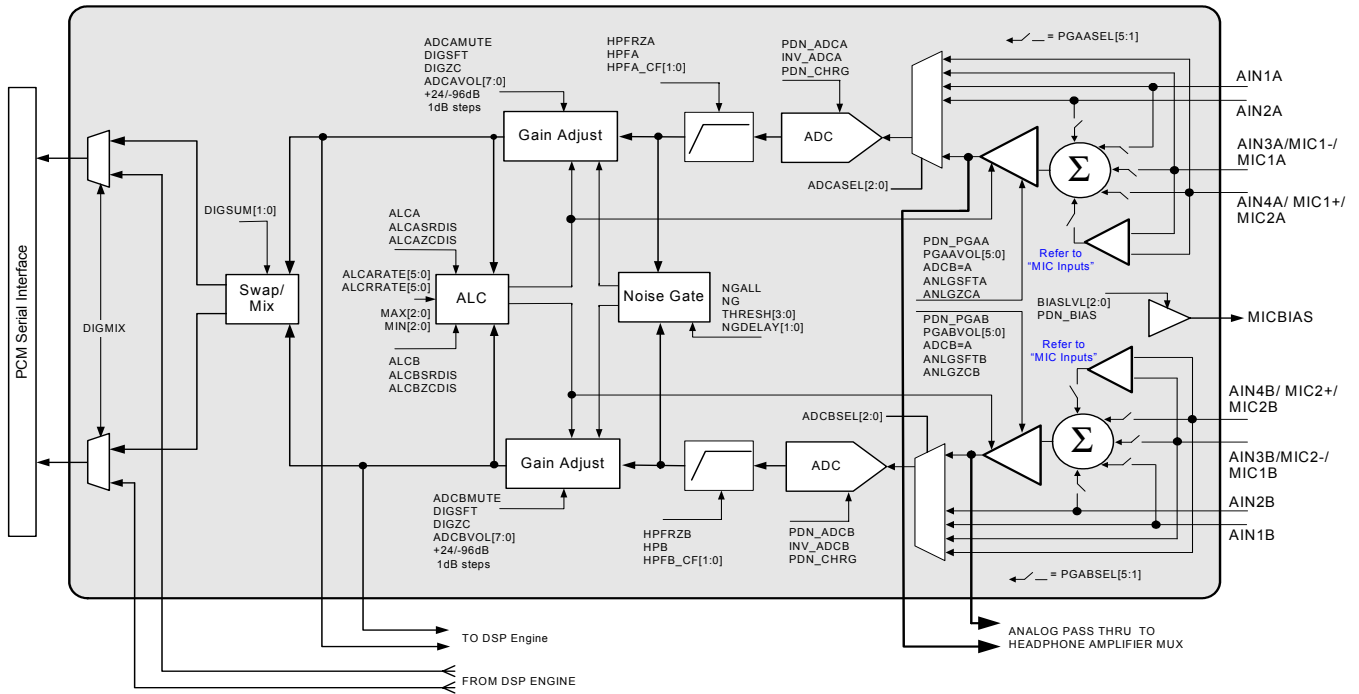

Figure 5. Analog Input Signal Flow

Referenced Control	Register Location
<b>Analog Front End</b>	
PDN_PGAX .....	"Power Down PGAX" on page 42
PGAXVOL[5:0] .....	"PGAX Volume" on page 56
ADCB=A .....	"ADC Channel B=A" on page 50
ANLGSFTx .....	"Ch. x Analog Soft Ramp" on page 49
ANLGZCx .....	"Ch. x Analog Zero Cross" on page 49
ADCxSEL[2:0] .....	"ADC Input Select" on page 48
PGAXSEL5,4,3,2,1 .....	"PGA Input Mapping" on page 49
BIASLVL[2:0] .....	"MIC Bias Level" on page 48
PDN_BIAS .....	"Power Down MIC Bias" on page 43
PDN_ADCx .....	"Power Down ADCx" on page 43
PDN_CHRG .....	"Power Down ADC Charge Pump" on page 42
INV_ADCx .....	"Invert ADC Signal Polarity" on page 50
HPFRZx .....	"ADCx High-Pass Filter Freeze" on page 49
HPFx .....	"ADCx High-Pass Filter" on page 49
HPFx_CF[1:0] .....	"HPF x Corner Frequency" on page 50
ADCxOVFL .....	"ADCx Overflow (Read Only)" on page 71
<b>Digital Volume</b>	
ADCxMUTE .....	"ADC Mute" on page 51
ADCxVOL .....	"ADCx Volume" on page 57
ALCx .....	"ALCx Enable" on page 67
ALCxSRDIS .....	"ALCx Soft Ramp Disable" on page 55
ALCxZCDIS .....	"ALCx Zero Cross Disable" on page 55
ALCARATE[5:0] .....	"ALCx Attack Rate" on page 67
ALCRRATE[5:0] .....	"ALCx Release Rate" on page 68
MAX[2:0] .....	"ALCx Maximum Threshold" on page 68
MIN[2:0] .....	"ALCx Minimum Threshold" on page 69
NGALL .....	"Noise Gate All Channels" on page 69
NG .....	"Noise Gate Enable" on page 69
THRESH[3:0] .....	"Noise Gate Threshold and Boost" on page 70
NGDELAY[1:0] .....	"Noise Gate Delay Timing" on page 70
<b>Miscellaneous</b>	
DIGSUM[1:0] .....	"Digital Sum" on page 50
DIGMUX .....	"Digital MUX" on page 50



### 4.2.1 MIC Inputs

The input pins 21, 22, 23 and 24 accept stereo line-level or microphone signals. For microphone inputs, either single-ended or differential configuration is allowed, providing programmable pre-amplification of low-level signals. In the single-ended configuration, an internal MUX chooses one of two stereo sets (selection is made independently on channels A and B). In the differential configuration, an internal voltage follower cascaded with the pre-amplifier maintains high input impedance and provides noise rejection above the MICxGAIN setting. The pre-amps are biased to VQ in both configurations.

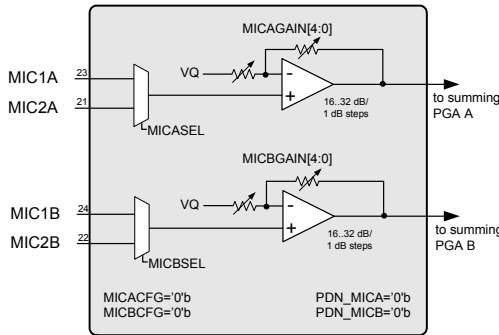

**Figure 6. Single-Ended MIC Configuration**

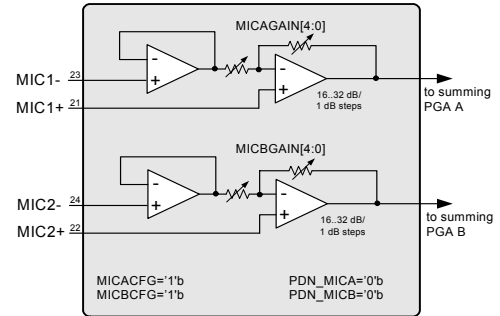

Note: Output to PGA = (MIC<sup>+</sup> - MIC<sup>-</sup>) \* gain + MIC<sup>-</sup>

**Figure 7. Differential MIC Configuration**

Referenced Control	Register Location
MICxCFG .....	"MICx Configuration" on page 55
PDN_MICx .....	"Power Down MICx" on page 43
MICxGAIN .....	"MICx Gain" on page 55

### 4.2.2 Automatic Level Control (ALC)

When enabled, the ALC monitors the analog input signal after the digital attenuator, detects when peak levels exceed the maximum threshold settings and lowers, first, the PGA gain settings and then increases the digital attenuation levels at a programmable attack rate and maintains the resulting level below the maximum threshold.

When input signal levels fall below the minimum threshold, digital attenuation levels are decreased first and the PGA gain is then increased at a programmable release rate and maintains the resulting level above the minimum threshold.

Attack and release rates are affected by the ADC soft ramp/zero cross settings and sample rate, Fs. ALC soft ramp and zero cross dependency may be independently enabled/disabled.

*Recommended settings:* Best level control may be realized with the fastest attack and slowest release setting with soft ramp enabled in the control registers.

**Notes:**

1. When ALC x is enabled and the PGAxVOL[5:0] is set above 12 dB, the ADCxVOL[7:0] should not be set below 0 dB.
2. The maximum realized gain must be set in the PGAxVOL register. The ALC will only apply the gain set in the PGAxVOL.
3. The ALC maintains the output signal between the MIN and MAX thresholds. As the input signal level changes, the level-controlled output may not always be the same but will always fall within the thresholds.

Referenced Control	Register Location
PGAxVOL[5:0]	"PGAx Vol. & ALCx Transition Ctl.: ALC, PGA A (Address 12h) & ALC, PGA B (Address 13h)" on page 55
MAX[2:0], MIN[2:0]	"ALC Threshold (Address 2Ch)" on page 68

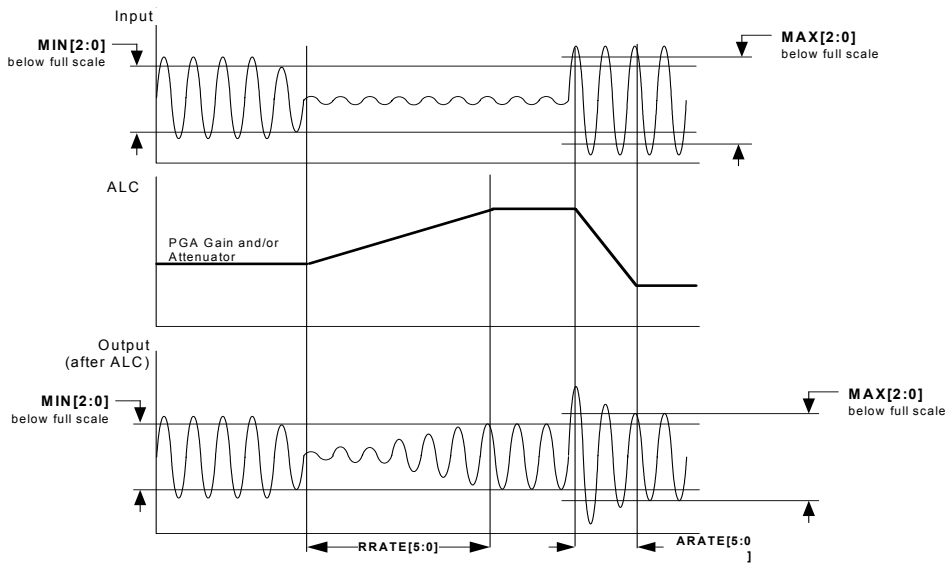
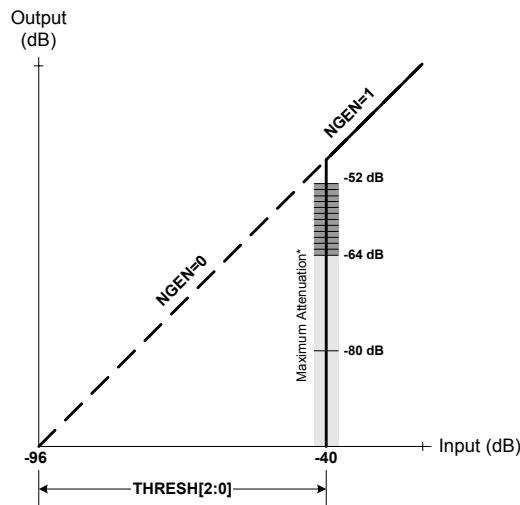

**Figure 8. ALC**

### 4.2.3 Noise Gate

The noise gate may be used to mute signal levels that fall below a programmable threshold. This prevents the ALC from applying gain to noise. A programmable delay may be used to set the minimum time before the noise gate attacks the signal.

**Note:** Maximum noise gate attenuation levels will depend on the gain applied in either the PGA or MIC pre-amplifier. For example: If both +32 dB pre-amplification and +12 dB programmable gain is applied, the maximum attenuation that the noise gate achieves will be 52 dB (-96 + 32 + 12) below full-scale.

Referenced Control	Register Location
Noise Gate Controls.....	"Noise Gate Control (Address 2Dh)" on page 69

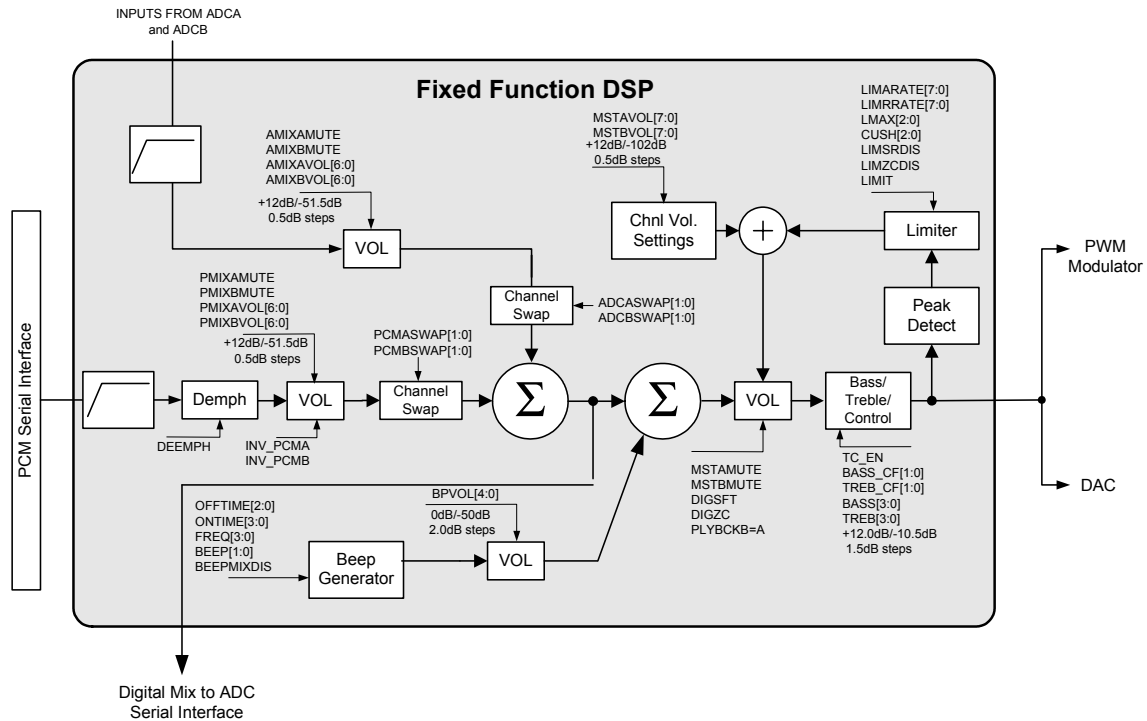
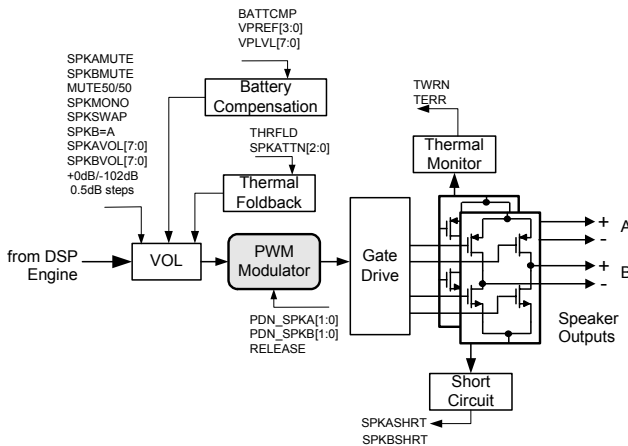
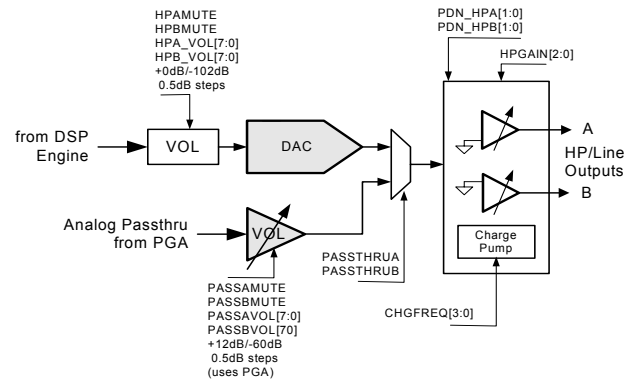

**Figure 9. Noise Gate Attenuation**

### 4.3 Analog Outputs



**Figure 10. DSP Engine Signal Flow**

Referenced Control	Register Location
<b>DSP</b>	
DEEMPH .....	"HP/Speaker De-Emphasis" on page 52
PMIXxMUTE .....	"PCM Mixer Channel x Mute" on page 58
PMIXxVOL[6:0] .....	"PCM Mixer Channel x Volume" on page 58
INV_PCMx .....	"Invert PCM Signal Polarity" on page 51
PCMXSWAP[1:0] .....	"PCM Mix Channel Swap" on page 64
AMIXxMUTE .....	"ADC Mixer Channel x Mute" on page 58
AMIXxVOL[6:0] .....	"ADC Mixer Channel x Volume" on page 58
ADCxSWAP[1:0] .....	"ADC Mix Channel Swap" on page 64
MSTxVOL[7:0] .....	"Master Volume Control" on page 63
MSTxMUTE .....	"Master Playback Mute" on page 51
DIGSFT .....	"Digital Soft Ramp" on page 53
DIGZC .....	"Digital Zero Cross" on page 53
PLYBCKB=A .....	"Playback Volume Setting B=A" on page 51
TC_EN .....	"Tone Control Enable" on page 62
BASS_CF[1:0] .....	"Bass Corner Frequency" on page 62
TREB_CF[1:0] .....	"Treble Corner Frequency" on page 62
BASS[3:0] .....	"Bass Gain" on page 63
TREB[3:0] .....	"Treble Gain" on page 62
LIMIT .....	"Peak Detect and Limiter" on page 66
LIMSRDIS .....	"Limiter Soft Ramp Disable" on page 65
LIMZCDIS .....	"Limiter Zero Cross Disable" on page 66
LMAX[2:0] .....	"Limiter Maximum Threshold" on page 65
CUSH[2:0] .....	"Limiter Cushion Threshold" on page 65
LIMARATE[7:0] .....	"Limiter Attack Rate" on page 67
LIMRRATE[7:0] .....	"Limiter Release Rate" on page 66

**Figure 11. PWM Output Stage**

**Figure 12. Analog Output Stage**

Referenced Control	Register Location
<b>PWM Control</b>	
SPKxMUTE .....	"Speaker Mute" on page 53
MUTE50/50 .....	"Speaker Mute 50/50 Control" on page 54
SPKMONO .....	"Speaker MONO Control" on page 54
SPKxVOL[7:0] .....	"Speaker Volume Control" on page 64
SPKSWAP .....	"Speaker Channel Swap" on page 54
SPKB=A .....	"Speaker Volume Setting B=A" on page 54
BATTCMP .....	"Battery Compensation" on page 71
VPREF[3:0] .....	"VP Reference" on page 72
VPLVL[7:0] .....	"VP Voltage Level (Read Only)" on page 72
THRFLD .....	"Thermal Foldback" on page 73
SPKATTN[2:0] .....	"Speaker Attenuation" on page 74
PDN_SPKx[1:0] .....	"Speaker Power Control" on page 44
RELEASE .....	"Temperature Acknowledge & Release" on page 73
TWRN .....	"Thermal Warning Status (Read Only)" on page 73
TERR .....	"Thermal Error Status (Read Only)" on page 73
SPKxSHRT .....	"Speaker Current Load Status (Read Only)" on page 72

Referenced Control	Register Location
<b>Analog Output</b>	
HPxMUTE .....	"Headphone Mute" on page 53
HPxVOL[7:0] .....	"Headphone Volume Control" on page 63
PDN_HPx[1:0] .....	"Headphone Power Control" on page 44
HPGAIN[2:0] .....	"Headphone Analog Gain" on page 51
PASSTHRUx .....	"Passthru Analog" on page 52
PASSxMUTE .....	"Passthru Mute" on page 52
PASSxVOL[7:0] .....	"Passthru x Volume" on page 56
CHGFREQ .....	"Charge Pump Frequency" on page 74

### 4.3.1 Beep Generator

The Beep Generator generates audio frequencies across approximately two octave major scales. It offers three modes of operation: Continuous, multiple and single (one-shot) beeps. Sixteen on and eight off times are available.

**Note:** The Beep is generated before the limiter and may affect desired limiting performance. If the limiter function is used, it may be required to set the beep volume sufficiently below the threshold to prevent the peak detect from triggering. Since the master volume control, MSTxVOL[7:0], will affect the beep volume, DAC volume may alternatively be controlled using the PMIXxVOL[6:0] bits.

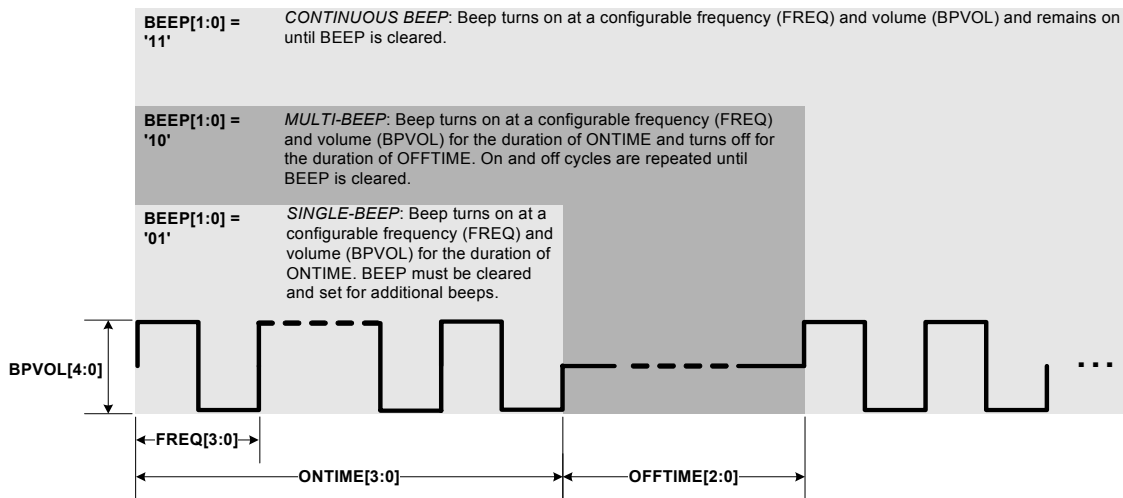

**Figure 13. Beep Configuration Options**

Referenced Control	Register Location
MSTxVOL[7:0].....	"Master Volume Control: MSTA (Address 20h) & MSTB (Address 21h)" on page 63
PMIXxVOL[6:0].....	"PCMx Mixer Volume: PCMA (Address 1Ah) & PCMB (Address 1Bh)" on page 58
OFFTIME[2:0].....	"Beep Off Time" on page 60
ONTIME[3:0].....	"Beep On Time" on page 60
FREQ[3:0].....	"Beep Frequency" on page 59
BEEP[1:0].....	"Beep Configuration" on page 61
BEEP MIX DIS.....	"Beep Mix Disable" on page 61
BPVOL[4:0].....	"Beep Volume" on page 61

### 4.3.2 Limiter

When enabled, the limiter monitors the digital input signal before the DAC and PWM modulators, detects when levels exceed the maximum threshold settings and lowers the master volume at a programmable attack rate below the maximum threshold. When the input signal level falls below the maximum threshold, the AOUT volume returns to its original level set in the Master Volume Control register at a programmable release rate. Attack and release rates are affected by the DAC soft ramp/zero cross settings and sample rate, Fs. Limiter soft ramp and zero cross dependency may be independently enabled/disabled.

#### Notes:

1. *Recommended settings:* Best limiting performance may be realized with the fastest attack and slowest release setting with soft ramp enabled in the control registers. The MIN bits allow the user to set a threshold slightly below the maximum threshold for hysteresis control - this cushions the sound as the limiter attacks and releases.
2. The Limiter maintains the output signal between the MIN and MAX thresholds. As the digital input signal level changes, the level-controlled output may not always be the same but will always fall within the thresholds.

Referenced Control	Register Location
Limiter Controls.....	"Limiter Control 2, Release Rate (Address 28h)" on page 66, "Limiter Attack Rate (Address 29h)" on page 67
Master Volume Control.....	"Master Volume Control: MSTA (Address 20h) & MSTB (Address 21h)" on page 63

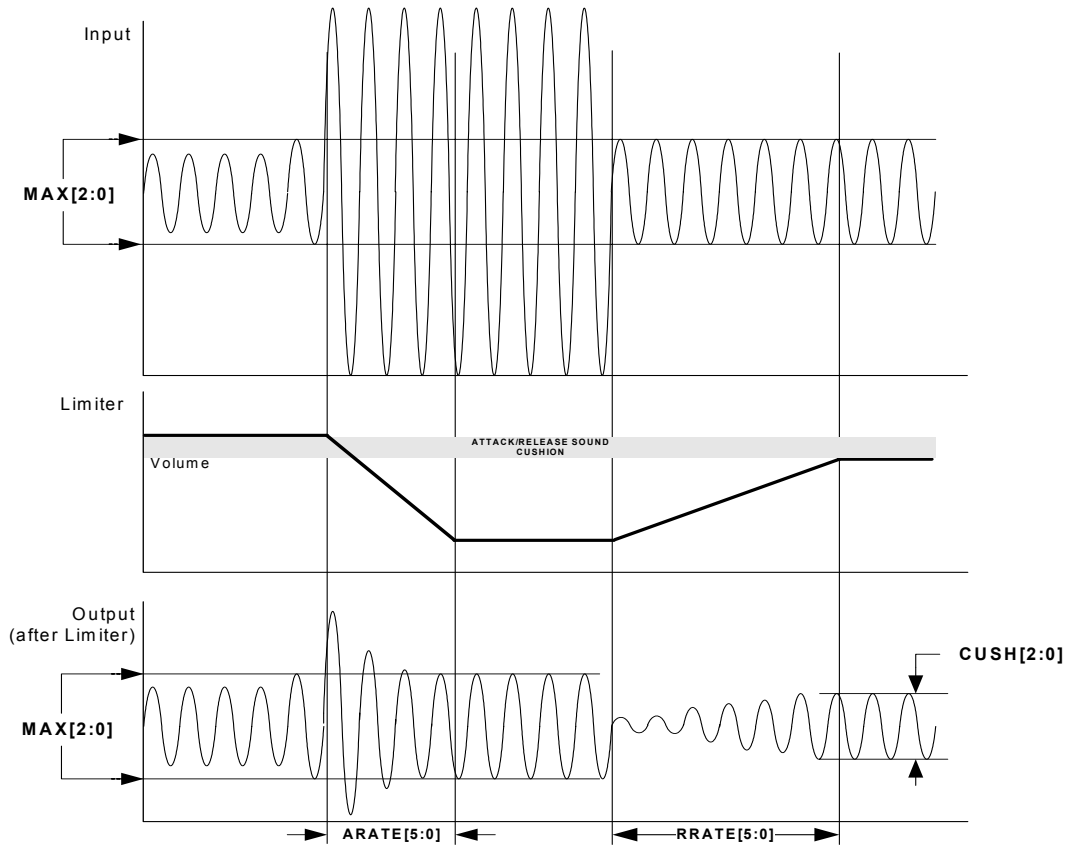

**Figure 14. Peak Detect & Limiter**

#### 4.4 Analog In to Analog Out Passthru

The CS42L52 accommodates analog routing of the analog input signal directly to the headphone amplifiers. This feature is useful in applications that utilize an FM tuner where audio recovered over-the-air must be transmitted to the headphone amplifier without digital conversion in the ADC and DAC. This analog passthru path reduces power consumption and is immune to modulator switching noise that could interfere with some tuners.

##### 4.4.1 Overriding the ADC Power Down

To accommodate automatic activation of the speaker amplifier when the SPK/HP\_SW switch pin changes, the CS42L52 provides the option to automatically power up the ADC whenever the analog signal must route to the digital PWM modulator, regardless of the PDN\_ADC bit. Refer to the table below for how this ADC power-down override functions in accord with the state of the speaker channels. The shaded cells represent normal ADC operation when passthru is disabled.

PDN_ADC	PASSTHRU	PDN_OVRD	Speaker Channel	ADC Status
0	x	x	x	Powered UP
	0	x	x	Powered DOWN
1	1	0	x	Powered DOWN
		1	OFF	Powered DOWN
			ON	Powered UP

When PASSTHRU and PDN\_OVRD are enabled, turning the speaker channel ON (by writing '11'b to SPKx\_PDN[1:0] or by automatic activation of the headphone detect switch, SPK/HP\_SW) will automatically disable the ADCx\_PDN in order to convert the analog input to a digital signal for the PWM modulator. This allows automatic analog input routing to the speaker amplifiers.

Referenced Control	Register Location
PDN_ADCx .....	"Power Down ADCx" on page 43
PASSTHRU .....	"Passthru Analog" on page 52
PDN_OVRD .....	"Power Down ADC Override" on page 43
SPKx_PDN[1:0] .....	"Speaker Power Control" on page 44

#### 4.4.2 Overriding the PGA Power Down

To accommodate automatic activation of the headphone amplifier when the SPK/HP\_SW switch pin changes, the CS42L52 will automatically power up the PGA whenever passthru is enabled, regardless of the PDN\_PGA setting. Refer to the table below for how this PGA power-down override functions in accord with the state of the headphone channels. The shaded cells represent normal PGA operation when Passthru is disabled.

PDN_PGA	PASSTHRU	HP Channel	PGA Status
0	x	x	Powered UP
1	0	x	Powered DOWN
	1	OFF	Powered DOWN
		ON	Powered UP

When Passthru is enabled, turning the headphone channel ON (by writing '1'b to HPx\_PDN[1:0] or by automatic activation of the headphone detect switch, SPK/HP\_SW) will automatically disable the PGAx\_PDN in order to transmit the analog signal to the headphone.

Referenced Control	Register Location
PDN_PGAx .....	"Power Down PGAx" on page 42
PASSTHRU .....	"Passthru Analog" on page 52
HPx_PDN[1:0] .....	"Headphone Power Control" on page 44

## 4.5 PWM Outputs

### 4.5.1 Mono Speaker Output Configuration

The CS42L52 accommodates a stereo as well as a mono speaker output configuration. In mono mode the output drivers of each channel are connected in parallel to deliver maximum power to a 4 ohm speaker. Refer to the table below for pin mapping in mono configuration.

Pin	Speaker Output			
	SPKMONO=0		SPKMONO=1	
	SPKSWAP=0	SPKSWAP=1	SPKSWAP=0	SPKSWAP=1
4	SPKOUTA+	SPKOUTB+	SPKOUTA+	SPKOUTB+
6	SPKOUTA-	SPKOUTB-	SPKOUTA+	SPKOUTB+
7	SPKOUTB+	SPKOUTA+	SPKOUTA-	SPKOUTB-
9	SPKOUTB-	SPKOUTA-	SPKOUTA-	SPKOUTB-

Referenced Control	Register Location
SPKMONO .....	"Speaker MONO Control" on page 54
SPKSWAP .....	"Speaker Channel Swap" on page 54

### 4.5.2 VP Battery Compensation

The CS42L52 provides the option to maintain a desired power output level, independent of the VP supply. When enabled, this feature works by monitoring the voltage on the VP supply and *reducing the attenuation* on the speaker outputs when VP voltage levels fall.

**Note:** The internal ADC that monitors the VP supply operates from the VA supply. Calculations are based on typical VA levels of 1.8 V and 2.5 V using the VPREF bits.

### 4.5.2.1 Maintaining a Desired Output Level

Using SPKxVOL, the speaker output level must first be attenuated by the decibel equivalent of the expected VP supply range (MAX relative to MIN). The CS42L52 then gradually *reduces* the attenuation as the VP supply drops from its maximum level, maintaining a nearly constant power output.

**Compensation Example 1** (VP Battery supply ranges from 4.5 V to 3.0 V)

1. Set speaker attenuation (SPKxVOL) to -3.5 dB. *The VP supply changes ~3.5 dB.*
2. Set the reference VP supply (VPREF) to 4.5 V.
3. Enable battery compensation (BATTCMP).

*The CS42L52 automatically adjusts the output level as the battery discharges.*

**Compensation Example 2** (VP Battery supply ranges from 5.0 V to 1.6 V)

1. Set speaker attenuation (SPKxVOL) to -10 dB. *The VP supply changes ~9.9 dB.*
2. Set the reference VP supply (VPREF) to 5.0 V.
3. Enable battery compensation (BATTCMP).

*The CS42L52 automatically adjusts the output level as the battery discharges. Refer to [Figure 15 on page 34](#). In this example, the VP supply changes over a wide range, illustrating the accuracy of the CS42L52's battery compensation.*

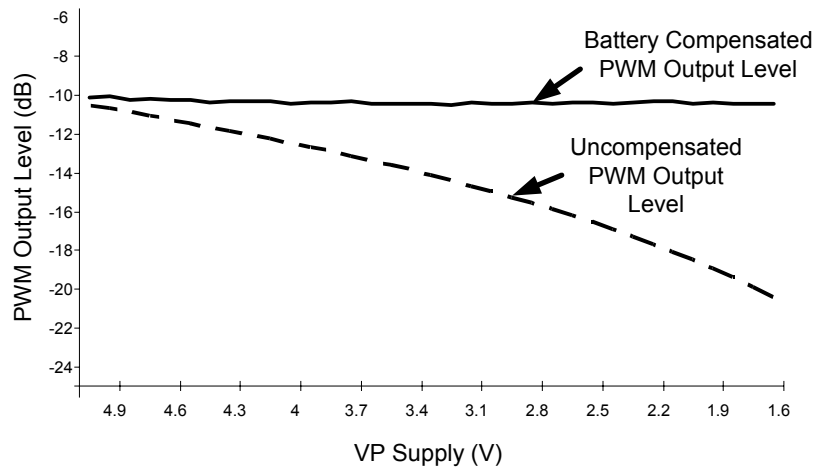

**Figure 15. Battery Compensation**

Referenced Control	Register Location
VPREF .....	"VP Reference" on page 72
SPKxVOL .....	"Speaker Volume Control" on page 64

## 4.6 Serial Port Clocking

The CODEC serial audio interface port operates either as a slave or master, determined by the  $M/\bar{S}$  bit. It accepts externally generated clocks in Slave Mode and will generate synchronous clocks derived from an input master clock (MCLK) in Master Mode. Refer to the tables below for the required setting in register 05h and 06h associated with a given MCLK and sample rate.

Referenced Control	Register Location
$M/\bar{S}$	"Master/Slave Mode" on page 46
Register 05h	"Clocking Control (Address 05h)" on page 44
Register 06h	"Interface Control 1 (Address 06h)" on page 46



MCLK (MHz)	Sample Rate, Fs (kHz)	SPEED[1:0] (AUTO='0'b)	32kGROUP	VIDEOCLK	RATIO[1:0]	MCLKDIV2
12.2880	8.0000	11	1	0	00	0
	12.0000	11	0	0	00	0
	16.0000	10	1	0	00	0
	24.0000	10	0	0	00	0
	32.0000	01	1	0	00	0
	48.0000	01	0	0	00	0
11.2896	96.0000	00	0	0	00	0
	11.0250	11	0	0	00	0
	22.0500	10	0	0	00	0
	44.1000	01	0	0	00	0
18.4320	88.2000	00	0	0	00	0
	8.0000	11	1	0	00	0
	12.0000	11	0	0	00	0
	16.0000	10	1	0	00	0
	24.0000	10	0	0	00	0
	32.0000	01	1	0	00	0
16.9344	48.0000	01	0	0	00	0
	96.0000	00	0	0	00	0
	8.0182	11	0	0	10	0
	11.0250	11	0	0	00	0
	22.0500	10	0	0	00	0
12.0000	44.1000	01	0	0	00	0
	88.2000	00	0	0	00	0
	8.0000	11	1	0	01	0
	11.0294	11	0	0	11	0
	12.0000	11	0	0	01	0
	16.0000	10	1	0	01	0
	22.0588	10	0	0	11	0
	24.0000	10	0	0	01	0
	32.0000	01	1	0	01	0
	44.1176	01	0	0	11	0
24.0000	48.0000	01	0	0	01	0
	88.2353	00	0	0	11	0
	96.0000	00	0	0	01	0
	8.0000	11	1	0	01	1
	11.0294	11	0	0	11	1
	12.0000	11	0	0	01	1
	16.0000	10	1	0	01	1
	22.0588	10	0	0	11	1
	24.0000	10	0	0	01	1
	32.0000	01	1	0	01	1
27.0000	44.1176	01	0	0	11	1
	48.0000	01	0	0	01	1
	88.2353	00	0	0	11	1
	96.0000	00	0	0	01	1
	8.0000	11	1	1	01	0
	12.0000	11	0	1	01	0
	24.0000	10	0	1	01	0
	32.0000	01	1	1	01	0
27.0000	44.1176	01	0	1	11	0
	48.0000	01	0	1	01	0
	11.0294	11	0	1	11	0
	22.0588	10	0	1	11	0
	16.0000	10	1	1	01	0

**Table 1. MCLK, LRCK Quick Decode**

## 4.7 Digital Interface Formats

The serial port operates in standard I<sup>2</sup>S, Left-Justified, Right-Justified (DAC only), or DSP Mode digital interface formats with varying bit depths from 16 to 24. Data is clocked out of the ADC or into the DAC on the rising edge of SCLK.

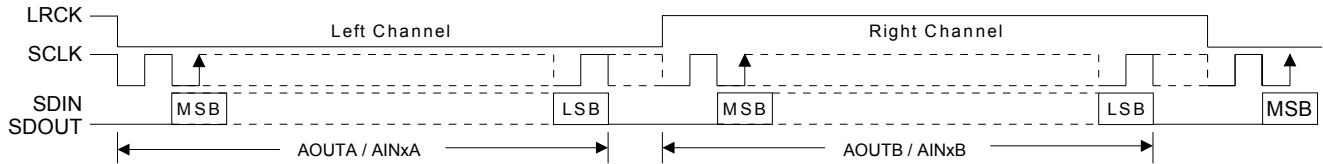

**Figure 16. I<sup>2</sup>S Format**

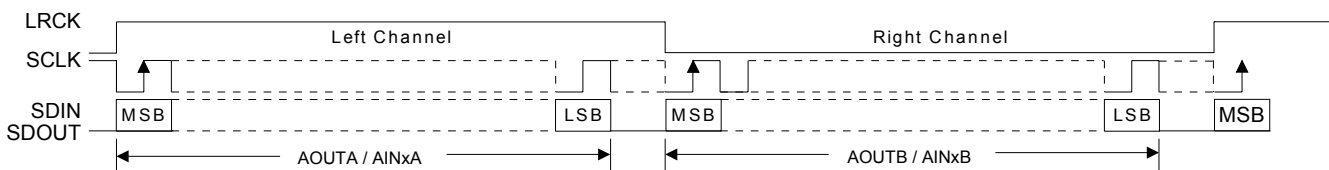

**Figure 17. Left-Justified Format**

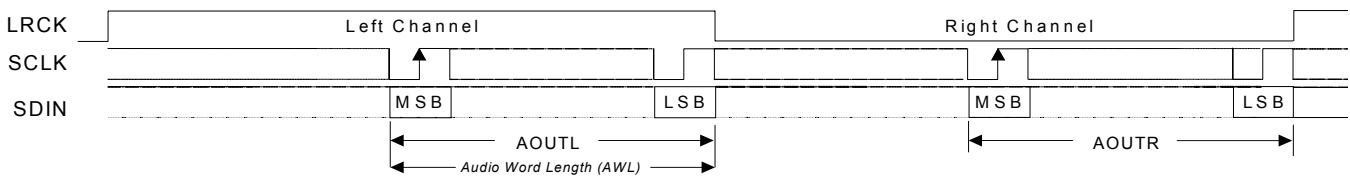

**Figure 18. Right-Justified Format (DAC only)**

### 4.7.1 DSP Mode

In DSP Mode, the LRCK acts as a frame sync for 2 data-packed words (left and right channel) input on SDIN and output on SDOUT. The MSB is input/output on the first SCLK rising edge after the frame sync rising edge. The right channel immediately follows the left channel.

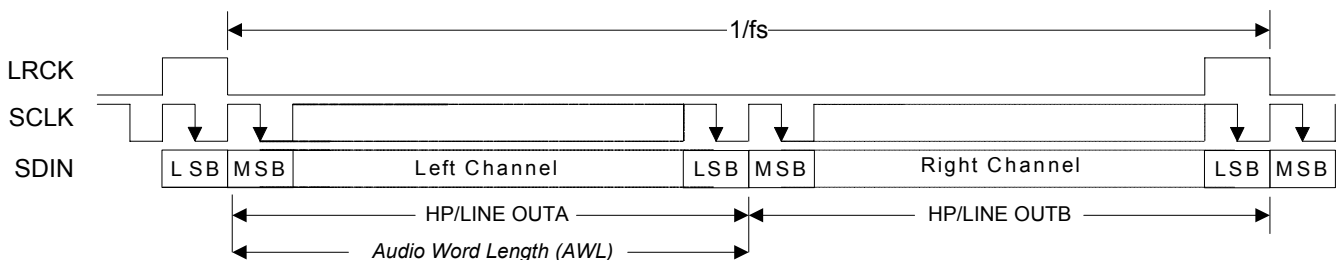

**Figure 19. DSP Mode Format**

## 4.8 Initialization

The CODEC enters a Power-Down state upon initial power-up. The interpolation and decimation filters, delta-sigma and PWM modulators and control port registers are reset. The internal voltage reference, and switched-capacitor low-pass filters are powered down.

The device will remain in the Power-Down state until the  $\overline{\text{RESET}}$  pin is brought high. The control port is accessible once  $\overline{\text{RESET}}$  is high and the desired register settings can be loaded per the interface descriptions in the “[Register Description](#)” on [page 42](#).

Once MCLK is valid, the quiescent voltage, VQ, and the internal voltage reference, FILT+, will begin powering up to normal operation. The charge pump slowly powers up and charges the capacitors. Power is then applied to the headphone amplifiers and switched-capacitor filters, and the analog/digital outputs enter a muted state. Once LRCK is valid, MCLK occurrences are counted over one LRCK period to determine the MCLK/LRCK frequency ratio and normal operation begins.

#### 4.9 Recommended Power-Up Sequence

1. Hold  $\overline{\text{RESET}}$  low until the power supplies are stable.
2. Bring  $\overline{\text{RESET}}$  high.
3. The default state of the PDN bit is ‘1’b. Load the desired register settings while keeping the PDN bit set to ‘1’b.
4. Start MCLK to the appropriate frequency, as discussed in [Section 4.6](#).
5. Set the PDN bit to ‘0’b.
6. Apply LRCK, SCLK and SDIN for normal operation to begin.
7. Bring  $\overline{\text{RESET}}$  low if the analog or digital supplies drop below the recommended operating condition to prevent power glitch related issues.

#### 4.10 Recommended Power-Down Sequence

To minimize audible pops when turning off or placing the CODEC in standby,

1. Mute the DAC’s and ADC’s.
2. Set the PDN bit in the power control register to ‘1’b. The CODEC will not power down until it reaches a fully muted state. Do not remove MCLK until after the part has fully muted. Note that it may be necessary to disable the soft ramp and/or zero cross volume transitions to achieve faster muting/power down.
3. Bring  $\overline{\text{RESET}}$  low.

## 4.11 Control Port Operation

The control port is used to access the registers allowing the CODEC to be configured for the desired operational modes and formats. The operation of the control port may be completely asynchronous with respect to the audio sample rates. However, to avoid potential interference problems, the control port pins should remain static if no operation is required.

The control port operates using an I<sup>2</sup>C interface with the CODEC acting as a slave device.

### 4.11.1 I<sup>2</sup>C Control

SDA is a bidirectional data line. Data is clocked into and out of the part by the clock, SCL. The signal timings for a read and write cycle are shown in [Figure 20](#) and [Figure 21](#). A Start condition is defined as a falling transition of SDA while the clock is high. A Stop condition is defined as a rising transition of SDA while the clock is high. All other transitions of SDA occur while the clock is low. The first byte sent to the CS42L52 after a Start condition consists of a 7-bit chip address field and a R/W bit (high for a read, low for a write).

The upper 7 bits of the address field are fixed at 1001010. To communicate with the CS42L52, the chip address field, which is the first byte sent to the CS42L52, should match 1001010. The eighth bit of the address is the R/W bit. If the operation is a write, the next byte is the Memory Address Pointer (MAP), which selects the register to be read or written. If the operation is a read, the contents of the register pointed to by the MAP will be output. Setting the auto-increment bit in MAP allows successive reads or writes of consecutive registers. Each byte is separated by an acknowledge bit. The ACK bit is output from the CS42L52 after each input byte is read and is input to the CS42L52 from the microcontroller after each transmitted byte.

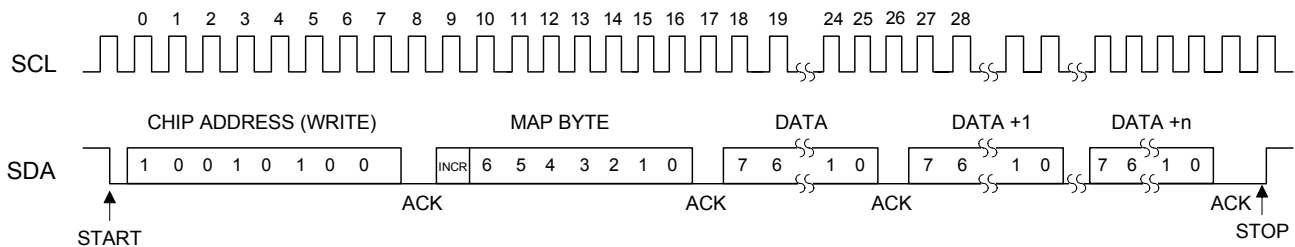

**Figure 20. Control Port Timing, I<sup>2</sup>C Write**

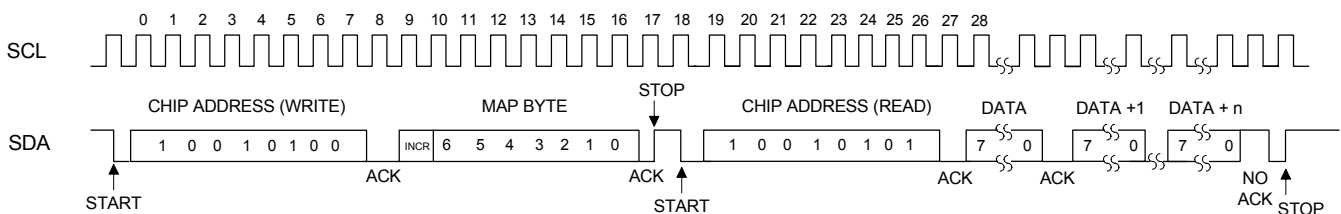

**Figure 21. Control Port Timing, I<sup>2</sup>C Read**

Since the read operation cannot set the MAP, an aborted write operation is used as a preamble. As shown in [Figure 21](#), the write operation is aborted after the acknowledge for the MAP byte by sending a stop condition. The following pseudocode illustrates an aborted write operation followed by a read operation.

```
Send start condition.
Send 10010100 (chip address & write operation).
Receive acknowledge bit.
```

Send MAP byte, auto-increment off.  
Receive acknowledge bit.  
Send stop condition, aborting write.  
Send start condition.  
Send 10010101 (chip address & read operation).  
Receive acknowledge bit.  
Receive byte, contents of selected register.  
Send acknowledge bit.  
Send stop condition.

Setting the auto-increment bit in the MAP allows successive reads or writes of consecutive registers. Each byte is separated by an acknowledge bit.

#### **4.11.2 Memory Address Pointer (MAP)**

The MAP byte comes after the address byte and selects the register to be read or written. Refer to the pseudo code above for implementation details.

##### **4.11.2.1 Map Increment (INCR)**

The device has MAP auto-increment capability enabled by the INCR bit (the MSB) of the MAP. If INCR is set to 0, MAP will stay constant for successive I<sup>2</sup>C writes or reads. If INCR is set to 1, MAP will auto-increment after each byte is read or written, allowing block reads or writes of successive registers.

## 5. REGISTER QUICK REFERENCE

(Default values are shown below the bit names)

I <sup>2</sup> C Address: 1001010[R/W] - 10010100 = 0x94(Write); 10010101 = 0x95(Read)									
Adr.	Function	7	6	5	4	3	2	1	0
01h <a href="#">p 42</a>	ID	CHIPID4 1	CHIPID3 1	CHIPID2 1	CHIPID1 0	CHIPID0 0	REVID2 x	REVID1 x	REVID0 x
02h <a href="#">p 42</a>	Power Ctl 1	PDN_CHRG 0	Reserved 0	Reserved 0	PDN_PGAB 0	PDN_PGAA 0	PDN_ADCB 0	PDN_ADCA 0	PDN 1
03h <a href="#">p 43</a>	Power Ctl 2	Reserved 0	Reserved 0	Reserved 0	OVRDB 0	OVRDA 0	PDN_MICB 1	PDN_MICA 1	PDN_BIAS 1
04h <a href="#">p 44</a>	Power Ctl 3	PDN_HPBB1 0	PDN_HPBB0 0	PDN_HPAA1 0	PDN_HPAA0 0	PDN_SPKB1 0	PDN_SPKB0 1	PDN_SPKA1 0	PDN_SPKA0 1
05h <a href="#">p 44</a>	Clocking Ctl	AUTO 1	SPEED1 0	SPEED0 1	32kGROUP 0	VIDEOCLK 0	RATIO1 0	RATIO0 0	MCLKDIV2 0
06h <a href="#">p 46</a>	Interface Ctl 1	M/S 0	INV_SCLK 0	ADCDF1 0	DSP 0	DACDF1 0	DACDF0 0	AWL1 0	AWL0 0
07h <a href="#">p 47</a>	Interface Ctl 2	Reserved 0	SCLK=MCLK 0	DIGLOOP 0	3ST_SP 0	INV_SWCH 0	BIASLVL2 0	BIASLVL1 0	BIASLVL0 0
08h <a href="#">p 48</a>	Input A Select	ADCASEL2 1	ADCASEL1 0	ADCASEL0 0	PGAASEL5 0	PGAASEL4 0	PGAASEL3 0	PGAASEL2 0	PGAASEL1 1
09h <a href="#">p 48</a>	Input B Select	ADCBSEL2 1	ADCBSEL1 0	ADCBSEL0 0	PGABSEL5 0	PGABSEL4 0	PGABSEL3 0	PGABSEL2 0	PGABSEL1 1
0Ah <a href="#">p 49</a>	Analog, HPF Ctl	HPFB 1	HPFRZB 0	HPFA 1	HPFRZA 0	ANLGSFTB 0	ANLGSFTB 1	ANLGSFTA 0	ANLGSFTA 1
0Bh <a href="#">p 50</a>	ADC HPF Corner Freq.	Reserved 0	Reserved 0	Reserved 0	Reserved 0	HPFB_CF1 0	HPFB_CF0 0	HPFA_CF1 0	HPFA_CF0 0
0Ch <a href="#">p 50</a>	Misc. ADC Ctl	ADCB=A 0	DIGMIX 0	DIGSUM1 0	DIGSUM0 0	INV_ADCB 0	INV_ADCA 0	ADCBMUTE 0	ADCAMUTE 0
0Dh <a href="#">p 51</a>	Playback Ctl 1	HPGAIN2 0	HPGAIN1 1	HPGAIN0 1	PLYBCKB=A 0	INV_PCMB 0	INV_PCMA 0	MSTBMUTE 0	MSTAMUTE 0
0Eh <a href="#">p 52</a>	Misc. Ctl	PASSTHRUB 0	PASSTHRA 0	PASSBMUTE 0	PASSAMUTE 0	FREEZE 0	DEEMPH 0	DIGSFT 1	DIGZC 0
0Fh <a href="#">p 53</a>	Playback Ctl 2	HPBMUTE 0	HPAMUTE 0	SPKBMUTE 0	SPKAMUTE 0	SPKB=A 0	SPKSWAP 0	SPKMONO 0	MUTE50/50 0
10h <a href="#">p 54</a>	MICA Amp Ctl	Reserved 0	MICASEL 0	MICACFG 0	MICAGAIN4 0	MICAGAIN3 0	MICAGAIN2 0	MICAGAIN1 0	MICAGAIN0 0
11h <a href="#">p 54</a>	MICB Amp Ctl	Reserved 0	MICBSEL 0	MICBCFG 0	MICBGAIN4 0	MICBGAIN3 0	MICBGAIN2 0	MICBGAIN1 0	MICBGAIN0 0
12h <a href="#">p 55</a>	PGAA Vol, Misc	ALCASRDIS 0	ALCAZCDIS 0	PGAAVOL5 0	PGAAVOL4 0	PGAAVOL3 0	PGAAVOL2 0	PGAAVOL1 0	PGAAVOL0 0
13h <a href="#">p 55</a>	PGAB Vol, Misc	ALCBSRDIS 0	ALCBZCDIS 0	PGABVOL5 0	PGABVOL4 0	PGABVOL3 0	PGABVOL2 0	PGABVOL1 0	PGABVOL0 0
14h <a href="#">p 56</a>	Passthru A Vol	PASSAVOL7 0	PASSAVOL6 0	PASSAVOL5 0	PASSAVOL4 0	PASSAVOL3 0	PASSAVOL2 0	PASSAVOL1 0	PASSAVOL0 0
15h <a href="#">p 56</a>	Passthru B Vol	PASSBVOL7 0	PASSBVOL6 0	PASSBVOL5 0	PASSBVOL4 0	PASSBVOL3 0	PASSBVOL2 0	PASSBVOL1 0	PASSBVOL0 0
16h <a href="#">p 57</a>	ADCA Vol	ADCAVOL7 0	ADCAVOL6 0	ADCAVOL5 0	ADCAVOL4 0	ADCAVOL3 0	ADCAVOL2 0	ADCAVOL1 0	ADCAVOL0 0
17h <a href="#">p 57</a>	ADCB Vol	ADCBVOL7 0	ADCBVOL6 0	ADCBVOL5 0	ADCBVOL4 0	ADCBVOL3 0	ADCBVOL2 0	ADCBVOL1 0	ADCBVOL0 0
18h <a href="#">p 58</a>	ADCMIXA Vol	AMIXAMUTE 1	AMIXAVOL6 0	AMIXAVOL5 0	AMIXAVOL4 0	AMIXAVOL3 0	AMIXAVOL2 0	AMIXAVOL1 0	AMIXAVOL0 0
19h <a href="#">p 58</a>	ADCMIXB Vol	AMIXBMUTE 1	AMIXBVOL6 0	AMIXBVOL5 0	AMIXBVOL4 0	AMIXBVOL3 0	AMIXBVOL2 0	AMIXBVOL1 0	AMIXBVOL0 0
1Ah <a href="#">p 58</a>	PCMMIXA Vol	PMIXAMUTE 0	PMIXAVOL6 0	PMIXAVOL5 0	PMIXAVOL4 0	PMIXAVOL3 0	PMIXAVOL2 0	PMIXAVOL1 0	PMIXAVOL0 0

I <sup>2</sup> C Address: 1001010[R/W] - 10010100 = 0x94(Write); 10010101 = 0x95(Read)									
Adr.	Function	7	6	5	4	3	2	1	0
1Bh p 58	PCMMIXB Vol	PMIXBMUTE 0	PMIXBVOL6 0	PMIXBVOL5 0	PMIXBVOL4 0	PMIXBVOL3 0	PMIXBVOL2 0	PMIXBVOL1 0	PMIXBVOL0 0
1Ch p 59	BEEP Freq, On Time	FREQ3 0	FREQ2 0	FREQ1 0	FREQ0 0	ONTIME3 0	ONTIME2 0	ONTIME1 0	ONTIME0 0
1Dh p 60	BEEP Vol, Off Time	OFFTIME2 0	OFFTIME1 0	OFFTIME0 0	BPVOL4 0	BPVOL3 0	BPVOL2 0	BPVOL1 0	BPVOL0 0
1Eh p 61	BEEP, Tone Cfg.	BEEP1 0	BEEP0 0	BEEPPIXDIS 0	TREB_CF1 0	TREB_CF0 0	BASS_CF1 0	BASS_CF0 0	TC_EN 0
1Fh p 62	Tone Ctl	TREB3 1	TREB2 0	TREB1 0	TREB0 0	BASS3 1	BASS2 0	BASS1 0	BASS0 0
20h p 63	Master A Vol	MSTAVOL7 0	MSTAVOL6 0	MSTAVOL5 0	MSTAVOL4 0	MSTAVOL3 0	MSTAVOL2 0	MSTAVOL1 0	MSTAVOL0 0
21h p 63	Master B Vol	MSTBVOL7 0	MSTBVOL6 0	MSTBVOL5 0	MSTBVOL4 0	MSTBVOL3 0	MSTBVOL2 0	MSTBVOL1 0	MSTBVOL0 0
22h p 63	Headphone A Volume	HPAVOL7 0	HPAVOL6 0	HPAVOL5 0	HPAVOL4 0	HPAVOL3 0	HPAVOL2 0	HPAVOL1 0	HPAVOL0 0
23h p 63	Headphone B Volume	HPBVOL7 0	HPBVOL6 0	HPBVOL5 0	HPBVOL4 0	HPBVOL3 0	HPBVOL2 0	HPBVOL1 0	HPBVOL0 0
24h p 64	Speaker A Volume	SPKAVOL7 0	SPKAVOL6 0	SPKAVOL5 0	SPKAVOL4 0	SPKAVOL3 0	SPKAVOL2 0	SPKAVOL1 0	SPKAVOL0 0
25h p 64	Speaker B Volume	SPKBVOL7 0	SPKBVOL6 0	SPKBVOL5 0	SPKBVOL4 0	SPKBVOL3 0	SPKBVOL2 0	SPKBVOL1 0	SPKBVOL0 0
26h p 64	Channel Mixer & Swap	PCMASWP1 0	PCMASWP0 0	PCBMSWP1 0	PCBMSWP0 0	ADCASWP1 0	ADCASWP0 0	ADCBSWP1 0	ADCBSWP0 0
27h p 65	Limit Ctl 1, Thresholds	LMAX2 0	LMAX1 0	LMAX0 0	CUSH2 0	CUSH1 0	CUSH0 0	LIMSRDIS 0	LIMZCDIS 0
28h p 66	Limit Ctl 2, Release Rate	LIMIT 0	LIMIT_ALL 1	LIMRRATE5 1	LIMRRATE4 1	LIMRRATE3 1	LIMRRATE2 1	LIMRRATE1 1	LIMRRATE0 1
29h p 67	Limiter Attack Rate	Reserved 1	Reserved 1	LIMARATE5 0	LIMARATE4 0	LIMARATE3 0	LIMARATE2 0	LIMARATE1 0	LIMARATE0 0
2Ah p 67	ALC Ctl 1, Attack Rate	ALCB 0	ALCA 0	ALCARATE5 0	AALCRATE4 0	ALCARATE3 0	ALCARATE2 0	ALCARATE1 0	ALCARATE0 0
2Bh p 68	ALC Release Rate	Reserved 0	Reserved 0	ALCRRATE5 1	ALCRRATE4 1	ALCRRATE3 1	ALCRRATE2 1	ALCRRATE1 1	ALCRRATE0 1
2Ch p 68	ALC Thresh- olds	ALCMAX2 0	ALCMAX1 0	ALCMAX0 0	ALCMIN2 0	ALCMIN1 0	ALCMIN0 0	Reserved 0	Reserved 0
2Dh p 69	Noise Gate Ctl	NGALL 0	NG 0	NGBOOST 0	THRESH2 0	THRESH1 0	THRESH0 0	NGDELAY1 0	NGDELAY0 0
2Eh p 70	Overflow & Clock Status	Reserved 0	SPCLKERR 0	DSPBOVFL 0	DSPAOVFL 0	PCMAOVFL 0	PCMBOVFL 0	ADCAOVFL 0	ADCBOVFL 0
2Fh p 71	Battery Com- pensation	BATTCMP 0	VPMONITOR 0	Reserved 0	Reserved 0	VPREF3 0	VPREF2 0	VPREF1 0	VPREF0 0
30h p 72	VP Battery Level	VPLVL7 0	VPLVL6 0	VPLVL5 0	VPLVL4 0	VPLVL3 0	VPLVL2 0	VPLVL1 0	VPLVL0 0
31h p 72	Speaker Status	Reserved 0	Reserved 0	SPKASHRT 0	SPKBSHRT 0	SPKR/HP 0	Reserved 0	TWRN 0	TERR 0
32h p 73	Temperature Monitor Control	RELEASE 0	Reserved 0	Reserved 1	Reserved 1	Reserved 1	Reserved 0	Reserved 1	Reserved 1
33h p 73	Thermal Fold- back	Reserved 0	Reserved 0	Reserved 0	Reserved 0	THRFLD 0	SPKATTN2 0	SPKATTN1 0	SPKATTN0 0
34h p 74	Charge Pump Frequency	CHGFREQ3 0	CHGFREQ2 1	CHGFREQ1 0	CHGFREQ0 1	Reserved 1	Reserved 1	Reserved 1	Reserved 1

## 6. REGISTER DESCRIPTION

All registers are read/write except for the chip I.D. and Revision Register and Interrupt Status Register which are read only. See the following bit definition tables for bit assignment information. The default state of each bit after a power-up sequence or reset is listed in each bit description. All “Reserved” bits must maintain their default value.

### 6.1 Chip I.D. and Revision Register (Address 01h) (Read Only)

7	6	5	4	3	2	1	0
CHIPID4	CHIPID3	CHIPID2	CHIPID1	CHIPID0	REVID2	REVID1	REVID0

#### 6.1.1 Chip I.D. (Read Only)

I.D. code for the CS42L52.

CHIPID[4:0]	Device
11100	CS42L52

#### 6.1.2 Chip Revision (Read Only)

CS42L52 revision level.

REVID[2:0]	Revision Level
000	A0
001	A1
010	B0

### 6.2 Power Control 1 (Address 02h)

7	6	5	4	3	2	1	0
PDN_CHRG	Reserved	Reserved	PDN_PGAB	PDN_PGAA	PDN_ADCB	PDN_ADCA	PDN

#### 6.2.1 Power Down ADC Charge Pump

Configures the power state of the ADC charge pump.

PDN_CHRG	ADC Charge Pump Status
0	Powered Up
1	Powered Down

#### 6.2.2 Power Down PGAx

Configures the power state of PGA channel x.

PDN_PGAx	PGA Status
0	Powered Up (ONLY when the ADC or the analog passthru is used)
1	Powered Down
Application	<a href="#">“Analog In to Analog Out Passthru” on page 32</a>

#### Notes:

1. The CS42L52 employs a clever scheme for controlling the power to the PGA when PASSTHRU (“Passthru Analog” on page 52) is enabled. Refer to the referenced application for more information.
2. This bit is also used in conjunction with AINx\_SEL bits to determine the analog input path to the ADC. Refer to “ADC Input Select” on page 48 for the required settings.



### 6.2.3 Power Down ADCx

Configures the power state of ADC channel x.

PDN_ADCx	ADC Status
0	Powered Up
1	Powered Down
<b>Application</b>	<a href="#">"Analog In to Analog Out Passthru" on page 32</a>

**Notes:**

1. The CS42L52 employs a clever scheme for controlling the power to the ADC when PASSTHRU (["Passthru Analog" on page 52](#)) and PDN\_OVRD (["Power Down ADC Override" on page 43](#)) are enabled. Refer to the referenced application.

### 6.2.4 Power Down

Configures the power state of the entire CODEC.

PDN	CODEC Status
0	Powered Up
1	Powered Down

## 6.3 Power Control 2 (Address 03h)

7	6	5	4	3	2	1	0
Reserved	Reserved	Reserved	OVRDB	OVRDA	PDN_MICB	PDN_MICA	PDN_BIAS

### 6.3.1 Power Down ADC Override

Configures an override of the power down control for ADCx.

OVRDx	PDN_ADC Override
0	Disable
1	Enable
<b>Application</b>	<a href="#">"Analog In to Analog Out Passthru" on page 32</a>

### 6.3.2 Power Down MICx

Configures the power state of the microphone pre-amplifier for channel x.

PDN_MICx	MIC Pre-Amp Status
0	Powered Up
1	Powered Down
<b>Application</b>	<a href="#">"MIC Inputs" on page 27</a>

### 6.3.3 Power Down MIC Bias

Configures the power state of the microphone bias circuit.

PDN_BIAS	MIC Bias Status
0	Powered Up
1	Powered Down

## 6.4 Power Control 3 (Address 04h)

7	6	5	4	3	2	1	0
PDN_HP B1	PDN_HP B0	PDN_HP A1	PDN_HP A0	PDN_SPK B1	PDN_SPK B0	PDN_SPK A1	PDN_SPK A0

### 6.4.1 Headphone Power Control

Configures how the SPK/HP\_SW pin, 6, controls the power for the headphone amplifier.

PDN_HPx[1:0]	Headphone Status
00	Headphone channel is ON when the SPK/HP_SW pin, 6, is LO. Headphone channel is OFF when the SPK/HP_SW pin, 6, is HI.
01	Headphone channel is ON when the SPK/HP_SW pin, 6, is HI. Headphone channel is OFF when the SPK/HP_SW pin, 6, is LO.
10	Headphone channel is always ON.
11	Headphone channel is always OFF.

### 6.4.2 Speaker Power Control

Configures how the SPK/HP\_SW pin, 6, controls the power for the speaker amplifier.

PDN_SPKx[1:0]	Speaker Status
00	Speaker channel is ON when the SPK/HP_SW pin, 6, is LO. Speaker channel is OFF when the SPK/HP_SW pin, 6, is HI.
01	Speaker channel is ON when the SPK/HP_SW pin, 6, is HI. Speaker channel is OFF when the SPK/HP_SW pin, 6, is LO.
10	Speaker channel is always ON.
11	Speaker channel is always OFF.

## 6.5 Clocking Control (Address 05h)

7	6	5	4	3	2	1	0
AUTO	SPEED1	SPEED0	32k_GROUP	VIDEOCLK	RATIO1	RATIO0	MCLKDIV2

### 6.5.1 Auto-Detect

Configures the auto-detect circuitry for detecting the speed mode of the CODEC when operating as a slave.

AUTO	Auto-detection of Speed Mode
0	Disabled
1	Enabled
<b>Application:</b>	<a href="#">"Serial Port Clocking" on page 34</a>

#### Notes:

1. The SPEED[1:0] bits are ignored and speed is determined by the MCLK/LRCK ratio.
2. When AUTO is disabled and the CODEC operates in master mode, the MCLKDIV2 bit is ignored.
3. Certain sample and MCLK frequencies require setting the SPEED[1:0] bits, the 32k\_GROUP bit (["32kHz Sample Rate Group" on page 45](#)) and/or the VIDEOCLK bit (["27 MHz Video Clock" on page 45](#)) and RATIO[1:0] bits (["Internal MCLK/LRCK Ratio" on page 45](#)). Low sample rates may also affect dynamic range performance in the typical audio band. Refer to the referenced application for more information.

### 6.5.2 Speed Mode

Configures the speed mode of the CODEC in slave mode and sets the appropriate MCLK divide ratio for LRCK and SCLK in master mode.

SPEED[1:0]	Slave Mode	Master Mode	
	Serial Port Speed	MCLK/LRCK Ratio	SCLK/LRCK Ratio
00	Double-Speed Mode (DSM - 50 kHz -100 kHz Fs)	512	64
01	Single-Speed Mode (SSM - 4 kHz -50 kHz Fs)	256	64
10	Half-Speed Mode (HSM - 12.5kHz -25 kHz Fs)	128	64
11	Quarter-Speed Mode (QSM - 4 kHz -12.5 kHz Fs)	128	64
<b>Application:</b>	"Serial Port Clocking" on page 34		

#### Notes:

1. Slave/Master Mode is determined by the  $\overline{M/\overline{S}}$  bit in "Master/Slave Mode" on page 46.
2. Certain sample and MCLK frequencies require setting the SPEED[1:0] bits, the 32k\_GROUP bit ("32kHz Sample Rate Group" on page 45) and/or the VIDEOCLK bit ("27 MHz Video Clock" on page 45) and RATIO[1:0] bits ("Internal MCLK/LRCK Ratio" on page 45). Low sample rates may also affect dynamic range performance in the typical audio band. Refer to the referenced application for more information.
3. These bits are ignored when the AUTO bit ("Auto-Detect" on page 44) is enabled.

### 6.5.3 32kHz Sample Rate Group

Specifies whether or not the input/output sample rate is 8 kHz, 16 kHz or 32 kHz.

32kGROUP	8 kHz, 16 kHz or 32 kHz sample rate?
0	No
1	Yes
<b>Application:</b>	"Serial Port Clocking" on page 34

### 6.5.4 27 MHz Video Clock

Specifies whether or not the external MCLK frequency is 27 MHz

VIDEOCLK	27 MHz MCLK?
0	No
1	Yes
<b>Application:</b>	"Serial Port Clocking" on page 34

### 6.5.5 Internal MCLK/LRCK Ratio

Configures the internal MCLK/LRCK ratio.

RATIO[1:0]	Internal MCLK Cycles per LRCK	SCLK/LRCK Ratio in Master Mode
00	128	64
01	125	62
10	132	66
11	136	68
<b>Application:</b>	"Serial Port Clocking" on page 34	

### 6.5.6 MCLK Divide By 2

Divides the input MCLK by 2 prior to all internal circuitry.

MCLKDIV2	MCLK signal into CODEC
0	No divide
1	Divided by 2
<b>Application:</b>	<a href="#">"Serial Port Clocking" on page 34</a>

**Note:** In slave mode, this bit is ignored when the AUTO bit (["Auto-Detect" on page 44](#)) is disabled.

## 6.6 Interface Control 1 (Address 06h)

7	6	5	4	3	2	1	0
M/S	INV_SCLK	ADCDIF	DSP	DACDIF1	DACDIF0	AWL1	AWL0

### 6.6.1 Master/Slave Mode

Configures the serial port I/O clocking.

M/S	Serial Port Clocks
0	Slave (input ONLY)
1	Master (output ONLY)

### 6.6.2 SCLK Polarity

Configures the polarity of the SCLK signal.

INV_SCLK	SCLK Polarity
0	Not Inverted
1	Inverted

### 6.6.3 ADC Interface Format

Configures the digital interface format for data on SDOUT.

ADCDIF	ADC Interface Format
0	Left Justified
1	I <sup>2</sup> S
<b>Application:</b>	<a href="#">"Digital Interface Formats" on page 36</a>

### 6.6.4 DSP Mode

Configures a data-packed interface format for both the ADC and DAC.

DSP	DSP Mode
0	Disabled
1	Enabled
<b>Application:</b>	<a href="#">"DSP Mode" on page 36</a>

**Notes:**

1. Select the audio word length using the AWL[1:0] bits (["Audio Word Length" on page 47](#)).
2. The interface format for both the ADC and the DAC must be set to "Left-Justified" when DSP Mode is enabled.

### 6.6.5 DAC Interface Format

Configures the digital interface format for data on SDIN.

DACDIF[1:0]	DAC Interface Format
00	Left Justified, up to 24-bit data
01	I <sup>2</sup> S, up to 24-bit data
10	Right Justified
11	Reserved
<b>Application:</b>	<a href="#">"Digital Interface Formats" on page 36</a>

**Note:** Select the audio word length for Right Justified using the AWL[1:0] bits (["Audio Word Length" on page 47](#)).

### 6.6.6 Audio Word Length

Configures the audio sample word length used for the data into SDIN and out of SDOOUT.

AWL[1:0]	Audio Word Length	
	DSP Mode	Right Justified (DAC ONLY)
00	32-bit data	24-bit data
01	24-bit data	20-bit data
10	20-bit data	18-bit data
11	16-bit data	16-bit data
<b>Application:</b>	<a href="#">"DSP Mode" on page 36</a>	

**Note:** When the internal MCLK/LRCK ratio is set to 125 in master mode, the 32-bit data width option for DSP Mode is not valid unless SCLK=MCLK.

## 6.7 Interface Control 2 (Address 07h)

7	6	5	4	3	2	1	0
Reserved	SCLK=MCLK	DIGLOOP	3ST_SP	INV_SWCH	BIASLVL2	BIASLVL1	BIASLVL0

### 6.7.1 SCLK equals MCLK

Configures the SCLK signal source for master mode.

SCLK=MCLK	Output SCLK
0	Re-timed signal, synchronously derived from MCLK
1	Non-retimed, MCLK signal

**Note:** This bit is only valid for MCLK = 12.0000 MHz.

### 6.7.2 SDOOUT to SDIN Digital Loopback

Configures an internal loops the signal on the SDOOUT pin to SDIN.

DIGLOOP	Internal Loopback
0	Disabled; SDOOUT internally disconnected from SDIN
1	Enabled; SDOOUT internally connected to SDIN

### 6.7.3 Tri-State Serial Port Interface

Determines the state of the serial port drivers.

3ST_SP	Serial Port Status	
	Slave Mode	Master Mode
0	Serial Port clocks are inputs and SDOUT is output	Serial Port clocks and SDOUT are outputs
1	Serial Port clocks are inputs and SDOUT is HI-Z	Serial Port clocks and SDOUT are HI-Z

**Notes:**

1. Slave/Master Mode is determined by the M/ $\bar{S}$  bit in “[Master/Slave Mode](#)” on page 46.
2. When the serial port is tri-stated in master mode, the ADC and DAC serial ports are clocked internally.

### 6.7.4 Speaker/Headphone Switch Invert

Determines the control signal polarity of the SPK/HP\_SW pin.

INV_SWCH	SPK/HP_SW pin 6 Control
0	Not inverted
1	Inverted

### 6.7.5 MIC Bias Level

Sets the output voltage level on the MICBIAS output pin.

BIASLVL[2:0]	Output Bias Level
000	0.5 x VA
001	0.6 x VA
010	0.7 x VA
011	0.8 x VA
100	0.83 x VA
101	0.91 x VA
110	Reserved
111	Reserved

## 6.8 Input x Select: ADCA and PGAA (Address 08h), ADCB and PGAB (Address 09h)

7	6	5	4	3	2	1	0
ADCASEL2	ADCASEL1	ADCASEL0	PGAASEL5	PGAASEL4	PGAASEL3	PGAASEL2	PGAASEL1

### 6.8.1 ADC Input Select

Selects the specified analog input signal into ADCx.

ADCxSEL[2:0]	Selected Input to ADCx
000	AIN1x
001	AIN2x
010	AIN3x
011	AIN4x
100	PGAx - Use PGAxSEL bits (“ <a href="#">PGA Input Mapping</a> ” on page 49) to select input channels
101	Reserved
110	Reserved
111	Reserved
<b>Application:</b>	“ <a href="#">Analog Inputs</a> ” on page 26

## 6.8.2 PGA Input Mapping

Selects one or sums/mixes the analog input signal into the PGA. Each bit of the PGAx\_SEL[5:1] word corresponds to individual channels (i.e. PGAx\_SEL1 selects AIN1x, PGAx\_SEL2 selects AIN2x, etc.).

PGAxSEL[5:1]	Selected Input to PGAx (Examples)
00000	No inputs selected
00001	AIN1x
00010	AIN2x
00100	AIN3x
01000	AIN4x
10000	MICx; for single-ended MIC inputs, use MICxSEL ("MIC x Select" on page 54) to select MIC 1 or MIC 2; for differential MIC inputs, enable MICxCFG ("MICx Configuration" on page 55)
10001	MICx + AIN1x
10011	MICx + AIN1x + AIN2x
<b>Application:</b>	"Analog Inputs" on page 26

Note: Table does not show all possible combinations.

## 6.9 Analog & HPF Control (Address 0Ah)

7	6	5	4	3	2	1	0
HPFB	HPFRZB	HPFA	HPFRZA	ANLGSFTB	ANLGZCB	ANLGSFTA	ANLGZCA

### 6.9.1 ADCx High-Pass Filter

Configures the internal high-pass filter after ADCx.

HPFx	High Pass Filter Status
0	Disabled
1	Enabled

### 6.9.2 ADCx High-Pass Filter Freeze

Configures the high pass filter's digital DC subtraction and/or calibration after ADCx.

HPFRZx	High Pass Filter Digital Subtraction
0	Continuous DC Subtraction
1	Frozen DC Subtraction

### 6.9.3 Ch. x Analog Soft Ramp

Configures an incremental volume ramp from the current level to the new level at the specified rate.

ANLGSFTx	Volume Changes	Affected Analog Volume Controls
0	Do not occur with a soft ramp	MICxGAIN[4:0] ("MICx Gain" on page 55), PGAxVOL[5:0] ("PGAx Volume" on page 56), and PASSxVOL[7:0] ("Passthru x Volume" on page 56)
1	Occur with a soft ramp	
<b>Ramp Rate:</b>	1/2 dB every 16 LRCK cycles	

### 6.9.4 Ch. x Analog Zero Cross

Configures when the signal level changes occur for the analog volume controls.

ANLGZCx	Volume Changes	Affected Analog Volume Controls
0	Do not occur on a zero crossing	MICxGAIN[4:0] ("MICx Gain" on page 55), PGAxVOL[5:0] ("PGAx Volume" on page 56), and PASSxVOL[7:0] ("Passthru x Volume" on page 56)
1	Occur on a zero crossing	

**Note:** If the signal does not encounter a zero crossing, the requested volume change will occur after a timeout period of 1024 sample periods (approximately 10.7 ms at 48 kHz sample rate).

## 6.10 ADC HPF Corner Frequency (Address 0Bh)

7	6	5	4	3	2	1	0
Reserved	Reserved	Reserved	Reserved	HPFB_CF1	HPFB_CF0	HPFA_CF1	HPFA_CF0

### 6.10.1 HPF x Corner Frequency

Sets the corner frequency (-3 dB point) for the internal High-Pass Filter (HPF).

HPFx_CF[1:0]	HPF Corner Frequency Setting ( $F_s=48$ kHz)
00	Normal setting as specified in <a href="#">“ADC Digital Filter Characteristics” on page 14</a>
01	119 Hz
10	236 Hz
11	464 Hz

## 6.11 Misc. ADC Control (Address 0Ch)

7	6	5	4	3	2	1	0
ADCB=A	DIGMUX	DIGSUM1	DIGSUM0	INV_ADCB	INV_ADCA	ADCBMUTE	ADCBMUTE

### 6.11.1 ADC Channel B=A

Configures independent or ganged control of the MIC, PGA, Passthru, ADC and the ALC.

ADCB=A	Single Volume Control
0	Disabled
1	Enabled

### 6.11.2 Digital MUX

Selects the signal source for the ADC serial port

DIGMUX	SDOUT Signal Source
0	ADC
1	DSP

### 6.11.3 Digital Sum

Configures a mix/swap of ADCA and ADCB.

DIGSUM[1:0]	Serial Output Signal	
	Left Channel	Right Channel
00	ADCA	ADCB
01	$(ADCA + ADCB)/2$	$(ADCA + ADCB)/2$
10	$(ADCA - ADCB)/2$	$(ADCA - ADCB)/2$
11	ADCB	ADCA

### 6.11.4 Invert ADC Signal Polarity

Configures the polarity of the ADC signal.

INV_ADCx	ADC Signal Polarity
0	Not Inverted
1	Inverted



### 6.11.5 ADC Mute

Configures a digital mute on ADC channel x.

ADCxMUTE	ADC Mute
0	Not Inverted
1	Inverted

## 6.12 Playback Control 1 (Address 0Dh)

7	6	5	4	3	2	1	0
HPGAIN2	HPGAIN1	HPGAIN0	PLYBCKB=A	INV_PCMB	INV_PCMA	MSTBMUTE	MSTAMUTE

### 6.12.1 Headphone Analog Gain

Selects the gain multiplier for the headphone/line outputs.

HPGAIN[2:0]	Headphone/Line Gain Setting (G)
000	0.3959
001	0.4571
010	0.5111
011	0.6047
100	0.7099
101	0.8399
110	1.000
111	1.1430

**Note:** Refer to “Line Output Voltage Level Characteristics” on page 18 and “Headphone Output Power Characteristics” on page 19.

### 6.12.2 Playback Volume Setting B=A

Configures independent or ganged volume control of all playback channels.

PLYBCKB=A	Single Volume Control for all Playback Channels
0	Disabled
1	Enabled

### 6.12.3 Invert PCM Signal Polarity

Configures the polarity of the digital input signal.

INV_PCMx	PCM Signal Polarity
0	Not Inverted
1	Inverted

### 6.12.4 Master Playback Mute

Configures a digital mute on the master volume control for channel x.

MSTxMUTE	Master Mute
0	Not Inverted
1	Inverted

**Note:** The muting function is affected by the DIGSFT (“Digital Soft Ramp” on page 53) and DIGZC (“Digital Zero Cross” on page 53) bits.

### 6.13 Miscellaneous Controls (Address 0Eh)

7	6	5	4	3	2	1	0
PASSTHRUB	PASSTHRUA	PASSBMUTE	PASSAMUTE	FREEZE	DEEMPH	DIGSFT	DIGZC

#### 6.13.1 Passthru Analog

Configures an analog passthru from the PGA inputs to the headphone/line outputs.

PASSTHRUx	Analog In Routed to HP/Line Output
0	Disabled
1	Enabled

**Notes:**

1. The Passthru volume control is realized using a combination of the PGA volume control settings (“PGAx Volume” on page 56) and the headphone amplifier volume control settings (hidden). When passthru is enabled and the PGA to ADC path is selected, the signal seen by the ADC will change depending on the passthru volume setting.

#### 6.13.2 Passthru Mute

Configures an analog mute on the channel x analog in to analog out passthru.

PASSxMUTE	Passthru Mute
0	Disabled
1	Enabled

#### 6.13.3 Freeze Registers

Configures a hold on all register settings.

FREEZE	Control Port Status
0	Register changes take effect immediately
1	Modifications may be made to all control port registers without the changes taking effect until after the FREEZE is disabled.

#### 6.13.4 HP/Speaker De-Emphasis

Configures a 15µs/50µs digital de-emphasis filter response on the headphone/line and speaker outputs.

DEEMPHASIS	Control Port Status
0	Disabled
1	Enabled

### 6.13.5 Digital Soft Ramp

Configures an incremental volume ramp from the current level to the new level at the specified rate.

DIGSFT	Volume Changes	Affected Digital Volume Controls
0	Do not occur on a zero crossing	MSTxMUTE (“Master Playback Mute” on page 51), HPxMUTE, SPKxMUTE (“Playback Control 2 (Address 0Fh)” on page 53), ADCxVOL[7:0] (“ADCx Volume” on page 57),
1	Occur on a zero crossing	AMIXxMUTE, AMIXxVOL[7:0] (“ADC Mixer Channel x Volume” on page 58), PMIXxMUTE, PMIXxVOL[7:0] (“PCM Mixer Channel x Volume” on page 58), MSTxVOL[7:0] (“Master Volume Control” on page 63), HPxVOL[7:0] (“Headphone Volume Control” on page 63), SPKxVOL[7:0] (“Speaker Volume Control” on page 64), ALC and Limiter Attack/Release (page 66 to page 68)
<b>Ramp Rate:</b>	1/8 dB every LRCK cycle	

### 6.13.6 Digital Zero Cross

Configures when the signal level changes occur for the digital volume controls.

DIGZC	Volume Changes	Affected Digital Volume Controls
0	Do not occur on a zero crossing	MSTxMUTE (“Master Playback Mute” on page 51), HPxMUTE, SPKxMUTE (“Playback Control 2 (Address 0Fh)” on page 53), ADCxVOL[7:0] (“ADCx Volume” on page 57),
1	Occur on a zero crossing	AMIXxMUTE, AMIXxVOL[7:0] (“ADC Mixer Channel x Volume” on page 58), PMIXxMUTE, PMIXxVOL[7:0] (“PCM Mixer Channel x Volume” on page 58), MSTxVOL[7:0] (“Master Volume Control” on page 63), HPxVOL[7:0] (“Headphone Volume Control” on page 63), SPKxVOL[7:0] (“Speaker Volume Control” on page 64), ALC and Limiter Attack/Release (page 66 to page 68)

**Notes:**

1. If the signal does not encounter a zero crossing, the requested volume change will occur after a timeout period between 1024 and 2048 sample periods (21.3 ms to 42.7 ms at 48 kHz sample rate).
2. The zero cross function is independently monitored and implemented for each channel.
3. The DIS\_LIMSFT bit (“Limiter Soft Ramp Disable” on page 65) is ignored when zero cross is enabled.

## 6.14 Playback Control 2 (Address 0Fh)

7	6	5	4	3	2	1	0
HPBMUTE	HPAMUTE	SPKBMUTE	SPKAMUTE	SPKB=A	SPKSWAP	SPKMONO	MUTE50/50

### 6.14.1 Headphone Mute

Configures a digital mute on headphone channel x.

HPxMUTE	Headphone Mute
0	Disabled
1	Enabled

### 6.14.2 Speaker Mute

Configures a digital mute on speaker channel x.

SPKxMUTE	Speaker Mute
0	Disabled
1	Enabled

### 6.14.3 Speaker Volume Setting B=A

Configures independent or ganged volume control of the speaker volume and mute.

SPKB=A	Single Volume Control for the Speaker Channel
0	Disabled
1	Enabled

### 6.14.4 Speaker Channel Swap

Configures a channel swap on the speaker channels.

SPKSWAP	Speaker Output
0	Channel A
1	Channel B
Application:	<a href="#">"Mono Speaker Output Configuration" on page 33</a>

### 6.14.5 Speaker MONO Control

Configures a parallel full bridge output for the speaker channels.

SPKMONO	Parallel Full Bridge Output
0	Disabled
1	Enabled
Application:	<a href="#">"Mono Speaker Output Configuration" on page 33</a>

### 6.14.6 Speaker Mute 50/50 Control

Configures how the speaker channels mute.

MUTE50/50	Speaker Mute 50/50
0	Disabled; The PWM amplifiers outputs modulated silence when SPKxMUTE is enabled.
1	Enabled; The PWM amplifiers switch at an exact 50%-duty-cycle signal (not modulated) when SPKxMUTE is enabled.

## 6.15 MICx Amp Control: MIC A (Address 10h) & MIC B (Address 11h)

7	6	5	4	3	2	1	0
Reserved	MICxSEL	MICxCFG	MICxGAIN4	MICxGAIN3	MICxGAIN2	MICxGAIN1	MICxGAIN0

### 6.15.1 MIC x Select

Selects one of two single-ended MIC inputs on channel x.

MICxSEL	MIC x Selection
0	MIC 1x
1	MIC 2x
Application:	<a href="#">"MIC Inputs" on page 27</a>

### 6.15.2 MICx Configuration

Configures the input topology for MICx.

MICxCFG	MIC Input Topology
0	Single-Ended
1	Differential
<b>Application:</b>	"MIC Inputs" on page 27

### 6.15.3 MICx Gain

Sets the gain of the microphone pre-amplifier.

MICxGAIN[4:0]	Gain
11111	32 dB
...	...
10000	32 dB
...	...
00000	16 dB
<b>Step Size:</b>	1 dB
<b>Application:</b>	"MIC Inputs" on page 27

## 6.16 PGAx Vol. & ALCx Transition Ctl.: ALC, PGA A (Address 12h) & ALC, PGA B (Address 13h)

7	6	5	4	3	2	1	0
ALCxSRDIS	ALCxZCDIS	PGAxVOL5	PGAxVOL4	PGAxVOL3	PGAxVOL2	PGAxVOL1	PGAxVOL0

### 6.16.1 ALCx Soft Ramp Disable

Configures an override of the analog soft ramp setting.

ALCxSRDIS	ALC Soft Ramp Disable
0	OFF; ALC Attack Rate is dictated by the ANLGSFT ("Ch. x Analog Soft Ramp" on page 49) setting
1	ON; ALC volume changes take effect in one step, regardless of the ANLGSFT setting.
<b>Application:</b>	"Automatic Level Control (ALC)" on page 27

### 6.16.2 ALCx Zero Cross Disable

Configures an override of the analog zero cross setting.

ALCxZCDIS	ALC Zero Cross Disable
0	OFF; ALC Attack Rate is dictated by the ANLGZC ("Ch. x Analog Zero Cross" on page 49) setting
1	ON; ALC volume changes take effect at any time, regardless of the ANLGZC setting.
<b>Application:</b>	"Automatic Level Control (ALC)" on page 27

### 6.16.3 PGAx Volume

Sets the volume/gain of the Programmable Gain Amplifier (PGA).

PGAxVOL[5:0]	Volume
01 1111	12 dB
...	...
01 1000	12 dB
...	...
00 0001	+0.5 dB
00 0000	0 dB
11 1111	-0.5 dB
...	...
10 1000	-6.0 dB
...	...
10 0000	-6.0 dB
<b>Step Size:</b>	0.5 dB

**Note:** The PGAxVOL bits are ignored when the PASSTHRUx bit ([“Passthru Analog” on page 52](#)) is enabled.

## 6.17 Passthru x Volume: PASSAVOL (Address 14h) & PASSBVOL (Address 15h)

7	6	5	4	3	2	1	0
PASSxVOL7	PASSxVOL6	PASSxVOL5	PASSxVOL4	PASSxVOL3	PASSxVOL2	PASSxVOL1	PASSxVOL0

### 6.17.1 Passthru x Volume

Sets the volume/gain of the signal routed from the PGA to the headphone/line output.

PASSxVOL[7:0]	Gain
0111 1111	12 dB
...	...
0001 1000	12 dB
...	...
0000 0001	+0.5 dB
0000 0000	0 dB
1111 1111	-0.5 dB
...	...
1000 1000	-60.0 dB
...	...
1000 0000	-60.0 dB
<b>Step Size:</b>	0.5 dB (approximate)
<b>Application:</b>	<a href="#">“Analog In to Analog Out Passthru” on page 32</a>

**Notes:**

1. This register is ignored when the PASSTHRUx bit ([“Passthru Analog” on page 52](#)) is disabled.
2. The step size may deviate from 0.5 dB at settings below -40 dB. Code settings 0x95, 0xA1, 0xAD and 0xB9 are not guaranteed to be monotonic.

**6.18 ADCx Volume Control: ADCAVOL (Address 16h) & ADCBVOL (Address 17h)**

7	6	5	4	3	2	1	0
ADCAVOL7	ADCAVOL6	ADCAVOL5	ADCAVOL4	ADCAVOL3	ADCAVOL2	ADCAVOL1	ADCAVOL0

**6.18.1 ADCx Volume**

Sets the volume of the ADC signal out the serial data output (SDOUT).

ADCxVOL[7:0]	Volume
0111 1111	24 dB
...	...
0001 1000	24 dB
...	...
0000 0000	0 dB
1111 1111	-1.0 dB
1111 1110	-2.0 dB
...	...
1010 0000	-96.0 dB
...	...
1000 0000	-96.0 dB
<b>Step Size:</b>	1.0 dB

## 6.19 ADCx Mixer Volume: ADCA (Address 18h) & ADCB (Address 19h)

7	6	5	4	3	2	1	0
AMIXxMUTE	AMIXxVOL6	AMIXxVOL5	AMIXxVOL4	AMIXxVOL3	AMIXxVOL2	AMIXxVOL1	AMIXxVOL0

### 6.19.1 ADC Mixer Channel x Mute

Configures a digital mute on the ADC mix in the DSP.

AMIXxMUTE	ADC Mixer Mute
0	Disabled
1	Enabled

### 6.19.2 ADC Mixer Channel x Volume

Sets the volume/gain of the ADC mix in the DSP.

AMIXxVOL[6:0]	Volume
001 1000	+12.0 dB
...	...
000 0001	+0.5 dB
000 0000	0 dB
111 1111	-0.5 dB
...	...
001 1001	-51.5 dB
<b>Step Size:</b>	0.5 dB

## 6.20 PCMx Mixer Volume: PCMA (Address 1Ah) & PCMB (Address 1Bh)

7	6	5	4	3	2	1	0
PMIXxMUTE	PMIXxVOL6	PMIXxVOL5	PMIXxVOL4	PMIXxVOL3	PMIXxVOL2	PMIXxVOL1	PMIXxVOL0

### 6.20.1 PCM Mixer Channel x Mute

Configures a digital mute on the PCM mix from the serial data input (SDIN) to the DSP.

PMIXxMUTE	PCM Mixer Mute
0	Disabled
1	Enabled

### 6.20.2 PCM Mixer Channel x Volume

Sets the volume/gain of the PCM mix from the serial data input (SDIN) to the DSP.

PMIXxVOL[6:0]	Volume
001 1000	+12.0 dB
...	...
000 0001	+0.5 dB
000 0000	0 dB
111 1111	-0.5 dB
...	...
001 1001	-51.5 dB
<b>Step Size:</b>	0.5 dB



## 6.21 Beep Frequency & On Time (Address 1Ch)

7	6	5	4	3	2	1	0
FREQ3	FREQ2	FREQ1	FREQ0	ONTIME3	ONTIME2	ONTIME1	ONTIME0

### 6.21.1 Beep Frequency

Sets the frequency of the beep signal.

FREQ[3:0]	Frequency ( $F_s = 12, 24, 48$ or $96$ kHz)	Pitch
0000	260.87 Hz	C4
0001	521.74 Hz	C5
0010	585.37 Hz	D5
0011	666.67 Hz	E5
0100	705.88 Hz	F5
0101	774.19 Hz	G5
0110	888.89 Hz	A5
0111	1000.00 Hz	B5
1000	1043.48 Hz	C6
1001	1200.00 Hz	D6
1010	1333.33 Hz	E6
1011	1411.76 Hz	F6
1100	1600.00 Hz	G6
1101	1714.29 Hz	A6
1110	2000.00 Hz	B6
1111	2181.82 Hz	C7
<b>Application:</b>	<a href="#">"Beep Generator" on page 30</a>	

#### Notes:

1. This setting must not change when BEEP is enabled.
2. Beep frequency will scale directly with sample rate,  $F_s$ , but is fixed at the nominal  $F_s$  within each speed mode.

### 6.21.2 Beep On Time

Sets the on duration of the beep signal.

ONTIME[3:0]	On Time ( $F_s = 12, 24, 48$ or $96$ kHz)
0000	~86 ms
0001	~430 ms
0010	~780 ms
0011	~1.20 s
0100	~1.50 s
0101	~1.80 s
0110	~2.20 s
0111	~2.50 s
1000	~2.80 s
1001	~3.20 s
1010	~3.50 s
1011	~3.80 s
1100	~4.20 s
1101	~4.50 s
1110	~4.80 s
1111	~5.20 s
<b>Application:</b>	<a href="#">"Beep Generator" on page 30</a>

**Notes:**

1. This setting must not change when BEEP is enabled.
2. Beep on time will scale inversely with sample rate,  $F_s$ , but is fixed at the nominal  $F_s$  within each speed mode.

### 6.22 Beep Volume & Off Time (Address 1Dh)

7	6	5	4	3	2	1	0
OFFTIME2	OFFTIME1	OFFTIME0	BPVOL4	BPVOL3	BPVOL2	BPVOL1	BPVOL0

#### 6.22.1 Beep Off Time

Sets the off duration of the beep signal.

OFFTIME[2:0]	Off Time ( $F_s = 48$ or $96$ kHz)
000	~1.23 s
001	~2.58 s
010	~3.90 s
011	~5.20 s
100	~6.60 s
101	~8.05 s
110	~9.35 s
111	~10.80 s
<b>Application:</b>	<a href="#">"Beep Generator" on page 30</a>

**Notes:**

1. This setting must not change when BEEP is enabled.
2. Beep off time will scale inversely with sample rate,  $F_s$ , but is fixed at the nominal  $F_s$  within each speed mode.

### 6.22.2 Beep Volume

Sets the volume of the beep signal.

BEEPVOL[4:0]	Gain
00110	+12.0 dB
...	...
00000	0 dB
11111	-2 dB
11110	-4 dB
...	...
00111	-50 dB
<b>Step Size:</b>	2 dB
<b>Application:</b>	<a href="#">"Beep Generator" on page 30</a>

**Note:** This setting must not change when BEEP is enabled.

## 6.23 Beep & Tone Configuration (Address 1Eh)

7	6	5	4	3	2	1	0
BEEP1	BEEP0	BEEPMIXDIS	TREBCF1	TREBCF0	BASSCF1	BASSCF0	TCEN

### 6.23.1 Beep Configuration

Configures a beep mixed with the HP/Line and SPK output.

BEEP[1:0]	Beep Occurrence
00	Off
01	Single
10	Multiple
11	Continuous
<b>Application:</b>	<a href="#">"Beep Generator" on page 30</a>

**Notes:**

1. When used in analog pass through mode, the output alternates between the signal from the PGA and the beep signal. The beep signal does not mix with the analog signal from the PGA.
2. Re-engaging the beep before it has completed its initial cycle will cause the beep signal to remain ON for the maximum ONTIME duration.

### 6.23.2 Beep Mix Disable

Configures how the beep mixes with the serial data input.

BEEPMIXDIS	Beep Output to HP/Line and Speaker
0	Mix Enabled; The beep signal mixes with the digital signal from the serial data input.
1	Mix Disabled; The output alternates between the signal from the serial data input and the beep signal. The beep signal does not mix with the digital signal from the serial data input.
<b>Application:</b>	<a href="#">"Beep Generator" on page 30</a>

**Note:** This setting must not change when BEEP is enabled.

### 6.23.3 Treble Corner Frequency

Sets the corner frequency (-3 dB point) for the treble shelving filter.

TREBCF[1:0]	Treble Corner Frequency Setting
00	5 kHz
01	7 kHz
10	10 kHz
11	15 kHz

### 6.23.4 Bass Corner Frequency

Sets the corner frequency (-3 dB point) for the bass shelving filter.

BASSCF[1:0]	Bass Corner Frequency Setting
00	50 Hz
01	100 Hz
10	200 Hz
11	250 Hz

### 6.23.5 Tone Control Enable

Configures the treble and bass activation.

TCEN	Bass and Treble Control
0	Disabled
1	Enabled
<b>Application:</b>	<a href="#">"Beep Generator" on page 30</a>

## 6.24 Tone Control (Address 1Fh)

7	6	5	4	3	2	1	0
TREB3	TREB2	TREB1	TREB0	BASS3	BASS2	BASS1	BASS0

### 6.24.1 Treble Gain

Sets the gain of the treble shelving filter.

TREB[3:0]	Gain Setting
0000	+12.0 dB
...	...
0111	+1.5 dB
1000	0 dB
1001	-1.5 dB
...	...
1111	-10.5 dB
<b>Step Size:</b>	1.5 dB

### 6.24.2 Bass Gain

Sets the gain of the bass shelving filter.

TREB[3:0]	Gain Setting
0000	+12.0 dB
...	...
0111	+1.5 dB
1000	0 dB
1001	-1.5 dB
...	...
1111	-10.5 dB
<b>Step Size:</b>	1.5 dB

### 6.25 Master Volume Control: MSTA (Address 20h) & MSTB (Address 21h)

7	6	5	4	3	2	1	0
MSTxVOL7	MSTxVOL6	MSTxVOL5	MSTxVOL4	MSTxVOL3	MSTxVOL2	MSTxVOL1	MSTxVOL0

#### 6.25.1 Master Volume Control

Sets the volume of the signal out the DSP.

MSTxVOL[7:0]	Master Volume
0001 1000	+12.0 dB
...	...
0000 0000	0 dB
1111 1111	-0.5 dB
1111 1110	-1.0 dB
...	...
0011 0100	-102 dB
...	...
0001 1001	-102 dB
<b>Step Size:</b>	0.5 dB

### 6.26 Headphone Volume Control: HPA (Address 22h) & HPB (Address 23h)

7	6	5	4	3	2	1	0
HPxVOL7	HPxVOL6	HPxVOL5	HPxVOL4	HPxVOL3	HPxVOL2	HPxVOL1	HPxVOL0

#### 6.26.1 Headphone Volume Control

Sets the volume of the signal out the DAC.

HPxVOL[7:0]	Headphone Volume
0000 0000	0 dB
1111 1111	-0.5 dB
1111 1110	-1.0 dB
...	...
0011 0100	-96.0 dB
...	...
0000 0001	Muted
<b>Step Size:</b>	0.5 dB

## 6.27 Speaker Volume Control: SPKA (Address 24h) & SPKB (Address 25h)

7	6	5	4	3	2	1	0
SPKxVOL7	SPKxVOL6	SPKxVOL5	SPKxVOL4	SPKxVOL3	SPKxVOL2	SPKxVOL1	SPKxVOL0

### 6.27.1 Speaker Volume Control

Sets the volume of the signal out the PWM modulator.

SPKxVOL[7:0]	Speaker Volume
0000 0000	0 dB
1111 1111	-0.5 dB
1111 1110	-1.0 dB
...	...
0100 0000	-96.0 dB
...	...
0000 0001	Muted
<b>Step Size:</b>	0.5 dB

## 6.28 ADC & PCM Channel Mixer (Address 26h)

7	6	5	4	3	2	1	0
PCMASWP1	PCMASWP0	PCMBSWP1	PCMBSWP0	ADCASWP1	ADCASWP0	ADCBSWP1	ADCBSWP0

### 6.28.1 PCM Mix Channel Swap

Configures a mix/swap of the PCM Mix to the headphone/line or speaker outputs.

PCMxSWP[1:0]	PCM Mix to HP/LINEOUTA	PCM Mix to HP/LINEOUTB
00	Left	Right
01	(Left + Right)/2	(Left + Right)/2
10		
11	Right	Left

### 6.28.2 ADC Mix Channel Swap

Configures a mix/swap of the ADC Mix to the headphone/line or speaker outputs.

ADCxSWP[1:0]	ADC Mix to HP/LINEOUTA Channel	ADC Mix to HP/LINEOUTB Channel
00	Left	Right
01	(Left + Right)/2	(Left + Right)/2
10		
11	Right	Left

## 6.29 Limiter Control 1, Min/Max Thresholds (Address 27h)

7	6	5	4	3	2	1	0
LMAX2	LMAX1	LMAX0	CUSH2	CUSH1	CUSH0	LIMSRDIS	LIMZCDIS

### 6.29.1 Limiter Maximum Threshold

Sets the maximum level, below full scale, at which to limit and attenuate the output signal at the attack rate (LIMARATE - [“Limiter Release Rate” on page 66](#)).

LMAX[2:0]	Threshold Setting
000	0 dB
001	-3 dB
010	-6 dB
011	-9 dB
100	-12 dB
101	-18 dB
110	-24 dB
111	-30 dB
<b>Application:</b>	<a href="#">“Limiter” on page 31</a>

**Note:** Bass, Treble and digital gain settings that boost the signal beyond the maximum threshold may trigger an attack.

### 6.29.2 Limiter Cushion Threshold

Sets the minimum level at which to disengage the Limiter’s attenuation at the release rate (LIMRRATE - [“Limiter Release Rate” on page 66](#)) until levels lie between the LMAX and CUSH thresholds.

CUSH[2:0]	Threshold Setting
000	0 dB
001	-3 dB
010	-6 dB
011	-9 dB
100	-12 dB
101	-18 dB
110	-24 dB
111	-30 dB
<b>Application:</b>	<a href="#">“Limiter” on page 31</a>

**Note:** This setting is usually set slightly below the LMAX threshold.

### 6.29.3 Limiter Soft Ramp Disable

Configures an override of the digital soft ramp setting.

LIMSRDIS	Limiter Soft Ramp Disable
0	OFF; Limiter Attack Rate is dictated by the DIGSFT ( <a href="#">“Digital Soft Ramp” on page 53</a> ) setting
1	ON; Limiter volume changes take effect in one step, regardless of the DIGSFT setting.
<b>Application:</b>	<a href="#">“Limiter” on page 31</a>

**Note:** This bit is ignored when the DIGZC ([“Digital Zero Cross” on page 53](#)) is enabled.

### 6.29.4 Limiter Zero Cross Disable

Configures an override of the digital zero cross setting.

LIMZCDIS	Limiter Zero Cross Disable
0	OFF; Limiter Attack Rate is dictated by the DIGZC ( <a href="#">“Digital Zero Cross” on page 53</a> ) setting
1	ON; Limiter volume changes take effect in one step, regardless of the DIGZC setting.
Application:	<a href="#">“Limiter” on page 31</a>

## 6.30 Limiter Control 2, Release Rate (Address 28h)

7	6	5	4	3	2	1	0
LIMIT	LIMIT_ALL	LIMRRATE5	LIMRRATE4	LIMRRATE3	LIMRRATE2	LIMRRATE1	LIMRRATE0

### 6.30.1 Peak Detect and Limiter

Configures the peak detect and limiter circuitry.

LIMIT	Limiter Status
0	Disabled
1	Enabled
Application:	<a href="#">“Limiter” on page 31</a>

### 6.30.2 Peak Signal Limit All Channels

Sets how channels are attenuated when the limiter is enabled.

LIMIT_ALL	Limiter action:
0	Apply the necessary attenuation on a specific channel only when the signal amplitude on <i>that</i> specific channel rises above LMAX. Remove attenuation on a specific channel only when the signal amplitude on <i>that</i> specific channel falls below CUSH.
1	Apply the necessary attenuation on BOTH channels when the signal amplitude on any ONE channel rises above LMAX. Remove attenuation on BOTH channels only when the signal amplitude on BOTH channels fall below CUSH.
Application:	<a href="#">“Limiter” on page 31</a>

### 6.30.3 Limiter Release Rate

Sets the rate at which the limiter releases the digital attenuation from levels below the CUSH[2:0] threshold ([“Limiter Cushion Threshold” on page 65](#)) and returns the analog output level to the MSTxVOL[7:0] ([“Master Volume Control” on page 63](#)) setting.

LIMRRATE[5:0]	Release Time
00 0000	Fastest Release
...	...
11 1111	Slowest Release
Application:	<a href="#">“Limiter” on page 31</a>

**Note:** The limiter release rate is user-selectable but is also a function of the sampling frequency,  $F_s$ , and the DIGSFT ([“Digital Soft Ramp” on page 53](#)) and DIGZC ([“Digital Zero Cross” on page 53](#)) setting.



### 6.31 Limiter Attack Rate (Address 29h)

7	6	5	4	3	2	1	0
Reserved	Reserved	LIMARATE5	LIMARATE4	LIMARATE3	LIMARATE2	LIMARATE1	LIMARATE0

#### 6.31.1 Limiter Attack Rate

Sets the rate at which the limiter applies digital attenuation from levels above the MAX[2:0] threshold (“Limiter Maximum Threshold” on page 65).

LIMARATE[5:0]	Attack Time
00 0000	Fastest Attack
...	...
11 1111	Slowest Attack
<b>Application:</b>	“Limiter” on page 31

**Note:** The limiter attack rate is user-selectable but is also a function of the sampling frequency, Fs, and the DIGSFT (“Digital Soft Ramp” on page 53) and DIGZC (“Digital Zero Cross” on page 53) setting unless the respective disable bit (“Limiter Soft Ramp Disable” on page 65 or “Limiter Zero Cross Disable” on page 66) is enabled.

### 6.32 ALC Enable & Attack Rate (Address 2Ah)

7	6	5	4	3	2	1	0
ALCB	ALCA	ALCARATE5	AALCRATE4	ALCARATE3	ALCARATE2	ALCARATE1	ALCARATE0

#### 6.32.1 ALCx Enable

Configures the automatic level controller.

ALC	ALC Status
0	Disabled
1	Enabled
<b>Application:</b>	“Automatic Level Control (ALC)” on page 27

#### 6.32.2 ALC Attack Rate

Sets the rate at which the ALC applies analog and/or digital attenuation from levels above the AMAX[2:0] threshold (“ALC Maximum Threshold” on page 68).

LIMARATE[5:0]	Attack Time
00 0000	Fastest Attack
...	...
11 1111	Slowest Attack
<b>Application:</b>	“Automatic Level Control (ALC)” on page 27

**Note:** The ALC attack rate is user-selectable but is also a function of the sampling frequency, Fs, and the ANLGSFTx (“Ch. x Analog Soft Ramp” on page 49) and ANLGZCx (“Ch. x Analog Zero Cross” on page 49) setting unless the respective disable bit (“ALCx Soft Ramp Disable” on page 55 or “ALCx Zero Cross Disable” on page 55) is enabled.

### 6.33 ALC Release Rate (Address 2Bh)

7	6	5	4	3	2	1	0
Reserved	Reserved	ALCRRATE5	ALCRRATE4	ALCRRATE3	ALCRRATE2	ALCRRATE1	ALCRRATE0

#### 6.33.1 ALC Release Rate

Sets the rate at which the ALC releases the analog and/or digital attenuation from levels below the MIN[2:0] threshold (“[ALC Minimum Threshold](#)” on page 69) and returns the signal level to the PGAX-VOL[5:0] (“[PGAx Volume](#)” on page 56) and ADCxVOL[7:0] (“[ADCx Volume](#)” on page 57) setting.

ALCRRATE[5:0]	Release Time
00 0000	Fastest Release
...	...
11 1111	Slowest Release
<b>Application:</b>	“ <a href="#">Automatic Level Control (ALC)</a> ” on page 27

**Notes:**

1. The ALC release rate is user-selectable but is also a function of the sampling frequency, Fs, and the ANLGSFTx (“[Ch. x Analog Soft Ramp](#)” on page 49) and ANLGZCx (“[Ch. x Analog Zero Cross](#)” on page 49) setting.
2. The Release Rate setting must always be slower than the Attack Rate.

### 6.34 ALC Threshold (Address 2Ch)

7	6	5	4	3	2	1	0
ALCMAx2	ALCMAx1	ALCMAx0	ALCMIx2	ALCMIx1	ALCMIx0	Reserved	Reserved

#### 6.34.1 ALC Maximum Threshold

Sets the maximum level, below full scale, at which to limit and attenuate the input signal at the attack rate (ALCARATE - “[ALC Attack Rate](#)” on page 67).

MAX[2:0]	Threshold Setting
000	0 dB
001	-3 dB
010	-6 dB
011	-9 dB
100	-12 dB
101	-18 dB
110	-24 dB
111	-30 dB
<b>Application:</b>	“ <a href="#">Automatic Level Control (ALC)</a> ” on page 27

### 6.34.2 ALC Minimum Threshold

Sets the minimum level at which to disengage the ALC's attenuation or amplify the input signal at the release rate (ALCRRATE - [“ALC Release Rate” on page 68](#)) until levels lie between the ALCMAX and ALCMIN thresholds.

ALCMIN[2:0]	Threshold Setting
000	0 dB
001	-3 dB
010	-6 dB
011	-9 dB
100	-12 dB
101	-18 dB
110	-24 dB
111	-30 dB
<b>Application:</b>	<a href="#">“Automatic Level Control (ALC)” on page 27</a>

**Note:** This setting is usually set slightly below the ALCMAX threshold.

### 6.35 Noise Gate Control (Address 2Dh)

7	6	5	4	3	2	1	0
NGALL	NG	NG_BOOST	THRESH2	THRESH1	THRESH0	NGDELAY1	NGDELAY0

#### 6.35.1 Noise Gate All Channels

Sets which channels are attenuated when clipping on any single channel occurs.

NGALL	Noise Gate triggered by:
0	Individual channel; Any channel that falls below the threshold setting triggers the noise gate attenuation for both channels.
1	Both channels A & B; Both channels must fall below the threshold setting for the noise gate attenuation to take effect.
<b>Application:</b>	<a href="#">“Noise Gate” on page 28</a>

#### 6.35.2 Noise Gate Enable

Configures the noise gate.

NG	Noise Gate Status
0	Disabled
1	Enabled
<b>Application:</b>	<a href="#">“Noise Gate” on page 28</a>

### 6.35.3 Noise Gate Threshold and Boost

THRESH sets the threshold level of the noise gate. Input signals below the threshold level will be attenuated to -96 dB. NG\_BOOST configures a +30 dB boost to the threshold settings.

THRESH[2:0]	Minimum Setting (NG_BOOST = '0'b)	Minimum Setting (NG_BOOST = '1'b)
000	-64 dB	-34 dB
001	-67 dB	-37 dB
010	-70 dB	-40 dB
011	-73 dB	-43 dB
100	-76 dB	-46 dB
101	-82 dB	-52 dB
110	Reserved	-58 dB
111	Reserved	-64 dB
<b>Application:</b>	<a href="#">"Noise Gate" on page 28</a>	

### 6.35.4 Noise Gate Delay Timing

Sets the delay time before the noise gate attacks.

NGDELAY[1:0]	Delay Setting
00	50 ms
01	100 ms
10	150 ms
11	200 ms
<b>Application:</b>	<a href="#">"Noise Gate" on page 28</a>

**Note:** The Noise Gate attack rate is a function of the sampling frequency,  $F_s$ , and the ANLGSFTx ("Ch. x Analog Soft Ramp" on page 49) and ANLGZCx ("Ch. x Analog Zero Cross" on page 49) setting unless the respective disable bit ("ALCx Soft Ramp Disable" on page 55 or "ALCx Zero Cross Disable" on page 55) is enabled.

## 6.36 Status (Address 2Eh) (Read Only)

For all bits in this register, a "1" means the associated error condition has occurred at least once since the register was last read. A "0" means the associated error condition has NOT occurred since the last reading of the register. Reading the register resets all bits to 0.

7	6	5	4	3	2	1	0
Reserved	SPCLKERR	DSPAOVFL	DSPBOVFL	PCMAOVFL	PCMBOVFL	ADCAOVFL	ADCBOVFL

### 6.36.1 Serial Port Clock Error (Read Only)

Indicates the status of the MCLK to LRCK ratio.

SPCLKERR	Serial Port Clock Status:
0	MCLK/LRCK ratio is valid.
1	MCLK/LRCK ratio is not valid.
<b>Application:</b>	<a href="#">"Serial Port Clocking" on page 34</a>

**Note:** On initial power up and application of clocks, this bit will report '1'b as the serial port re-synchronizes.

### 6.36.2 DSP Engine Overflow (Read Only)

Indicates the over-range status in the DSP data path.

<b>DSPxOVFL</b>	<b>DSP Overflow Status:</b>
0	No digital clipping has occurred in the data path after the DSP.
1	Digital clipping has occurred in the data path after the DSP.
<b>Application:</b>	<a href="#">"Analog Outputs" on page 29</a>

### 6.36.3 PCMx Overflow (Read Only)

Indicates the over-range status in the PCM mix data path.

<b>PCMxOVFL</b>	<b>PCM Overflow Status:</b>
0	No digital clipping has occurred in the data path of the PCM mix (" <a href="#">PCM Mixer Channel x Volume</a> " on page 58) of the DSP.
1	Digital clipping has occurred in the data path of the PCM mix of the DSP.
<b>Application:</b>	<a href="#">"Analog Outputs" on page 29</a>

### 6.36.4 ADCx Overflow (Read Only)

Indicates the over-range status in the ADC signal path.

<b>ADCxOVFL</b>	<b>ADC Overflow Status:</b>
0	No clipping has occurred anywhere in the ADC signal path.
1	Clipping has occurred in the ADC signal path.
<b>Application:</b>	<a href="#">"Analog Inputs" on page 26</a>

## 6.37 Battery Compensation (Address 2Fh)

7	6	5	4	3	2	1	0
BATTCMP	VPMONITOR	Reserved	Reserved	VPREF3	VPREF2	VPREF1	VPREF0

### 6.37.1 Battery Compensation

Configures automatic adjustment of the speaker volume when VP deviates from VPREF[3:0].

<b>BATTCMP</b>	<b>Automatic Battery Compensation</b>
0	Disabled
1	Enabled
<b>Application:</b>	<a href="#">"Maintaining a Desired Output Level" on page 34</a>

### 6.37.2 VP Monitor

Configures the internal ADC that monitors the VP voltage level.

<b>VPMONITOR</b>	<b>VP ADC Status</b>
0	Disabled
1	Enabled

**Note:** The internal ADC that monitors the VP supply is enabled automatically when BATTCMP is enabled, regardless of the VPMONITOR setting. Conversely, when BATTCMP is disabled, the ADC may be enabled by enabling VPMONITOR; this provides a convenient battery monitor without enabling battery compensation.

### 6.37.3 VP Reference

Sets the desired VP reference used for battery compensation.

VPREF[3:0]	Desired VP used to calculate the required attenuation on the speaker output: (for VA = 1.8 V)
0000	1.5 V
0001	2.0 V
0010	2.5 V
0011	3.0 V
0100	3.5 V
0101	4.0 V
0110	4.5 V
0111	5.0 V
(for VA = 2.5 V)	
1000	1.5 V
1001	2.0 V
1010	2.5 V
1011	3.0 V
1100	3.5 V
1101	4.0 V
1110	4.5 V
1111	5.0 V
<b>Application:</b>	"VP Battery Compensation" on page 33

### 6.38 VP Battery Level (Address 30h) (Read Only)

7	6	5	4	3	2	1	0
VPLVL7	VPLVL6	VPLVL5	VPLVL4	VPLVL3	VPLVL2	VPLVL1	VPLVL0

#### 6.38.1 VP Voltage Level (Read Only)

Indicates the unsigned VP voltage level.

VPLVL[7:0]	VP Voltage
...	
0101 1110	3.0 V (for VA = 2.0 V); apply formula using actual VA voltage to calculate VP voltage.
...	
0111 0010	3.7 V (for VA = 2.0 V); apply formula using actual VA voltage to calculate VP voltage.
...	
<b>Formula:</b>	$VP\ Voltage = (Binary\ representation\ of\ VPLVL[7:0]) * VA / 63.3$

### 6.39 Speaker Status (Address 31h) (Read Only)

7	6	5	4	3	2	1	0
Reserved	Reserved	SPKASHRT	SPKBSHRT	SPKR/HP	Reserved	TWRN	TERR

#### 6.39.1 Speaker Current Load Status (Read Only)

Indicates whether or not any of the speaker outputs is shorted to ground.

SPKxSHRT	Speaker Output Load
0	No overload detected
1	Overload detected

### 6.39.2 SPKR/HP Pin Status (Read Only)

Indicates the status of the SPKR/HP pin.

SPKR/HP	Pin State
0	Pulled Low
1	Pulled High

### 6.39.3 Thermal Warning Status (Read Only)

Indicates whether or not the CODEC's die temperature is approaching thermal error status.

TWRN	Thermal Status
0	Die temperature has not approached thermal error status.
1	Die temperature is approaching thermal error status.

### 6.39.4 Thermal Error Status (Read Only)

Indicates whether or not the CODEC's die temperature has exceeded safe temperatures.

TERR	Thermal Status
0	Die temperature is within safe operating limits
1	Die temperature has reached unsafe levels; Speaker outputs will shut down immediately.

## 6.40 Temperature Monitor Control (Address 32h)

7	6	5	4	3	2	1	0
RELEASE	Reserved	Reserved	Reserved	Reserved	Reserved	Reserved	Reserved

### 6.40.1 Temperature Acknowledge & Release

User-acknowledge input allowing the speaker output to resume normal operation after an automatic thermal-error-shutdown ([“Thermal Error Status \(Read Only\)”](#) on page 73).

RELEASE	User Action
0	Remove automatic speaker-shutdown after thermal error is acknowledged
1	Acknowledge thermal error

**Note:** When temperatures exceed the TERRTHR[2:0] and the speaker outputs power down, this bit must first be toggled from '0'b to '1'b and then back to '0'b before the speaker powers up and resumes normal operation.

### 6.40.2 Thermal Foldback (Address 33h)

7	6	5	4	3	2	1	0
Reserved	Reserved	Reserved	Reserved	THRFLD	SPKATTN2	SPKATTN1	SPKATTN0

### 6.40.3 Thermal Foldback

Configures automatic adjustment of the speaker volume when the die temperature is approaching thermal error status.

THRFLD	Automatic Speaker Attenuation
0	Disabled
1	Enabled

**Note:** If THRFLD is enabled and subsequently disabled when a thermal warning (indicated by TWRN) is in progress, future automatic attenuation (specified in SPKATTN) is disabled but the current automatic attenuation may remain for as long as ~512 ms before returning to the volume specified in SPKxVOL[7:0].

### 6.40.4 Speaker Attenuation

Sets the speaker attenuation level when die temperature is approaching thermal error status.

SPKATTN[2:0]	Attenuation Setting
000	0 dB
001	1 dB
010	2 dB
011	3 dB
100	4 dB
101	5 dB
110	6 dB
111	7 dB

**Note:** The output levels of the affected channel returns to the volume specified in SPKxVOL[7:0] (“Speaker Volume Control” on page 64) after ~512 ms.

### 6.41 Charge Pump Frequency (Address 34h)

7	6	5	4	3	2	1	0
CHGFREQ3	CHGFREQ2	CHGFREQ1	CHGFREQ0	Reserved	Reserved	Reserved	Reserved

#### 6.41.1 Charge Pump Frequency

Sets the charge pump frequency on FLYN and FLYP.

CHGFREQ[3:0]	N
0000	0
...	
0101	5
...	
1111	15
<b>Formula:</b>	<b>Frequency = (64xFs)/(N+2)</b>

**Note:** The headphone output THD+N performance may be affected.



## 7. ANALOG PERFORMANCE PLOTS

### 7.1 Headphone THD+N versus Output Power Plots

Test conditions (unless otherwise specified): Input test signal is a 997 Hz sine wave; measurement bandwidth is 10 Hz to 20 kHz;  $F_s = 48$  kHz.

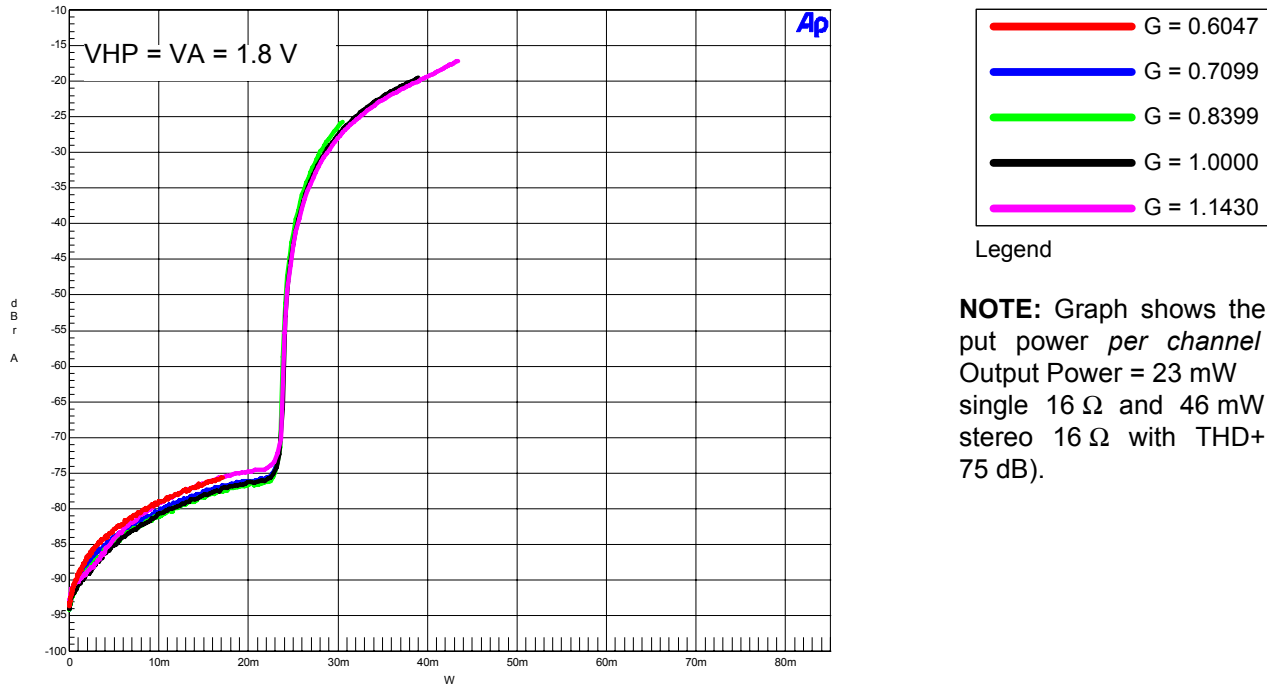

Figure 22. THD+N vs. Output Power per Channel at 1.8 V (16  $\Omega$  load)

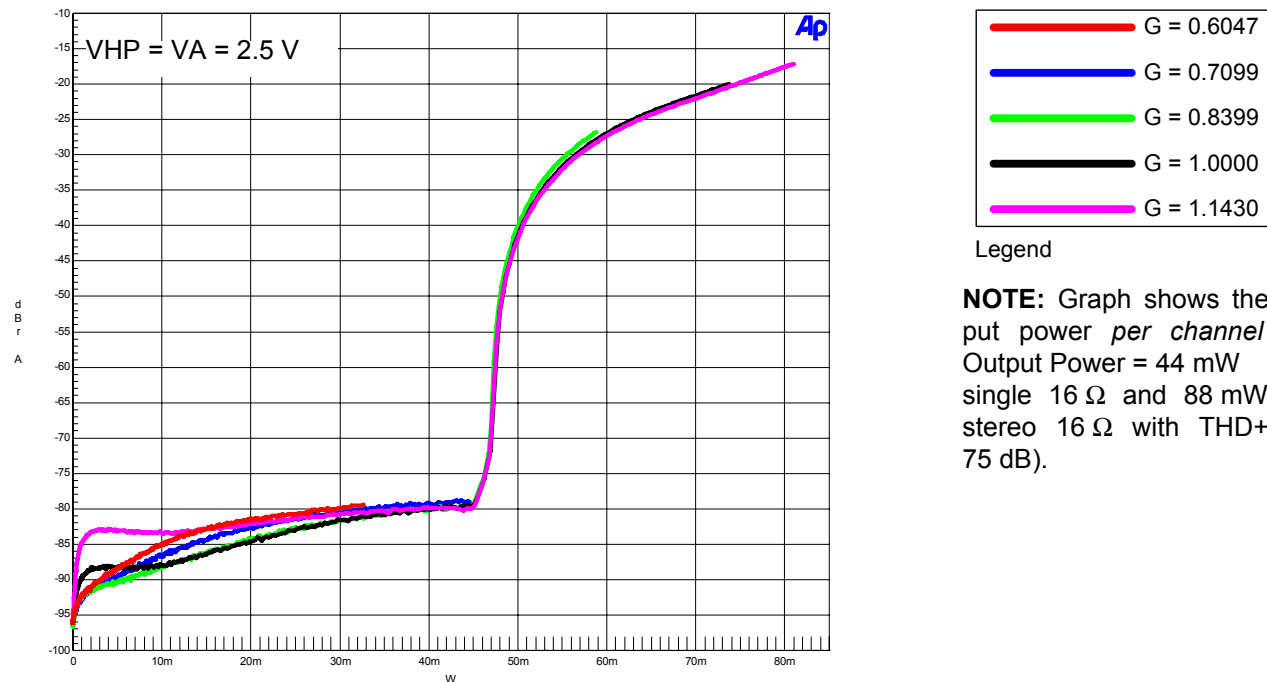
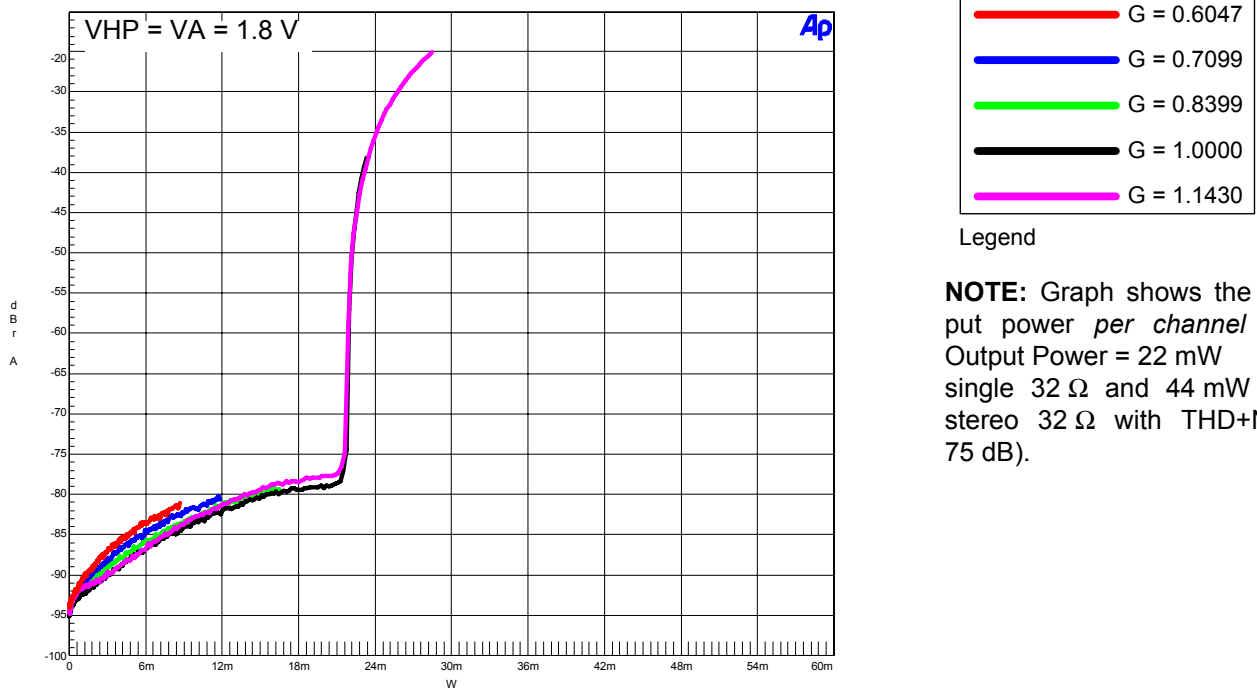
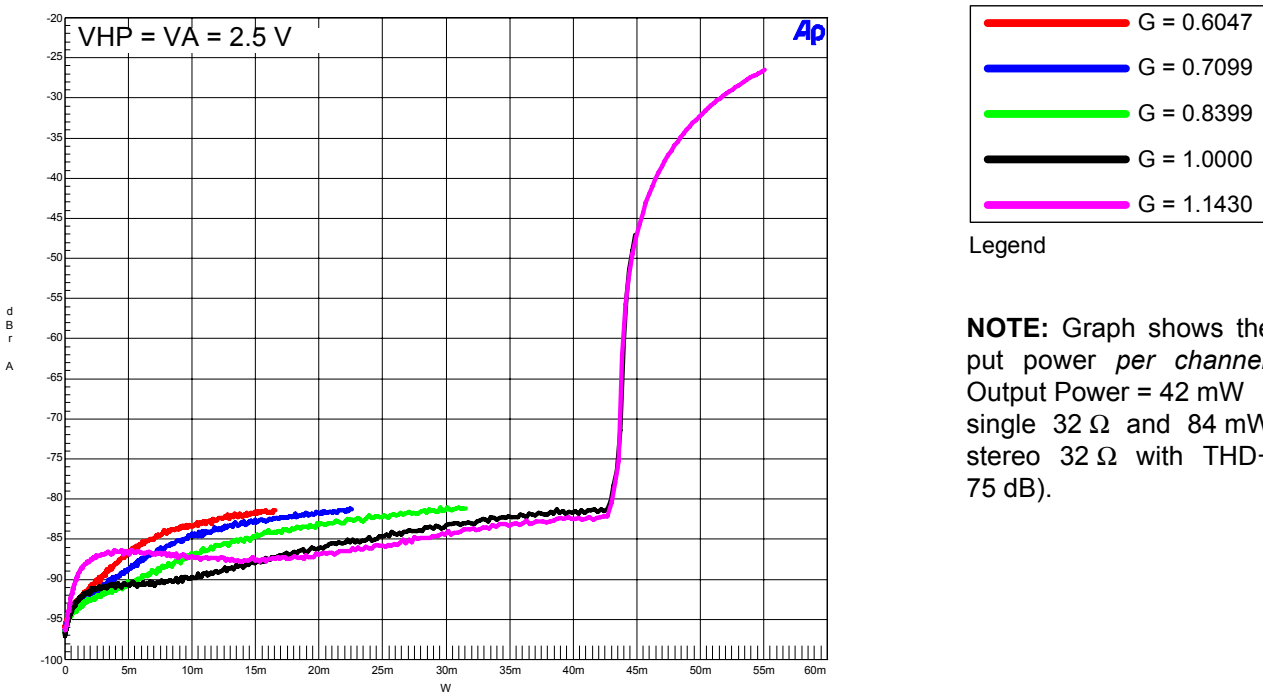

Figure 23. THD+N vs. Output Power per Channel at 2.5 V (16  $\Omega$  load)



**Figure 24. THD+N vs. Output Power per Channel at 1.8 V (32 Ω load)**



**Figure 25. THD+N vs. Output Power per Channel at 2.5 V (32 Ω load)**

**8. EXAMPLE SYSTEM CLOCK FREQUENCIES** \*The "MCLKDIV2" bit must be enabled.

**8.1 Auto Detect Enabled**

Sample Rate LRCK (kHz)	MCLK (MHz)			
	1024x	1536x	2048x*	3072x*
8	8.1920	12.2880	16.3840	24.5760
11.025	11.2896	16.9344	22.5792	33.8688
12	12.2880	18.4320	24.5760	36.8640

Sample Rate LRCK (kHz)	MCLK (MHz)			
	512x	768x	1024x*	1536x*
16	8.1920	12.2880	16.3840	24.5760
22.05	11.2896	16.9344	22.5792	33.8688
24	12.2880	18.4320	24.5760	36.8640

Sample Rate LRCK (kHz)	MCLK (MHz)			
	256x	384x	512x*	768x*
32	8.1920	12.2880	16.3840	24.5760
44.1	11.2896	16.9344	22.5792	33.8688
48	12.2880	18.4320	24.5760	36.8640

Sample Rate LRCK (kHz)	MCLK (MHz)			
	128x	192x	256x*	384x*
64	8.1920	12.2880	16.3840	24.5760
88.2	11.2896	16.9344	22.5792	33.8688
96	12.2880	18.4320	24.5760	36.8640

**8.2 Auto Detect Disabled**

Sample Rate LRCK (kHz)	MCLK (MHz)					
	512x	768x	1024x	1536x	2048x	3072x
8	-	6.1440	8.1920	12.2880	16.3840	24.5760
11.025	-	8.4672	11.2896	16.9344	22.5792	33.8688
12	6.1440	9.2160	12.2880	18.4320	24.5760	36.8640

Sample Rate LRCK (kHz)	MCLK (MHz)					
	256x	384x	512x	768x	1024x	1536x
16	-	6.1440	8.1920	12.2880	16.3840	24.5760
22.05	-	8.4672	11.2896	16.9344	22.5792	33.8688
24	6.1440	9.2160	12.2880	18.4320	24.5760	36.8640

Sample Rate LRCK (kHz)	MCLK (MHz)			
	256x	384x	512x	768x
32	8.1920	12.2880	16.3840	24.5760
44.1	11.2896	16.9344	22.5792	33.8688
48	12.2880	18.4320	24.5760	36.8640

Sample Rate LRCK (kHz)	MCLK (MHz)			
	128x	192x	256x	384x
64	8.1920	12.2880	16.3840	24.5760
88.2	11.2896	16.9344	22.5792	33.8688
96	12.2880	18.4320	24.5760	36.8640

---

## 9. PCB LAYOUT CONSIDERATIONS

### 9.1 Power Supply, Grounding

As with any high-resolution converter, the CS42L52 requires careful attention to power supply and grounding arrangements if its potential performance is to be realized. [Figure 1 on page 10](#) shows the recommended power arrangements, with VA and VHP connected to clean supplies VD, which powers the digital circuitry, may be run from the system logic supply. Alternatively, VD may be powered from the analog supply via a ferrite bead. In this case, no additional devices should be powered from VD.

Extensive use of power and ground planes, ground plane fill in unused areas and surface mount decoupling capacitors are recommended. Decoupling capacitors should be as close to the pins of the CS42L52 as possible. The low value ceramic capacitor should be closest to the pin and should be mounted on the same side of the board as the CS42L52 to minimize inductance effects.

All signals, especially clocks, should be kept away from the FILT+ and VQ pins in order to avoid unwanted coupling into the modulators. The FILT+ and VQ decoupling capacitors, particularly the 0.1  $\mu\text{F}$ , must be positioned to minimize the electrical path from FILT+ and AGND. The CDB42L52 evaluation board demonstrates the optimum layout and power supply arrangements.

### 9.2 QFN Thermal Pad

The CS42L52 is available in a compact QFN package. The underside of the QFN package reveals a large metal pad that serves as a thermal relief to provide for maximum heat dissipation. This pad must mate with an equally dimensioned copper pad on the PCB and must be electrically connected to ground. A series of vias should be used to connect this copper pad to one or more larger ground planes on other PCB layers. In split ground systems, it is recommended that this thermal pad be connected to AGND for best performance. The CS42L52 evaluation board demonstrates the optimum thermal pad and via configuration.

# 10.ADC & DAC DIGITAL FILTERS

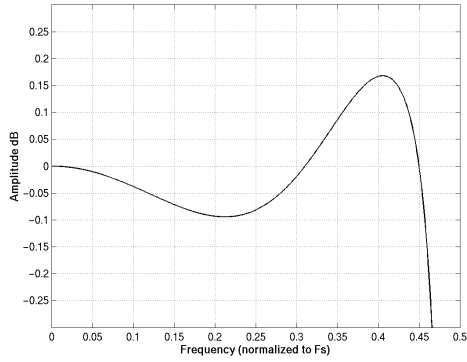

**Figure 26. ADC Passband Ripple**

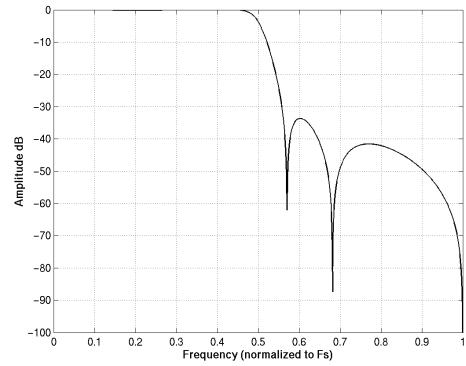

**Figure 27. ADC Stopband Rejection**

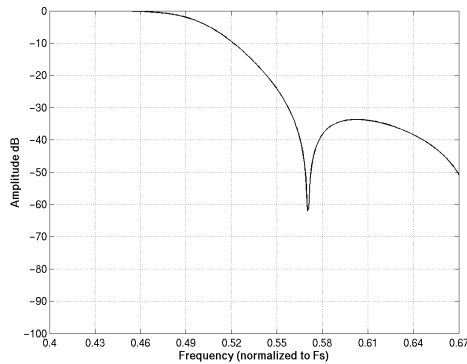

**Figure 28. ADC Transition Band**

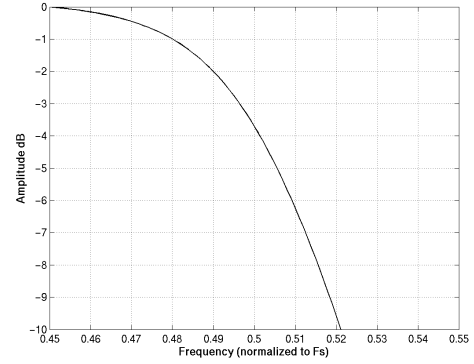

**Figure 29. ADC Transition Band Detail**

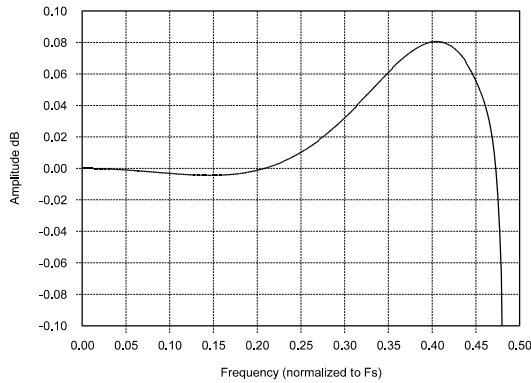

**Figure 30. DAC Passband Ripple**

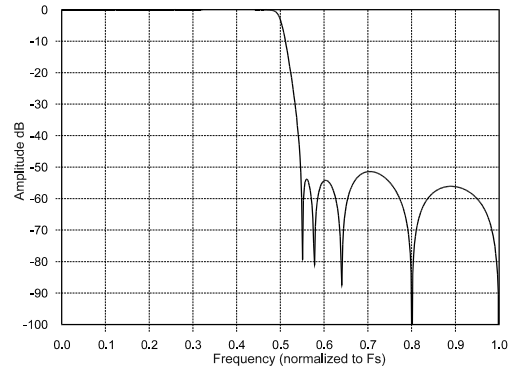

**Figure 31. DAC Stopband**

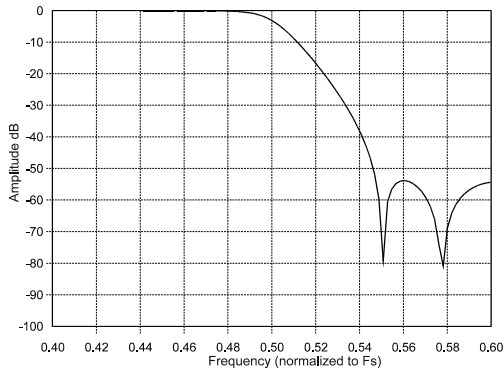

**Figure 32. DAC Transition Band**

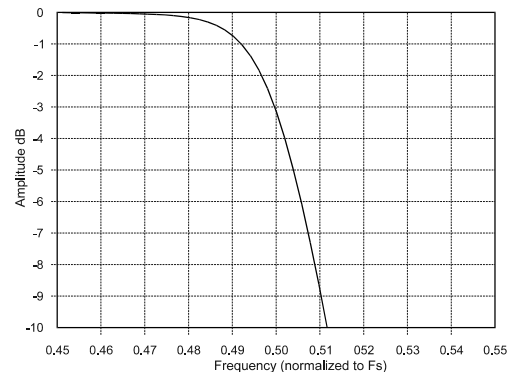

**Figure 33. DAC Transition Band (Detail)**

---

## 11. PARAMETER DEFINITIONS

### Dynamic Range

The ratio of the rms value of the signal to the rms sum of all other spectral components over the specified bandwidth. Dynamic Range is a signal-to-noise ratio measurement over the specified band width made with a -60 dBFS signal. 60 dB is added to resulting measurement to refer the measurement to full-scale. This technique ensures that the distortion components are below the noise level and do not affect the measurement. This measurement technique has been accepted by the Audio Engineering Society, AES17-1991, and the Electronic Industries Association of Japan, EIAJ CP-307. Expressed in decibels.

### Total Harmonic Distortion + Noise

The ratio of the rms value of the signal to the rms sum of all other spectral components over the specified band width (typically 10 Hz to 20 kHz), including distortion components. Expressed in decibels. Measured at -1 and -20 dBFS as suggested in AES17-1991 Annex A.

### Frequency Response

A measure of the amplitude response variation from 10 Hz to 20 kHz relative to the amplitude response at 1 kHz. Units in decibels.

### Interchannel Isolation

A measure of crosstalk between the left and right channel pairs. Measured for each channel at the converter's output with no signal to the input under test and a full-scale signal applied to the other channel. Units in decibels.

### Interchannel Gain Mismatch

The gain difference between left and right channel pairs. Units in decibels.

### Gain Error

The deviation from the nominal full-scale analog output for a full-scale digital input.

### Gain Drift

The change in gain value with temperature. Units in ppm/°C.

### Offset Error

The deviation of the mid-scale transition (111...111 to 000...000) from the ideal. Units in mV.

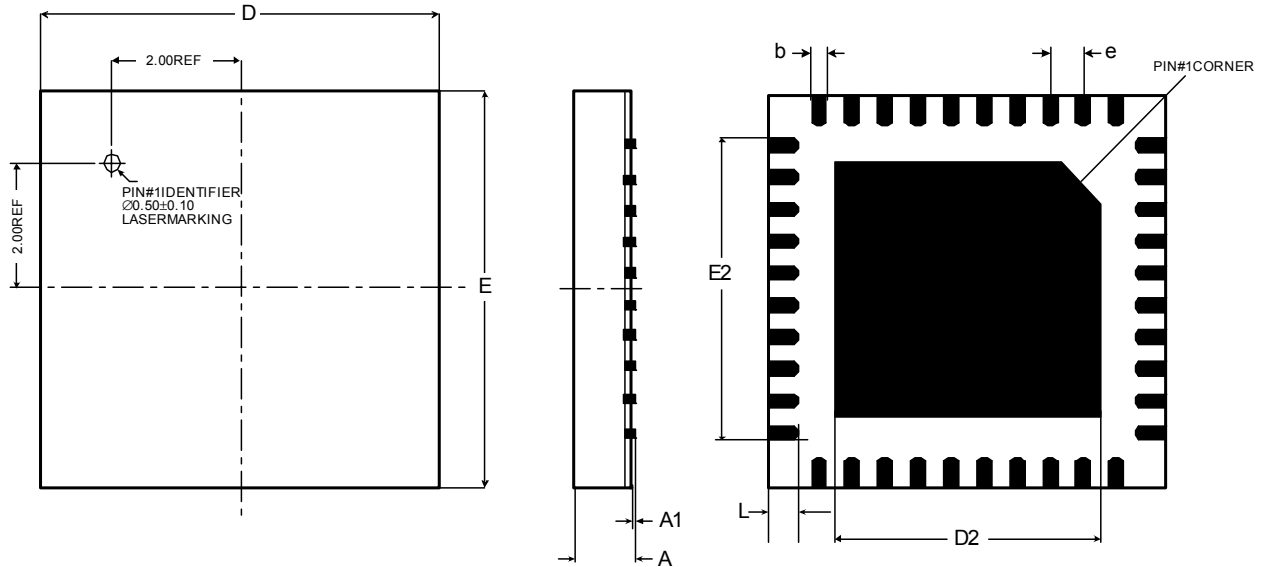
**12.PACKAGE DIMENSIONS**
**40L QFN (6 X 6 mm BODY) PACKAGE DRAWING**

DIM	INCHES			MILLIMETERS			NOTE
	MIN	NOM	MAX	MIN	NOM	MAX	
A	--	--	0.0394	--	--	1.00	1
A1	0.0000	--	0.0020	0.00	--	0.05	1
b	0.0071	0.0091	0.0110	0.18	0.23	0.28	1,2
D	0.2362 BSC			6.00 BSC			1
D2	0.1594	0.1614	0.1634	4.05	4.10	4.15	1
E	0.2362 BSC			6.00 BSC			1
E2	0.1594	0.1614	0.1634	4.05	4.10	4.15	1
e	0.0197 BSC			0.50 BSC			1
L	0.0118	0.0157	0.0197	0.30	0.40	0.50	1

**JEDEC #: MO-220**
*Controlling Dimension is Millimeters.*

1. Dimensioning and tolerance per ASME Y 14.5M-1995.
2. Dimensioning lead width applies to the plated terminal and is measured between 0.20 mm and 0.25 mm from the terminal tip.

**THERMAL CHARACTERISTICS**

Parameter		Symbol	Min	Typ	Max	Units
Junction to Ambient Thermal Impedance	2 Layer Board	$\theta_{JA}$	-	44	-	°C/Watt
	4 Layer Board		-	19	-	

## 13. ORDERING INFORMATION

Product	Description	Package	Pb-Free	Grade	Temp Range	Container	Order #
CS42L52	Low-Power Stereo CODEC w/HP and Speaker Amps for Portable Apps	40L-QFN	Yes	Commercial	-40 to +85° C	Rail	CS42L52-CNZ
						Tape & Reel	CS42L52-CNZR
				Automotive	-40 to +105° C	Rail	CS42L52-DNZ
						Tape & Reel	CS42L52-DNZR
CDB42L52	CS42L52 Evaluation Board	-	No	-	-	-	CDB42L52
CRD42L52	CS42L52 Reference Design	-	No	-	-	-	CRD42L52

## 14. REFERENCES

1. Philips Semiconductor, *The I<sup>2</sup>C-Bus Specification: Version 2.1*, January 2000.  
<http://www.semiconductors.philips.com>

## 15. REVISION HISTORY

Revision	Changes
A1	Initial Release

## Contacting Cirrus Logic Support

For all product questions and inquiries, contact a Cirrus Logic Sales Representative. To find one nearest you, go to [www.cirrus.com](http://www.cirrus.com).

### IMPORTANT NOTICE

"Advance" product information describes products that are in development and subject to development changes. Cirrus Logic, Inc. and its subsidiaries ("Cirrus") believe that the information contained in this document is accurate and reliable. However, the information is subject to change without notice and is provided "AS IS" without warranty of any kind (express or implied). Customers are advised to obtain the latest version of relevant information to verify, before placing orders, that information being relied on is current and complete. All products are sold subject to the terms and conditions of sale supplied at the time of order acknowledgment, including those pertaining to warranty, indemnification, and limitation of liability. No responsibility is assumed by Cirrus for the use of this information, including use of this information as the basis for manufacture or sale of any items, or for infringement of patents or other rights of third parties. This document is the property of Cirrus and by furnishing this information, Cirrus grants no license, express or implied under any patents, mask work rights, copyrights, trademarks, trade secrets or other intellectual property rights. Cirrus owns the copyrights associated with the information contained herein and gives consent for copies to be made of the information only for use within your organization with respect to Cirrus integrated circuits or other products of Cirrus. This consent does not extend to other copying such as copying for general distribution, advertising or promotional purposes, or for creating any work for resale.

CERTAIN APPLICATIONS USING SEMICONDUCTOR PRODUCTS MAY INVOLVE POTENTIAL RISKS OF DEATH, PERSONAL INJURY, OR SEVERE PROPERTY OR ENVIRONMENTAL DAMAGE ("CRITICAL APPLICATIONS"). CIRRUS PRODUCTS ARE NOT DESIGNED, AUTHORIZED OR WARRANTED FOR USE IN AIRCRAFT SYSTEMS, MILITARY APPLICATIONS, PRODUCTS SURGICALLY IMPLANTED INTO THE BODY, AUTOMOTIVE SAFETY OR SECURITY DEVICES, LIFE SUPPORT PRODUCTS OR OTHER CRITICAL APPLICATIONS. INCLUSION OF CIRRUS PRODUCTS IN SUCH APPLICATIONS IS UNDERSTOOD TO BE FULLY AT THE CUSTOMER'S RISK AND CIRRUS DISCLAIMS AND MAKES NO WARRANTY, EXPRESS, STATUTORY OR IMPLIED, INCLUDING THE IMPLIED WARRANTIES OF MERCHANTABILITY AND FITNESS FOR PARTICULAR PURPOSE, WITH REGARD TO ANY CIRRUS PRODUCT THAT IS USED IN SUCH A MANNER. IF THE CUSTOMER OR CUSTOMER'S CUSTOMER USES OR PERMITS THE USE OF CIRRUS PRODUCTS IN CRITICAL APPLICATIONS, CUSTOMER AGREES, BY SUCH USE, TO FULLY INDEMNIFY CIRRUS, ITS OFFICERS, DIRECTORS, EMPLOYEES, DISTRIBUTORS AND OTHER AGENTS FROM ANY AND ALL LIABILITY, INCLUDING ATTORNEYS' FEES AND COSTS, THAT MAY RESULT FROM OR ARISE IN CONNECTION WITH THESE USES.

Cirrus Logic, Cirrus, and the Cirrus Logic logo designs are trademarks of Cirrus Logic, Inc. All other brand and product names in this document may be trademarks or service marks of their respective owners.

I<sup>2</sup>C is a registered trademark of Philips Semiconductor.