

### GENERAL DESCRIPTION

CRE6559 combines a dedicated current mode PWM controller with a high voltage power MOSFET. It is optimized for high performance, low standby power, and cost effective off-line flyback converter applications in sub 30W range.

CRE6559 offers complete protection coverage with automatic self-recovery feature including Cycle-by-Cycle current limiting (OCP), over load protection (OLP), VDD over voltage clamp and under voltage lockout (UVLO). Excellent EMI performance is achieved with proprietary frequency shuffling technique together with soft switching control at the totem pole gate drive output.

The tone energy at below 20KHZ is minimized in the design and audio noise is eliminated during operation. CRE6559 is offered in DIP-8 package.

### APPLICATIONS

Offline AC/DC flyback converter for

- Battery Charger
- PDA power supplies
- Digital Cameras and Camcorder Adaptor
- VCR, SVR, STB, DVD&DVCD Player SM
- Set-Top Box Power
- Auxiliary Power Supply for PC and Server
- Open-frame SM

### FEATURES

- Power on Soft Start Reducing MOSFET VDS Stress
- Frequency shuffling for EMI
- Extended Burst Mode Control For Improved Efficiency and Minimum Standby Power Design
- Audio Noise Free Operation
- Fixed 65KHz Switching Frequency
- Internal Synchronized Slope Compensation
- Low VDD Startup Current and Low Operating Current
- Leading Edge Blanking on Current Sense Input
  - ▶ VDD Over Voltage Clamp and Under Voltage Lockout with Hysteresis (UVLO)
  - ▶ Line Input Compensated Cycle-by-Cycle Over-current Threshold Setting For Constant Output Power Limiting Over Universal Input Voltage Range
  - ▶ Overload Protection (OLP)
  - ▶ Over voltage Protection (OVP)
- Pb-Free DIP-8L

### TYPICAL APPLICATION

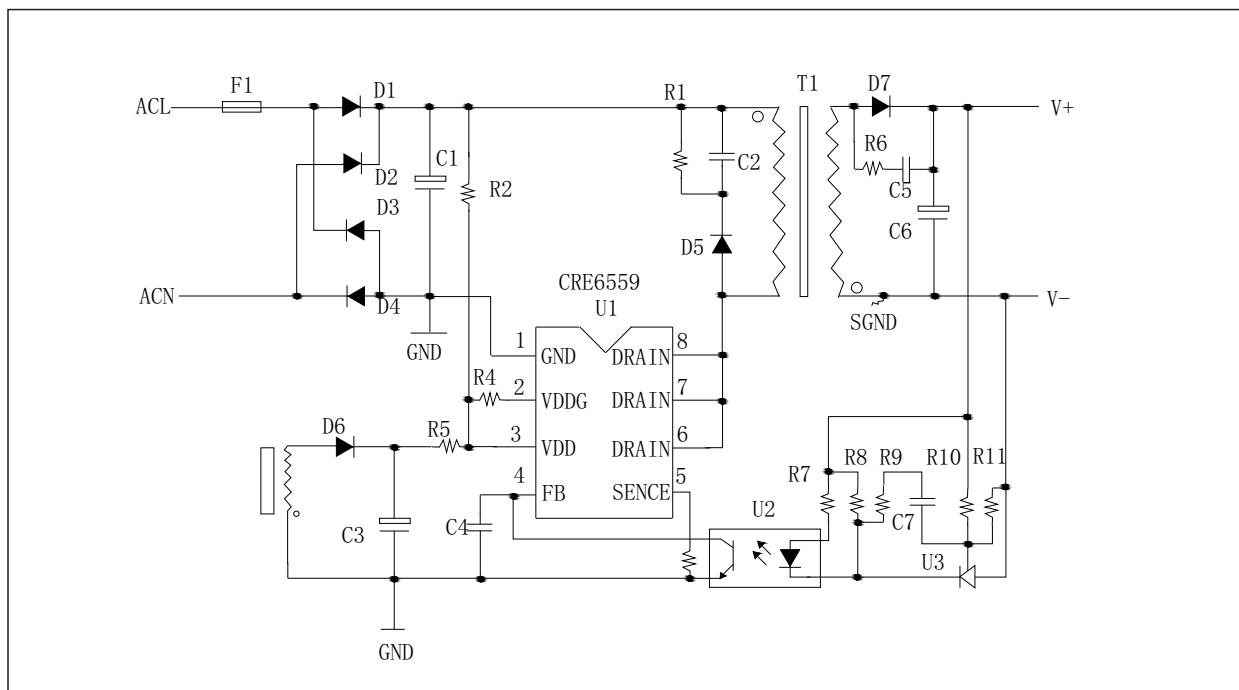

**GENERAL INFORMATION**

**Pin Configuration**

The CRE6559 is offered in DIP8 package as shown below.

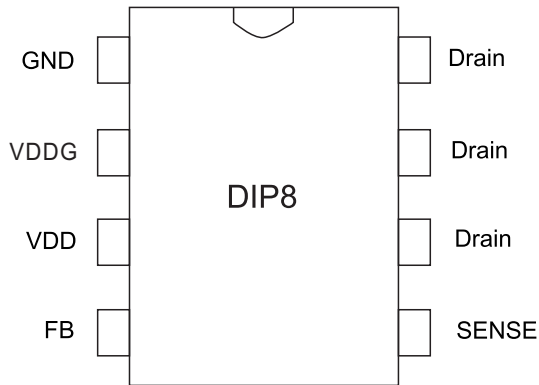

**Absolute Maximum Ratings**

Parameter	Value
Drain Voltage (off state)	-0.3V to 600V
VDD Voltage	-0.3V to 30V
VDD-G Input Voltage	-0.3V to 30V
VDD Clamp Continuous Current	10mA
FB Input Voltage	-0.3V to 7V
Sense Input Voltage	-0.3V to 7V
Min/Max Operating Junction Temperature T <sub>J</sub>	-20 °C to 150 °C
Min/Max Storage Temperature T <sub>stg</sub>	-55 °C to 160 °C
Lead Temperature (Soldering, 10secs)	260 °C

**TERMINAL ASSIGNMENTS**

Pin Name	I/O	Description
GND	O	Ground
FB	I	Feedback input pin. The PWM duty cycle is determined by voltage level into this pin and the current-sense signal at Pin 4.
VDD-G	I	Internal Gate Driver Power Supply
SENSE	I	Current sense input
VDD	I	IC DC power supply Input
Drain	O	HV MOSFET Drain Pin. The Drain pin is connected to the primary lead of the transformer

**MARKING INFORMATION**

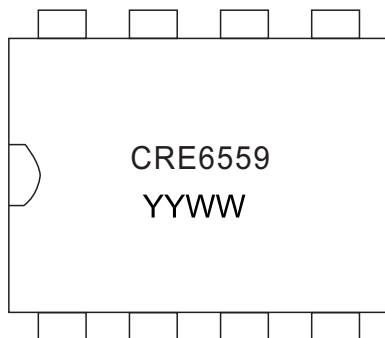

CRE6559:Product Name  
YY: Year Code (0~9)  
WW: Week Code (01~52)

OUTPUT POWER TABLE

Product	230VAC ± 15%	85-264VAC	Package
	Open Frame	Close Frame	
CRE6559	30W	24W	DIP8

Notes:

1. Maximum practical continuous power in an open frame design with sufficient drain pattern as a heat sink, at 50°C ambient.

BLOCK DIAGRAM

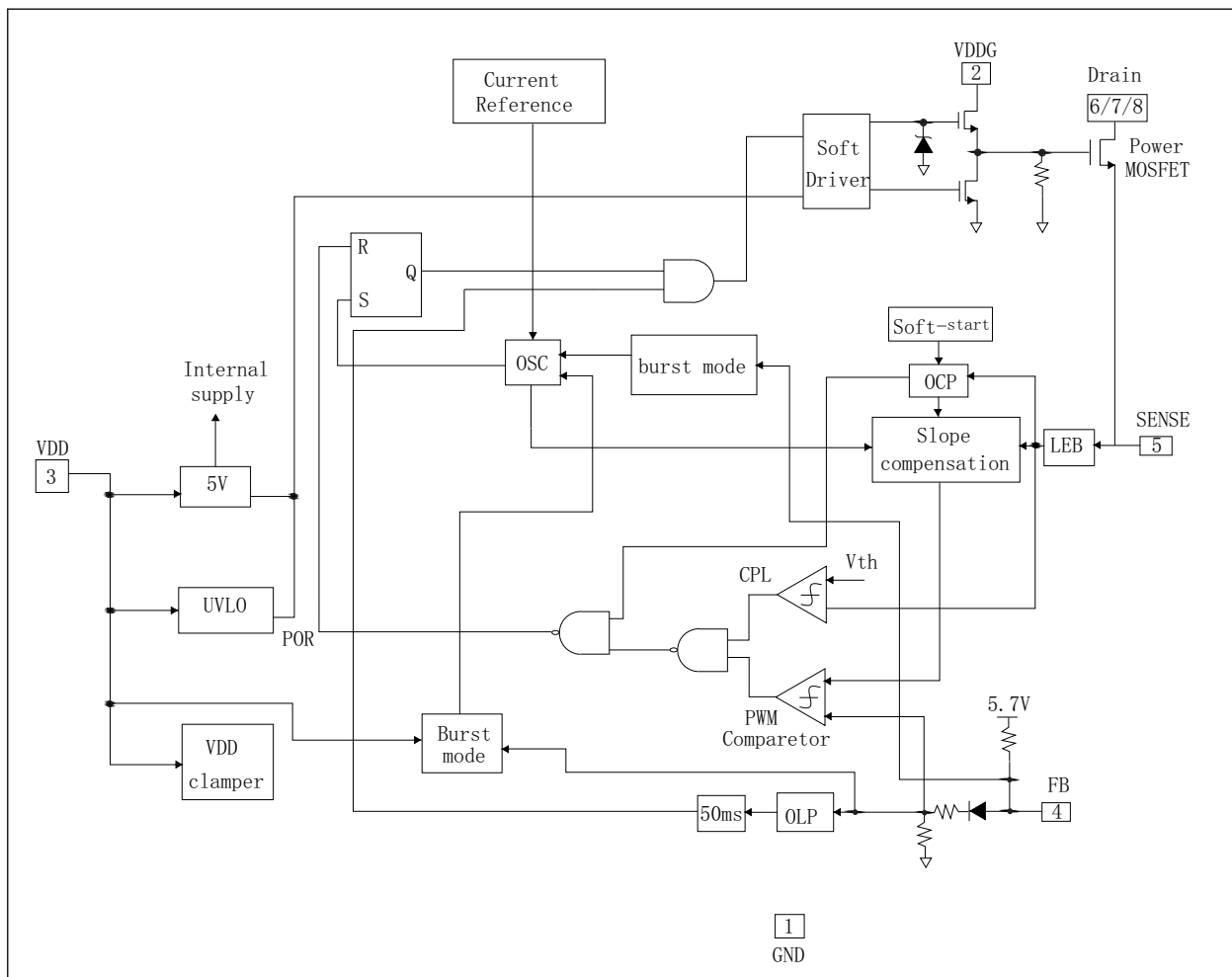

### ELECTRICAL CHARACTERISTICS

(TA = 25°C, VDD=VDDG=16V, if not otherwise noted)

Symbol	Parameter	Test Conditions	Min	Type	Max	Unit
Supply Voltage (VDD)						
I_start up	VDD Start up Current	VDD=14.5V, Measure Leakage current into VDD		6	20	u A
I_VDD Operation	Operation Current	V <sub>FB</sub> =3V		2.1		m A
UVLO(ON)	VDD Under Voltage Lockout Enter		8.7	9.3	10.7	V
UVLO(OFF)	VDD Under Voltage Lockout Exit		14.8	15.3	16.0	V
OVP(ON)	Over Voltage protection Voltage	CS=0V, FB=3V Ramp up VDD until gate clock is off	25.0	27.5	30	V
VDD_Clamp	VDD Zener Clamp Voltage	I <sub>DD</sub> =10mA		30		V
Feedback Input Section (FB Pin)						
V <sub>FB_</sub> Open	V <sub>FB</sub> Open Loop Voltage		5.4	5.6	6.0	V
I <sub>FB_</sub> Short	FB pin short circuit current	Short FB pin to GND and measure current		1.45		m A
V <sub>TH_</sub> 0D	Zero Duty Cycle FB Threshold Voltage			1.23		V
V <sub>TH_</sub> PL	Power Limiting FB Threshold Voltage			4.2		V
T <sub>D_</sub> PL	Power Limiting FB Debounce Time			50		ms
Z <sub>FB_</sub> IN	Input Impedance			4		Kohm
Current Sense Input (Sense Pin)						
Soft start time				4		ms
T_ blanking	Leading edge blanking time			270		ns
Z <sub>SENSE_</sub> IN	Input Impedance			40		Kohm
T <sub>D_</sub> OC	Over Current Detection and Control Delay	From Over Current occurs till the Gate drive output start to turn off		120		ns
V <sub>TH_</sub> OC	Internal Current Limiting Threshold Voltage	FB=3.3V	0.78	0.83	0.88	V
Oscillator						

Fosc	Normal Oscillation Frequency		60	65	70	KHz
$\Delta f_{Temp}$	Frequency Temperature Stability			5		%
$\Delta f_{VDD}$	Frequency Voltage Stability			5		%
D_max	Maximum duty cycle	FB=3.3V,CS=0V	70	80	90	%
F_Burst	Burst Mode Base Frequency			22		KHz
Power MOSFET Section						
BV-DSS	MOSFET Drain-Source Breakdown Voltage		600			V
ID	Drain Current Continuous			5.0		A
Rds-ON	Static Drain to Source On Resistance			2.0		$\Omega$
Frequency						
$\Delta f_{VDD}$	Frequency Modulation range/Base frequency		-4		4	%

**CHARACTERIZATION PLOTS**

(The characteristic graphs are normalized at Ta=25°C)

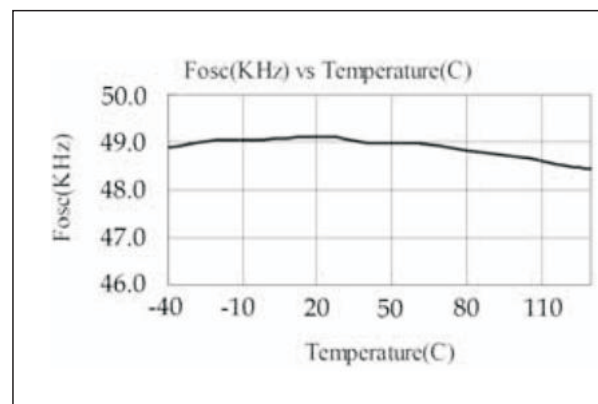
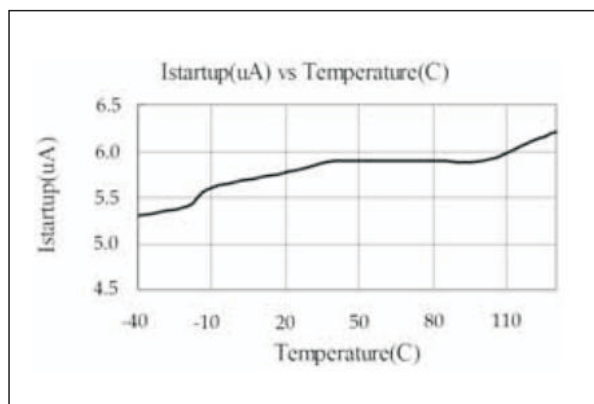
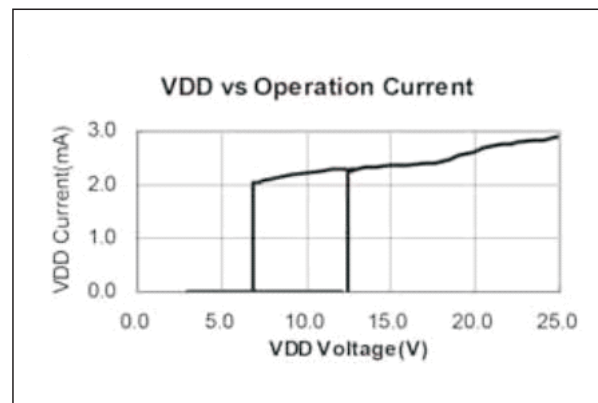
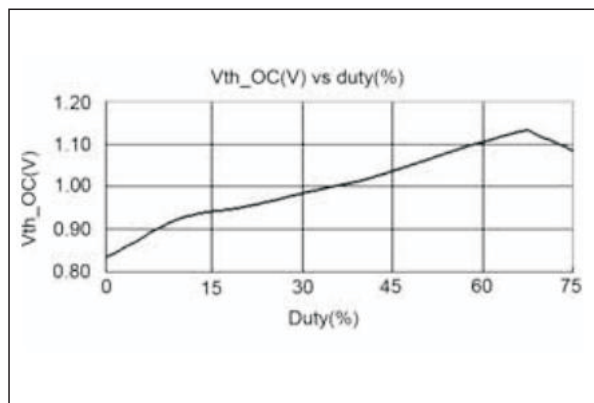
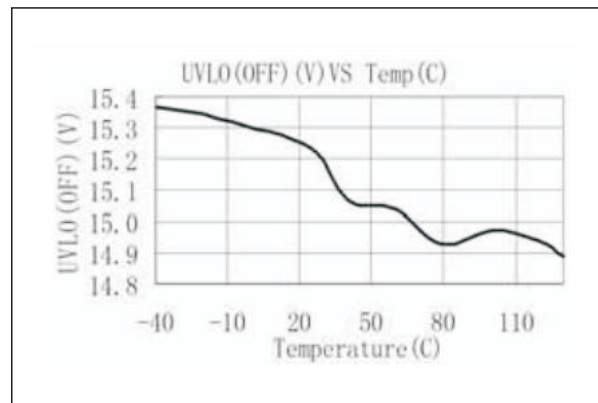
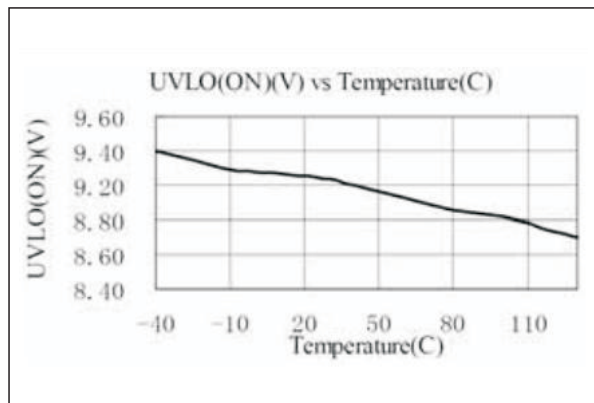

## OPERATION DESCRIPTION

The CRE6559 is a low power off-line PWM Switcher optimized for off-line fly back converter applications in sub 30W power range. The "Extended burst mode" control greatly reduces the standby power consumption and help the design easily to meet the international power conservation requirements.

### ■ Startup Current and Start up Control

Startup current of CRE6559 is designed to be very low so that VDD could be charged up above UVLO threshold level and device starts up quickly. A large value startup resistor can therefore be used to minimize the power loss yet achieve a reliable startup in application. For AC/DC adaptor with universal input range design, a 2M $\Omega$ , 1/8W startup resistor could be used together with a VDD capacitor to provide a fast startup and yet low power dissipation design solution.

### ■ Operating Current

The Operating current of CRE6559 is low at 2mA. Good efficiency is achieved with CRE6559 low operating current together with the "Extended burst mode" control features.

### ■ Soft Start

CRE6359 features an internal 4ms soft start to soften the electrical stress occurring in the power supply during startup. It is activated during the power on sequence. As soon as VDD reaches UVLO(OFF), the peak current is gradually increased from nearly zero to the maximum level of 0.83V. Every restart up is followed by a soft start.

### ■ Frequency shuffling for EMI improvement

The frequency Shuffling (switching frequency modulation) is implemented in CRE6559. The oscillation frequency is modulated so that the tone energy is spread out.. The spread spectrum minimizes the conduction band EMI and therefore eases the system design.

### ■ Extended Burst Mode Operation

At light load or zero load condition, most of the power dissipation in a switching mode power supply is from switching loss on the mosfet, the core loss of the ransformer and the loss on the snubber circuit. The magnitude of power loss is in proportion to the switching frequency. Lower switching frequency leads to the reduction on the power loss and thus conserves the energy. The switching frequency is internally adjusted at no load or light load condition.

The switch frequency reduces at light/no load condition to improve the conversion efficiency. At light load or no load condition, the FB input drop below burst mode threshold level and device enters Burst Mode control.

The Gate drive output switches only when VDD voltage drop below a preset level and FB input is active to output an on state. Otherwise the gate drive remains at off state to minimize the switching loss and reduces the standby power consumption to the greatest extend. The switching frequency control also eliminates the audio noise at any loading conditions.

### ■ Oscillator Operation

The switching frequency of CRE6559 is internally fixed at 65KHZ. No external frequency setting components are required for PCB design simplification

### ■ Current Sensing and Leading Edge Blanking

Cycle-by-Cycle current limiting is offered in CRE6559 current mode PWM control. The switch current is detected by a sense resistor into the sense pin. An internal leading edge blanking circuit chops off the sensed voltage spike at initial internal power MOSFET on state due to snubber diode reverse recovery and surge gate current of internal power MOSFET so that the external RC filtering on sense input is no longer needed. The current li comparator is disabled and cannot turn off the blanking period. The PWM duty cycle is determined by the current sense input voltage and the FB input

## OPERATION DESCRIPTION

voltage. .

### ■ Internal Synchronized Slope Compensation

Built-in slope compensation circuit adds voltage ramp onto the current sense input voltage for PWM generation. This greatly improves the close loop stability at CCM and prevents the sub-harmonic oscillation and thus reduces the output ripple voltage.

### ■ Drive

The internal power MOSFET in CRE6559 is driven by a dedicated gate driver for power switch control. Too weak the gate drive strength results in higher conduction and switch loss of MOSFET while too strong gate drive results the compromise of EMI. A good tradeoff is achieved through the built-in totem pole gate design with right output strength and dead time control. The low idle loss and good EMI system design is easier to achieve with this dedicated control scheme. In addition to the gate drive control scheme mentioned, the gate drive strength can also be adjusted externally by a resistor connected between VDD and VDDG, the falling edge of the Drain output can be well controlled. It provides great flexibility for system EMI design.

### ■ Protection Controls

Good power supply system reliability is achieved with its rich protection features including Cycle-by-Cycle current limiting(OCP),Over Load Protection(OLP)and over voltage clamp, UnderVoltage Lockout onVDD(UVLO). With Proprietary technology, the OCP is line voltage range. At overload condition when FB input voltage exceeds power limit threshold value for more than TD\_PL, control circuit reacts to shut down the switcher. Switcher restarts when VDD voltage drop below UVLO limit. VDD is supplied by transformer auxiliary winding output. It is clamped when VDD is higher than 30V .The output of CRE6559 is shut down when VDD drop below UVLO\_ON limit and Switcher enters power on start-up sequence.



PACKAGE MECHANICAL DATA

8-Pin Plastic DIP

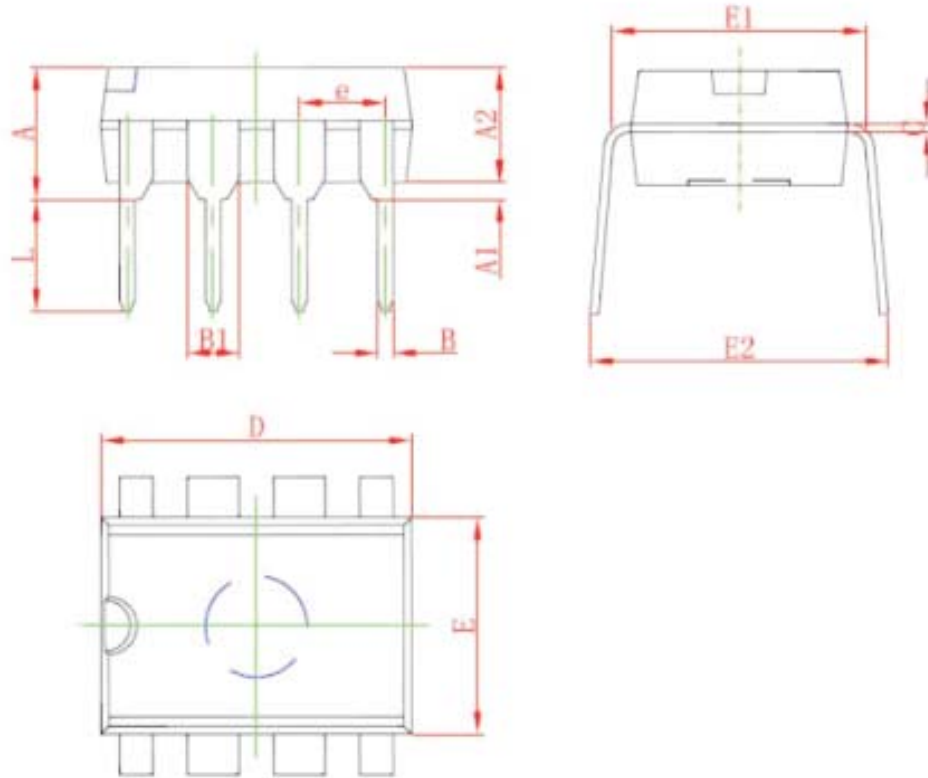

Symbol	Dimensions In Millimeters		Dimensions In Inches	
	Min	Max	Min	Max
A	3.710	4.310	0.148	0.170
A1	0.510		0.020	
A2	3.200	3.600	0.126	0.142
B	0.380	0.570	0.015	0.022
B1	1.524(BSC)		0.060(BSC)	
C	0.204	0.360	0.008	0.014
D	9.000	9.400	0.3540	0.370
E	6.200	6.600	0.2440	0.260
E1	7.320	7.920	0.288	0.312
e	2.540(BSC)		0.100(BSC)	
L	3.000	3.600	0.118	0.142
E2	8.400	9.000	0.331	0.354