

CRH02

Technical Datasheet

Analogue Angular Rate Sensor

High Performance MEMS Gyroscope

SILICON SENSING

www.siliconsensing.com



Features

- Proven and Robust silicon MEMS VSG3Q^{MAX} vibrating ring structure
- Four rate ranges available: $\pm 25^\circ/\text{s}$, $\pm 100^\circ/\text{s}$, $\pm 200^\circ/\text{s}$ and $\pm 400^\circ/\text{s}$
- FOG - like performance
- Low Bias Instability - $0.12^\circ/\text{hr}$ ($100^\circ/\text{s}$)
- Excellent Angle Random Walk - $0.017^\circ/\sqrt{\text{hr}}$
- Low noise - $0.15^\circ/\text{s}$ rms (50Hz bandwidth)
- Precision analogue output
- High shock and vibration rejection
- Wide range from -40°C to $+85^\circ\text{C}$
- Temperature sensor output for precision thermal compensation
- MEMS frequency output for precision thermal compensation
- RoHS Compliant

Applications

- Aerospace Applications
- Platform Stabilization
- Precision Surveying
- Maritime Guidance and Control
- Gyro-compassing and Heading Control
- Autonomous Vehicles and ROVs
- Rail Track monitoring
- Robotics
- Drilling Equipment and Guidance
- Inertial Measurement Units

1 General Description

CRH02 provides the optimum solution for applications where bias instability, angle random walk and low noise are of critical importance.

At the heart of the CRH02 is Silicon Sensing's VSG3Q^{MAX} vibrating ring MEMS sensor which is at the pinnacle of 15 years of design evolution and the latest off a line which has produced over 30 million high integrity MEMS inertial sensors. The VSG3Q^{MAX} gyro sensor is combined with precision discrete electronics to achieve high stability and low noise, making the CRH02 a viable alternative to Fibre-Optic Gyro (FOG) and Dynamically Tuned Gyro (DTG).

An on board temperature sensor and the resonant frequency of the MEMS enables additional external conditioning to be applied to the CRH02 by the host, enhancing the performance even further.

Typical applications include downhole surveying, drilling equipment, precision platform stabilization, ship stabilisation, ship guidance and control, autonomous vehicles, high-end AHRS and other flight instruments.

Whatever your application, the unique and patented silicon ring technology gives advanced and stable performance over time and temperature, overcoming mount sensitivity problems associated with simple beam or tuning fork based sensors.

© Copyright 2015 Silicon Sensing Systems Limited. All rights reserved. Silicon Sensing is an Atlantic Inertial Systems, Sumitomo Precision Products joint venture company. Specification subject to change without notice.

CRH02-00-0100-132 Rev 1

Page 1



Supporting your great ideas

www.pewatron.com

PEWATRON
a member of the Angst + Pfister Group

CRH02 Technical Datasheet

Analogue Angular Rate Sensor
High Performance MEMS Gyroscope

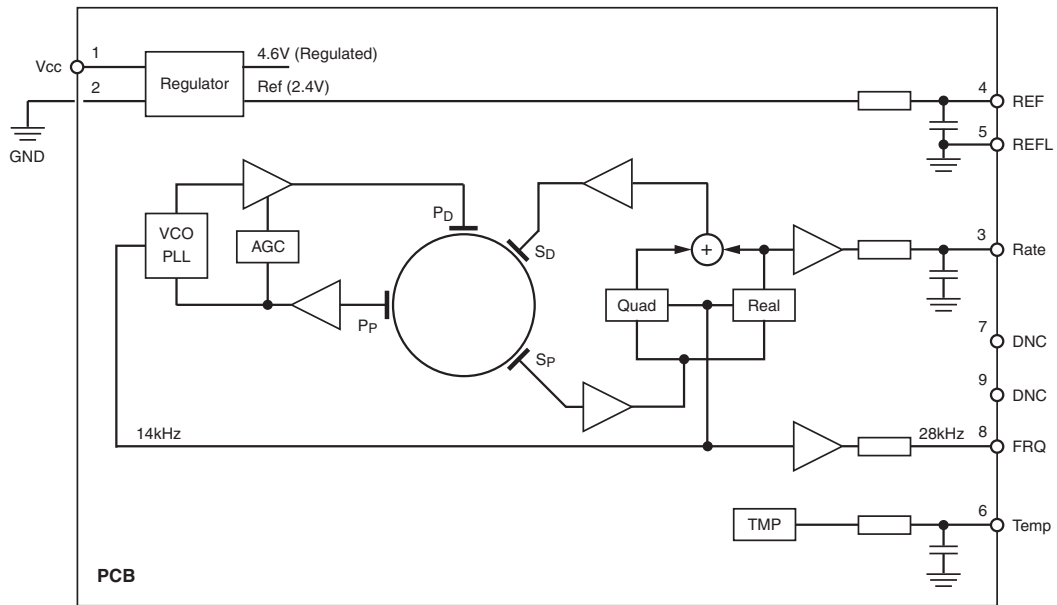

C.G. 18667

Figure 1.1 CRH02 Functional Block Diagram

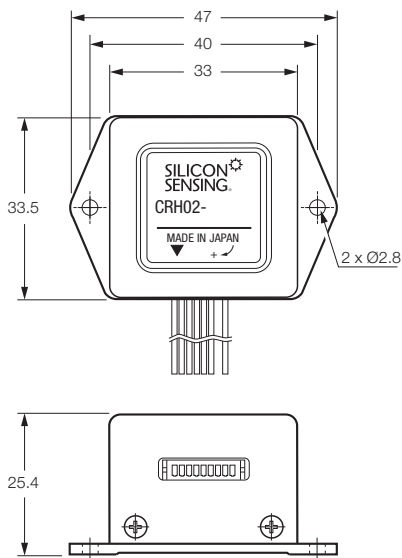

All dimensions in millimetres.

Figure 1.2 CRH02 Overall Dimensions

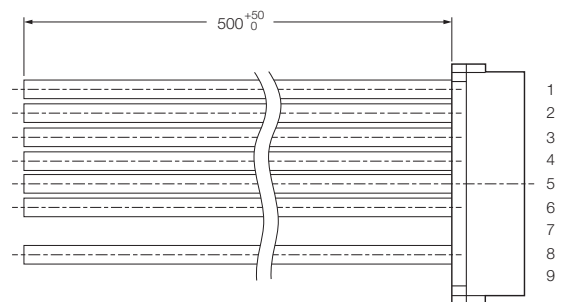

Figure 1.3 Mating Cable Assembly

© Copyright 2015 Silicon Sensing Systems Limited. All rights reserved. Silicon Sensing is an Atlantic Inertial Systems, Sumitomo Precision Products joint venture company. Specification subject to change without notice.

CRH02

Technical Datasheet

Analogue Angular Rate Sensor

High Performance MEMS Gyroscope

**SILICON
SENSING** 

www.siliconsensing.com

2 Ordering Information

Part Number	Rate Range
CRH02-025	±25°/s
CRH02-100	±100°/s
CRH02-200	±200°/s
CRH02-400	±400°/s

3 Specification

Unless otherwise specified the following specification values assume $V_{dd} = 4.85$ to $5.25V$ and an ambient temperature of $+25^{\circ}C$. "Over temperature" refers to the temperature range $-40^{\circ}C$ to $+85^{\circ}C$.

Parameter		Minimum	Typical	Maximum	Notes
Characteristic					
Rate Range	CRH02-025	±25°/s			–
	CRH02-100	±100°/s			–
	CRH02-200	±200°/s			–
	CRH02-400	±400°/s			–
Scale Factor at 25°C	CRH02-025	79.6mV/°/s	80.0mV/°/s	80.4mV/°/s	–
	CRH02-100	19.9mV/°/s	20.0mV/°/s	20.1mV/°/s	–
	CRH02-200	9.95mV/°/s	10.0mV/°/s	10.05mV/°/s	–
	CRH02-400	4.975mV/°/s	5.00mV/°/s	5.025mV/°/s	–
Scale Factor Variation Over Temperature with respect to 25°C value	CRH02-025	-0.5%	±0.15%	+0.5%	–
	CRH02-100				
	CRH02-200	-0.5%	±0.3%	+0.5%	–
	CRH02-400				
Scale Factor Non-Linearity	CRH02-025	-0.05%	±0.02%	+0.05%	–
	CRH02-100				
	CRH02-200				
	CRH02-400				
Bias at 25°C with respect to REF	CRH02	-10mV	–	+10mV	–
Bias Over Temperature with respect to RT (25°C)	CRH02-025	-0.2°/s	±0.1°/s	+0.2°/s	–
	CRH02-100				
	CRH02-200	-0.25°/s	±0.15°/s	+0.25°/s	–
	CRH02-400				

© Copyright 2015 Silicon Sensing Systems Limited. All rights reserved. Silicon Sensing is an Atlantic Inertial Systems, Sumitomo Precision Products joint venture company. Specification subject to change without notice.

CRH02-00-0100-132 Rev 1

Page 3



Supporting your great ideas

www.pewatron.com

PEWATRON
a member of the Angst + Pfister Group

CRH02

Technical Datasheet

Analogue Angular Rate Sensor

High Performance MEMS Gyroscope

SILICON SENSING

www.siliconsensing.com

3 Specification Continued

Parameter		Minimum	Typical	Maximum	Notes
Characteristic					
Angular Random Walk	CRH02-025	-	0.017°/√hr	-	As measured using the Allan Variance method (Note 1)
	CRH02-100				
	CRH02-200				
	CRH02-400				
Bias Instability	CRH02-025	-	0.12°/hr	-	As measured using the Allan Variance method (Note 2)
	CRH02-100				
	CRH02-200				
	CRH02-400				
Quiescent Noise	CRH02-025	-	0.15°/s rms	-	3~100Hz
	CRH02-100	-	0.20°/s rms	-	3~100Hz
	CRH02-200	-	0.20°/s rms	-	3~100Hz
	CRH02-400	-	0.15°/s rms	-	3~100Hz
Bandwidth	CRH02-025	-	50Hz	-	-
	CRH02-100	-	100Hz	-	-
	CRH02-200	-	100Hz	-	-
	CRH02-400	-	50Hz	-	-
Reference Output		2.380V	2.400V	2.420V	With respect to REFL output impedance 510ohm
Start Up Time		-	-	750ms	-
Physical					
Mass		-	45gram	-	-
Cross Axis Sensitivity		-	-	3%	-
Environmental					
Temperature (Operating)		-40°C	-	85°C	-
Temperature (Storage)		-40°C	-	85°C	-
Humidity		-	-	95%	Non-condensing
Linear Acceleration Sensitivity		-	0.02°/s/g	-	-
Shock (Operating)		-	-	95g x 6ms	½ sine
Shock (Powered Survival)		-	-	1,000g x 1ms	½ sine
Vibration Rectification Error		-	0.002°/s/g ² rms	-	10-2,000Hz 10g rms
Vibration Induced Noise		-	0.01°/s rms/g ² rms	-	10-2,000Hz 10g rms
MTTF		-	70,000hr	-	Calculation for continuous operation at +85°C
Electrical					
Supply Voltage (Functional)		4.75V	-	5.25V	-
Supply Voltage (Full Specification)		4.85V	-	5.25V	-
Current Consumption		-	60mA	70mA	-

© Copyright 2015 Silicon Sensing Systems Limited. All rights reserved. Silicon Sensing is an Atlantic Inertial Systems, Sumitomo Precision Products joint venture company. Specification subject to change without notice.

CRH02

Technical Datasheet

Analogue Angular Rate Sensor

High Performance MEMS Gyroscope

**SILICON
SENSING** 

www.siliconsensing.com

4 Absolute Maximum

Parameter	Minimum	Maximum
Electrical		
Supply Voltage	–	6.0V
ESD Protection	–	2kV HBM
Temperature		
Operating	-40°C	85°C
Storage	-40°C	100°C
Humidity (Non-condensing)	–	95%

5 Auxillary Output Signals

Parameter	Minimum	Typical	Maximum	Notes
Frequency				
Resonating Ring Frequency	27kHz	28.0kHz	29kHz	Output impedance 1kohm
Frequency Temperature Coefficient	-0.9Hz/°C	-0.80Hz/°C	-0.7Hz/°C	–
Temperature				
Temperature Sensor Offset at 0°C	–	-0.536V	–	With respect to REF output impedance 510ohm
Temperature Sensor Offset at 25°C	–	-0.830V	–	With respect to REF output impedance 510ohm
Temperature Sensor Scale Factor	-12.60mV/°C	-11.77mV/°C	-11.00mV/°C	Output impedance 510ohm

Note 1: The angle random walk is the value derived at the intercept of the $-1/2$ tangent on the Allan Variance plot and the 1 second correlation point (τ) divided by 60.

Note 2: The bias instability is the value at the minimum part of the Allan Variance plot, usually between 10s and 100s.

Note 3: The product must not be subjected to temperatures outside the recommended storage temperature range at any time.

Note 4: CRH02 is a precision measurement instrument do not drop it onto a hard surface from a height exceeding 300mm.

© Copyright 2015 Silicon Sensing Systems Limited. All rights reserved. Silicon Sensing is an Atlantic Inertial Systems, Sumitomo Precision Products joint venture company. Specification subject to change without notice.

CRH02-00-0100-132 Rev 1

Page 5



CRH02 Technical Datasheet

Analogue Angular Rate Sensor
High Performance MEMS Gyroscope



6 Typical Performance Characteristics

This section shows the typical performance of CRH02, supplied with a 5.0V supply unless stated otherwise.

6.1 Bias Characteristics

This section shows typical bias variation over temperature with, respect to the bias at +25°C.

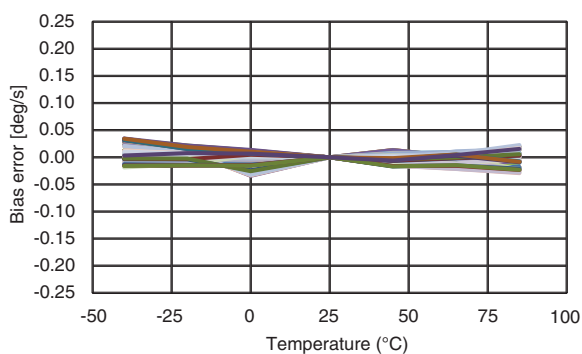

Figure 6.1 CRH02-025 Bias Variation over Temperature

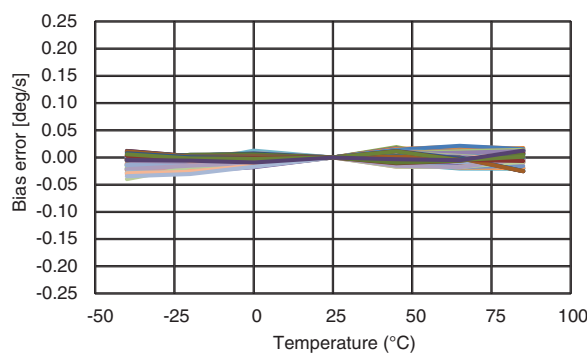

Figure 6.2 CRH02-100 Bias Variation over Temperature

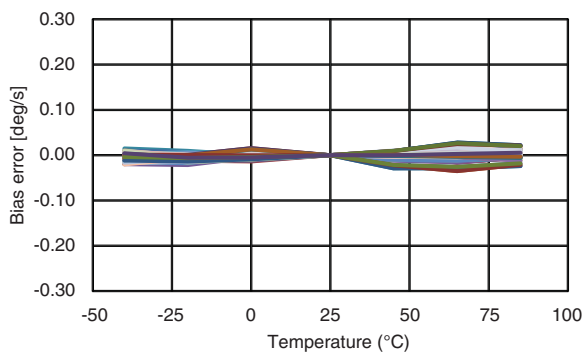

Figure 6.3 CRH02-200 Bias Variation over Temperature

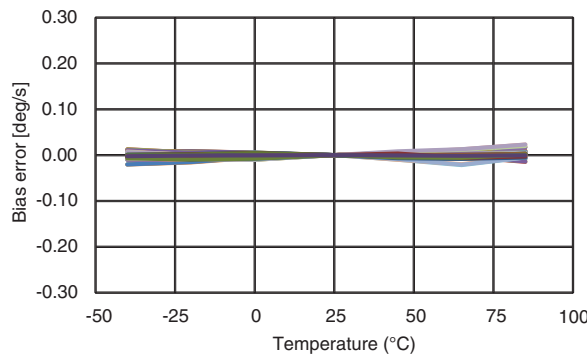

Figure 6.4 CRH02-400 Bias Variation over Temperature

CRH02 Technical Datasheet

Analogue Angular Rate Sensor
High Performance MEMS Gyroscope



6.2 Scale Factor Characteristics

This section shows the typical scale factor variation over temperature, with respect to the scale factor at +25°C.

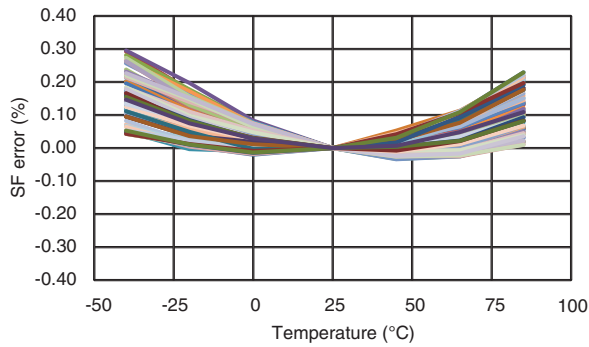

Figure 6.5 CRH02-025 Scale Factor Error over Temperature

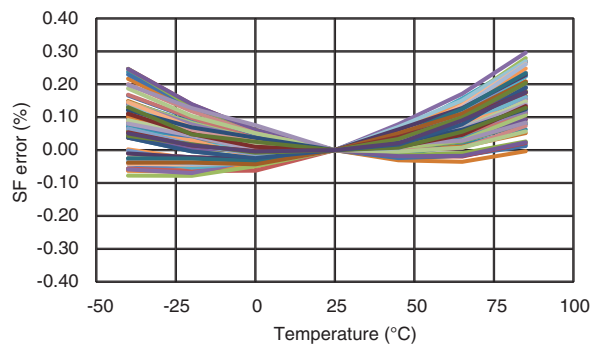

Figure 6.6 CRH02-100 Scale Factor Error over Temperature

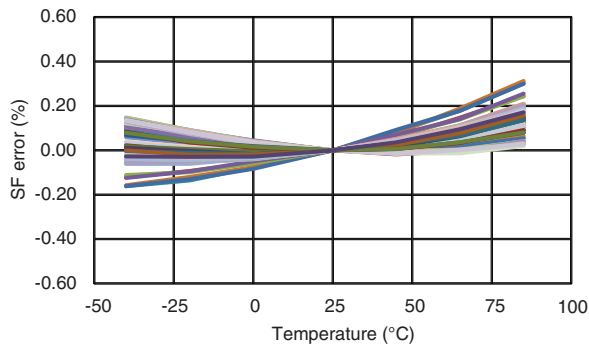

Figure 6.7 CRH02-200 Scale Factor Error over Temperature

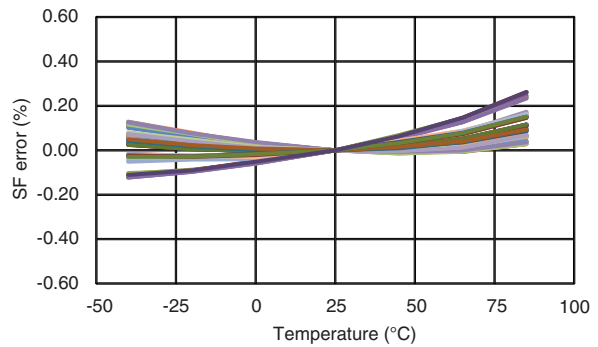

Figure 6.8 CRH02-400 Scale Factor Error over Temperature

CRH02 Technical Datasheet

Analogue Angular Rate Sensor
High Performance MEMS Gyroscope



6.3 Non-Linearity Characteristics

This section shows the typical non-linearity error over temperature.

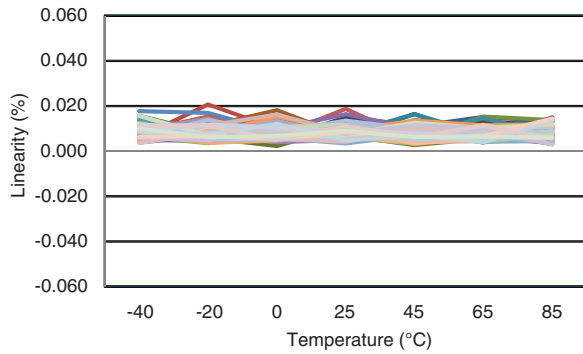

Figure 6.9 CRH02-025 Non-Linearity Error over Temperature

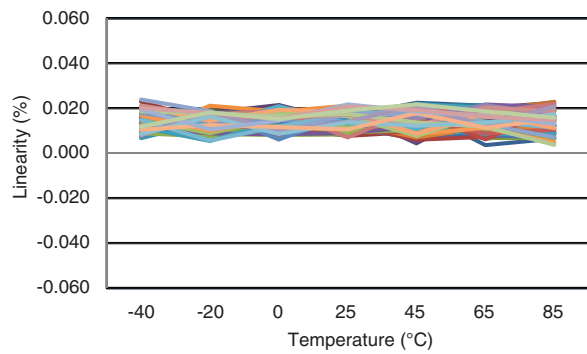

Figure 6.10 CRH02-100 Non-Linearity Error over Temperature

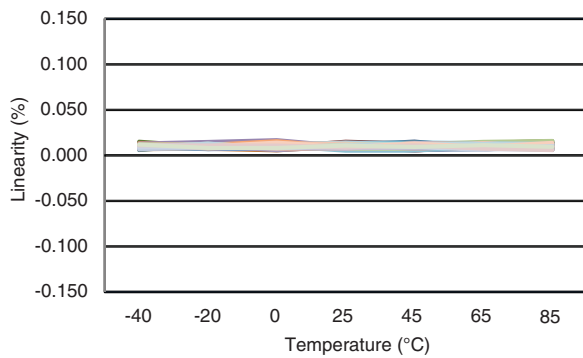

Figure 6.11 CRH02-200 Non-Linearity Error over Temperature

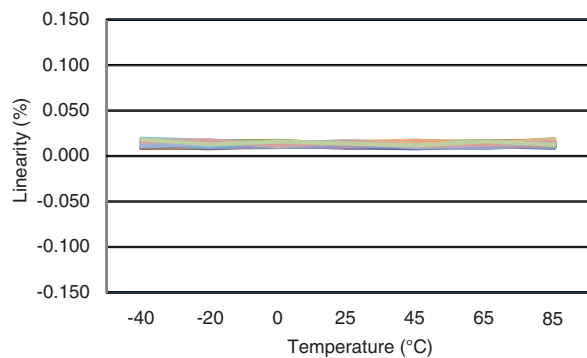

Figure 6.12 CRH02-400 Non-Linearity Error over Temperature

CRH02 Technical Datasheet

Analogue Angular Rate Sensor
High Performance MEMS Gyroscope



6.4 Bias Variation with Supply Voltage

This section shows the typical Bias Variation with Supply Voltage at 25°C.

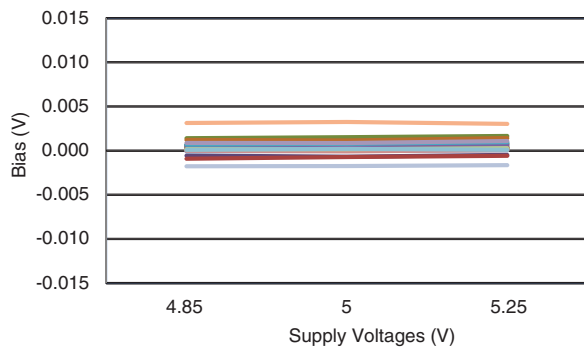

Figure 6.13 CRH02-025 Bias Variation with Supply Voltage

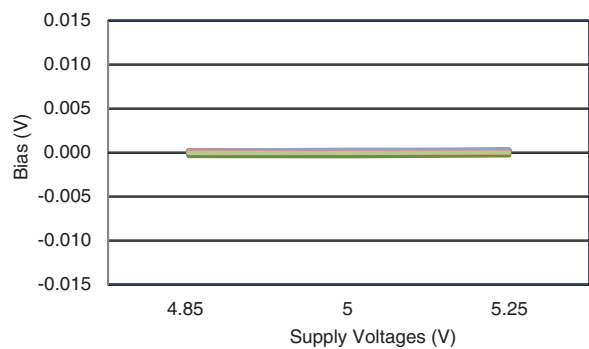

Figure 6.14 CRH02-100 Bias Variation with Supply Voltage

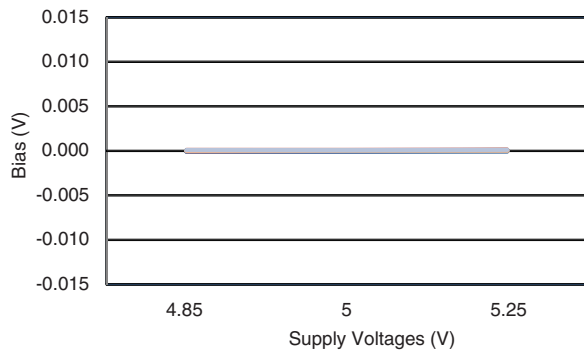

Figure 6.15 CRH02-200 Bias Variation with Supply Voltage

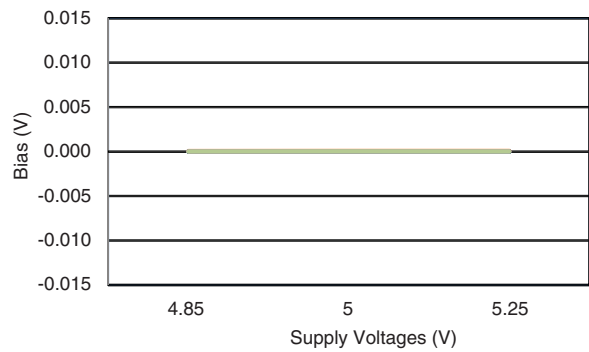

Figure 6.16 CRH02-400 Bias Variation with Supply Voltage

CRH02 Technical Datasheet

Analogue Angular Rate Sensor
High Performance MEMS Gyroscope



6.5 Scale Factor Variation with Supply Voltage

This section shows the typical Scale Factor Variation with Supply Voltage at 25°C.

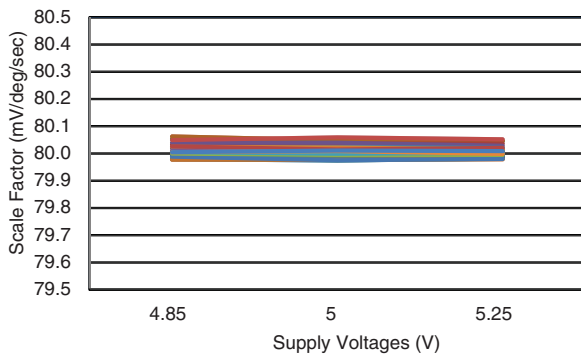

Figure 6.17 CRH02-025 Scale Factor Variation with Supply Voltage

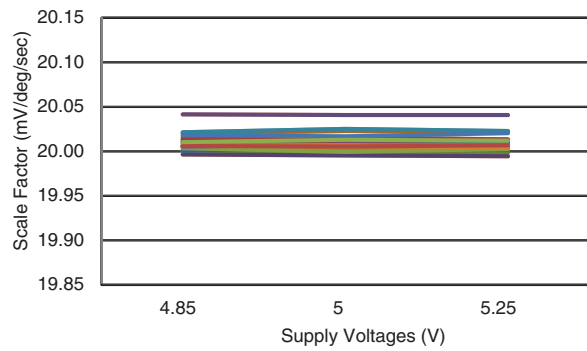

Figure 6.18 CRH02-100 Scale Factor Variation with Supply Voltage

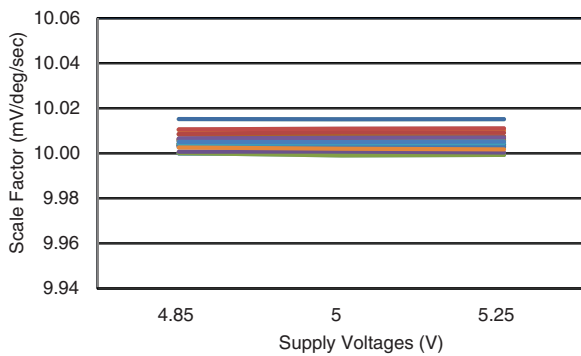

Figure 6.19 CRH02-200 Scale Factor Variation with Supply Voltage

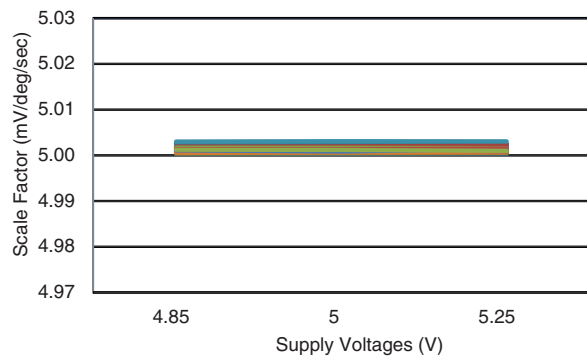

Figure 6.20 CRH02-400 Scale Factor Variation with Supply Voltage

CRH02 Technical Datasheet

Analogue Angular Rate Sensor
High Performance MEMS Gyroscope



www.siliconsensing.com

6.6 Current Consumption with Temperature

This section shows the typical Current Consumption over temperature.

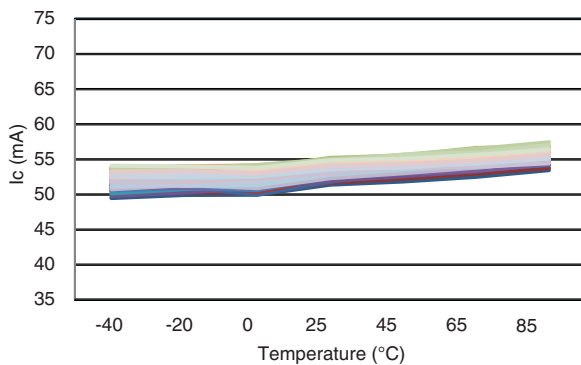

Figure 6.21 CRH02-025 Current Consumption over Temperature

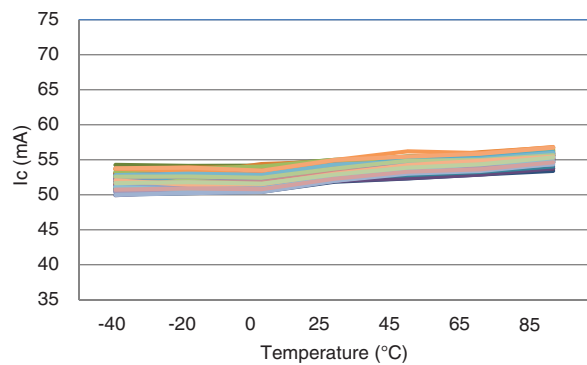

Figure 6.22 CRH02-100 Current Consumption over Temperature

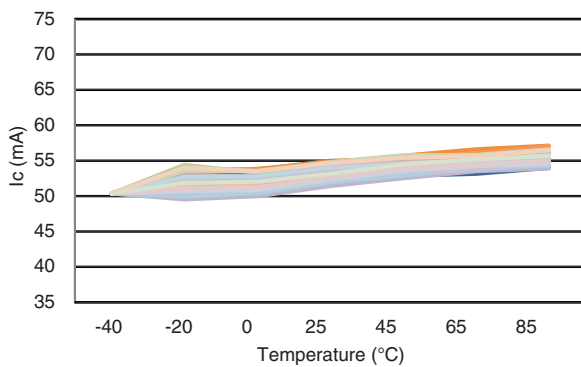

Figure 6.23 CRH02-200 Current Consumption over Temperature

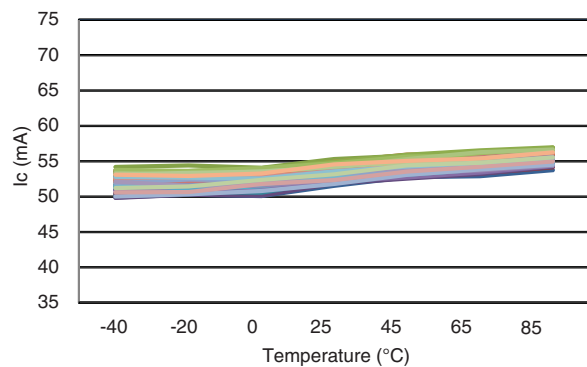

Figure 6.24 CRH02-400 Current Consumption over Temperature

© Copyright 2015 Silicon Sensing Systems Limited. All rights reserved. Silicon Sensing is an Atlantic Inertial Systems, Sumitomo Precision Products joint venture company. Specification subject to change without notice.

CRH02 Technical Datasheet

Analogue Angular Rate Sensor
High Performance MEMS Gyroscope



6.7 Allan Variance Current Consumption with Temperature

This section shows the typical Allan Variance graphs for the CRH02s at constant temperature.

Figure 6.25 shows a general Allan Variance graph as a guide for calculating Bias Instability and Angle Random Walk. The Angle Random Walk is calculated as follows:

- A line is drawn tangential to the Allan Variance graph at a -1/2 gradient (on a log-log plot).
- The line is extrapolated to intercept the 1 second correlation point (tau). The value at the intercept point is noted.
- The Angle Random Walk is this value, in units of degrees/hour, divided by 60. In the Figure 6.25, the line intercept the 1 second correlation time at 0.57°/h, giving an Angle Random Walk of 0.01°/h.

The Bias Instability is value at the minimum part of the Allan Variance plot, usually between correlation times of 10s and 100s. In the Figure 6.25, the Bias Instability is approximately 0.05°/h.

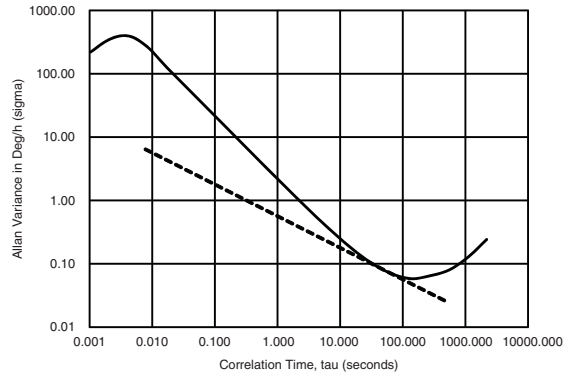

Figure 6.25 Derivation of Angle Random Walk and Bias Instability

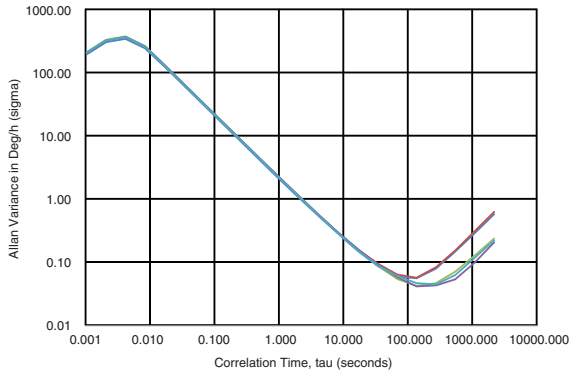

Figure 6.26 CRH02-025 Allan Variance

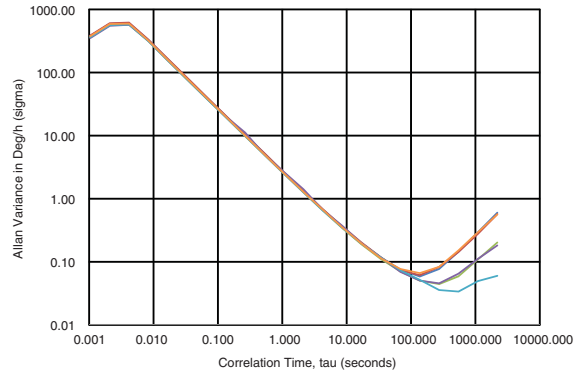

Figure 6.27 CRH02-100 Allan Variance

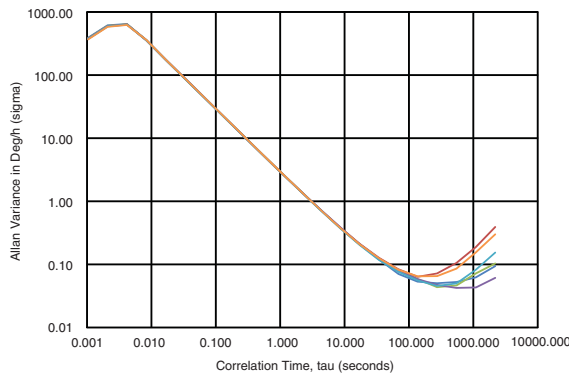

Figure 6.28 CRH02-200 Allan Variance

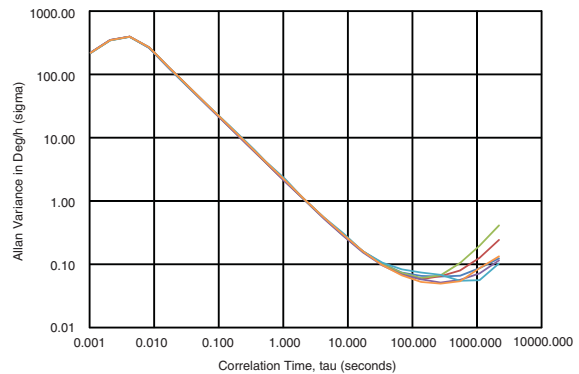
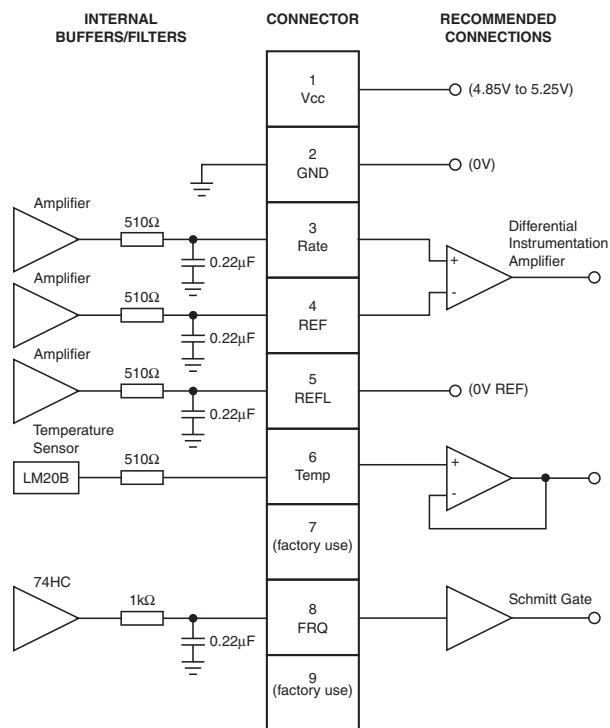

Figure 6.29 CRH02-400 Allan Variance

CRH02 Technical Datasheet

Analogue Angular Rate Sensor
High Performance MEMS Gyroscope

7 Interface



C.G. 18668

Figure 7.1 Typical Interface Schematic

Pin Number	Pin Name	Signal Direction (I/O)	Accessory Cable	Function
1	Vcc	-	Red	Power supply to Sensor (4.85V~5.25V)
2	GND	-	Black	Power ground
3	Rate	Output	White	Rate output with respect to REF
4	REF	Output	Green	Reference voltage Datum for Rate, Temp
5	REFL	Output	Grey	Reference Low voltage
6	Temp	Output	Yellow	Temperature output with respect to REF
7	DNC	-	-	Do Not Connect (factory use)
8	FRQ	Output	Blue	Second Harmonic Resonating Ring Frequency output
9	DNC	-	-	Do Not Connect (factory use)

Table 7.1 Connector Pin Identifications

© Copyright 2015 Silicon Sensing Systems Limited. All rights reserved. Silicon Sensing is an Atlantic Inertial Systems, Sumitomo Precision Products joint venture company. Specification subject to change without notice.

CRH02 Technical Datasheet

Analogue Angular Rate Sensor
High Performance MEMS Gyroscope

**SILICON
SENSING** 

www.siliconsensing.com

7.1 Supply Voltage

The CRH02 consists of angular rate sensors with non-ratiometric characteristics that are independent of the supplied voltage, provided the supplied voltage is within the operating voltage range.

The supply voltage, including ripple voltage and power supply noise, must be controlled so that it does not drop below 4.85V in order to maintain full performance.

Warning

The resonant frequency of the gyroscope is nominally 14kHz. If more than one gyroscope is operated from a common power supply, there is the possibility of interference between them, causing a beat frequency to become apparent in their outputs. Where optimum performance is required, it is therefore recommended that the power supply to each gyroscope is carefully controlled in order to maintain isolation between them. One solution is to operate each gyroscope from an independent low drop out, linear power regulator.

7.2 Mating Cable Assembly

Each CRH02 is supplied with a single mating cable assembly (see Figure 1.3).

The cable assembly is Hirose Electric Co., Ltd.
Part Number: DF13A-9S-1.25C.

7.3 Temperature Sensor

The temperature sensor uses a LM20B device, internally connected as shown in Figure 7.2.

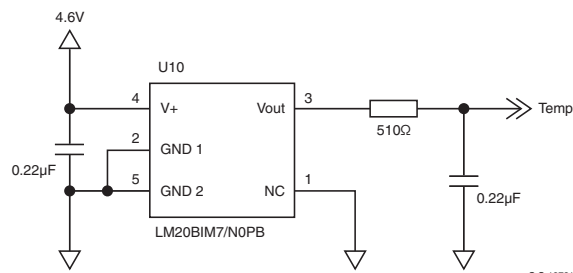

Figure 7.2 Temperature Sensor

The output at 0°C is typically +1.864V with respect to REFL. The temperature coefficient is typically -11.77 mV/°C.

The output can be measured with respect to REFL or can be put through a differential input instrumentation amplifier, referenced to the REF pin, in which case the offset at 0°C is typically -0.536V. At +25°C, the output is typically -0.830V with respect to REF. The temperature sensor is not intended for use as a thermometer, since they are not calibrated on the Celsius scale. They are intended only as a temperature reference for thermal compensation techniques.

7.4 Rate and Ref Outputs

Both the Rate and the REF outputs are protected by a resistor before the output pins. The resistor value is 510 ohms.

It is important to take these resistor values into account when calculating the gains of external differential amplifiers. It is also recommended that the REF signal is buffered if it is used as a reference for more than one signal.

It is recommended that the Rate Output is differentially sensed using a precision instrumentation amplifier, referenced to the REF output. A reference Low (0V), REFL is also provided as a ground reference for external ADCS (see Figure 7.1).

The Offset of the instrumentation amplifier should be derived from the host stage (e.g. derived from the ADC REF Voltage) or from the signal ground if the following stage is an analogue stage.

7.5 Frequency Outputs

This is CMOS Digital (74HC series) compatible digital output at two times the frequency of the sensor head. It is provided to give an indication of the temperature of the MEMS sensor head. The nominal frequency is 28 KHz with a typical temperature coefficient of -0.8 Hz/°C.

The signal is protected with a 1Kohm resistor before being output from the CRH02. It is recommended that this signal is buffered with a CMOS Schmitt Gate such as 74HC12, or TC7S14F. The signal can be used to accurately measure the temperature of the MEMS structure.

An example of measuring the MEMS temperature is to use a precision crystal oscillator (operating at a very high frequency, for example 20, 40 or 60 MHz) to measure the frequency of the ring by measuring the time (oscillator clock cycles) to count to a defined number of ring cycles.

CRH02 Technical Datasheet

Analogue Angular Rate Sensor
High Performance MEMS Gyroscope

SILICON SENSING
www.siliconsensing.com

8 Glossary of Terms

ADC	Analogue to Digital Converter
ARW	Angular Random Walk
BW	Bandwidth
C	Celsius or Centigrade
DAC	Digital to Analogue Converter
DPH	Degrees Per Hour
DPS	Degrees Per Second
DRIE	Deep Reactive Ion Etch
EMC	Electro-Magnetic Compatibility
ESD	Electro-Static Damage
F	Farads
h	Hour
HBM	Human Body Model
Hz	Hertz, Cycle Per Second
K	Kilo
MEMS	Micro-Electro Mechanical Systems
mV	Milli-Volts
NEC	Not Electrically Connected
NL	Scale Factor Non-Linearity
PD	Primary Drive
PP	Primary Pick-Off
RC	Resistor and Capacitor filter
s	Seconds
SF	Scale Factor
SMT	Surface Mount Technology
SOG	Silicon On Glass
SD	Secondary Drive
SP	Secondary Pick-Off
T.B.A.	To Be Announced
T.B.D.	To Be Described
V	Volts
VSG	Vibrating Structure Gyroscope
w.r.t.	With Respect To

9 Part Markings

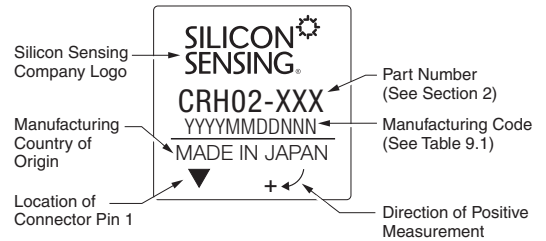

Figure 9.1 Part Marking

Data	Code	Range
Manufacture Year	YYYY	0000 - 9999
Manufacture Month	MM	01 - 12
Manufacture Day	DD	01 - 31
Manufacture Number	NNN	001 - 999

Table 9.1 Manufacturing Code

10 Silicon MEMS Ring Sensor (Gyro)

The silicon MEMS ring is 6mm diameter by 100 μ m thick, fabricated by Silicon Sensing Systems using a DRIE (Deep Reactive Ion Etch) bulk silicon process. The ring is supported in free-space by sixteen pairs of symmetrical legs which isolate the ring from the supporting structure on the outside of the ring.

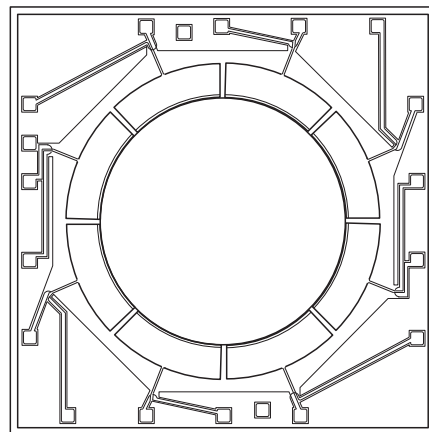

Figure 10.1 Silicon MEMS Ring

CRH02 Technical Datasheet

Analogue Angular Rate Sensor

High Performance MEMS Gyroscope

SILICON SENSING

www.siliconsensing.com

The bulk silicon etch process and unique patented ring design enable close tolerance geometrical properties for precise balance and thermal stability and, unlike other MEMS gyros, there are no small gaps to create problems of interference and stiction. These features contribute significantly to CRH02's bias and scale factor stability over temperature, and vibration immunity. Another advantage of the design is its inherent immunity to acceleration induced rate error, or 'g-sensitivity'.

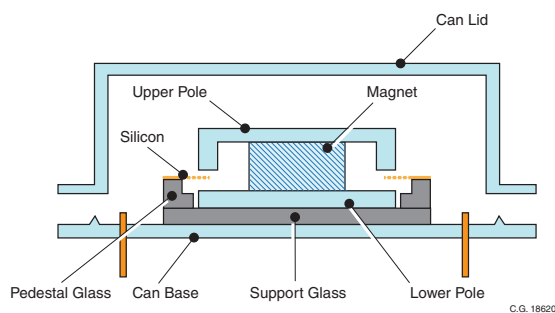

Figure 10.2 MEMS VSG3 Sensor

The ring is essentially divided into 8 sections with two conductive tracks in each section. These tracks enter and exit the ring on the supporting legs. The silicon ring is bonded to a glass pedestal which in turn is bonded to a glass support base. A magnet, with upper and lower poles, is used to create a strong and uniform magnetic field across the silicon ring. The complete assembly is mounted within a hermetic can.

The tracks along the top of the ring form two pairs of drive tracks and two pairs of pick-off tracks. Each section has two loops to improve drive and pick-off quality.

One pair of diametrically opposed tracking sections, known as the Primary Drive PD section, is used to excite the $\cos 2\theta$ mode of vibration on the ring. This is achieved by passing current through the tracking, and because the tracks are within a magnetic field causes motion on the ring. Another pair of diametrically opposed tracking sections is known as the Primary Pick-off PP section is used to measure the amplitude and phase of the vibration on the ring. The Primary Pick-off sections are in the sections 90° to those of the Primary Drive sections. The drive amplitude and frequency is controlled by a precision closed loop electronic architecture with the frequency controlled by a Phase Locked Loop (PLL), operating with a

Voltage Controlled Oscillator (VCO), and amplitude controlled with an Automatic Gain Control (AGC) system. The primary loop therefore establishes the vibration on the ring and the closed loop electronics is used to track frequency changes and maintain the optimal amplitude of vibration over temperature and life. The loop is designed to operate at about 14kHz.

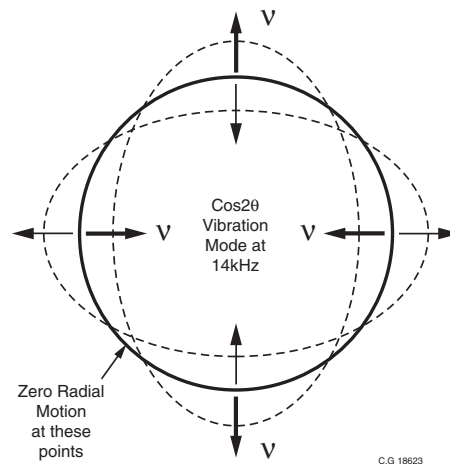

Figure 10.3 Primary Vibration Mode

Having established the $\cos 2\theta$ mode of vibration on the ring, the ring becomes a Coriolis Vibrating Structure Gyroscope. When the gyroscope is rotated about its sense axis the Coriolis force acts tangentially on the ring, causing motions at 45° displaced from the primary mode of vibration. The amount of motion at this point is directly proportional to the rate of turn applied to the gyroscope. One pair of diametrically opposed tracking sections, known as the Secondary Pick-off SP section, is used to sense the level of this vibration. This is used in a secondary rate nulling loop to apply a signal to another pair of secondary sections, known as the Secondary Drive SD. The current applied to the Secondary Drive to null the secondary mode of vibration is a very accurate measure of the applied angular rate. All of these signals occur at the resonant frequency of the ring. The Secondary Drive signal is demodulated to baseband to give a voltage output directly proportional to the applied rate in free space.

CRH02

Technical Datasheet
Analogue Angular Rate Sensor
High Performance MEMS Gyroscope

SILICON SENSING
www.siliconsensing.com

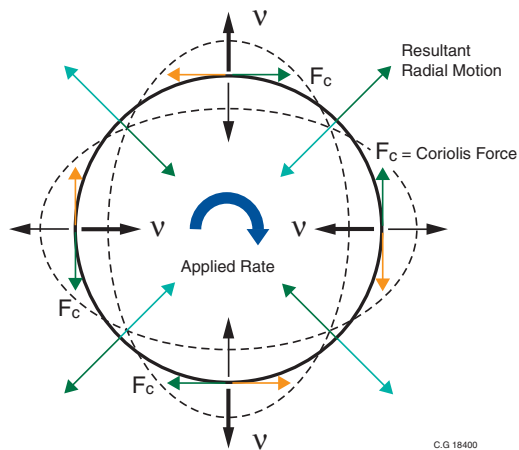

Figure 10.4 Secondary Vibration Mode

The closed loop architecture on both the primary and secondary loops results in excellent bias, scale factor and non-linearity control over a wide range of operating environments and life. The dual loop design, introduced into this new Sensor Head design, coupled with improved geometric symmetry results in excellent performance over temperature and life. The discrete electronics employed in CRH02, ensures that performance is not compromised.

© Copyright 2015 Silicon Sensing Systems Limited. All rights reserved. Silicon Sensing is an Atlantic Inertial Systems, Sumitomo Precision Products joint venture company. Specification subject to change without notice.

CRH02-00-0100-132 Rev 1

Page 17

CRH02 Technical Datasheet

Analogue Angular Rate Sensor

High Performance MEMS Gyroscope



www.siliconsensing.com

Notes

Silicon Sensing Systems Limited
Clifford Road Southway
Plymouth Devon
PL6 6DE United Kingdom
T: +44 (0)1752 723330
F: +44 (0)1752 723331
E: sales@siliconsensing.com
W: siliconsensing.com

Silicon Sensing Systems Japan Limited
1-10 Fuso-Cho
Amagasaki
Hyogo 6600891 Japan
T: +81 (0)6 6489 5868
F: +81 (0)6 6489 5919
E: sssj@spp.co.jp
W: siliconsensing.com

Specification subject to change without notice.

© Copyright 2015
Silicon Sensing Systems Limited
All rights reserved.

Printed in England 02/2015
Date 10/03/2015

CRH02-00-0100-132 Rev 1
DCR No. 710008488

© Copyright 2015 Silicon Sensing Systems Limited. All rights reserved. Silicon Sensing is an Atlantic Inertial Systems, Sumitomo Precision Products joint venture company.
Specification subject to change without notice.



We are here for you. Addresses and Contacts

Sales Switzerland & Liechtenstein

Matthias Rüegg
Ruhbergstrasse 32
CH-9230 Flawil

Phone +41 44 877 35 18
Mobile+41 76 491 66 66
Fax +41 44 877 35 19

matthias.rueegg@pewatron.com

Sales International Key Accounts

Peter Felder
Thurgauerstrasse 66
CH-8052 Zürich

Phone +41 44 877 35 05
Mobile+41 79 406 49 83
Fax +41 44 877 35 25

peter.felder@pewatron.com

Sales Germany

Postcode 00000–59999
Postcode 80000–99999

Kurt Stritzelberger
Neumarkter Str. 86a
D-81673 Munich

Phone +49 89 260 38 47
Mobile+49 171 803 41 35
Fax +49 89 43 10 91 91

kurt.stritzelberger@pewatron.com

Postcode 60000–79999

Dieter Hirthe
Auf der Entenweide 4
69502 Hemsbach

Tel. +49 6201 508 9250
Mobil +49 1637 627 430
Fax +49 6201 508 9751

dieter.hirthe@pewatron.com

Sales Austria

Kurt Stritzelberger
Neumarkter Str. 86a
D-81673 Munich

Phone +49 89 260 38 47
Mobile+49 17 18 03 41 35
Fax +49 89 43 10 91 91

kurt.stritzelberger@pewatron.com

Sales Other Countries / Product Management

Sensors

Physical Sensors
Data Acquisition

Thomas Clausen
Phone +41 44 877 35 13
thomas.clausen@pewatron.com

Geometrical Sensors

Eric Letsch
Phone +41 44 877 35 14
eric.letsch@pewatron.com

Power Supplies

DC-DC Converters
Switching Power Supplies
DC-AC Inverters

Sebastiano Leggio
Phone +41 44 877 35 06
sebastiano.leggio@pewatron.com

E-Components

Current Sensors
Man Machine Interface
Measurement Probes

Sebastiano Leggio
Phone +41 44 877 35 06
sebastiano.leggio@pewatron.com

PEWATRON AG
Thurgauerstrasse 66
CH-8052 Zurich

Phone +41 44 877 35 00
Fax +41 44 877 35 25

www.pewatron.com
info@pewatron.com