

**Features**

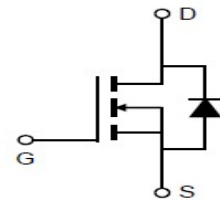
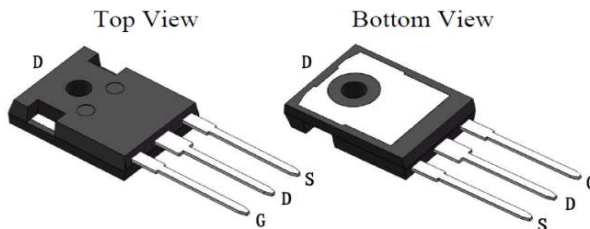
- CRM(CQ) Super\_Junction technology
- Much lower Ron\*A performance for On-state efficiency
- Better efficiency due to very low FOM
- Ultra-fast body diode
- Qualified for industrial grade applications according to JEDEC

**Applications**

- LED/LCD/PDP TV and monitor Lighting
- Solar/Renewable/UPS-Micro Inverter System
- Charger
- Power Supply

**Product Summary**

$V_{DS,min}$	650V
$R_{DS(on),typ}$	110mΩ
$I_D$	25A

**100% DVDS Tested**
**100% Avalanche Tested**

**Package Marking and Ordering Information**

Part #	Marking	Package	Packing	Reel Size	Tape Width	Qty
CRJQ140N65G2F	CRJQ140N65G2F	TO-247-3L	Tube	N/A	N/A	25pcs

**Absolute Maximum Ratings**

Parameter	Symbol	Value	Unit
Drain-source voltage	$V_{DS}$	650	V
Continuous drain current <sup>1)</sup> $T_C = 25^\circ\text{C}$ $T_C = 100^\circ\text{C}$	$I_D$	25 16	A
Pulsed drain current <sup>2)</sup> ( $T_C = 25^\circ\text{C}$ , $t_p$ limited by $T_{j,max}$ )	$I_{D,pulse}$	75	A
Avalanche energy, single pulse (L=30mH)	$E_{AS}$	300	mJ
MOSFET dv/dt ruggedness	dv/dt	50	V/ns
Gate-Source voltage	$V_{GS}$	±30	V
Power dissipation ( $T_C = 25^\circ\text{C}$ )	$P_{tot}$	207	W
Continuous diode forward current( $T_C = 25^\circ\text{C}$ )	$I_S$	25	A
Diode pulse current <sup>2)</sup> ( $T_C = 25^\circ\text{C}$ )	$I_{S,pulse}$	75	A
Recovery diode dv/dt <sup>3)</sup>	dv/dt	50	V/ns
Operating junction and storage temperature	$T_j, T_{stg}$	-55...+150	°C

 1) Limited by  $T_{j,max}$ . Maximum Duty Cycle  $D = 0.50$ 

 2) Pulse width  $t_p$  limited by  $T_{j,max}$ 

 3) Identical low side and high side switch with identical  $R_g$

**Thermal Resistance**

Parameter	Symbol	Value			Unit	Test Condition
		min.	typ.	max.		
Thermal resistance, junction – case	$R_{thJC}$	-	0.43	0.60	°C/W	
Thermal resistance, junction – ambient	$R_{thJA}$	-	-	46	°C/W	

**Electrical Characteristic (at  $T_j = 25\text{ °C}$ , unless otherwise specified)**

Parameter	Symbol	Value			Unit	Test Condition
		min.	typ.	max.		

**Static Characteristic**

Drain-source breakdown voltage	$BV_{DSS}$	650	-	-	V	$V_{GS}=0V, I_D=250\mu A$
Gate threshold voltage	$V_{GS(th)}$	3.2	-	4.6	V	$V_{DS}=V_{GS}, I_D=250\mu A$
Zero gate voltage drain current	$I_{DSS}$	-	-	5	$\mu A$	$V_{DS}=650V, V_{GS}=0V$ $T_j=25\text{ °C}$
		-	220	-		$T_j=150\text{ °C}$
Gate-source leakage current	$I_{GSS}$	-	-	$\pm 100$	nA	$V_{GS}=\pm 30V, V_{DS}=0V$
Drain-source on-state resistance	$R_{DS(on)}$	-	110	140	mΩ	$V_{GS}=10V, I_D=11A,$ $T_j=25\text{ °C}$
		-	250	-		$T_j=150\text{ °C}$
Transconductance	$g_{fs}$	-	16.5	-	S	$V_{DS}=20V, I_D=11A$

**Dynamic Characteristic**

Input Capacitance	$C_{iss}$	-	1595	-	pF	$V_{GS}=0V, V_{DS}=100V,$ $f=1MHz$
Output Capacitance	$C_{oss}$	-	90	-		
Reverse Transfer Capacitance	$C_{rss}$	-	1.6	-		
Gate Total Charge	$Q_g$	-	46	-	nC	$V_{GS}=10V, V_{DS}=480V,$ $I_D=11A$
Gate-Source charge	$Q_{gs}$	-	14	-		
Gate-Drain charge	$Q_{gd}$	-	24	-		
Gate plateau voltage	$V_{plateau}$	-	7.7	-	V	
Turn-on delay time	$t_{d(on)}$	-	60	-	ns	$V_{GS}=10V, I_D=11A,$ $V_{DS}=400V, R_g=27\Omega$
Rise time	$t_r$	-	61	-		
Turn-off delay time	$t_{d(off)}$	-	140	-		
Fall time	$t_f$	-	31	-		
Gate resistance	$R_{g,int}$	-	10	-	Ω	$f=1MHz$

**Body Diode Characteristic**

Parameter	Symbol	Value			Unit	Test Condition
		min.	typ.	max.		
Body Diode Forward Voltage	$V_{SD}$	0.7	0.86	1.1	V	$V_{GS}=0V, I_{SD}=11A$
Body Diode Reverse Recovery Time	$t_{rr}$	-	120	-	ns	$I_{SD}=11A$ $di_F/dt=100A/\mu s$
Body Diode Reverse Recovery Charge	$Q_{rr}$	-	0.63	-	$\mu C$	$V_{DS}=400V$

## Typical Performance Characteristics

Fig 1. Output Characteristics ( $T_j=25^\circ\text{C}$ )

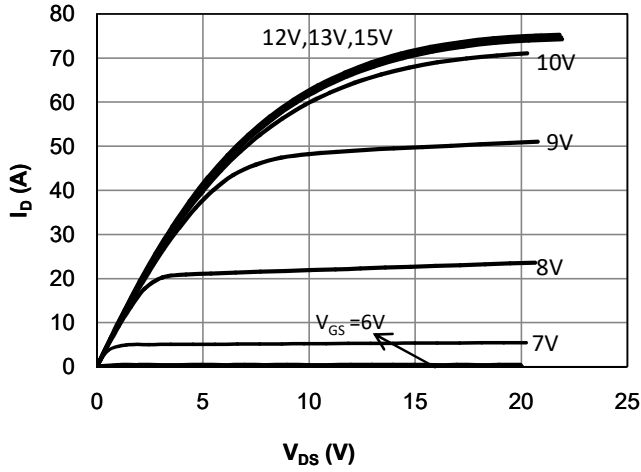


Fig 2. Output Characteristics ( $T_j=150^\circ\text{C}$ )

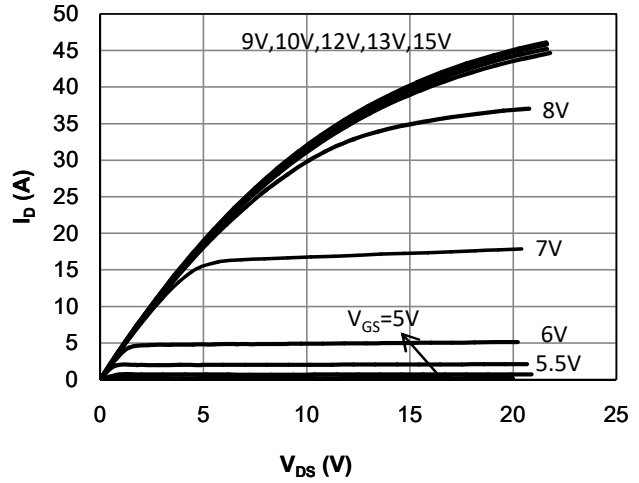


Fig 3: Transfer Characteristics

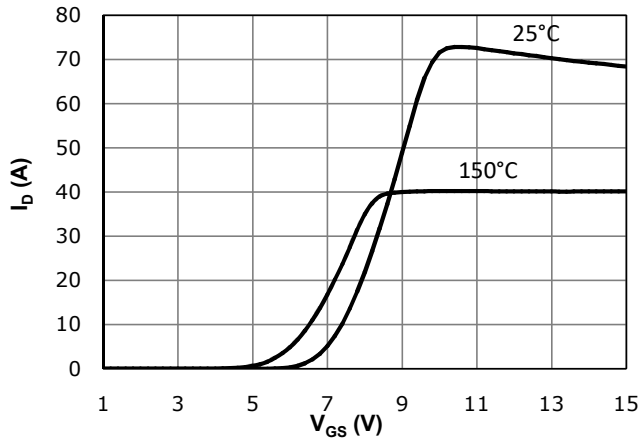


Fig 4:  $V_{TH}$  vs.  $T_j$  Temperature Characteristics

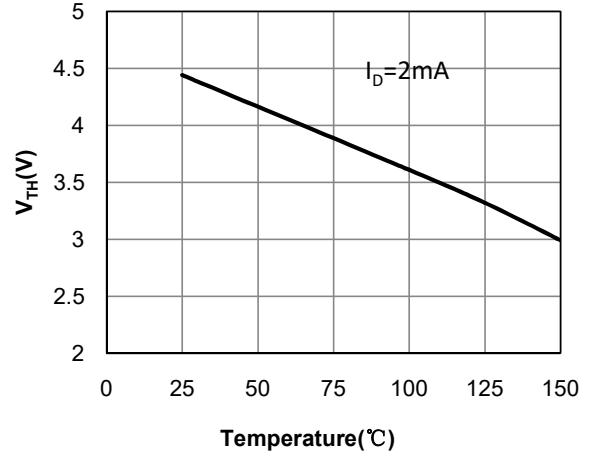


Fig 5:  $R_{DS(on)}$  vs.  $I_{DS}$  Characteristics ( $T_j=25^\circ\text{C}$ )

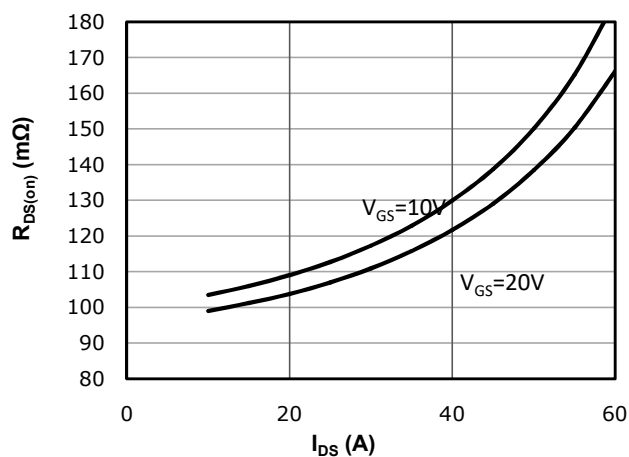
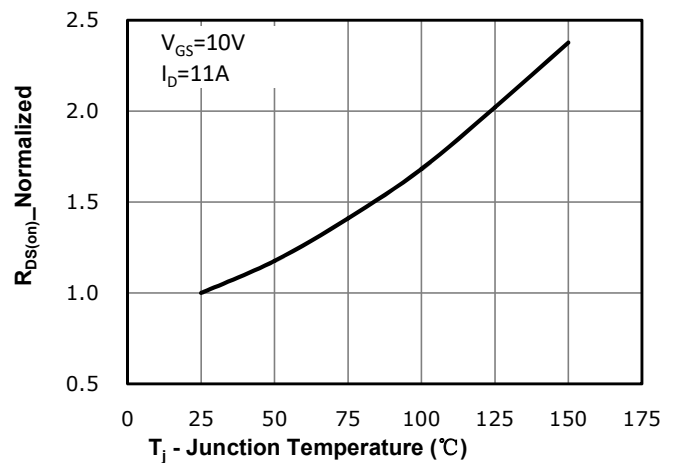
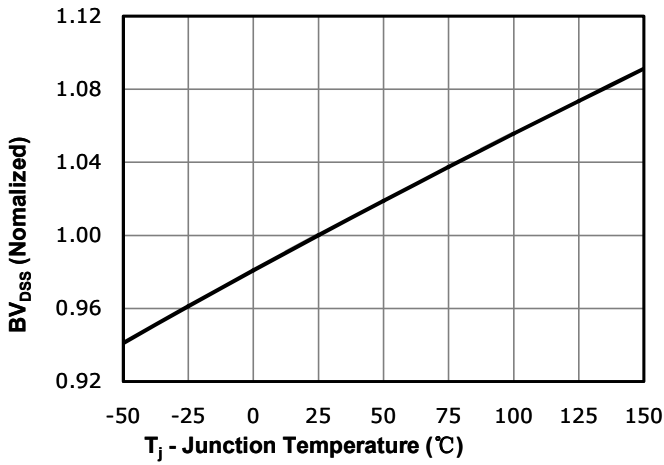


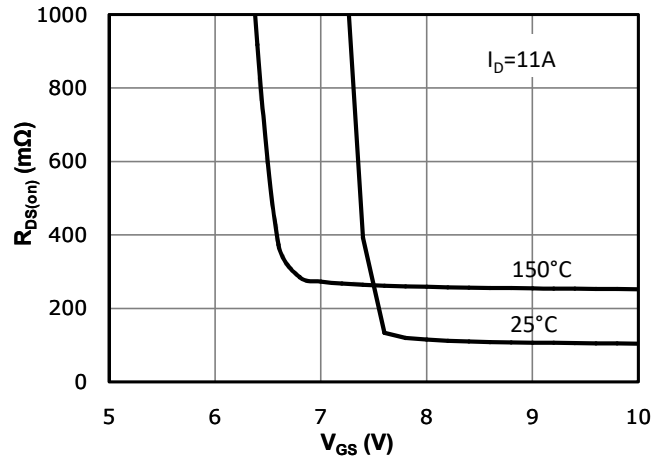
Fig 6:  $R_{DS(on)}$  vs. Temperature



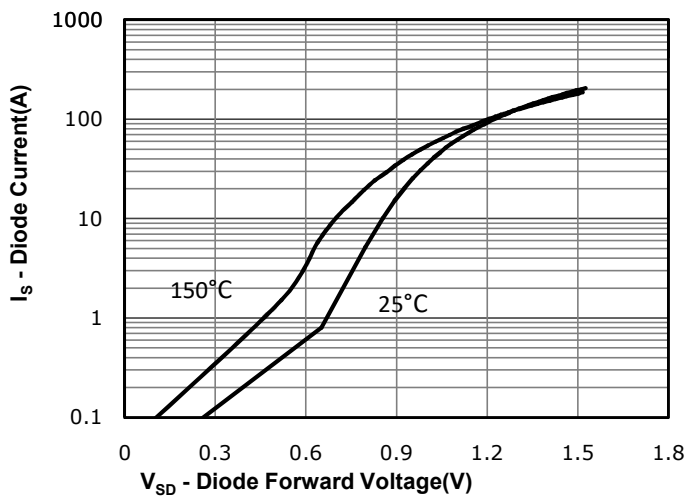
**Fig 7:  $BV_{DSS}$  vs. Temperature**



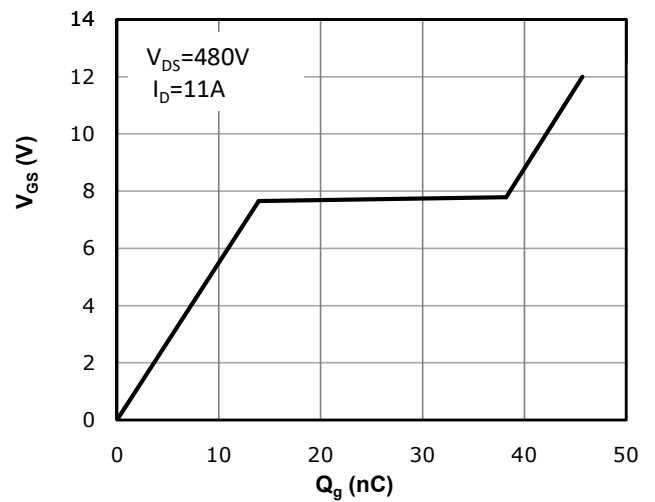
**Fig 8:  $R_{DS(on)}$  vs. Gate Voltage**



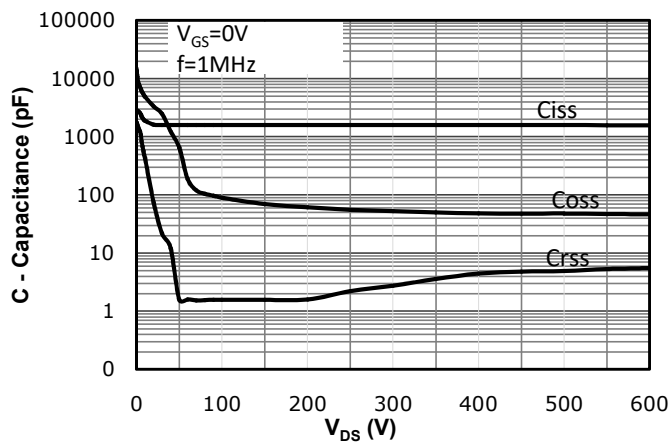
**Fig 9: Body-diode Forward Characteristics**



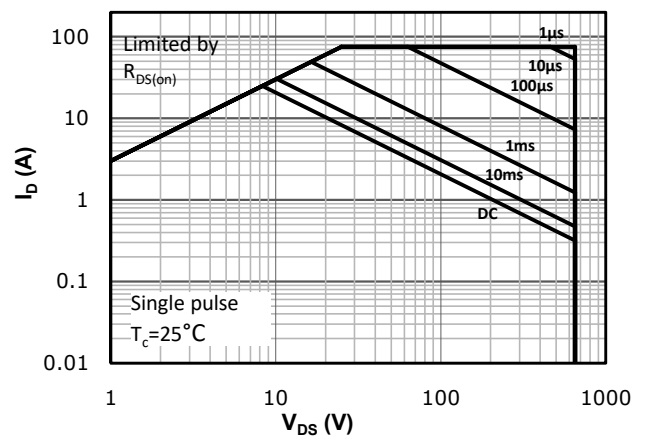
**Fig 10: Gate Charge Characteristics**



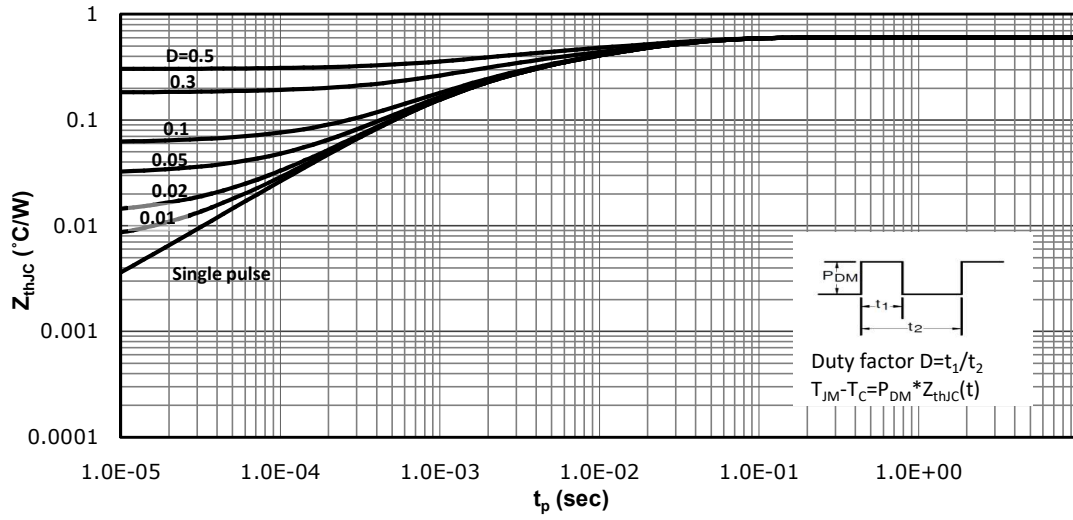
**Fig 11: Capacitance Characteristics**



**Fig 12: Safe Operating Area**

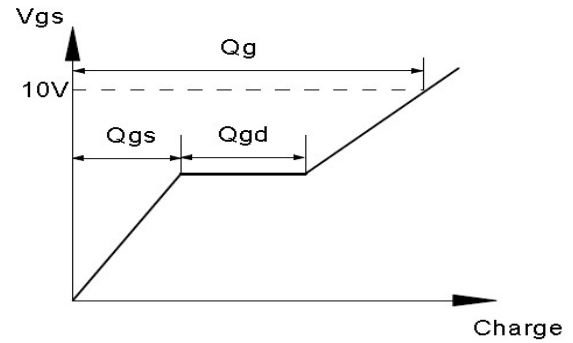
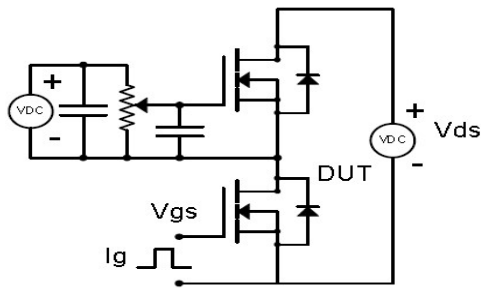


**Fig 13: Max. Transient Thermal Impedance**

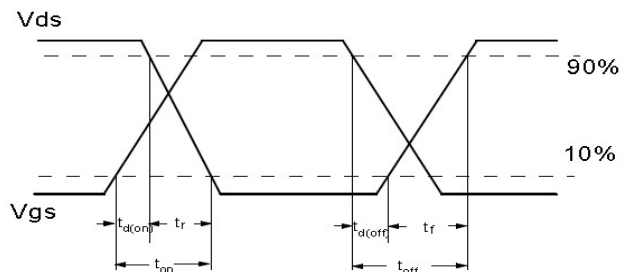
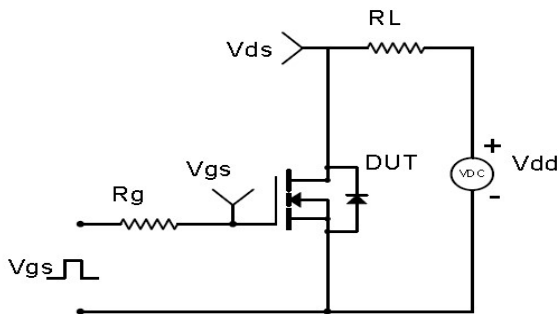


## Test Circuit & Waveform

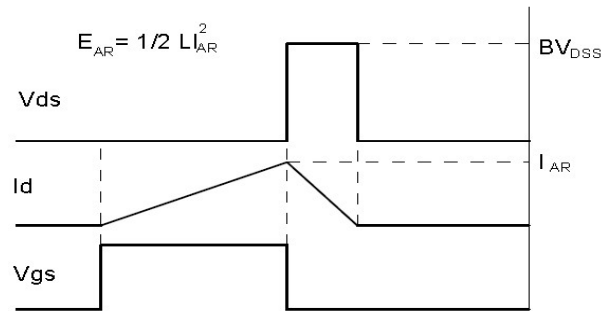
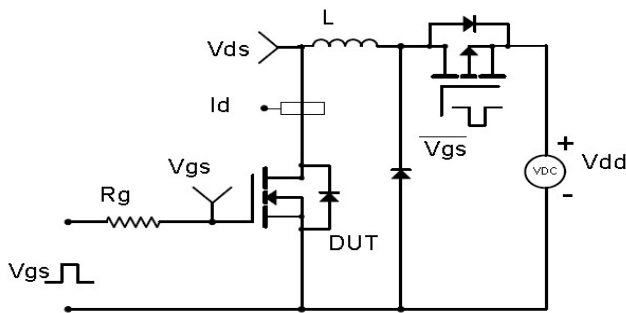
Gate Charge Test Circuit & Waveform



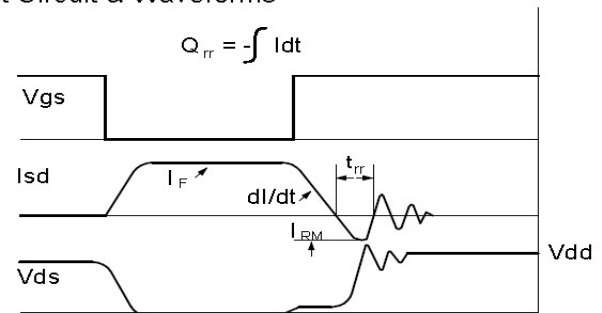
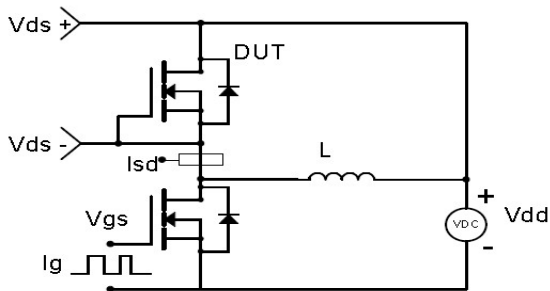
Resistive Switching Test Circuit & Waveforms

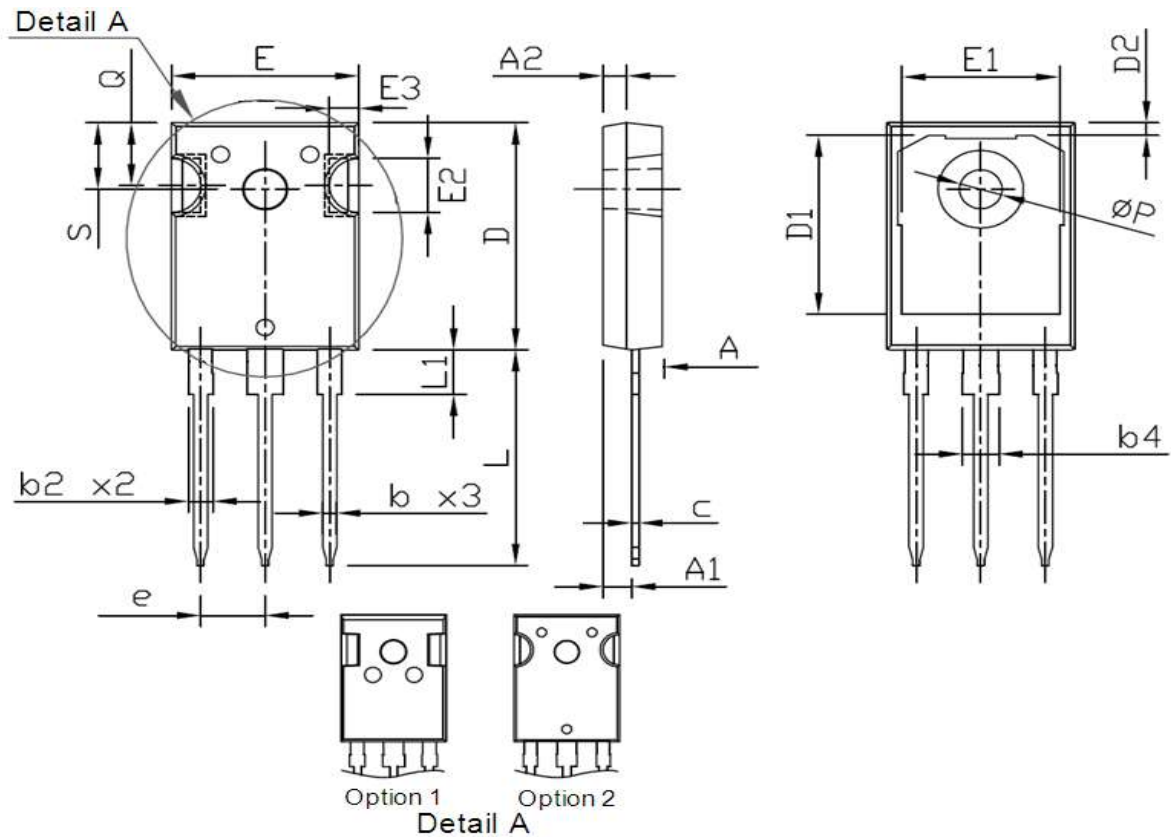


Unclamped Inductive Switching (UIS) Test Circuit & Waveforms



Diode Recovery Test Circuit & Waveforms



**Package Outline: TO-247**


Symbol	Dimensions In Millimeters		Dimensions In Inches	
	Min.	Max.	Min.	Max.
A	4.70	5.30	0.185	0.209
A1	2.20	2.60	0.087	0.102
A2	1.50	2.49	0.059	0.098
b	1.04	1.33	0.041	0.052
b2	1.90	2.41	0.075	0.095
b4	2.87	3.43	0.113	0.135
c	0.55	0.70	0.022	0.028
D	20.70	21.30	0.815	0.839
D1	16.25	17.65	0.640	0.695
D2	0.51	1.40	0.020	0.055
e	5.44 BSC.		0.214 BSC.	
E	15.50	16.30	0.610	0.642
E1	13.08	14.16	0.515	0.557
E2	3.80	5.49	0.150	0.216
E3	1.00	2.75	0.039	0.108
L	19.72	20.32	0.776	0.800
L1	3.85	4.50	0.152	0.177
Q	5.25	6.25	0.207	0.246
P	3.50	3.70	0.138	0.146
S	6.04	6.30	0.238	0.248



## Marking



**NOTE:**

NXBBAAAA

N	—WB code (Usually omitted)
X	—Assembly location code
BB	—Fab code
AAAA	—Lot code



**Revision History**

Revision	Date	Major changes
1.1	2023/7/9	Update marking

**Disclaimer**

Unless otherwise specified in the datasheet, the product is designed and qualified as a standard commercial product and is not intended for use in applications that require extraordinary levels of quality and reliability, such as automotive, aviation/aerospace and life-support devices or systems.

Any and all semiconductor products have certain probability to fail or malfunction, which may result in personal injury, death or property damage. Customer are solely responsible for providing adequate safe measures when design their systems.

CRM(CQ) reserves the right to improve product design, function and reliability without notice.