

Features

- CRM(CQ) Super_Junction technology
- Much lower Ron*A performance for On-state efficiency
- Better efficiency due to very low FOM
- Ultra-fast body diode
- Qualified for industrial grade applications according to JEDEC

Applications

- LED/LCD/PDP TV and monitor Lighting
- Solar/Renewable/UPS-Micro Inverter System
- Charger
- Power Supply

Product Summary

VDS	650V
R _{DS(on)_typ}	42mΩ
I _D	74A

100% DVDS Tested

100% Avalanche Tested

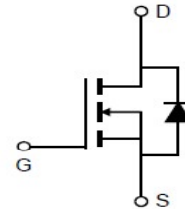
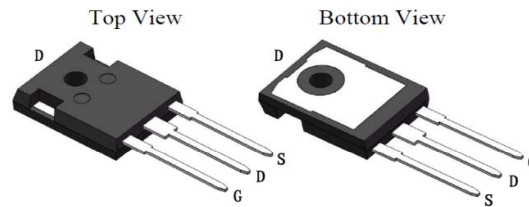

Package Marking and Ordering Information

Part #	Marking	Package	Packing	Reel Size	Tape Width	Qty
CRJQ41N65GCP	CRJQ41N65GCP	TO-247-3L	Tube	N/A	N/A	25/30pcs

Absolute Maximum Ratings(at T_j = 25 °C, unless otherwise specified)

Parameter	Symbol	Value	Unit
Drain-source voltage	V _{DS}	650	V
Continuous drain current ¹⁾ T _C = 25°C T _C = 100°C	I _D	74 47	A
Pulsed drain current ²⁾ (T _C = 25°C, t _p limited by T _{jmax})	I _{D pulse}	296	A
Avalanche energy, single pulse (L=30mH)	E _{AS}	1500	mJ
MOSFET dv/dt ruggedness	dv/dt	50	V/ns
Gate-Source voltage	V _{GS}	±30	V
Power dissipation (T _C = 25°C)	P _{tot}	687	W
Continuous diode forward current(T _C = 25°C)	I _S	74	A
Diode pulse current ²⁾ (T _C = 25°C)	I _{S pulse}	296	A
Recovery diode dv/dt ³⁾	dv/dt	50	V/ns
Maximum diode commutation speed	di _F /dt	900	A/μs
Operating junction and storage temperature	T _j , T _{stg}	-55...+150	°C

1) Limited by T_{j,max}. Maximum Duty Cycle D = 0.50

2) Pulse width t_p limited by T_{j,max}

3) Identical low side and high side switch with identical RG

Thermal Resistance

Parameter	Symbol	Value			Unit	Test Condition
		min.	typ.	max.		
Thermal resistance, junction – case	R_{thJC}	-	0.13	0.18	°C/W	
Thermal resistance, junction – ambient	R_{thJA}	-	-	45	°C/W	

Electrical Characteristic (at $T_j = 25\text{ °C}$, unless otherwise specified)

Parameter	Symbol	Value			Unit	Test Condition
		min.	typ.	max.		

Static Characteristic

Drain-source breakdown voltage	BV_{DSS}	650	-	-	V	$V_{GS}=0V, I_D=250\mu A$
Gate threshold voltage	$V_{GS(th)}$	3.3	-	4.6	V	$V_{DS}=V_{GS}, I_D=250\mu A$
Zero gate voltage drain current	I_{DSS}	-	-	1	μA	$V_{DS}=650V, V_{GS}=0V$ $T_j=25\text{ °C}$ $T_j=150\text{ °C}$
Gate-source leakage current	I_{GSS}	-	-	± 100	nA	$V_{GS}=\pm 30V, V_{DS}=0V$
Drain-source on-state resistance	$R_{DS(on)}$	-	42	48	mΩ	$V_{GS}=10V, I_D=35A,$ $T_j=25\text{ °C}$ $T_j=150\text{ °C}$
Transconductance	g_{fs}	-	66	-	S	$V_{DS}=20V, I_D=35A$

Dynamic Characteristic

Input Capacitance	C_{iss}	-	6622	-	pF	$V_{GS}=0V, V_{DS}=100V,$ $f=1MHz$
Output Capacitance	C_{oss}	-	281	-		
Reverse Transfer Capacitance	C_{rss}	-	5.4	-		
Gate Total Charge	Q_G	-	172	-	nC	$V_{GS}=10V, V_{DS}=480V,$ $I_D=35A$
Gate-Source charge	Q_{gs}	-	46	-		
Gate-Drain charge	Q_{gd}	-	73	-		
Gate plateau voltage	$V_{plateau}$	-	6.4	-	V	
Turn-on delay time	$t_{d(on)}$	-	135	-	ns	$V_{GS}=10V, I_D=35A,$ $V_{DS}=400V, R_g=27\Omega$
Rise time	t_r	-	98	-		
Turn-off delay time	$t_{d(off)}$	-	531	-		
Fall time	t_f	-	94	-		
Gate resistance	R_{gint}	-	1.0	-	Ω	$V_{GS}=0V, V_{DS}=0V, f=1MHz$

Body Diode Characteristic

Parameter	Symbol	Value			Unit	Test Condition
		min.	typ.	max.		
Body Diode Forward Voltage	V_{SD}	0.7	0.91	1.2	V	$V_{GS}=0V, I_{SD}=35A$
Body Diode Reverse Recovery Time	t_{rr}	-	182		ns	$I_{sd}=35A$ $dI/dt=100A/us$ $V_{ds}=400V$
Body Diode Reverse Recovery Charge	Q_{rr}	-	1.2		uC	
Body Diode Reverse Recovery Peak Current	I_{rrm}	-	12.3		A	

Typical Performance Characteristics

Fig 1. Output Characteristics (Tj=25°C)

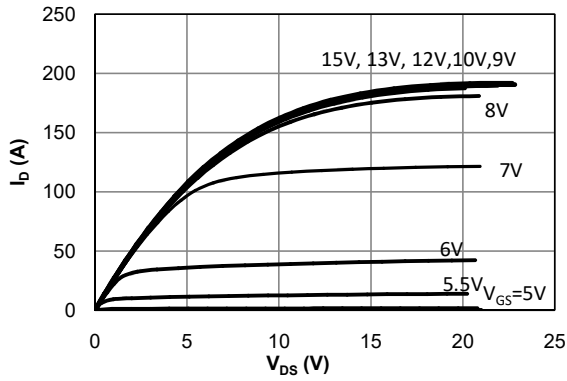

Fig 2. Output Characteristics (Tj=150°C)

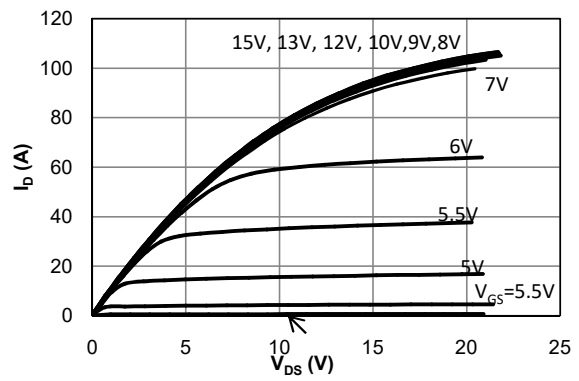

Fig 3: Transfer Characteristics

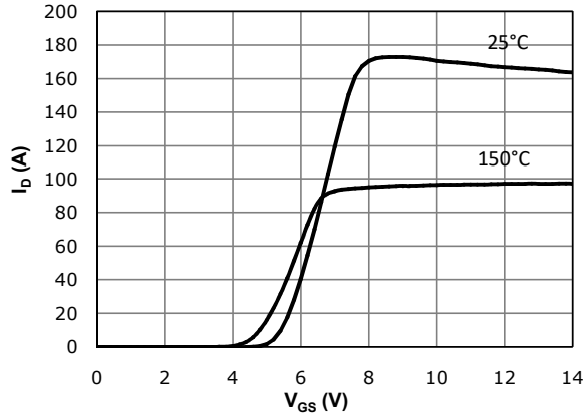

Fig 4: V_{th} Vs Tj Temperature Characteristics

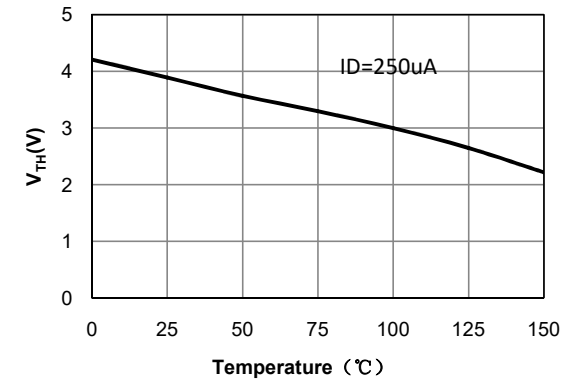

Fig 5: R_{ds(on)} Vs Ids Characteristics(Tj=25°C)

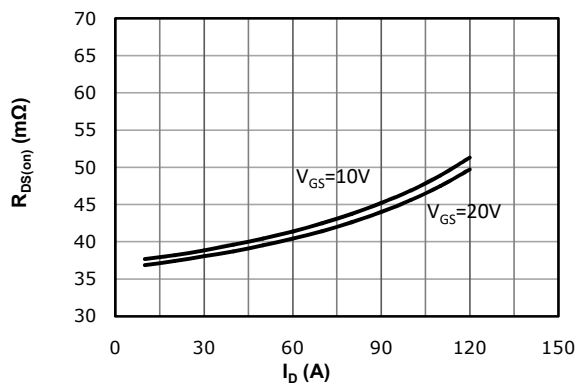

Fig 6: R_{ds(on)} vs. Temperature

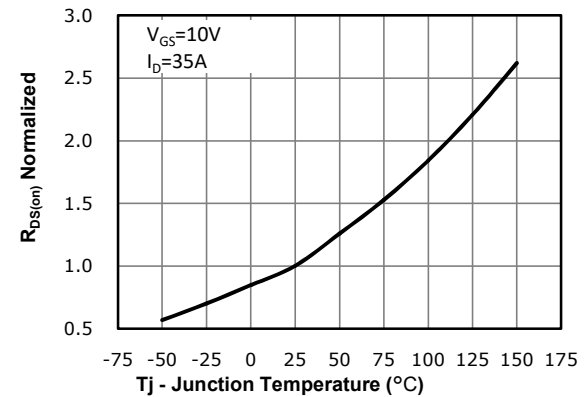

Fig 7: BVDSS vs. Temperature

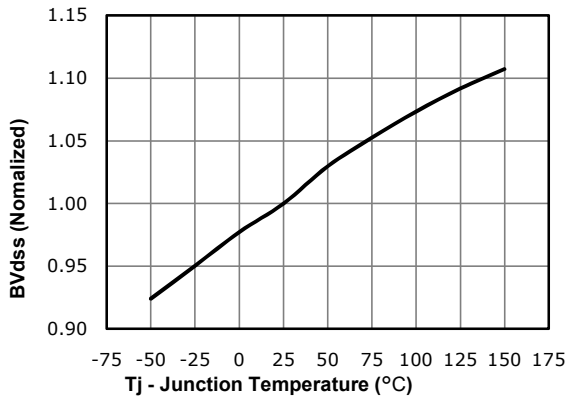

Fig 8: Rds(on) vs Gate Voltage

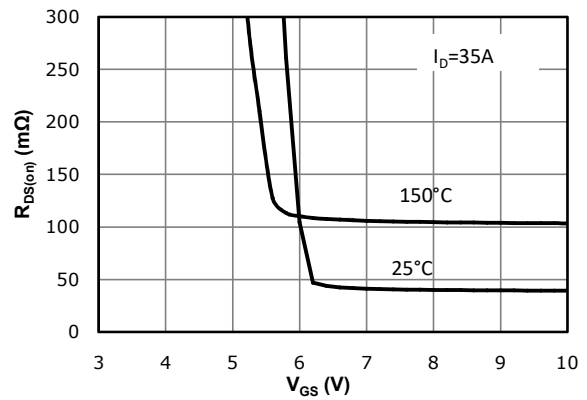

Fig 9: Body-diode Forward Characteristics

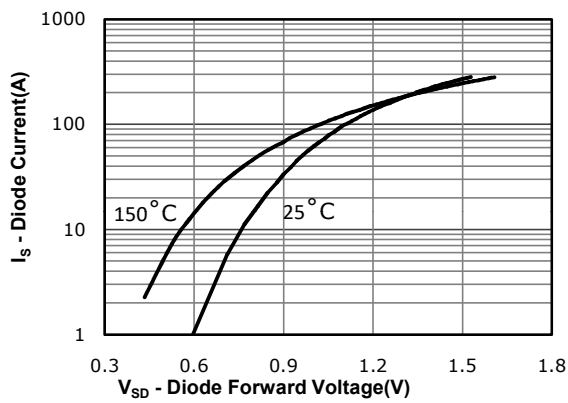

Fig 10: Gate Charge Characteristics

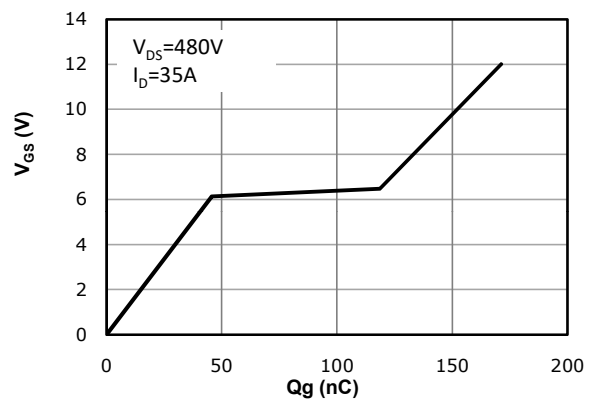

Fig 11: Capacitance Characteristics

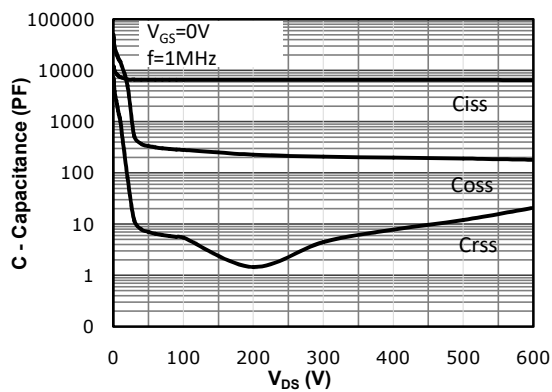

Fig 12: Safe Operating Area

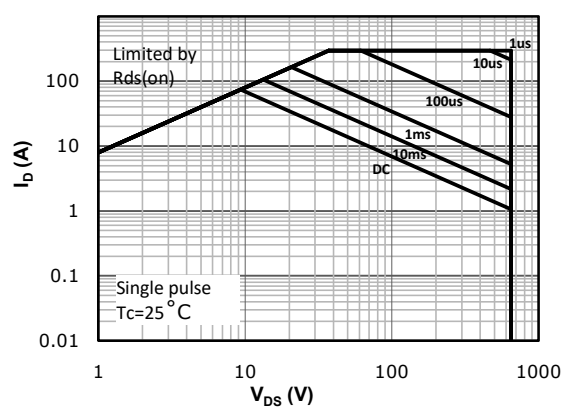
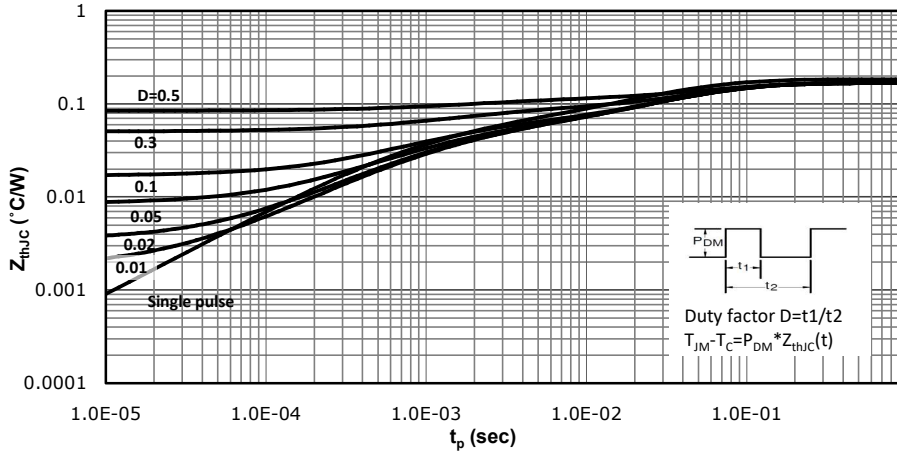

Fig 13: Max. Thermal Junction Temperature

Fig 13: Max. Transient Thermal Impedance



Test Circuit & Waveform

Gate Charge Test Circuit & Waveform

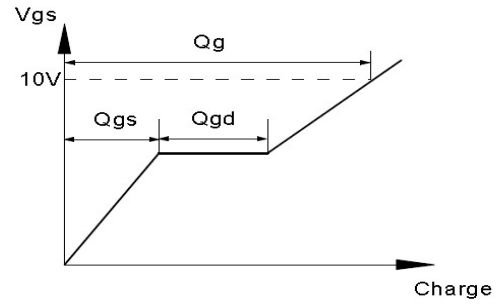
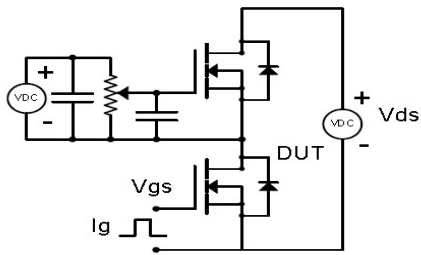

Resistive Switching Test Circuit & Waveforms

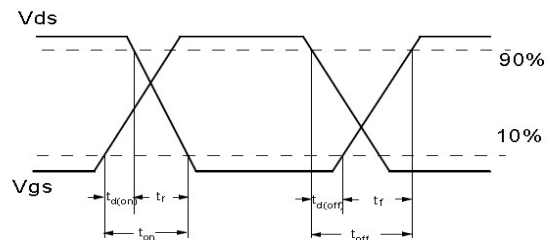
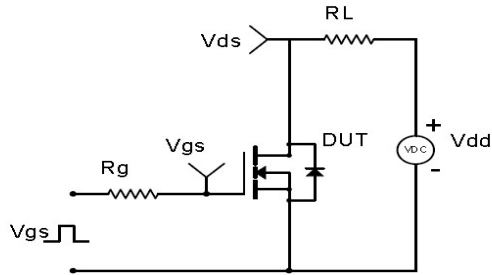

Unclamped Inductive Switching (UIS) Test Circuit & Waveforms

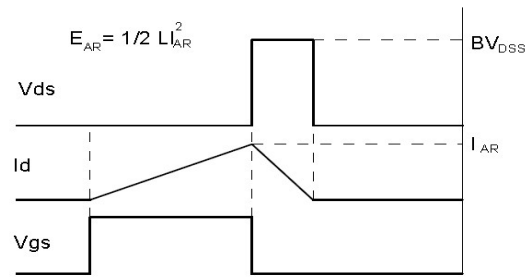
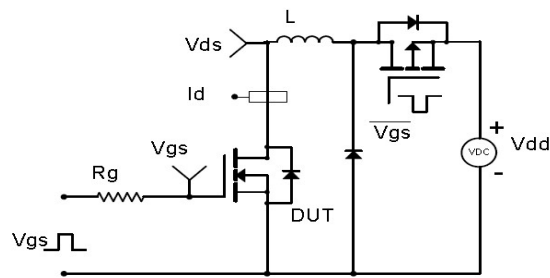

Diode Recovery Test Circuit & Waveforms

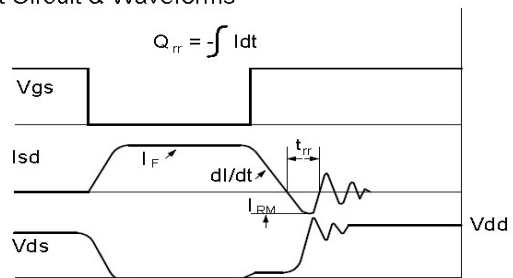
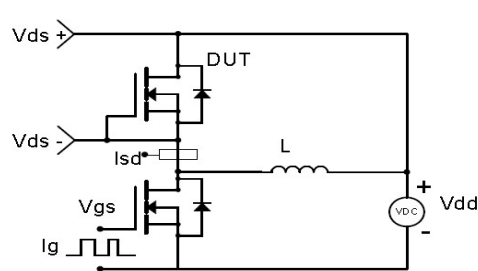

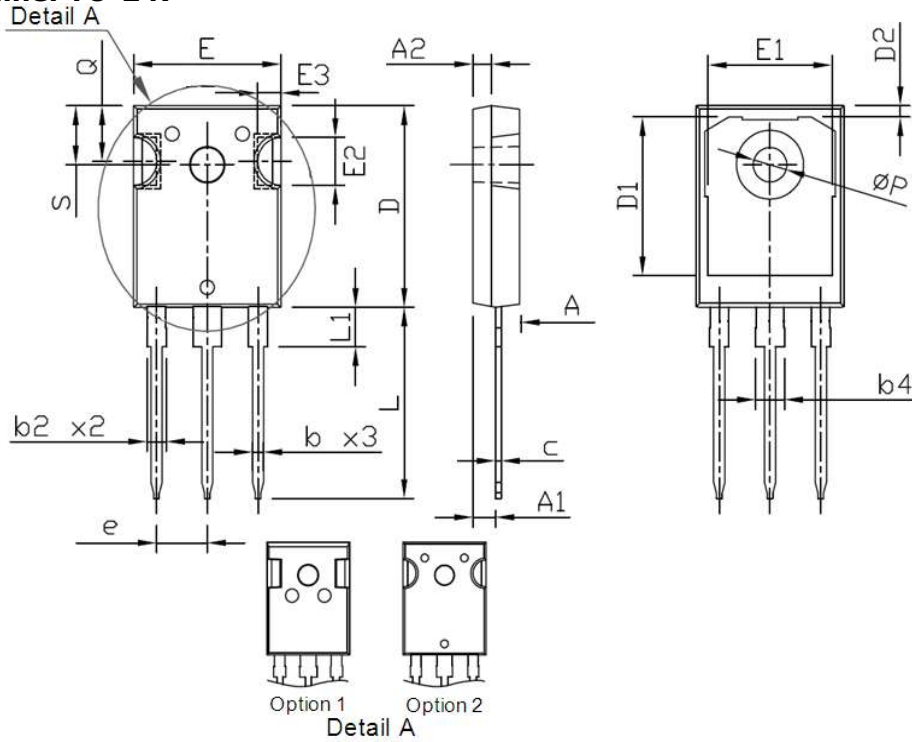
Package Outline: TO-247

Symbol	Dimensions In Millimeters		Dimensions In Inches	
	Min.	Max.	Min.	Max.
A	4.70	5.30	0.185	0.209
A1	2.20	2.60	0.087	0.102
A2	1.50	2.49	0.059	0.098
b	1.04	1.33	0.041	0.052
b2	1.90	2.41	0.075	0.095
b4	2.87	3.43	0.113	0.135
c	0.55	0.70	0.022	0.028
D	20.70	21.30	0.815	0.839
D1	16.25	17.65	0.640	0.695
D2	0.51	1.40	0.020	0.055
e	5.44 BSC.		0.214 BSC.	
E	15.50	16.30	0.610	0.642
E1	13.08	14.16	0.515	0.557
E2	3.80	5.49	0.150	0.216
E3	1.00	2.75	0.039	0.108
L	19.72	20.32	0.776	0.800
L1	3.85	4.50	0.152	0.177
Q	5.25	6.25	0.207	0.246
P	3.50	3.70	0.138	0.146
S	6.04	6.30	0.238	0.248

Marking



NOTE:

XBBAAAAY

X —Assembly location code
BB —Fab code
AAAA —Lot code
Y —Bin code

Revision History

Revision	Date	Major changes
1.0	2023/5/15	Release of First version

Disclaimer

Unless otherwise specified in the datasheet, the product is designed and qualified as a standard commercial product and is not intended for use in applications that require extraordinary levels of quality and reliability, such as automotive, aviation/aerospace and life-support devices or systems.

Any and all semiconductor products have certain probability to fail or malfunction, which may result in personal injury, death or property damage. Customer are solely responsible for providing adequate safe measures when design their systems.

CRM(CQ) reserves the right to improve product design, function and reliability without notice.