

**Features**

- CRM(CQ) Super\_Junction technology
- Much lower Ron\*A performance for On-state efficiency
- Much lower FOM for fast switching efficiency

**Applications**

- LED/LCD/PDP TV and monitor Lighting
- Solar/Renewable/UPS-Micro Inverter System
- Charger
- Power Supply

**Product Summary**

V <sub>DS</sub>	650V
R <sub>DS(on)_typ</sub>	90mΩ
I <sub>D</sub>	38A

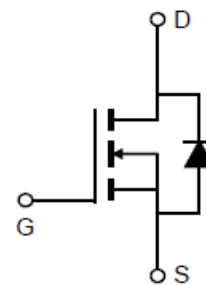
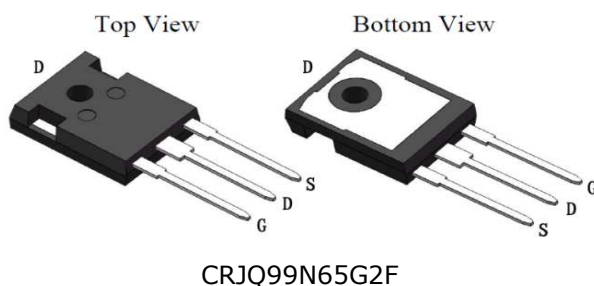
**100% DVDS Tested**
**100% Avalanche Tested**

**Package Marking and Ordering Information**

Part #	Marking	Package	Packing	Reel Size	Tape Width	Qty
CRJQ99N65G2F	-	TO-247	Tube	N/A	N/A	25pcs

**Absolute Maximum Ratings**

Parameter	Symbol	Value	Unit
Drain-source voltage	V <sub>DS</sub>	650	V
Continuous drain current T <sub>C</sub> = 25°C T <sub>C</sub> = 100°C	I <sub>D</sub>	38 30	A
Pulsed drain current (T <sub>C</sub> = 25°C, t <sub>p</sub> limited by T <sub>jmax</sub> )	I <sub>D pulse</sub>	152	A
Avalanche energy, single pulse (L=60mH, R <sub>g</sub> =30Ω)	E <sub>AS</sub>	480	mJ
Gate-Source voltage	V <sub>GS</sub>	±30	V
Power dissipation (T <sub>C</sub> = 25°C)	P <sub>tot</sub>	558	W
Operating junction and storage temperature	T <sub>j</sub> , T <sub>stg</sub>	-55...+150	°C

**Thermal Resistance**

Parameter	Symbol	Value			Unit	Test Condition
		min.	typ.	max.		
Thermal resistance, junction – case. Max	RthJC	-	0.16	0.22	°C/W	
Thermal resistance, junction – ambient. Max	RthJA	-	-	48	°C/W	

**Electrical Characteristic (at Tj = 25 °C, unless otherwise specified)**

Parameter	Symbol	Value			Unit	Test Condition
		min.	typ.	max.		

**Static Characteristic**

Drain-source breakdown voltage	BV <sub>DSS</sub>	650	-	-	V	V <sub>GS</sub> =0V, I <sub>D</sub> =250uA
Gate threshold voltage	V <sub>GS(th)</sub>	3.4	-	4.8	V	V <sub>DS</sub> =V <sub>GS</sub> , I <sub>D</sub> =250uA
Zero gate voltage drain current	I <sub>DSS</sub>	-	-	5	μA	V <sub>DS</sub> =650V, V <sub>GS</sub> =0V
		-	800	-		T <sub>C</sub> =25°C
Gate-source leakage current	I <sub>GSS</sub>	-	-	±100	nA	V <sub>GS</sub> =±30V, V <sub>DS</sub> =0V
Drain-source on-state resistance	R <sub>DS(on)</sub>	-	90	99	mΩ	V <sub>GS</sub> =10V, I <sub>D</sub> =17A,
		-	235	-		T <sub>C</sub> =25°C
Transconductance	g <sub>fs</sub>	-	18.8	-	S	V <sub>DS</sub> =20V, I <sub>D</sub> =17A

**Dynamic Characteristic**

Input Capacitance	C <sub>iSS</sub>	-	2040	-	pF	V <sub>GS</sub> =0V, V <sub>DS</sub> =100V, f=1MHz
Output Capacitance	C <sub>oss</sub>	-	130	-		
Reverse Transfer Capacitance	C <sub>rSS</sub>	-	37	-		
Gate Total Charge	Q <sub>G</sub>	-	57	-	nC	V <sub>GS</sub> =10V, V <sub>DS</sub> =480V, I <sub>D</sub> =17A, f=1MHz
Gate-Source charge	Q <sub>gs</sub>	-	19.5	-		
Gate-Drain charge	Q <sub>gd</sub>	-	30	-		
Turn-on delay time	t <sub>d(on)</sub>	-	63.4	-	ns	T <sub>J</sub> =25°C, V <sub>GS</sub> =10V, I <sub>D</sub> =17A, V <sub>DS</sub> =400V, R <sub>g</sub> =27Ω
Rise time	t <sub>r</sub>	-	106	-		
Turn-off delay time	t <sub>d(off)</sub>	-	132	-		
Fall time	t <sub>f</sub>	-	30	-		
Gate resistance	R <sub>G</sub>	-	0.9	-	Ω	V <sub>GS</sub> =0V, V <sub>DS</sub> =0V, f=1MHz

**Body Diode Characteristic**

Parameter	Symbol	Value			Unit	Test Condition
		min.	typ.	max.		
Body Diode Forward Voltage	$V_{SD}$	0.7	0.9	1.2	V	$V_{GS}=0V, I_{SD}=17A$
Body Diode Reverse Recovery Time	$t_{rr}$	-	140	-	ns	$I_{sd}=17A$ $dI/dt=100A/us, V_{ds}=400V$
Body Diode Reverse Recovery Charge	$Q_{rr}$	-	0.89	-	uC	

## Typical Performance Characteristics

Fig 1. Output Characteristics (Tj=25°C)

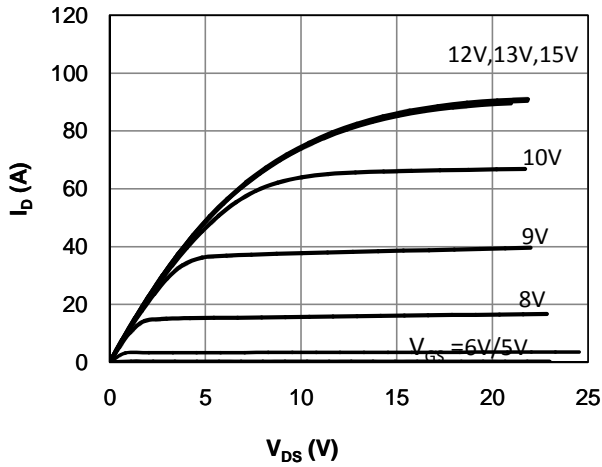

Fig 2. Output Characteristics (Tj=150°C)

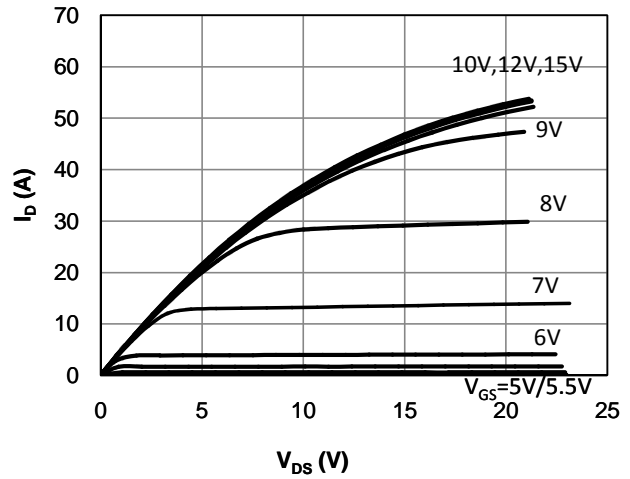

Fig 3: Transfer Characteristics

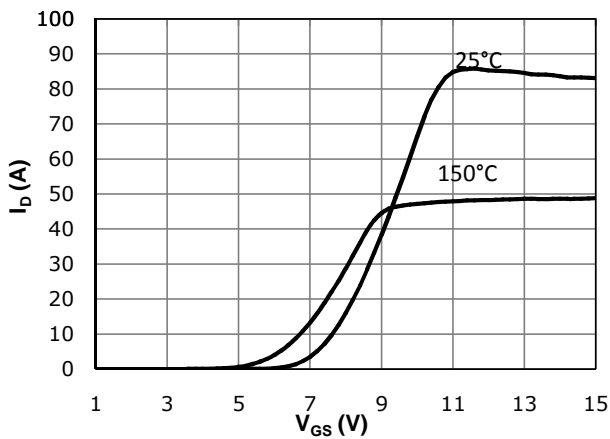

Fig 4: V<sub>TH</sub> Vs Tj Temperature Characteristics

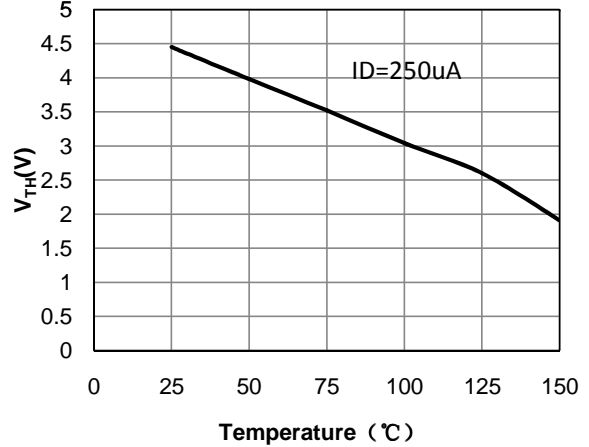

Fig 5: R<sub>DS(on)</sub> Vs Ids Characteristics (Tc=25°C)

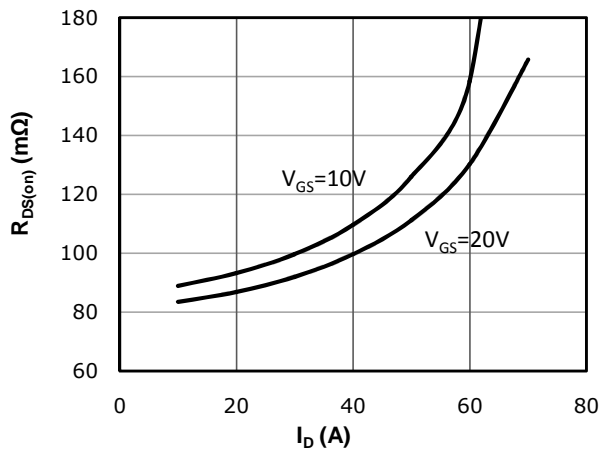
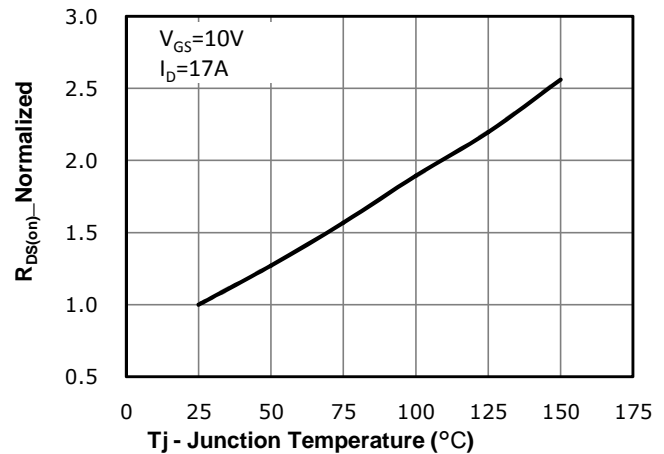
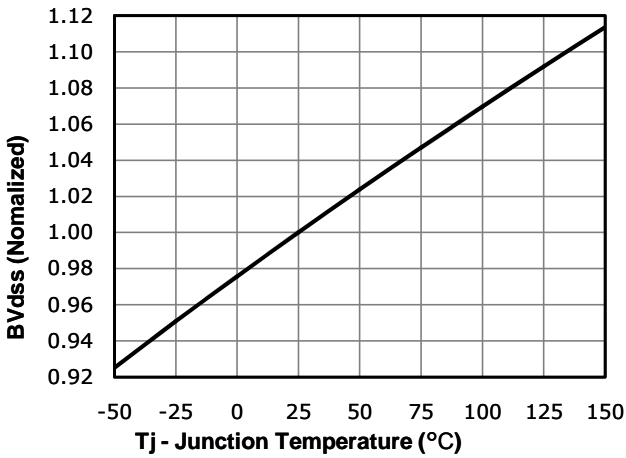

Fig 6: R<sub>DS(on)</sub> vs. Temperature



**Fig 7: BVdss vs. Temperature**



**Fig 8: Rds(on) vs Gate Voltage**

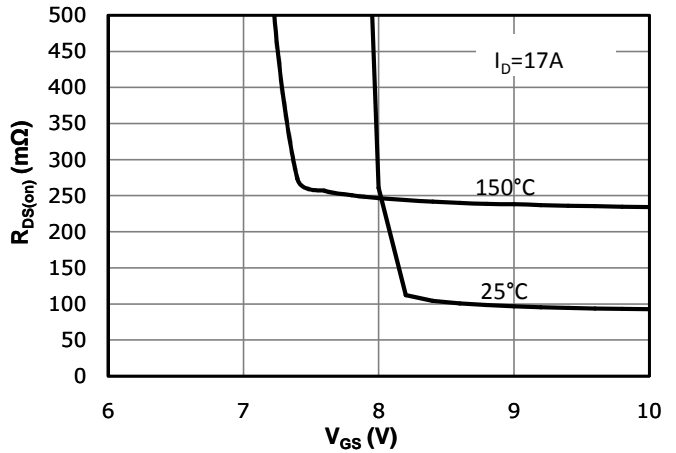

**Fig 9: Body-diode Forward Characteristics**

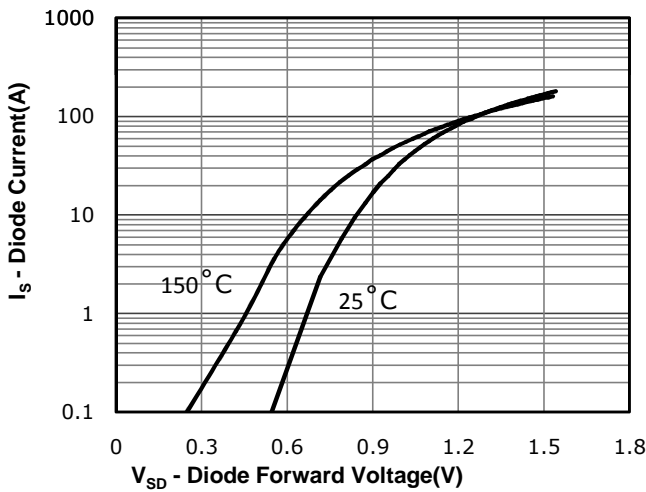

**Fig 10: Gate Charge Characteristics**

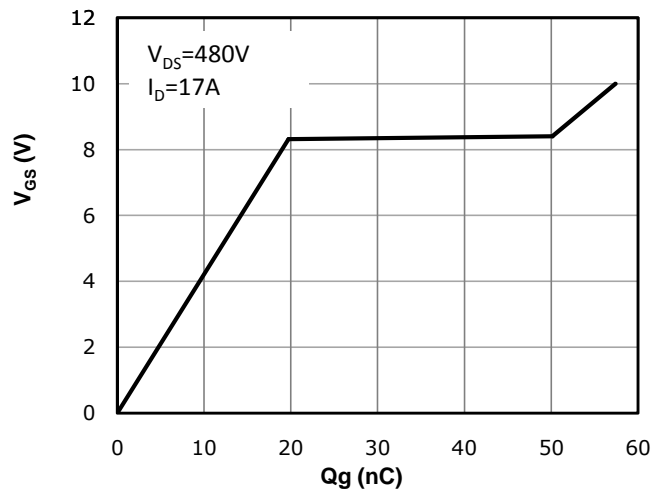

**Fig 11: Capacitance Characteristics**

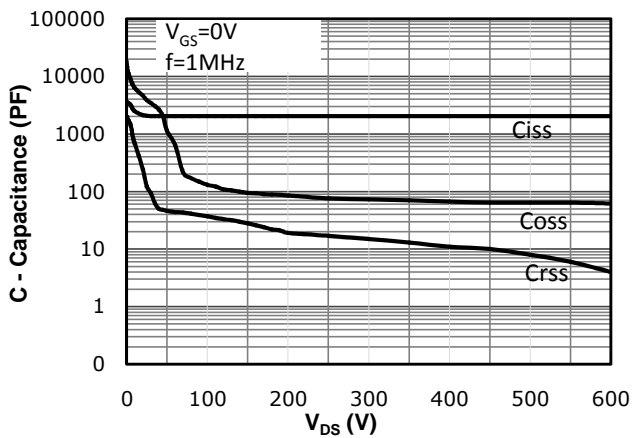

**Fig 12: Safe Operating Area**

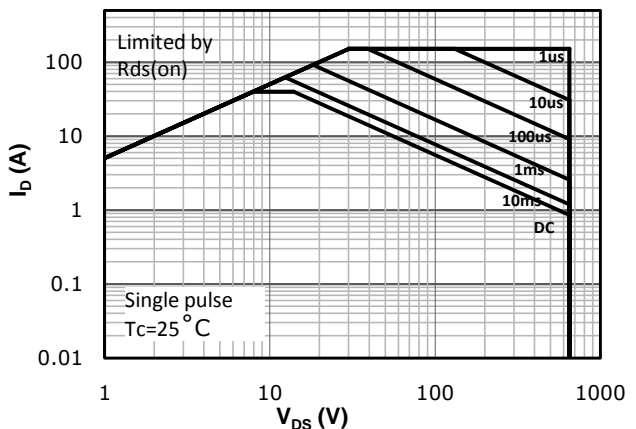
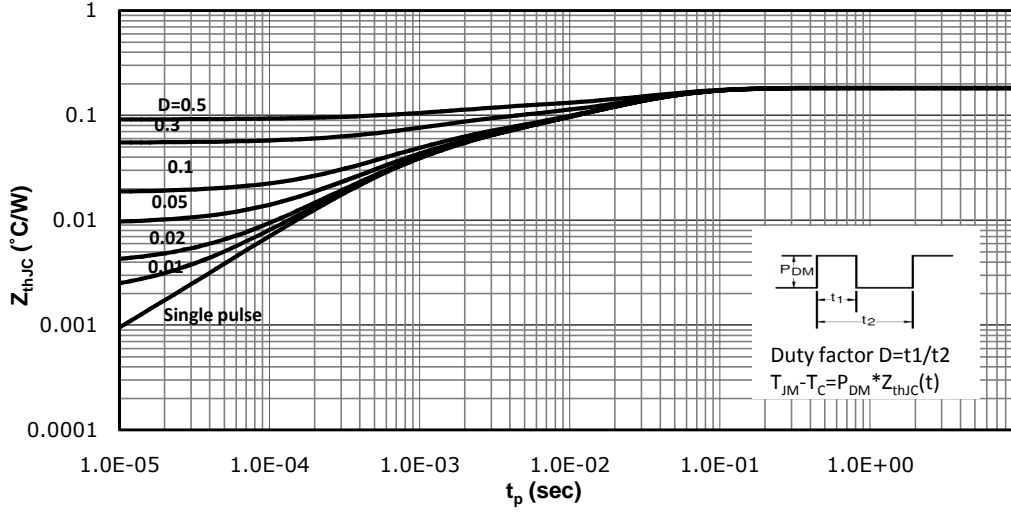
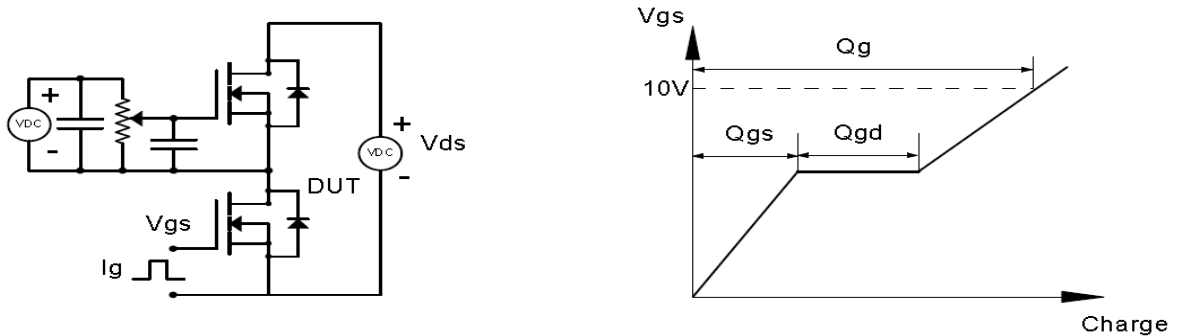

Fig 13: Max. Transient Thermal Impedance



## Test Circuit & Waveform

Gate Charge Test Circuit & Waveform



Resistive Switching Test Circuit & Waveforms

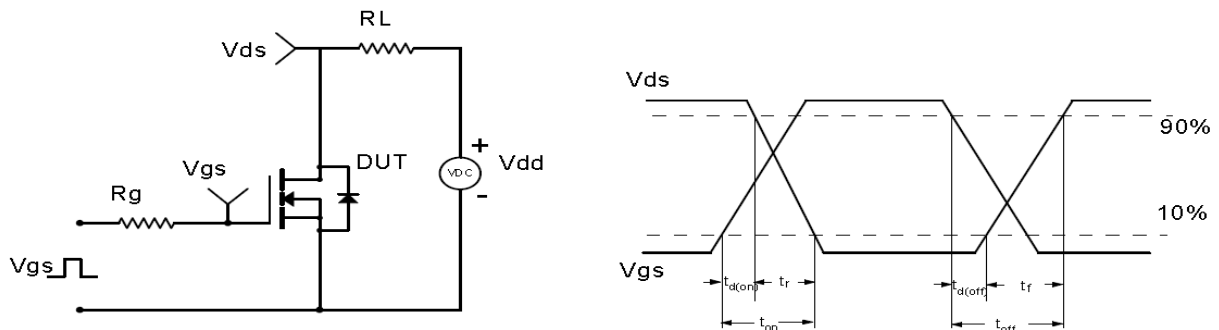

Unclamped Inductive Switching (UIS) Test Circuit & Waveforms

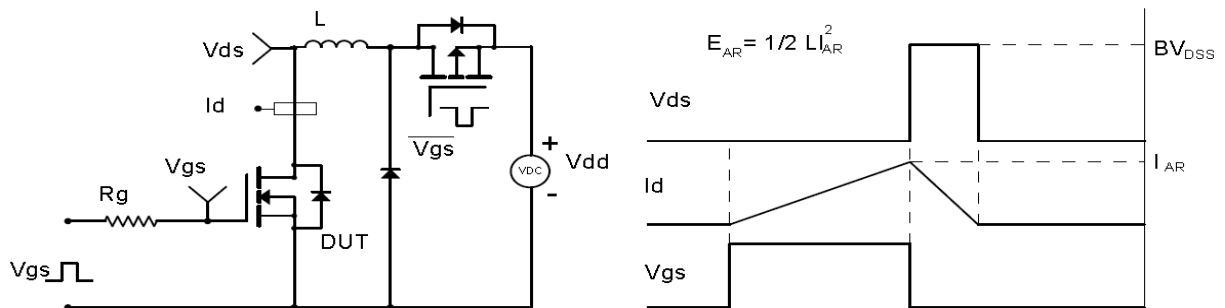

Diode Recovery Test Circuit & Waveforms

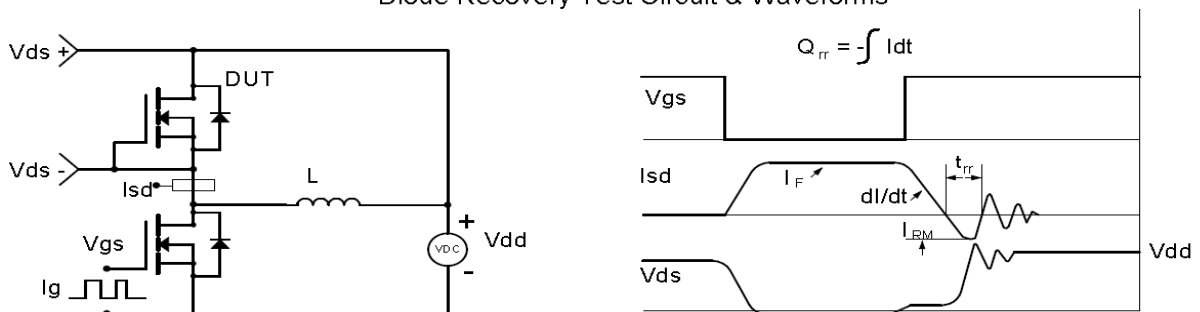

**Package Outline: TO-247**

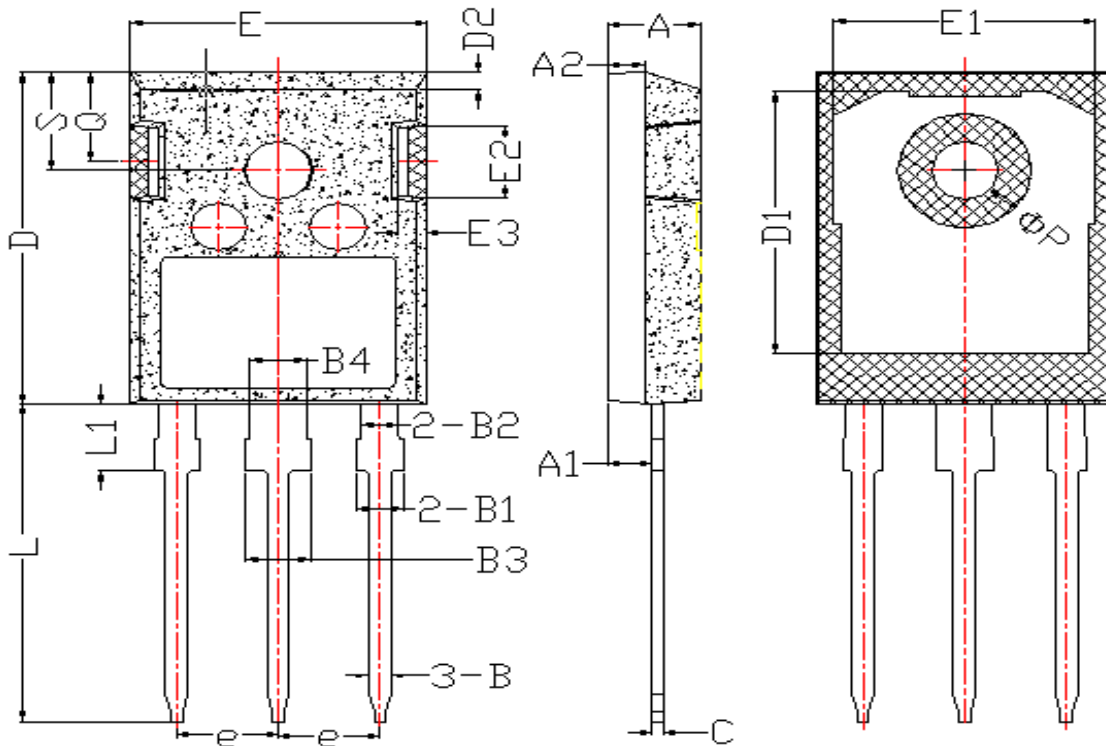

Symbol	Dimensions In Millimeters		Dimensions In Inches	
	Min.	Max.	Min.	Max.
A	4.60	5.20	0.181	0.205
A1	2.20	2.60	0.087	0.102
A2	1.80	2.20	0.071	0.087
B	0.90	1.40	0.035	0.055
B1	1.75	2.35	0.069	0.093
B2	1.75	2.15	0.069	0.085
B3	2.80	3.35	0.110	0.132
B4	2.80	3.15	0.110	0.124
C	0.50	0.70	0.020	0.028
D	20.60	21.30	0.811	0.839
D1	16.00	18.00	0.630	0.709
D2	0.90	1.40	0.035	0.055
E	15.50	16.10	0.610	0.634
E1	13.00	14.70	0.512	0.579
E2	3.80	5.30	0.150	0.209
E3	0.80	2.60	0.031	0.102
e	5.20	5.70	0.205	0.224
L	19.00	20.50	0.748	0.807
L1	3.90	4.60	0.154	0.181
ΦP	3.30	3.70	0.130	0.146
Q	5.20	6.00	0.205	0.236
S	5.80	6.60	0.228	0.260



## Marking



**NOTE:**

NXBBAAAAY

X —Assembly location code

BB —Fab code

AAAA —Lot code

Y —Bin code

## Revision History

Revision	Date	Major changes
1.0	2020-8-20	Draft version

## Disclaimer

Unless otherwise specified in the datasheet, the product is designed and qualified as a standard commercial product and is not intended for use in applications that require extraordinary levels of quality and reliability, such as automotive, aviation/aerospace and life-support devices or systems.

Any and all semiconductor products have certain probability to fail or malfunction, which may result in personal injury, death or property damage. Customer are solely responsible for providing adequate safe measures when design their systems.

CRM(CQ) reserves the right to improve product design, function and reliability without notice.