

Features

- CRM(CQ) Super_Junction technology
- Much lower Ron*A performance for On-state efficiency
- Better efficiency due to very low FOM
- Ultra-fast body diode

Product Summary

$V_{DS,min}$	600V
$R_{DS(on),typ}$	70mΩ
I_D	34A

Applications

- LED/LCD/PDP TV and monitor Lighting
- Solar/Renewable/UPS-Micro Inverter System
- Charger
- Power Supply

100% DVDS Tested
100% Avalanche Tested

Top view

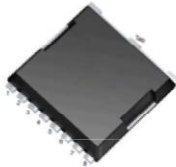

Bottom view

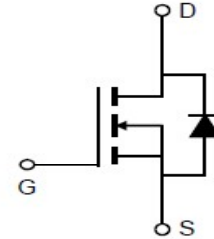
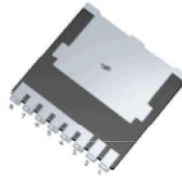
Package Marking and Ordering Information

Part #	Marking	Package	Packing	Reel Size	Tape Width	Qty
CRJZ74N60G2BF	JZ74N60G2BF	TOLL	Tape&Reel	N/A	N/A	2000pcs

Absolute Maximum Ratings

Parameter	Symbol	Value	Unit
Drain-source voltage	V_{DS}	600	V
Continuous drain current ¹⁾ $T_C = 25^\circ\text{C}$ $T_C = 100^\circ\text{C}$	I_D	34 21	A
Pulsed drain current ²⁾ ($T_C = 25^\circ\text{C}$, t_p limited by $T_{j,max}$)	$I_{D,pulse}$	101	A
Avalanche energy, single pulse (L=30mH)	E_{AS}	520	mJ
MOSFET dv/dt ruggedness	dv/dt	50	V/ns
Gate-Source voltage	V_{GS}	±30	V
Power dissipation ($T_C = 25^\circ\text{C}$)	P_{tot}	237	W
Continuous diode forward current ($T_C = 25^\circ\text{C}$)	I_S	34	A
Diode pulse current ²⁾ ($T_C = 25^\circ\text{C}$)	$I_{S,pulse}$	101	A
Recovery diode dv/dt ³⁾	dv/dt	50	V/ns
Operating junction and storage temperature	T_j, T_{stg}	-55...+150	°C

 1) Limited by $T_{j,max}$. Maximum Duty Cycle $D = 0.50$

 2) Pulse width t_p limited by $T_{j,max}$

 3) Identical low side and high side switch with identical R_g

Thermal Resistance

Parameter	Symbol	Value			Unit	Test Condition
		min.	typ.	max.		
Thermal resistance, junction – case	R_{thJC}	-	0.38	0.53	°C/W	
Thermal resistance, junction – ambient	R_{thJA}	-	-	53	°C/W	

Electrical Characteristic (at $T_j = 25\text{ }^\circ\text{C}$, unless otherwise specified)

Parameter	Symbol	Value			Unit	Test Condition
		min.	typ.	max.		

Static Characteristic

Drain-source breakdown voltage	BV_{DSS}	600	-	-	V	$V_{GS}=0V, I_D=250\mu A$
Gate threshold voltage	$V_{GS(th)}$	3.2	-	4.6	V	$V_{DS}=V_{GS}, I_D=250\mu A$
Zero gate voltage drain current	I_{DSS}	-	-	5	μA	$V_{DS}=600V, V_{GS}=0V$ $T_j=25^\circ C$
		-	500	-		$T_j=150^\circ C$
Gate-source leakage current	I_{GSS}	-	-	± 100	nA	$V_{GS}=\pm 30V, V_{DS}=0V$
Drain-source on-state resistance	$R_{DS(on)}$	-	70	77	mΩ	$V_{GS}=10V, I_D=23A,$ $T_j=25^\circ C$
		-	180	-		$T_j=150^\circ C$
Transconductance	g_{fs}	-	30	-	S	$V_{DS}=20V, I_D=23A$

Dynamic Characteristic

Input Capacitance	C_{iss}	-	2200	-	pF	$V_{GS}=0V, V_{DS}=100V,$ $f=1MHz$
Output Capacitance	C_{oss}	-	137	-		
Reverse Transfer Capacitance	C_{rss}	-	3.2	-		
Gate Total Charge	Q_g	-	84	-	nC	$V_{GS}=10V, V_{DS}=480V,$ $I_D=23A$
Gate-Source charge	Q_{gs}	-	19	-		
Gate-Drain charge	Q_{gd}	-	53	-		
Gate plateau voltage	$V_{plateau}$	-	7.5	-	V	
Turn-on delay time	$t_{d(on)}$	-	63	-	ns	$V_{GS}=10V, I_D=23A,$ $V_{DS}=400V, R_g=27\Omega$
Rise time	t_r	-	107	-		
Turn-off delay time	$t_{d(off)}$	-	244	-		
Fall time	t_f	-	103	-		
Gate resistance	$R_{g,int}$	-	1.2	-	Ω	$f=1MHz$

Body Diode Characteristic

Parameter	Symbol	Value			Unit	Test Condition
		min.	typ.	max.		
Body Diode Forward Voltage	V_{SD}	0.7	0.91	1.1	V	$V_{GS}=0V, I_{SD}=23A$
Body Diode Reverse Recovery Time	t_{rr}	-	125	-	ns	$I_{SD}=23A$ $di_f/dt=100A/\mu s$
Body Diode Reverse Recovery Charge	Q_{rr}	-	0.9	-	μC	$V_{DS}=400V$

Typical Performance Characteristics

Fig 1. Output Characteristics ($T_j=25^\circ\text{C}$)

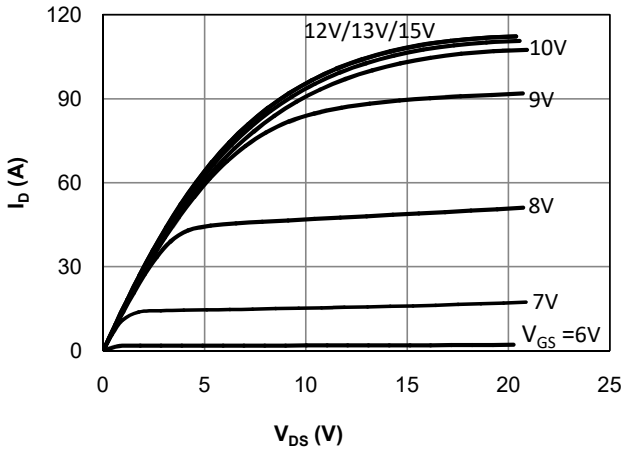

Fig 2. Output Characteristics ($T_j=150^\circ\text{C}$)

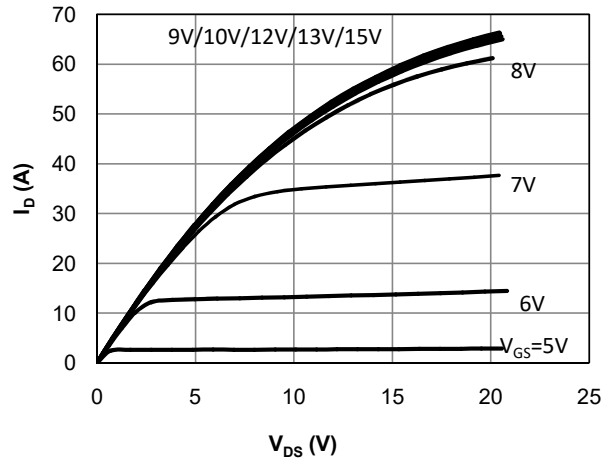

Fig 3: Transfer Characteristics

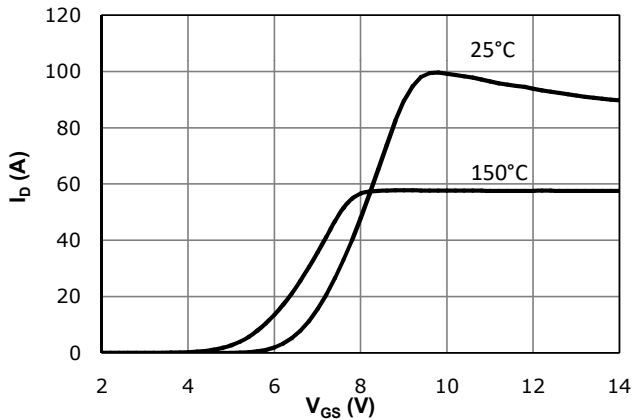

Fig 4: V_{TH} vs. T_j Temperature Characteristics

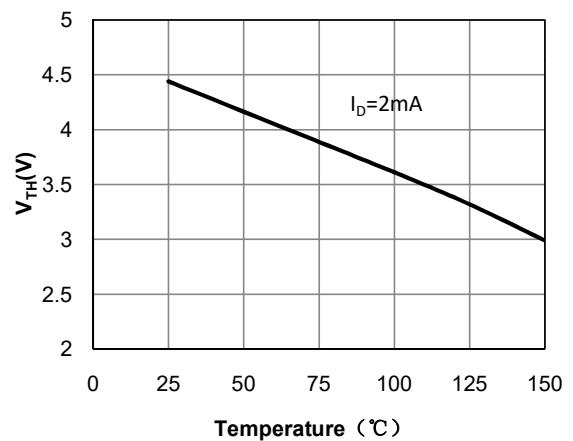

Fig 5: $R_{DS(on)}$ vs. I_{DS} Characteristics ($T_j=25^\circ\text{C}$)

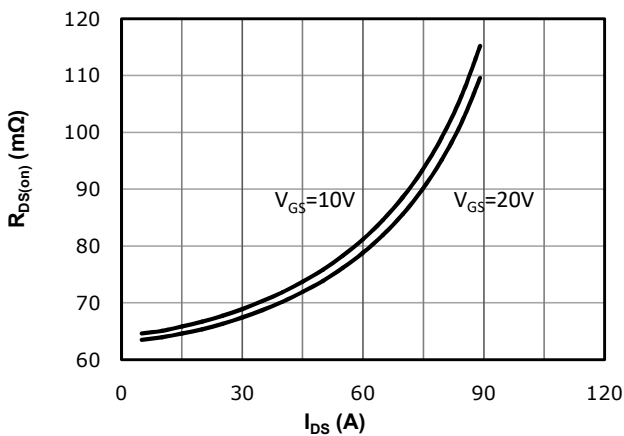

Fig 6: $R_{DS(on)}$ vs. Temperature

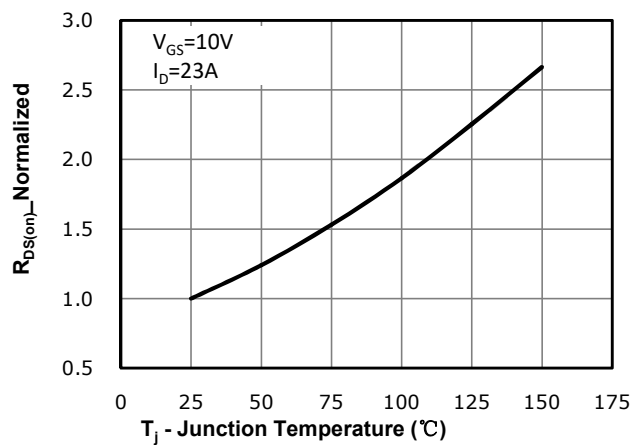

Fig 7: BV_{DSS} vs. Temperature

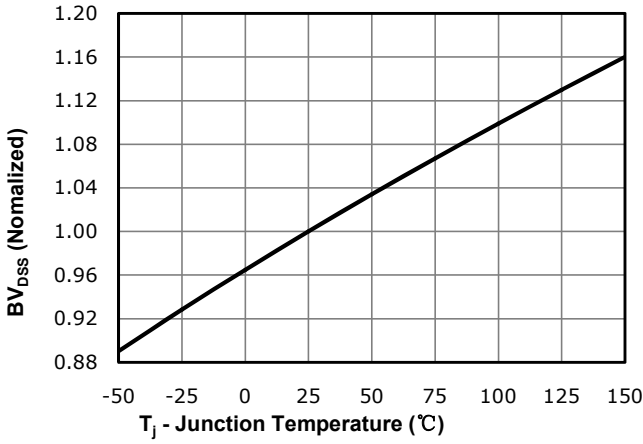

Fig 8: $R_{DS(on)}$ vs. Gate Voltage

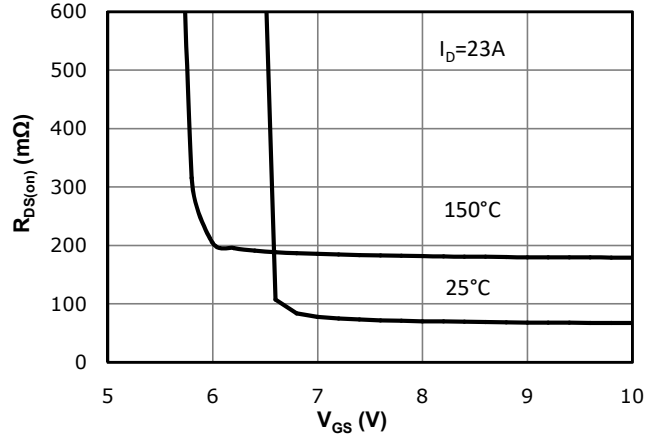

Fig 9: Body-diode Forward Characteristics

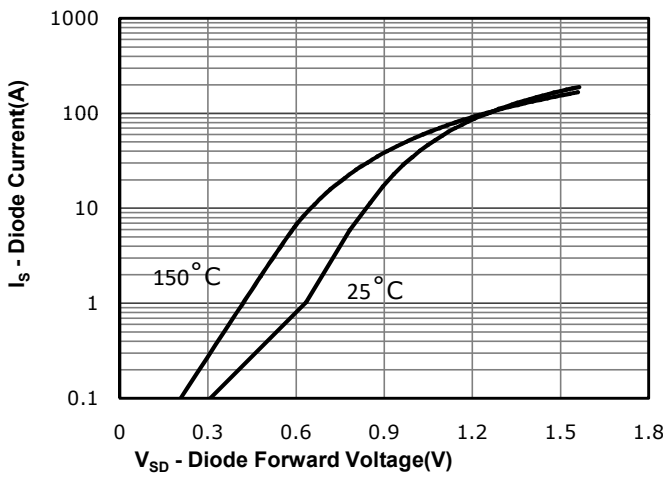

Fig 10: Gate Charge Characteristics

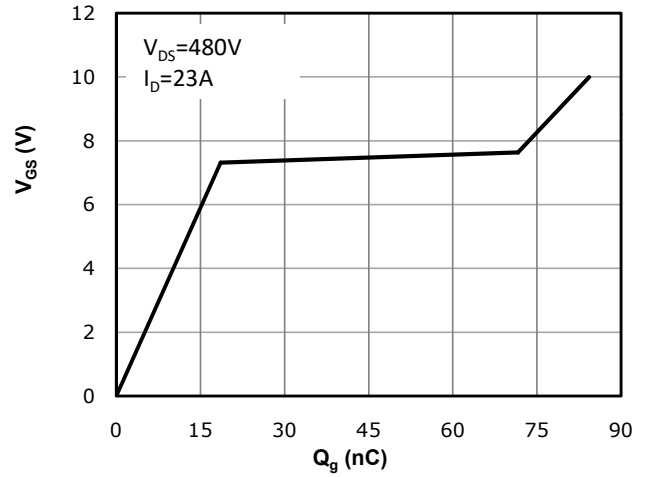

Fig 11: Capacitance Characteristics

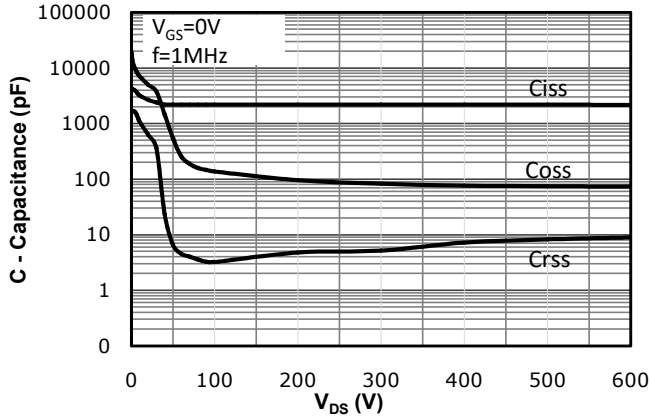

Fig 12: Safe Operating Area

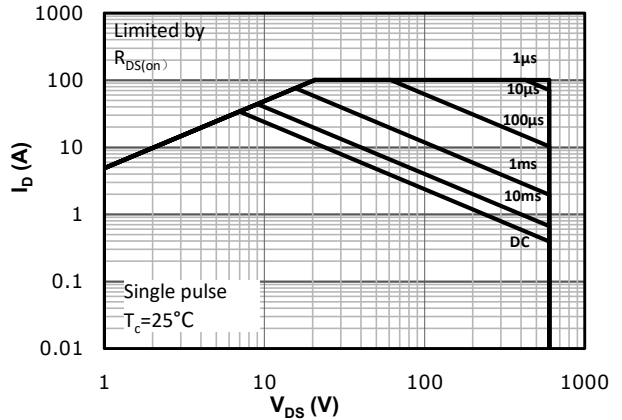
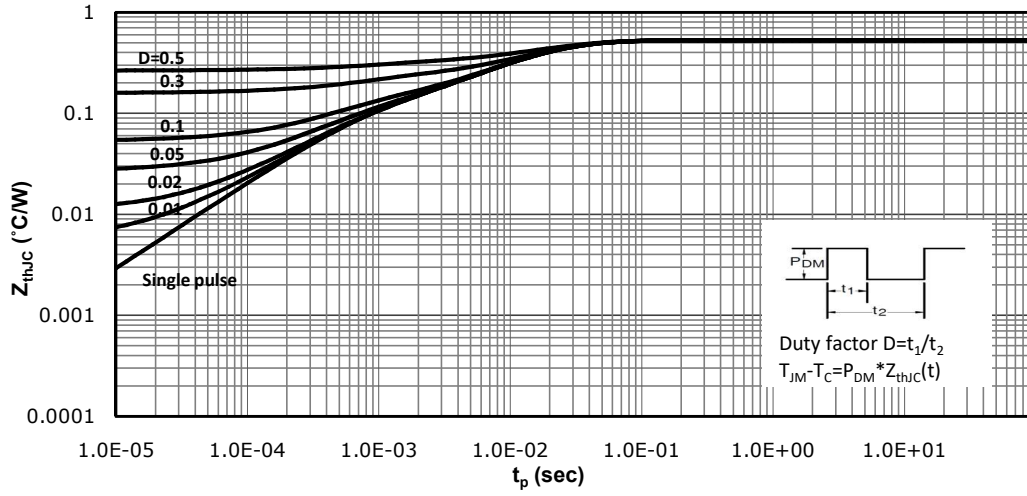
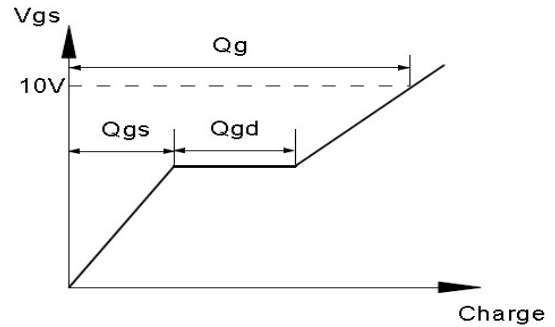
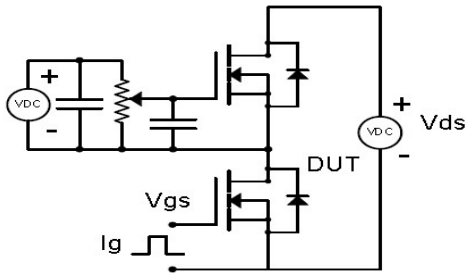

Fig 13: Max. Transient Thermal Impedance



Test Circuit & Waveform

Gate Charge Test Circuit & Waveform



Resistive Switching Test Circuit & Waveforms

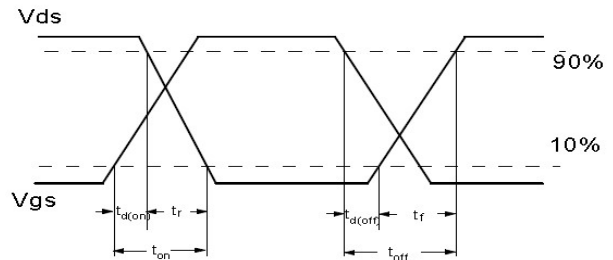
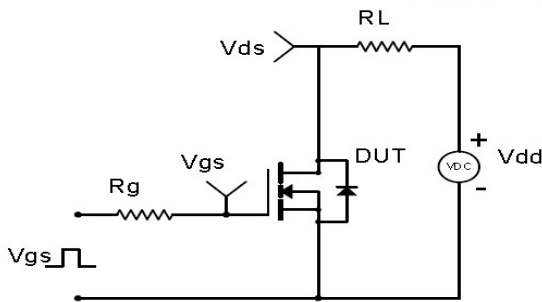

Unclamped Inductive Switching (UIS) Test Circuit & Waveforms

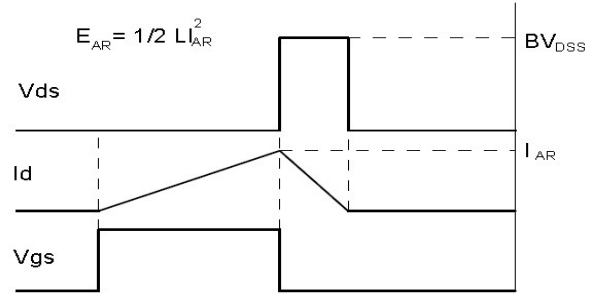
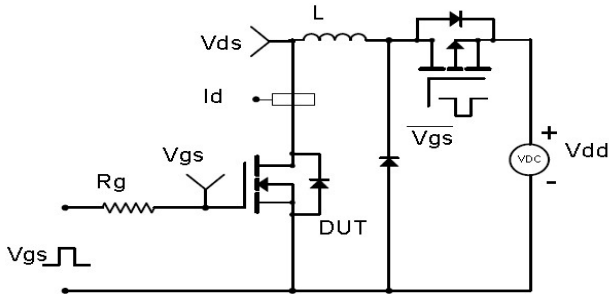

Diode Recovery Test Circuit & Waveforms

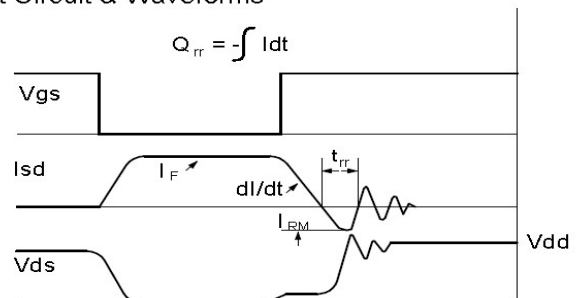
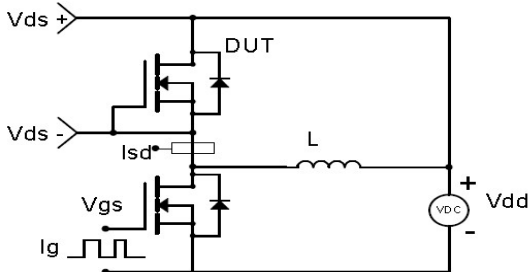

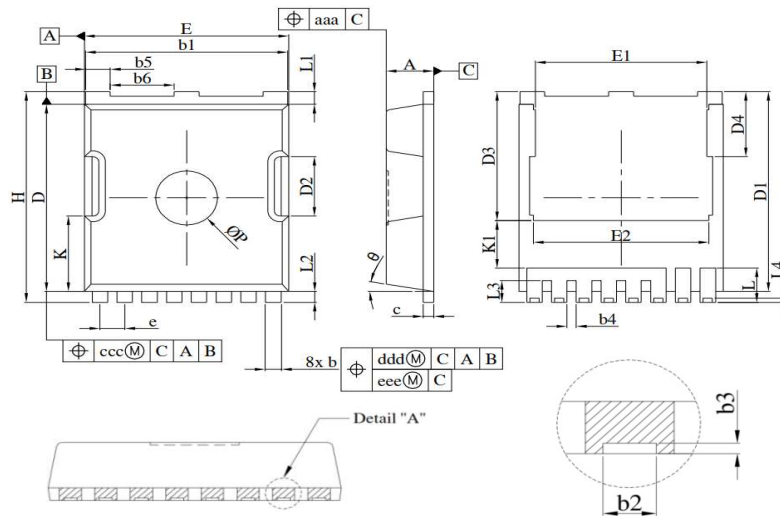
Package Outline: TOLL

Symbol	Dimensions In Millimeters		Dimensions In Inches	
	Min.	Max.	Min.	Max.
A	2.20	2.40	0.087	0.094
b	0.70	0.90	0.028	0.035
b1	9.70	9.90	0.382	0.390
b2	0.36	0.55	0.014	0.022
b3	0.05	0.35	0.002	0.014
b4	0.30	0.50	0.012	0.020
b5	1.10	1.30	0.043	0.051
b6	3.00	3.20	0.118	0.126
c	0.40	0.60	0.016	0.024
D	10.28	10.55	0.405	0.415
D1	10.98	11.18	0.432	0.440
D2	3.20	3.40	0.126	0.134
D3	7.00	7.30	0.276	0.287
D4	3.44	3.74	0.135	0.147
e	1.10	1.30	0.043	0.051
E	9.80	10.00	0.386	0.394
E1	8.20	8.40	0.323	0.331
E2	8.35	8.65	0.329	0.341
H	11.50	11.85	0.453	0.467
K	4.08	4.28	0.161	0.169
K1	2.45	---	0.096	---
L	1.60	2.10	0.063	0.083
L1	0.50	0.90	0.020	0.035
L2	0.50	0.70	0.020	0.028
L3	1.00	1.30	0.039	0.051
L4	0.13	0.33	0.005	0.013
P	2.85	3.15	0.112	0.124
theta	10°REF			
aaa	0.20		0.008	
ccc	0.20		0.008	
ddd	0.25		0.010	
eee	0.20		0.008	



NOTE:

NXBBAAAA

N —WB code (Usually omitted)

X —Assembly location code

BB —Fab code

AAAA —Lot code



Revision History

Revision	Date	Major changes
1.0	2023/12/25	First version

Disclaimer

Unless otherwise specified in the datasheet, the product is designed and qualified as a standard commercial product and is not intended for use in applications that require extraordinary levels of quality and reliability, such as automotive, aviation/aerospace and life-support devices or systems.

Any and all semiconductor products have certain probability to fail or malfunction, which may result in personal injury, death or property damage. Customer are solely responsible for providing adequate safe measures when design their systems.

CRM(CQ) reserves the right to improve product design, function and reliability without notice.