

Description

CRM50TA06E1 is 3-phase Integrated Power Modules (IPM) designed for advanced appliance motor drive applications such as energy efficient fans and pumps. This module Integrated 6 fast recovery MOSFETs and 3 high voltage gate drivers in a familiar package. This module is optimized for low EMI characteristics.

Features

- 500V 3-phase inverter including high voltage gate drivers
- HVIC Temperature-Sensing Built-In for temperature Monitoring
- Works with 3.3V/5V MCU, Active-High interface
- HVIC for Under-voltage Protection
- Integrated bootstrap functionality
- Isolation Rating 1500V

Applications

- Energy efficient fans
- Pumps

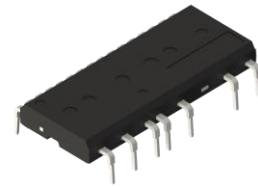

DIP-23E



Package Marking and Ordering Information

Part #	Marking	Package	Packing	Quantity	V _{TS}
CRM50TA06E1	CRM50TA06E1	DIP-23E	Tube	360	Yes

Internal Electrical Schematic

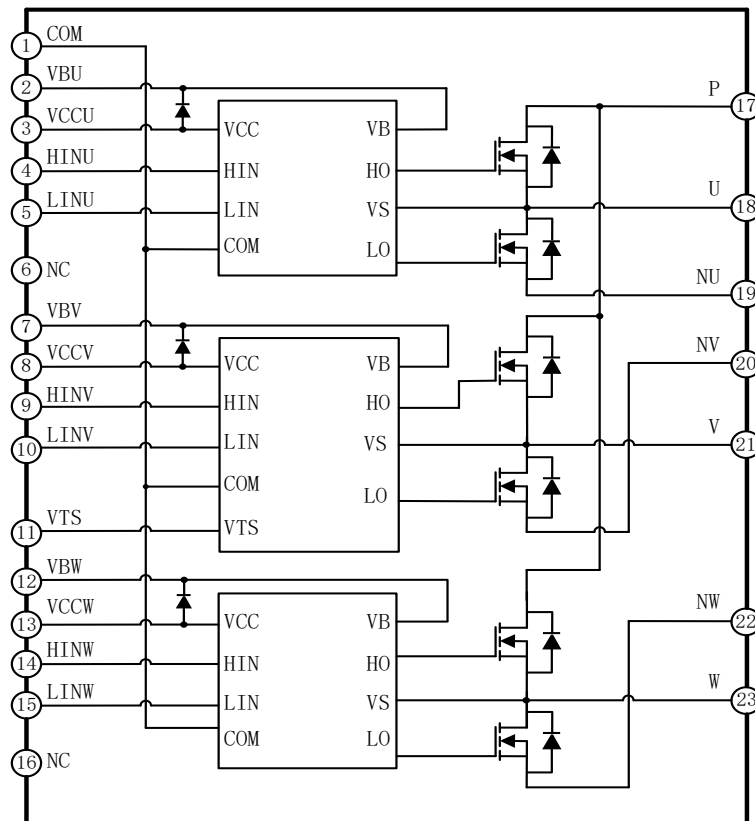

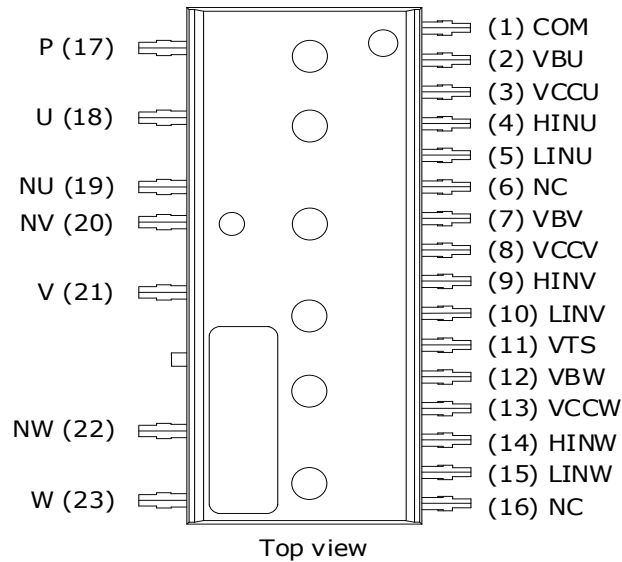
Module Pin-Out Description

Pin Number	Pin Name	Description
1	COM	Logic Ground
2	VBU	High Side Floating Supply Voltage U
3	VCCU	Low Side Supply Voltage U
4	HINU	Logic Input for High Side Gate Driver - Phase U
5	LINU	Logic Input for Low Side Gate Driver - Phase U
6	NC	Not Connected
7	VBV	High Side Floating Supply Voltage V
8	VCCV	Low Side Supply Voltage V
9	HINV	Logic Input for High Side Gate Driver - Phase V
10	LINV	Logic Input for Low Side Gate Driver - Phase V
11	VTS	Temperature-sensing Voltage Output
12	VBW	High Side Floating Supply Voltage W
13	VCCW	Low Side Supply Voltage W
14	HINW	Logic Input for High Side Gate Driver - Phase W
15	LINW	Logic Input for Low Side Gate Driver - Phase W
16	NC	Not Connected
17	P	DC Bus Voltage Positive
18	U	Output - Phase U, High Side Floating Supply Offset U
19	NU	Phase U Low Side Source
20	NV	Phase V Low Side Source
21	V	Output - Phase V, High Side Floating Supply Offset V
22	NW	Phase W Low Side Source
23	W	Output - Phase W, High Side Floating Supply Offset W

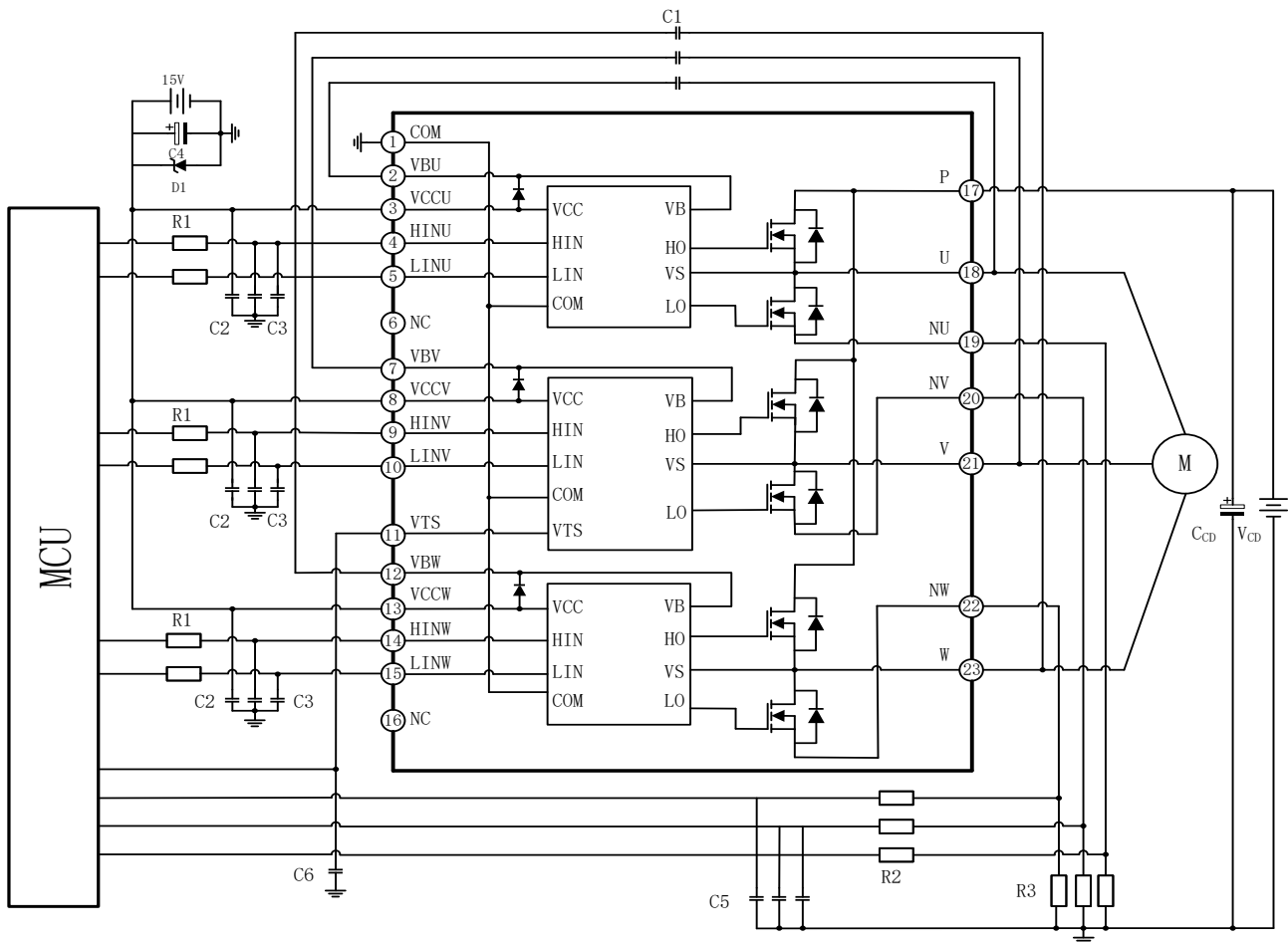
Application Circuit

Remark:

- 1、 Input drive is High-Active type.To prevent malfunction, the wiring of each input should be as short as possible.
When using RC coupling circuit, make sure the input signal level meet the turn-on and turn-off threshold voltage.
- 2、 Thanks for HVIC inside modules, direct coupling to MCU without any opto-coupler or transformer isolation is possible.
- 3、 The terminals of VTS is used to temperature detection, if you don't want to use it, please pull-down the terminal with a 100 KΩ resistor to GND. No connection is forbidden.
- 4、 All capacitors should be mounted as close to the terminals of the IPM as possible.
- 5、 The HIN and LIN have internal pull-down resistors. Additional pull-down resistors can be connected if necessary.
- 6、 Bootstrap negative electrodes should be connected to U, V, W terminals directly and separated from the main output wires.
- 7、 High frequency capacitor C1(greater than 2.2μF) is used as the bootstrap-up capacitor to absorb high frequency ripple.

Package Outline

DIP-23E

UNIT:mm

