

Description

CRM50TD04R1 is half-bridge Modules (IPM) designed for advanced appliance motor drive applications such as energy efficient fans and pumps.

These modules Integrated 2 fast recovery MOSFET and 1 high voltage gate driver in a familiar package. The modules are optimized for low EMI characteristics.

Features

- 500V half-bridge including high voltage gate drivers
- HVIC Temperature-Sensing Built-In for temperature Monitoring
- Works with 3.3V/5V MCU, Active-High interface
- HVIC for Under-voltage Protection
- Integrated bootstrap functionality
- Isolation Rating 1500V

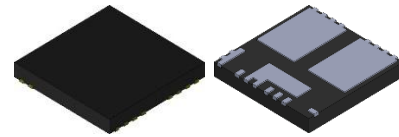

QFN7x7

Applications

- Energy efficient fans
- Pumps

Package Marking and Ordering Information

Part #	Marking	Package	Packing	Quantity	V _{TS}	Green
CRM50TD04R1	CRM50TD04R1	QFN7x7	Taping	3000	Yes	RoHS/HF

Internal Electrical Schematic

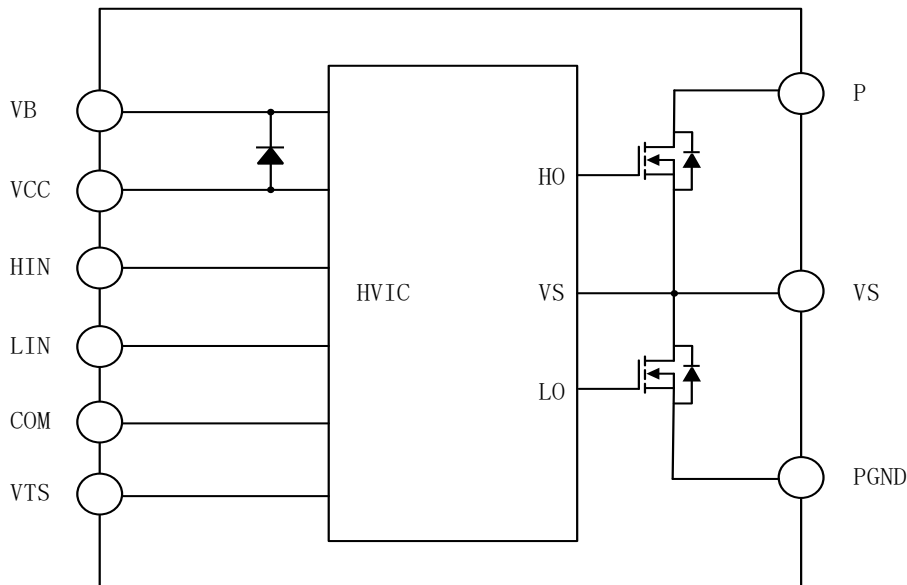

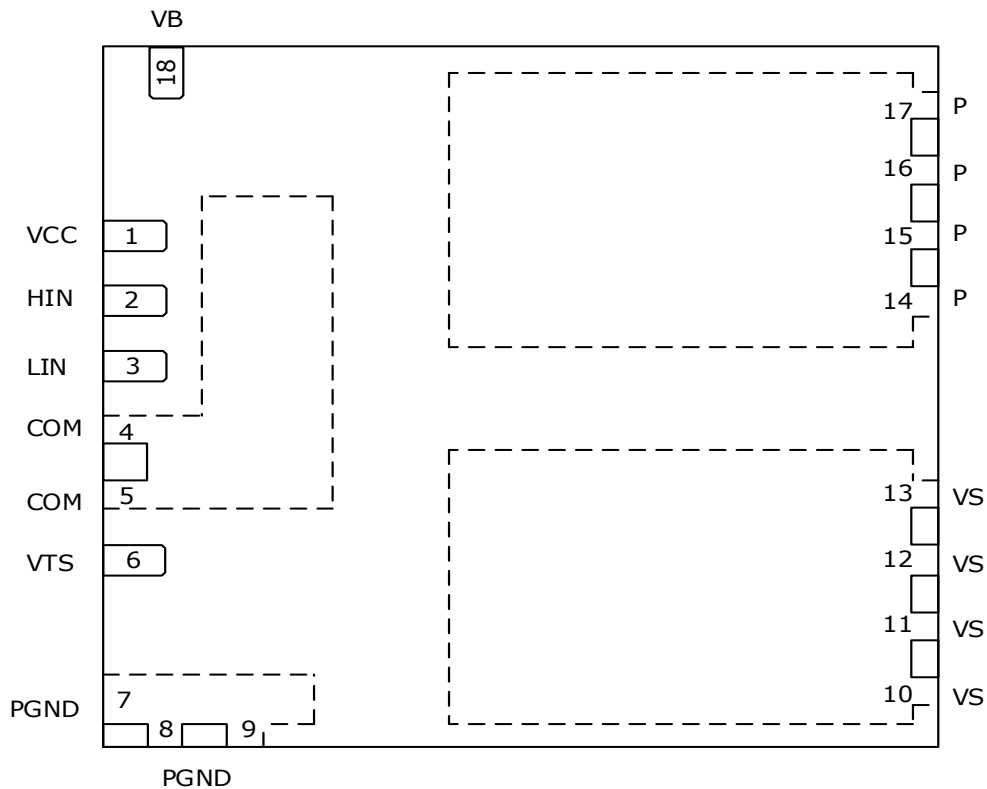
Module Pin-Out Description

Pin Number	Pin Name	Description
1	VCC	Power supply for Low side
2	HIN	Logic Input for High Side Gate Driver
3	LIN	Logic Input for Low Side Gate Driver
4,5	COM	Logic Ground
6	VTS	Temperature-sensing Voltage Output
7,8,9	PGND	Source for low side MOSFET
10,11,12,13	VS	High Side Floating Offset Voltage
14,15,16,17	P	DC Bus Voltage Positive
18	VB	High Side Floating Supply Voltage

Application Circuit

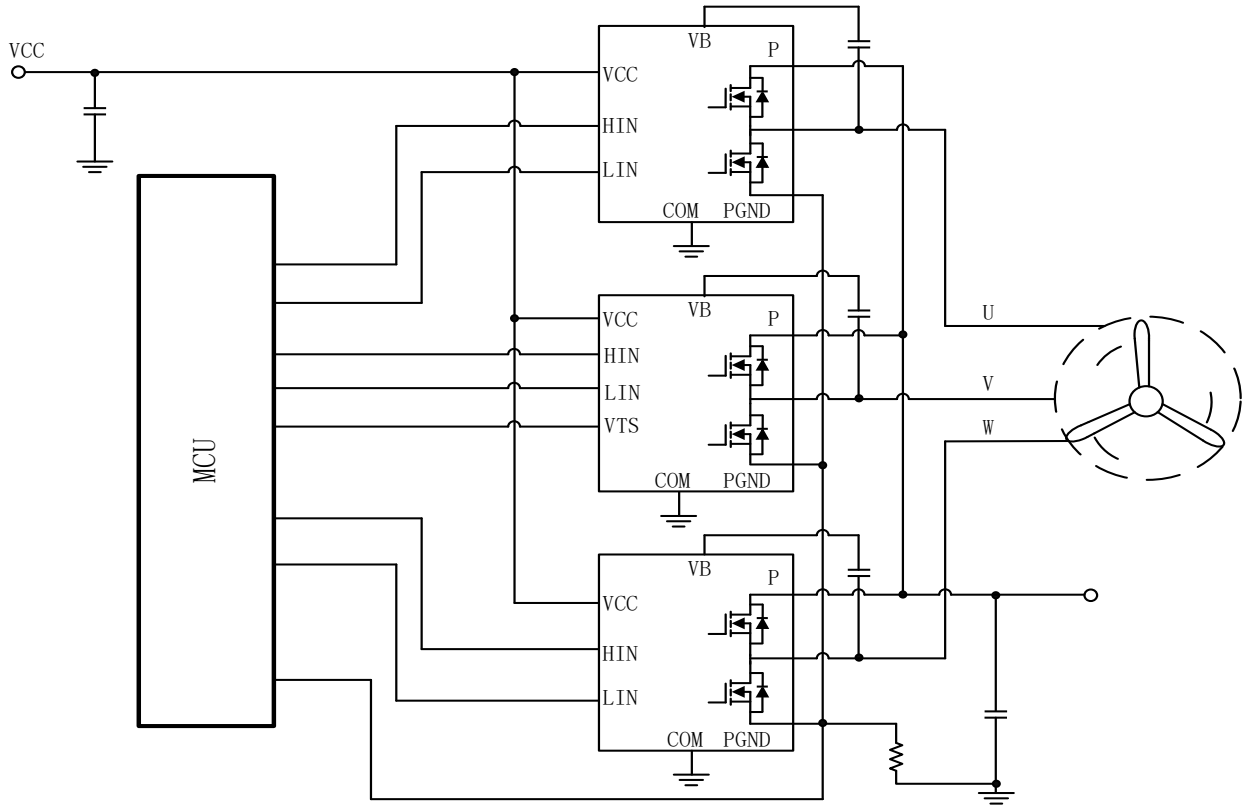

Package Outline

QFN7x7

UNIT:mm

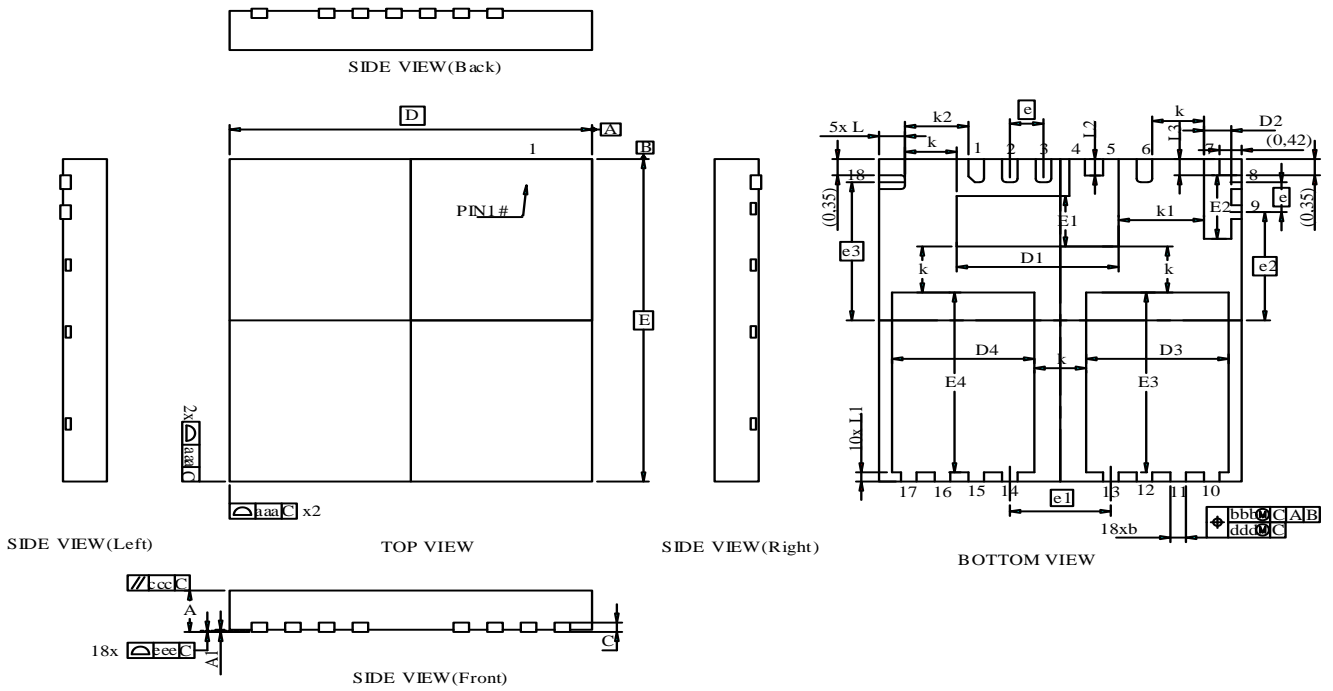

DIM SYMBOL	MIN.	NOM.	MAX.	DIM SYMBOL	MIN.	NOM.	MAX.
A	0.80	0.90	1.00	e1	1.95 BSC		
	0.75	0.85	0.95	e2	2.35 BSC		
C	-	0.203 REF	-	e3	3.00 BSC		
A1	-	-	0.05	L	0.45	0.50	0.55
b	0.25	0.30	0.35	L1	0.15	0.20	0.25
D	7.00 BSC			L2	0.305	0.355	0.405
E	7.00 BSC			L3	0.30	0.35	0.40
D1	3.025	3.125	3.225	k	-	1.00	-
E1	0.996	1.096	1.196	k1	-	1.65	-
D2	0.425	0.525	0.625	k2	-	1.225	-
E2	1.28	1.38	1.48	aaa	0.15		
D3	2.65	2.75	2.85	bbb	0.10		
E3	3.804	3.904	4.004	ccc	0.10		
D4	2.65	2.75	2.85	ddd	0.05		
E4	3.804	3.904	4.004	eee	0.08		
e	0.65 BSC				-		