

Description

CRM60GH10E4 are 3-phase Integrated Power Modules (IPM) designed for advanced appliance motor drive applications such as refrigerator compressor and pumps.

CRM60GH10E4 Integrated 6 low-loss IGBTs and FRDs, 3-phase full bridge drivers in a familiar package. The modules are optimized for low EMI characteristics.

Features

- 600V/10A three-phase inverter
- Works with 3.3V/5V MCU
- Integrated under-voltage protection
- Integrated high accurate short-circuit current protection
- Integrated >40 μ s fault duration time
- Integrated built-in temperature-sensing
- Integrated over temperature protection
- Integrated bootstrap diodes with current limiting resistor
- Isolation rating: 1500 Vrms/min

Applications

- Refrigerator compressor
- Air condition compressor
- Low-power inverters
- Pumps

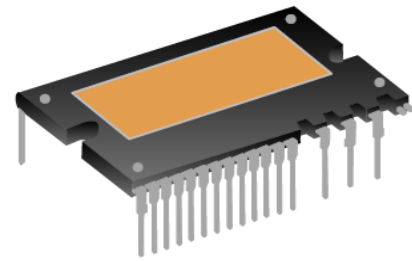

DIP-24B

Package Marking and Ordering Information

Part #	Marking	Package	Packing	Quantity	Green
CRM60GH10E4	CRM60GH10E4	DIP-24B	Tube	360	RoHS/HF

Internal Electrical Schematic

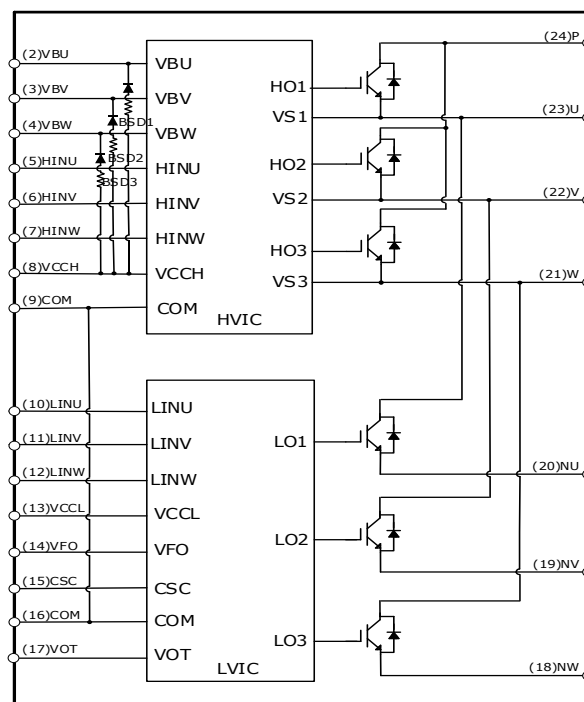

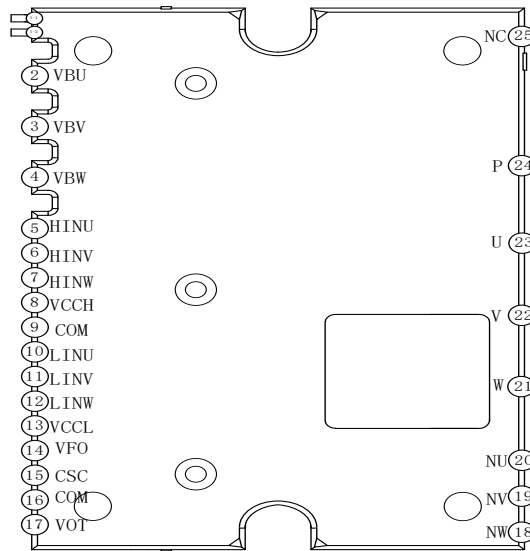
Module Pin-Out Description

Bottom view

Pin Number	Pin Name	Description
2	VBU	High Side Floating Supply Voltage U
3	VBV	High Side Floating Supply Voltage V
4	VBW	High Side Floating Supply Voltage W
5	HINU	Logic Input for High Side Gate Driver - Phase U
6	HINV	Logic Input for High Side Gate Driver - Phase V
7	HINW	Logic Input for High Side Gate Driver - Phase W
8	VCCH	High side IC supply voltage
9	COM	Logic Ground
10	LINU	Logic Input for Low Side Gate Driver - Phase U
11	LINV	Logic Input for Low Side Gate Driver - Phase V
12	LINW	Logic Input for Low Side Gate Driver - Phase W
13	VCCL	Low side IC supply voltage
14	VFO	Fault output / Temperature monitor
15	CSC	External capacitance, Short-current detection input
16	COM	Logic Ground
17	VOT	Output for Temperature Sensing
18	NW	Phase W Low Side Emitter
19	NV	Phase V Low Side Emitter
20	NU	Phase U Low Side Emitter
21	W	Output - Phase W, High Side Floating Supply Offset W
22	V	Output - Phase V, High Side Floating Supply Offset V
23	U	Output - Phase U, High Side Floating Supply Offset U
24	P	DC Bus Voltage Positive
25	NC	Not Connected

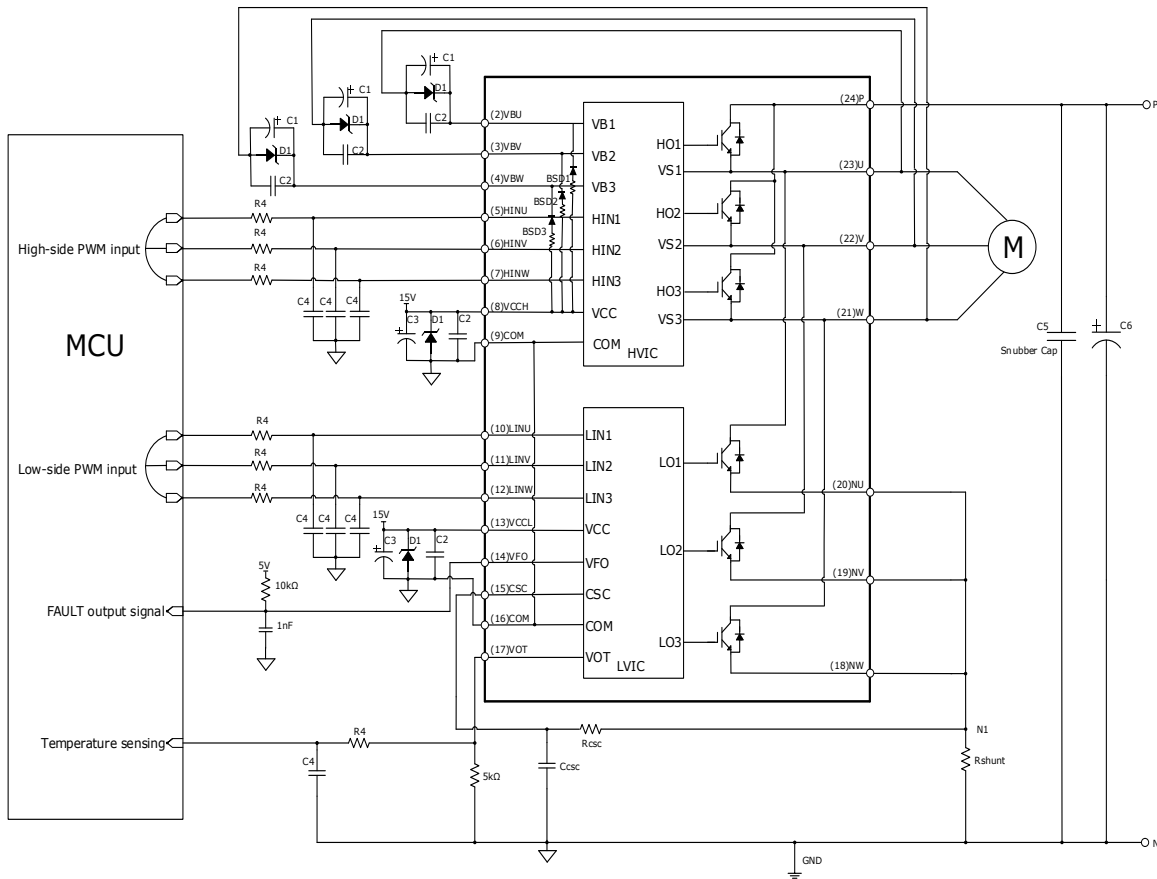
Application Circuit



Remark:

- 1、 To prevent malfunction, the wiring of each input should be as short as possible.
- 2、 Input drive is High-Active type. There is a $5k\Omega$ (typ.) pull-down resistor integrated in the IC input circuit. And adding RC filter circuit to the input will prevent the surge noise caused by incorrect input.
- 3、 To prevent surge damage, it is recommended to add a high-frequency non-inductive flat capacitor (0.1 μ F to 0.22 μ F) between P and N. The cable connection of the capacitor should be as short as possible.
- 4、 The line between the current detection resistor and the IPM should be as short as possible, otherwise the large surge voltage generated by the connecting inductor may cause damage.
- 5、 All capacitors should be mounted as close to the terminals of the IPM as possible.
- 6、 FO output is open drain type. It should be pulled up to the positive side of 5V power supply by a resistor of about 10k Ω .
- 7、 The time constant R_{sc} and C_{sc} of the protection circuit should be selected in the range of 1.5-2.0 μ s.

Package Outline

DIP-24B

UNIT:mm

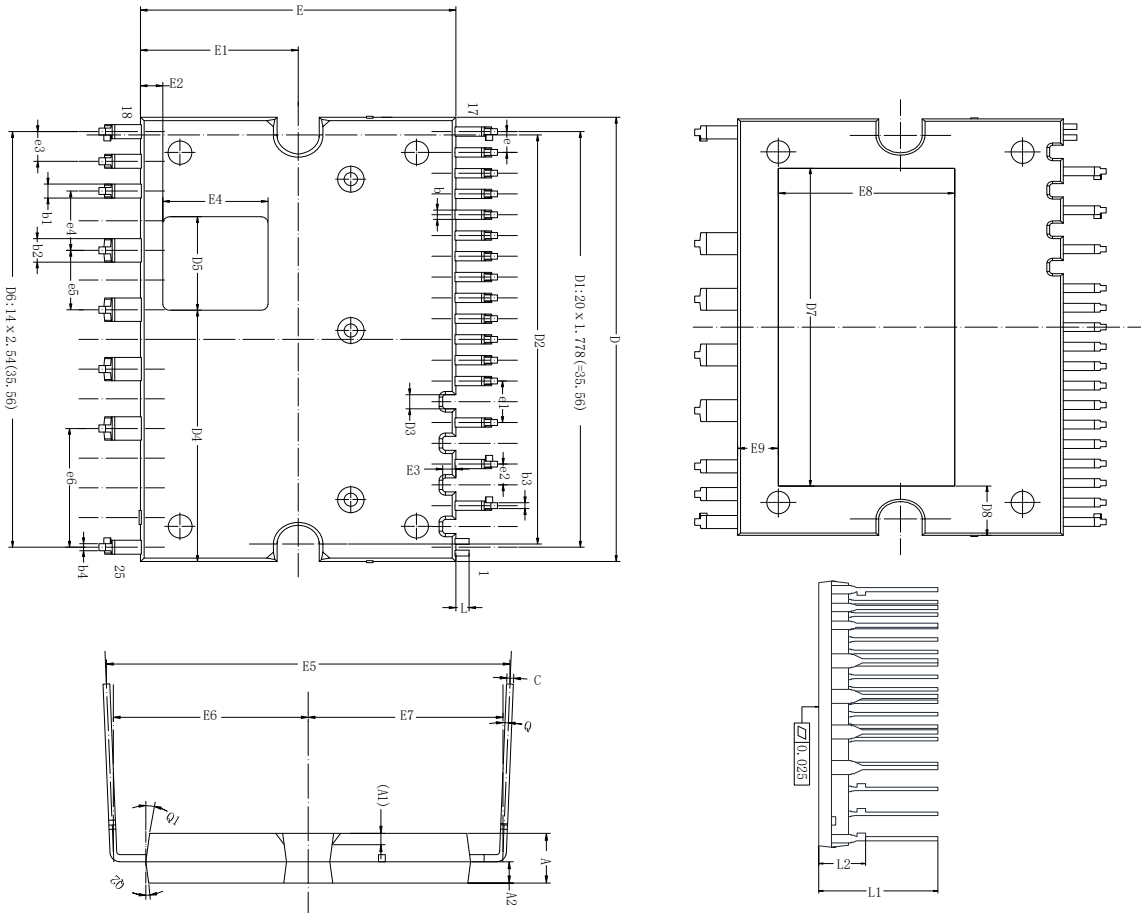

SY	COMMON			SY	COMMON		
	Dimensions millimeter				Dimensions millimeter		
	Min	Nom	Max		Min	Nom	Max
A	3.40	3.50	3.60	(E3)	0.90	1.00	1.10
(A1)	0.40	0.50	0.60	E4	7.80	8.00	8.20
A2	1.48	1.50	1.52	E5	28.90	29.40	29.90
b	0.75	0.80	0.85	E6	13.90	14.40	14.90
b1	1.15	1.20	1.25	E7	13.90	14.40	14.90
b2	1.95	2.00	2.05	E8	12.80	13.00	13.20
b3	0.45	0.50	0.55	E9	2.60	3.00	3.40
b4	0.55	0.60	0.65	e	1.728	1.778	1.828
C	0.45	0.50	0.55	e1	3.506	3.556	3.606
D	37.80	38.00	38.20	e2	1.728	1.778	1.828
(D1)	35.51	35.56	35.61	e3	2.490	2.540	2.590
(D2)	34.90	35.00	35.10	e4	5.030	5.080	5.130
D3	1.10	1.20	1.30	e5	5.030	5.080	5.130
D4	21.30	21.50	21.70	e6	10.11	10.16	10.21
D5	7.80	8.00	8.20	L	0.90	1.00	1.10
D6	35.51	35.56	35.61	L1	13.70	14.00	14.30
D7	28.80	29.00	29.20	L2	5.2	5.5	5.8
D8	4.10	4.50	4.90	(Q)	0°	2.5°	5°
E	23.80	24.00	24.20	Q1	7°	8°	9°
E1	11.90	12.00	12.10	Q2	7°	8°	9°
E2	1.50	1.70	1.90				