

Description

Features

- -30V, -80A
- $R_{DS(ON)}$ Typ = 4.4mΩ @ $V_{GS} = -10V$
- $R_{DS(ON)}$ Typ = 7.1mΩ @ $V_{GS} = -4.5V$
- Advanced Trench Technology
- Excellent $R_{DS(ON)}$ and Low Gate Charge
- 100% UIS TESTED!
- 100% ΔV_{ds} TESTED!

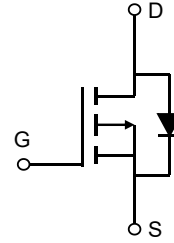

Schematic Diagram

Application

- Load Switch
- PWM Application
- Power Management

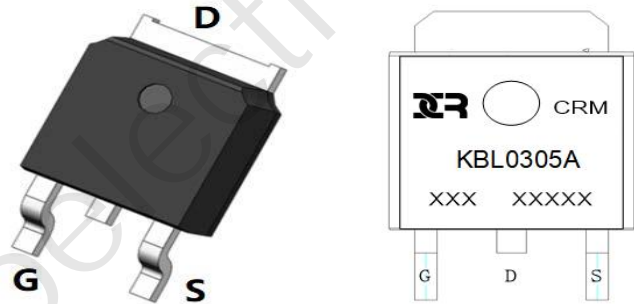

Marking and Pin Assignment

Package Marking and Ordering Information

Device	Marking	Package	Outline	Reel Size	Reel (pcs)	Per Carton (pcs)
CRMKBL0305A	CRMKBL0305A	TO-252-3L	TAPING	13"	2500	25000

Absolute Maximum Ratings (@ $T_J = 25^\circ\text{C}$ unless otherwise specified)

Symbol	Parameter	Value	Units
V_{DS}	Drain-to-Source Voltage	-30	V
V_{GS}	Gate-to-Source Voltage	±20	V
I_D	Continuous Drain Current	$T_C = 25^\circ\text{C}$	-80
		$T_C = 100^\circ\text{C}$	-48
I_{DM}	Pulsed Drain Current ⁽¹⁾	-320	A
E_{AS}	Single Pulsed Avalanche Energy ⁽²⁾	132	mJ
P_D	Power Dissipation	$T_C = 25^\circ\text{C}$	62.5
$R_{\theta JC}$	Thermal Resistance, Junction to Case	2	°C/W
T_J, T_{STG}	Junction & Storage Temperature Range	-55 to 150	°C

Electrical Characteristics (T_J = 25°C unless otherwise specified)

Symbol	Parameter	Conditions	Min.	Typ.	Max.	Unit
Off Characteristics						
V _{(BR)DSS}	Drain-Source Breakdown Voltage	I _D = -250μA, V _{GS} = 0V	-30	-	-	V
I _{DSS}	Zero Gate Voltage Drain Current	V _{DS} = -30V, V _{GS} = 0V	-	-	-1.0	μA
I _{GSS}	Gate-Body Leakage Current	V _{DS} = 0V, V _{GS} = ±20V	-	-	±100	nA
On Characteristics						
V _{GS(th)}	Gate Threshold Voltage	V _{DS} = V _{GS} , I _D = -250μA	-1.1	-1.6	-2.2	V
R _{DS(ON)}	Static Drain-Source ON-Resistance ⁽³⁾	V _{GS} = -10V, I _D = -20A	-	4.4	5.7	mΩ
		V _{GS} = -4.5V, I _D = -10A	-	7.1	9.2	mΩ
Dynamic Characteristics						
C _{iss}	Input Capacitance	V _{GS} = 0V, V _{DS} = -15V, f = 1MHz	-	2754	-	pF
C _{oss}	Output Capacitance		-	505	-	pF
C _{rss}	Reverse Transfer Capacitance		-	415	-	pF
Q _g	Total Gate Charge	V _{GS} = 0 to -10V V _{DS} = -15V, I _D = -5A	-	69	-	nC
Q _{gs}	Gate Source Charge		-	12	-	nC
Q _{gd}	Gate Drain("Miller") Charge		-	13	-	nC
Switching Characteristics						
t _{d(on)}	Turn-On DelayTime	V _{GS} = -10V, V _{DD} = -15V I _D = -10A, R _{GEN} = 3Ω	-	12	-	ns
t _r	Turn-On Rise Time		-	72	-	ns
t _{d(off)}	Turn-Off DelayTime		-	78	-	ns
t _f	Turn-Off Fall Time		-	60	-	ns
Drain-Source Diode Characteristics and Max Ratings						
I _S	Maximum Continuous Drain to Source Diode Forward Current		-	-	-80	A
I _{SM}	Maximum Pulsed Drain to Source Diode Forward Current		-	-	-320	A
V _{SD}	Drain to Source Diode Forward Voltage	V _{GS} = 0V, I _S = -20A	-	-	-1.2	V
trr	Body Diode Reverse Recovery Time	I _F = -20A, di/dt = 100A/us	-	23	-	ns
Qrr	Body Diode Reverse Recovery Charge		-	50	-	nC

- Notes:
1. Repetitive Rating: Pulse Width Limited by Maximum Junction Temperature.
 2. E_{AS} condition: Starting T_J=25°C, V_{DD}=-15V, V_G=10V, R_G=25ohm, L=0.5mH, I_{AS}=-23A
 3. Pulse Test: Pulse Width ≤ 300μs, Duty Cycle ≤ 0.5%.

Test Circuit

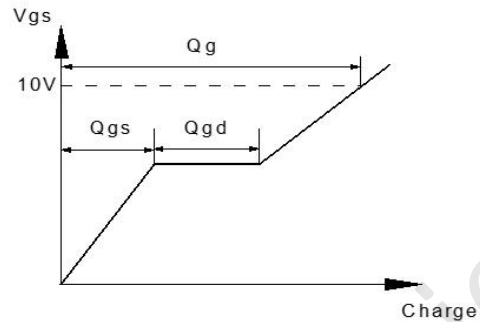
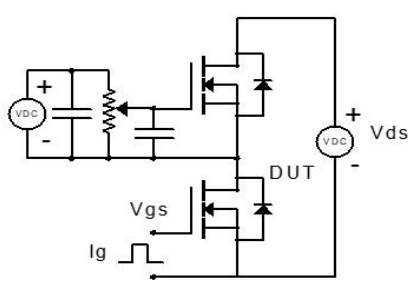

Figure 1: Gate Charge Test Circuit & Waveform

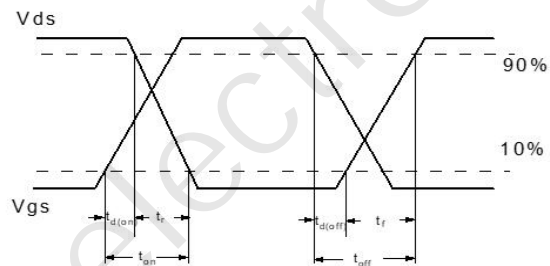
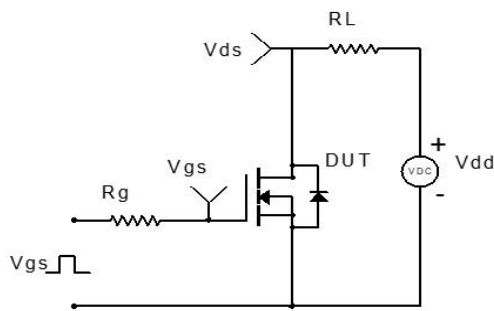

Figure 2: Resistive Switching Test Circuit & Waveform

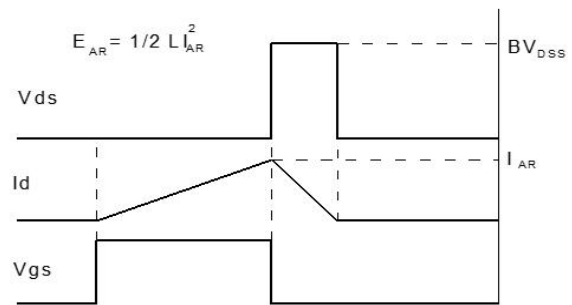
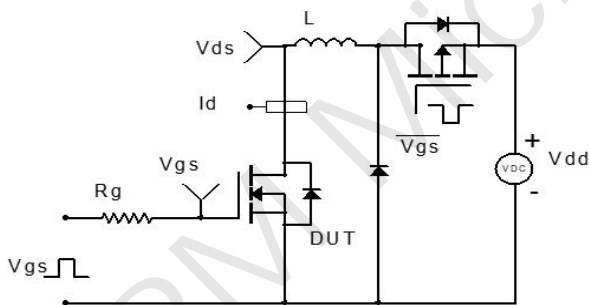

Figure 3: Unclamped Inductive Switching Test Circuit & Waveform

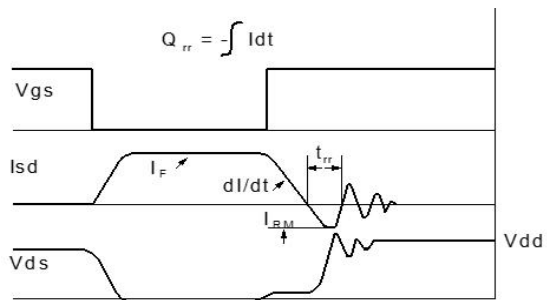
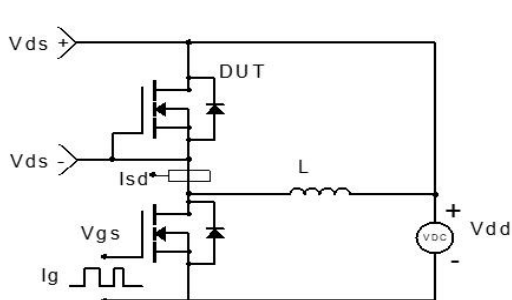
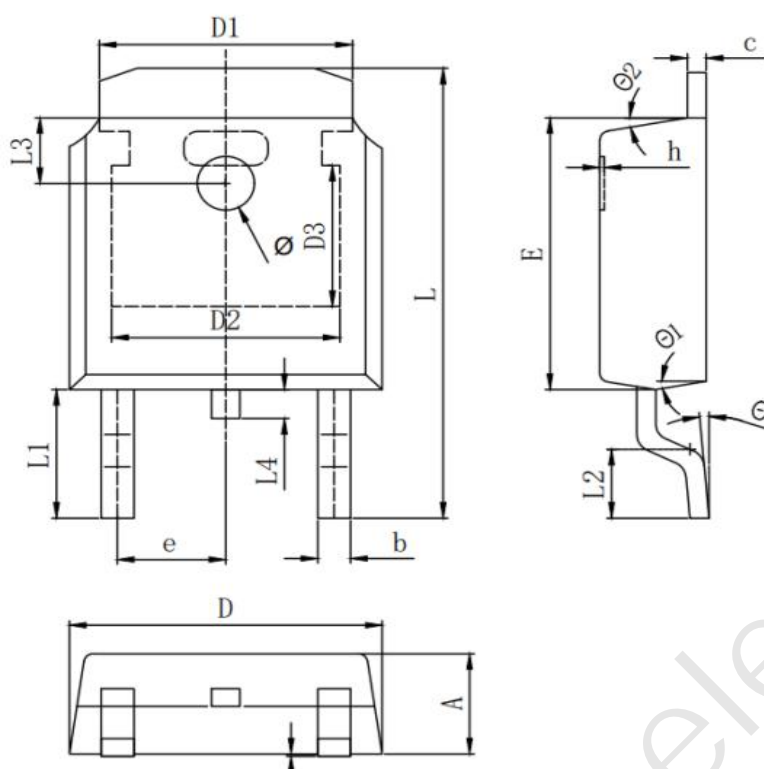

Figure 4: Diode Recovery Test Circuit & Waveform

Package Mechanical Data(TO-252-3L)



SYMBOL	MILLIMETER		
	MIN	Typ.	MAX
A	2.200	2.300	2.400
A1	0.000		0.127
b	0.640	0.690	0.740
c (电镀后)	0.460	0.520	0.580
D	6.500	6.600	6.700
D1	5.334 REF		
D2	4.826 REF		
D3	3.166 REF		
E	6.000	6.100	6.200
e	2.286 TYP		
h	0.000	0.100	0.200
L	9.900	10.100	10.300
L1	2.888 REF		
L2	1.400	1.550	1.700
L3	1.600 REF		
L4	0.600	0.800	1.000
φ	1.100	1.200	1.300
θ	0°		8°
θ1	9° TYP		
θ2	9° TYP		

Important Notice

The information presented in datasheets is for reference only. CRM reserves the right to make changes at any time to any products or information herein, without notice.

Customers are responsible for the design and applications, including compliance with all laws, regulations and safety requirements or standards.

“Typical” parameters which provided in datasheets can vary in different applications and actual performance may vary over time. Customers are responsible for doing all necessary testing to minimize the risks associated with their applications and products.

 is a registered trademark of Wuxi CRM Microelectronics Co., Ltd.

Copyright ©2023 CRM Microelectronics Co., Ltd. All rights reserved.

Contact information

For more information, please visit: <http://www.crm-semi.tech>

For sales information, please send an email to: sales@crm-semi.com