

## Description

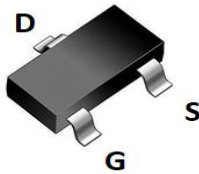
### N-channel Enhancement Mode Power MOSFET

#### Features

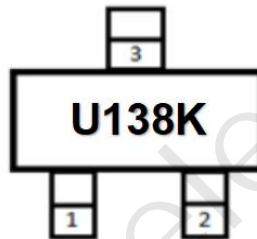
- 60V, 0.3A  
 $R_{DS(ON)}$  Typ= 1.9Ω @  $V_{GS} = 4.5V$   
 $R_{DS(ON)}$  Typ= 2.3Ω @  $V_{GS} = 2.5V$
- Advanced Trench Technology
- Excellent  $R_{DS(ON)}$  and Low Gate Charge
- Lead Free
- ESD Protected: 1.5KV

#### Applications

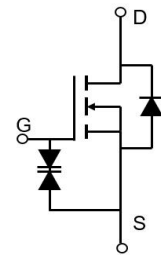
- Battery Operated System
- Direct logic-level Interfac:  
TTL/CMOS
- Solid-State Relays



SOT-23



Marking and Pin Assignment



Schematic Diagram

### Package Marking and Ordering Information

Device Marking	Device	Outline	Package	Reel Size	Reel(pcs)	Per Carton (pcs)
U138K	CRMLTU138K	TAPING	SOT-23	7"	3000	120000

### Absolute Maximum Ratings (@ $T_J = 25^\circ C$ unless otherwise specified)

Symbol	Parameter	Value	Units
$V_{DS}$	Drain-to-Source Voltage	60	V
$V_{GS}$	Gate-to-Source Voltage	±20	V
$I_D$	Continuous Drain Current	$T_A = 25^\circ C$	0.3
		$T_A = 100^\circ C$	0.2
$I_{DM}$	Pulsed Drain Current <sup>(1)</sup>	1.2	A
$P_D$	Power Dissipation	$T_A = 25^\circ C$	0.35
$R_{\theta JA}$	Thermal Resistance, Junction to Ambient <sup>(2)</sup>	357	°C/W
$T_J, T_{STG}$	Junction & Storage Temperature Range	-55 to 150	°C

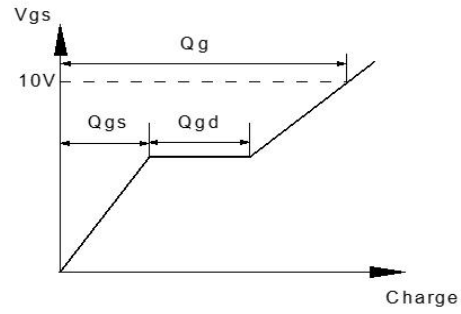
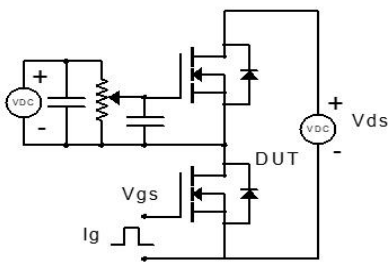


## Electrical Characteristics (T<sub>J</sub> = 25°C unless otherwise specified)

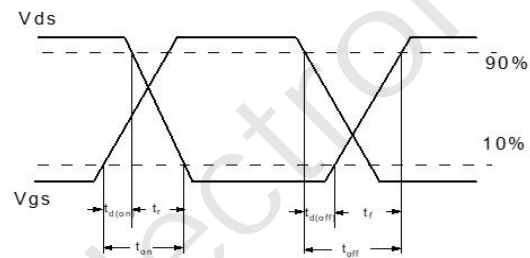
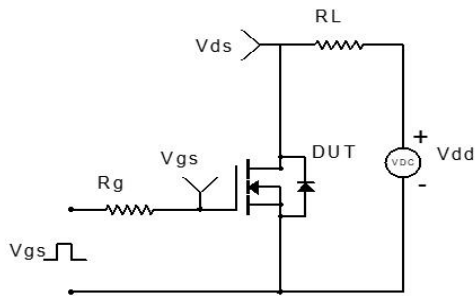
Symbol	Parameter	Conditions	Min.	Typ.	Max.	Unit
<b>Off Characteristics</b>						
V <sub>(BR)DSS</sub>	Drain-Source Breakdown Voltage	I <sub>D</sub> = 250μA, V <sub>GS</sub> = 0V	60	-	-	V
I <sub>DSS</sub>	Zero Gate Voltage Drain Current	V <sub>DS</sub> = 60V, V <sub>GS</sub> = 0V	-	-	1.0	μA
I <sub>GSS</sub>	Gate-Body Leakage Current	V <sub>DS</sub> = 0V, V <sub>GS</sub> = ±20V	-	-	±10	μA
<b>On Characteristics</b>						
V <sub>GS(th)</sub>	Gate Threshold Voltage	V <sub>DS</sub> = V <sub>GS</sub> , I <sub>D</sub> = 250μA	0.5	0.85	1.2	V
R <sub>DS(ON)</sub>	Static Drain-Source ON-Resistance <sup>(3)</sup>	V <sub>GS</sub> = 4.5V, I <sub>D</sub> = 0.3A	-	1.9	2.5	Ω
		V <sub>GS</sub> = 2.5V, I <sub>D</sub> = 0.2A	-	2.3	4.5	Ω
<b>Dynamic Characteristics</b>						
C <sub>iss</sub>	Input Capacitance	V <sub>GS</sub> = 0V, V <sub>DS</sub> = 25V, f = 1MHz	-	22	-	pF
C <sub>oss</sub>	Output Capacitance		-	3	-	pF
C <sub>rss</sub>	Reverse Transfer Capacitance		-	2	-	pF
Q <sub>g</sub>	Total Gate Charge	V <sub>GS</sub> = 0 to 4.5V V <sub>DS</sub> = 10V, I <sub>D</sub> = 0.3A	-	1.8	-	nC
Q <sub>gs</sub>	Gate Source Charge		-	0.4	-	nC
Q <sub>gd</sub>	Gate Drain("Miller") Charge		-	0.7	-	nC
<b>Switching Characteristics</b>						
t <sub>d(on)</sub>	Turn-On DelayTime	V <sub>GS</sub> = 10V, V <sub>DD</sub> = 10V I <sub>D</sub> = 0.2A, R <sub>GEN</sub> = 10Ω	-	2	-	ns
t <sub>r</sub>	Turn-On Rise Time		-	16	-	ns
t <sub>d(off)</sub>	Turn-Off DelayTime		-	7	-	ns
t <sub>f</sub>	Turn-Off Fall Time		-	19	-	ns
<b>Drain-Source Diode Characteristics and Max Ratings</b>						
I <sub>S</sub>	Maximum Continuous Drain to Source Diode Forward Current		-	-	0.3	A
I <sub>SM</sub>	Maximum Pulsed Drain to Source Diode Forward Current		-	-	1.2	A
V <sub>SD</sub>	Drain to Source Diode Forward Voltage	V <sub>GS</sub> = 0V, I <sub>S</sub> = 0.3A	-	-	1.2	V

- Notes:
1. Repetitive Rating: Pulse Width Limited by Maximum Junction Temperature.
  2. R<sub>θJA</sub> is measured with the device mounted on a 1inch<sup>2</sup> pad of 2oz copper FR4 PCB
  3. Pulse Test: Pulse Width ≤ 300μs, Duty Cycle ≤ 0.5%.

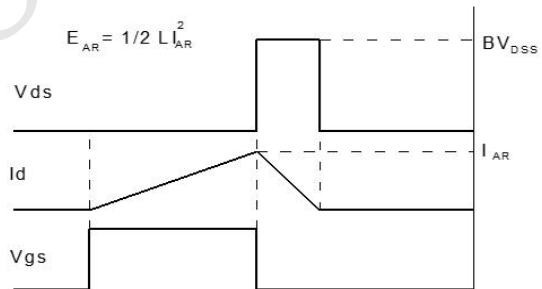
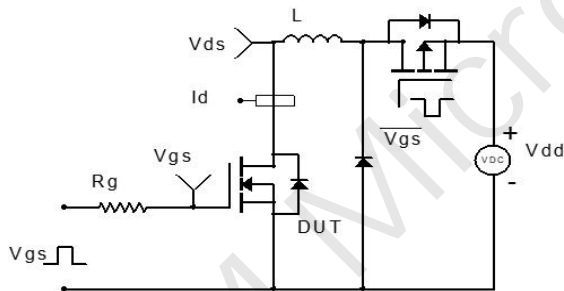
## Test Circuit



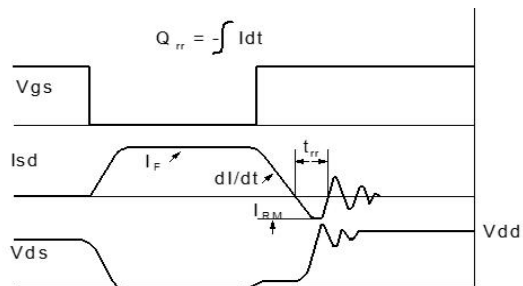
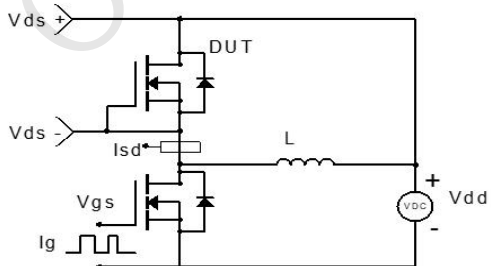
**Figure 1: Gate Charge Test Circuit & Waveform**



**Figure 2: Resistive Switching Test Circuit & Waveform**

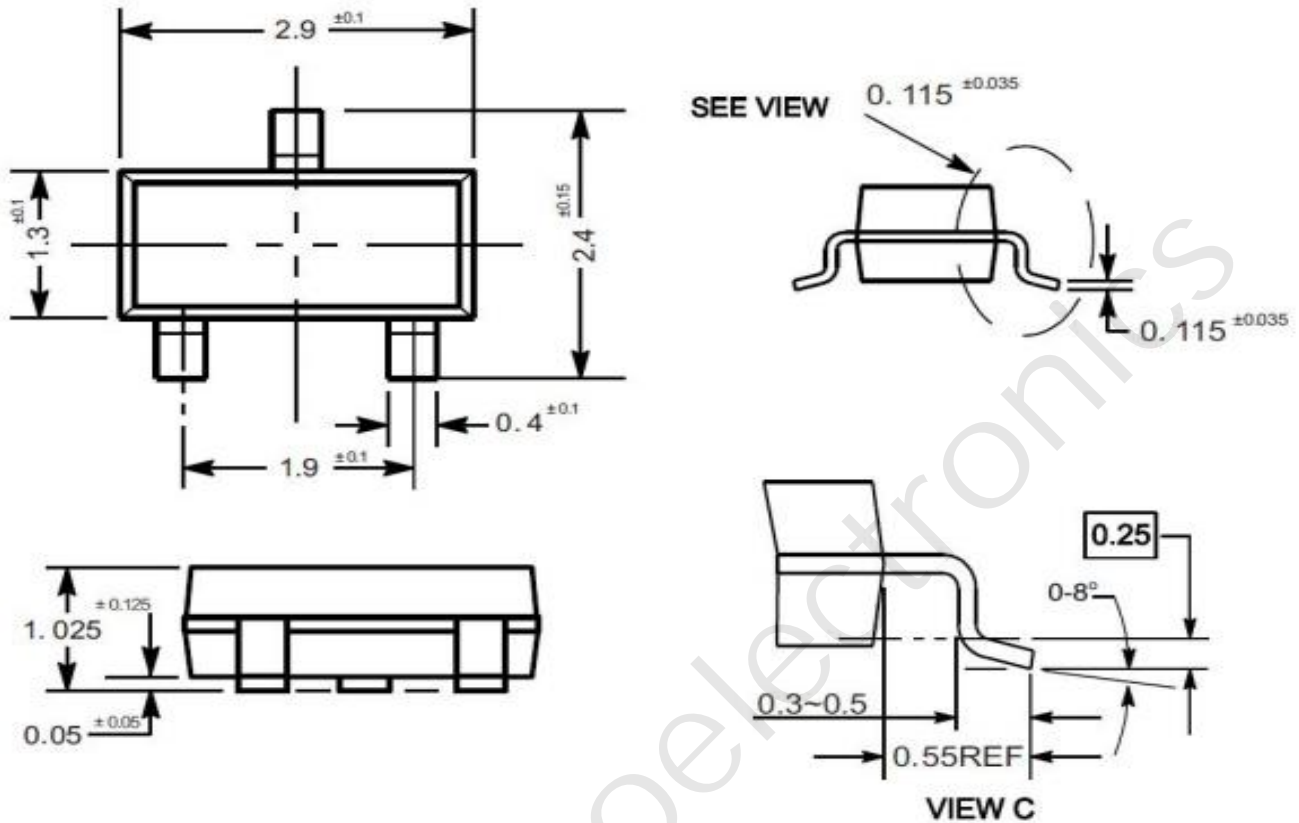


**Figure 3: Unclamped Inductive Switching Test Circuit & Waveform**



**Figure 4: Diode Recovery Test Circuit & Waveform**

## Package Mechanical Data(SOT-23)



Information furnished in this document is believed to be accurate and reliable. However, CRM Microelectronics Co. , Ltd assumes no responsibility for the consequences of use without consideration for such information nor use beyond it.

Information mentioned in this document is subject to change without notice, apart from that when an agreement is signed, CRM complies with the agreement.

Products and information provided in this document have no infringement of patents. CRM assumes no responsibility for any infringement of other rights of third parties which may result from the use of such products and information.

is a registered trademark of CRM Microelectronics Co. , Ltd.

Copyright ©2023 CRM Microelectronics Co. , Ltd. Printed All rights reserved.