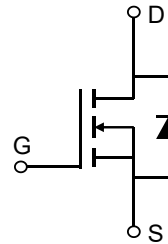


### Description

#### Features

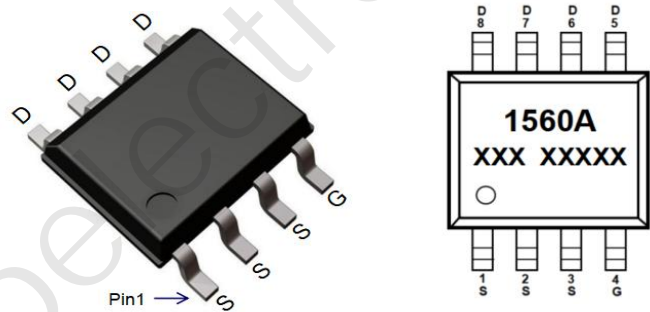
- 150V, 4.5A  
 $R_{DS(ON)}$  Typ = 61.5mΩ @  $V_{GS} = 10V$
- Advanced Split Gate Trench Technology
- Excellent  $R_{DS(ON)}$  and Low Gate Charge
- Lead Free
- 100% UIS TESTED!



Schematic Diagram

#### Application

- Load Switch
- PWM Application
- Power Management



Marking and Pin Assignment

#### Package Marking and Ordering Information

Device	Marking	Package	Outline	Reel Size	Reel (pcs)	Per Carton (pcs)
CRMPGH1560A	1560A	SOP-8	TAPING	13"	4000	40000

#### Absolute Maximum Ratings (@ $T_J = 25^\circ C$ unless otherwise specified)

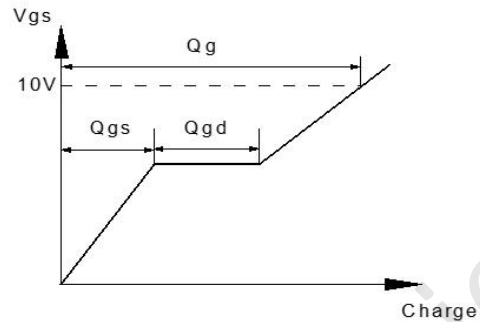
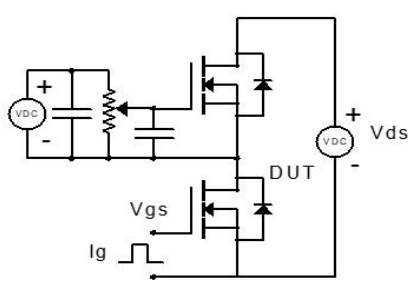
Symbol	Parameter	Value	Units
$V_{DS}$	Drain-to-Source Voltage	150	V
$V_{GS}$	Gate-to-Source Voltage	±20	V
$I_D$	Continuous Drain Current	$T_A = 25^\circ C$	4.5
		$T_A = 100^\circ C$	2.7
$I_{DM}$	Pulsed Drain Current <sup>(1)</sup>	18	A
$E_{AS}$	Single Pulsed Avalanche Energy <sup>(2)</sup>	20	mJ
$P_D$	Power Dissipation	$T_A = 25^\circ C$	3.1
$R_{\theta JA}$	Thermal Resistance, Junction to Ambient <sup>(3)</sup>	40	°C/W
$T_J, T_{STG}$	Junction & Storage Temperature Range	-55 to 150	°C

### Electrical Characteristics (T<sub>J</sub> = 25°C unless otherwise specified)

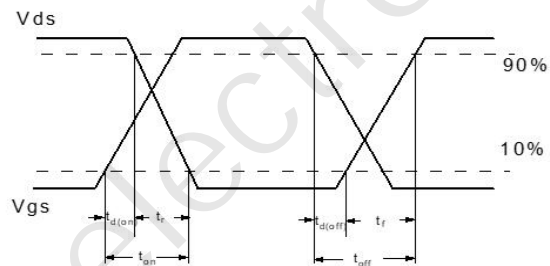
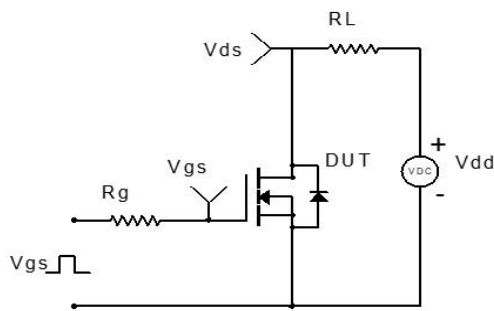
Symbol	Parameter	Conditions	Min.	Typ.	Max.	Unit
<b>Off Characteristics</b>						
V <sub>(BR)DSS</sub>	Drain-Source Breakdown Voltage	I <sub>D</sub> = 250μA, V <sub>GS</sub> = 0V	150	-	-	V
I <sub>DSS</sub>	Zero Gate Voltage Drain Current	V <sub>DS</sub> = 150V, V <sub>GS</sub> = 0V	-	-	1.0	μA
I <sub>GSS</sub>	Gate-Body Leakage Current	V <sub>DS</sub> = 0V, V <sub>GS</sub> = ±20V	-	-	±100	nA
<b>On Characteristics</b>						
V <sub>GS(th)</sub>	Gate Threshold Voltage	V <sub>DS</sub> = V <sub>GS</sub> , I <sub>D</sub> = 250μA	2.4	3	3.6	V
R <sub>DS(ON)</sub>	Static Drain-Source ON-Resistance <sup>(4)</sup>	V <sub>GS</sub> = 10V, I <sub>D</sub> = 3A	-	61.5	80	mΩ
<b>Dynamic Characteristics</b>						
C <sub>iss</sub>	Input Capacitance	V <sub>GS</sub> = 0V, V <sub>DS</sub> = 75V, f = 1MHz	-	368	-	pF
C <sub>oss</sub>	Output Capacitance		-	50	-	pF
C <sub>rss</sub>	Reverse Transfer Capacitance		-	4	-	pF
Q <sub>g</sub>	Total Gate Charge	V <sub>GS</sub> = 0 to 10V V <sub>DS</sub> = 75V, I <sub>D</sub> = 2A	-	5.5	-	nC
Q <sub>gs</sub>	Gate Source Charge		-	1.2	-	nC
Q <sub>gd</sub>	Gate Drain("Miller") Charge		-	2	-	nC
<b>Switching Characteristics</b>						
t <sub>d(on)</sub>	Turn-On DelayTime	V <sub>GS</sub> = 10V, V <sub>DD</sub> = 75V I <sub>D</sub> = 2A, R <sub>GEN</sub> = 6Ω	-	4.6	-	ns
t <sub>r</sub>	Turn-On Rise Time		-	3.3	-	ns
t <sub>d(off)</sub>	Turn-Off DelayTime		-	7.5	-	ns
t <sub>f</sub>	Turn-Off Fall Time		-	3.6	-	ns
<b>Drain-Source Diode Characteristics and Max Ratings</b>						
I <sub>S</sub>	Maximum Continuous Drain to Source Diode Forward Current		-	-	4.5	A
I <sub>SM</sub>	Maximum Pulsed Drain to Source Diode Forward Current		-	-	18	A
V <sub>SD</sub>	Drain to Source Diode Forward Voltage	V <sub>GS</sub> = 0V, I <sub>S</sub> = 3A	-	-	1.2	V
t <sub>rr</sub>	Body Diode Reverse Recovery Time	I <sub>F</sub> = 4A, di/dt = 100A/us	-	70	-	ns
Q <sub>rr</sub>	Body Diode Reverse Recovery Charge		-	80	-	nC

- Notes:
1. Repetitive Rating: Pulse Width Limited by Maximum Junction Temperature.
  2. E<sub>AS</sub> condition: Starting T<sub>J</sub>=25°C, V<sub>DD</sub>=50V, V<sub>G</sub>=10V, R<sub>G</sub>=25ohm, L=0.5mH, I<sub>AS</sub>=9A
  3. R<sub>θJA</sub> is measured with the device mounted on a 1inch<sup>2</sup> pad of 2oz copper FR4 PCB
  4. Pulse Test: Pulse Width ≤ 300μs, Duty Cycle ≤ 0.5%.

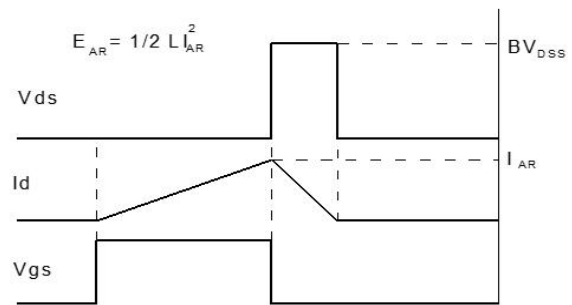
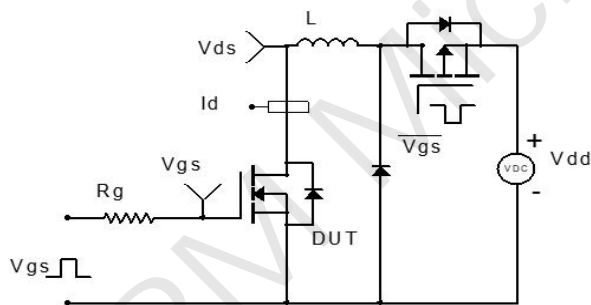
**Test Circuit**



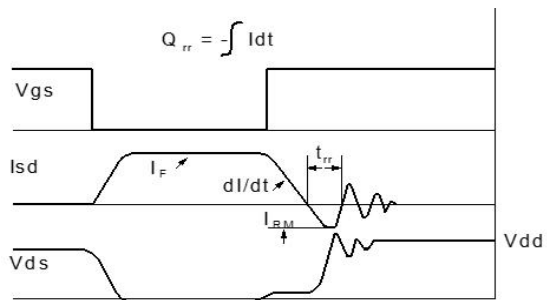
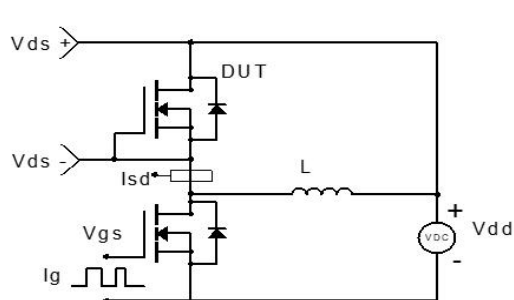
**Figure 1: Gate Charge Test Circuit & Waveform**



**Figure 2: Resistive Switching Test Circuit & Waveform**

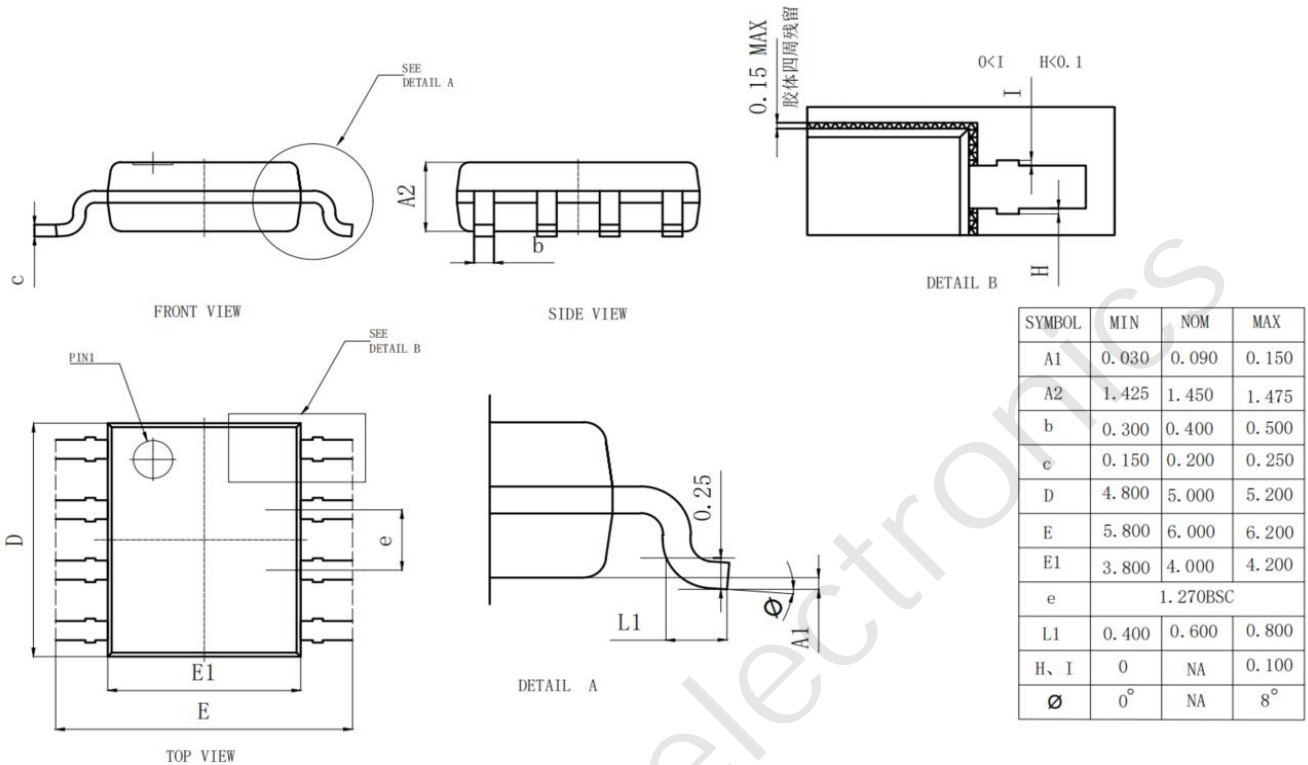


**Figure 3: Unclamped Inductive Switching Test Circuit & Waveform**



**Figure 4: Diode Recovery Test Circuit & Waveform**

### Package Mechanical Data(SOP-8)




### Important Notice

The information presented in datasheets is for reference only. CRM reserves the right to make changes at any time to any products or information herein, without notice.

Customers are responsible for the design and applications, including compliance with all laws, regulations and safety requirements or standards.

“Typical” parameters which provided in datasheets can vary in different applications and actual performance may vary over time. Customers are responsible for doing all necessary testing to minimize the risks associated with their applications and products.

 is a registered trademark of Wuxi CRM Microelectronics Co. , Ltd.

Copyright ©2023 CRM Microelectronics Co. , Ltd. All rights reserved.

### Contact information

For more information, please visit: <http://www.crm-semi.tech>

For sales information, please send an email to: [sales@crm-semi.com](mailto:sales@crm-semi.com)