

Features

- Uses CRM(CQ) advanced SkyMOS3 technology
- Extremely low on-resistance RDS(on)
- Excellent QgxRDS(on) product(FOM)
- Qualified according to JEDEC criteria

Applications

- Motor control and drive
- Battery management
- UPS (Uninterruptible Power Supplies)

Product Summary

V_{DS}	200V
$R_{DS(on)}$	16.5mΩ
I_D	65A

100% Avalanche Tested
100% DVDS Tested

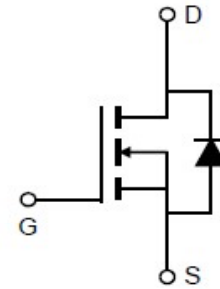
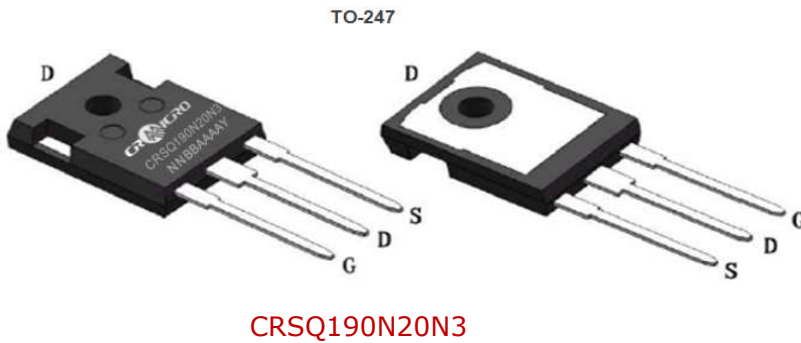
Package Marking and Ordering Information

Part #	Marking	Package	Packing	Reel Size	Tape Width	Qty
CRSQ190N20N3	CRSQ190N20N3	TO-247	Tube	N/A	N/A	30pcs

Absolute Maximum Ratings

Parameter	Symbol	Value	Unit
Drain-source voltage	V_{DS}	200	V
Continuous drain current	I_D	68	A
$T_C = 25^\circ\text{C}$ (Silicon limit)		160	
$T_C = 25^\circ\text{C}$ (Package limit)		43	
$T_C = 100^\circ\text{C}$ (Silicon limit)			
Pulsed drain current ($T_C = 25^\circ\text{C}$, t_p limited by T_{jmax})	$I_{D\ pulse}$	272	A
Avalanche energy, single pulse ($L=0.5\text{mH}$, $R_g=25\Omega$) ^[1]	E_{AS}	121	mJ
Gate-Source voltage	V_{GS}	±20	V
Power dissipation ($T_C = 25^\circ\text{C}$)	P_{tot}	216	W
Operating junction and storage temperature	T_j, T_{stg}	-55...+150	°C

※. Notes:1.EAS is tested at starting $T_j = 25^\circ\text{C}$, $L = 0.5\text{mH}$, $I_{AS} = 22\text{A}$, $V_{gs}=10\text{V}$.

Thermal Resistance

Parameter	Symbol	Max	Unit
Thermal resistance, junction – case.	R_{thJC}	0.58	°C/W
Thermal resistance, junction – ambient(min. footprint)	R_{thJA}	48.0	

Electrical Characteristic (at $T_j = 25\text{ }^\circ\text{C}$, unless otherwise specified)

Parameter	Symbol	Value			Unit	Test Condition
		min.	typ.	max.		

Static Characteristic

Drain-source breakdown voltage	BV_{DSS}	200	220	-	V	$V_{GS}=0V, I_D=250\mu A$
Gate threshold voltage	$V_{GS(th)}$	2.0	3.0	4.0	V	$V_{DS}=V_{GS}, I_D=250\mu A$
Zero gate voltage drain current	I_{DSS}	-	-	1	μA	$V_{DS}=200V, V_{GS}=0V$ $T_j=25^\circ C$ $T_j=150^\circ C$
Gate-source leakage current	I_{GSS}	-	-	± 100	nA	$V_{GS}=\pm 20V, V_{DS}=0V$
Drain-source on-state resistance	$R_{DS(on)}$	-	16.5	19.0	mΩ	$V_{GS}=10V, I_D=30A$
Transconductance	g_{fs}	-	55.4	-	S	$V_{DS}=5V, I_D=30A$

Dynamic Characteristic

Input Capacitance	C_{iss}	-	2746	-	pF	$V_{GS}=0V, V_{DS}=100V,$ $f=1MHz$
Output Capacitance	C_{oss}	-	219	-		
Reverse Transfer Capacitance	C_{rss}	-	14.6	-		
Gate Total Charge	Q_G	-	40.7	-	nC	$V_{GS}=10V, V_{DS}=100V,$ $I_D=30A, f=1MHz$
Gate-Source charge	Q_{gs}	-	17.6	-		
Gate-Drain charge	Q_{gd}	-	7.5	-		
Turn-on delay time	$t_{d(on)}$	-	14	-	ns	$V_{GS}=10V, V_{DD}=100V,$ $R_{G_ext}=3\Omega$
Rise time	t_r	-	57.6	-		
Turn-off delay time	$t_{d(off)}$	-	30.3	-		
Fall time	t_f	-	60.9	-		
Gate resistance	R_G	-	2.1	-	Ω	$V_{GS}=0V, V_{DS}=0V,$ $f=1MHz$

Body Diode Characteristic

Parameter	Symbol	Value			Unit	Test Condition
		min.	typ.	max.		
Body Diode Forward Voltage	V_{SD}	-	0.85	1.3	V	$V_{GS}=0V, I_{SD}=30A$
Body Diode Reverse Recovery Time	t_{rr}	-	112	-	ns	$I_F=30A,$ $dI/dt=100A/us$ $V_{ds}=100V$
Body Diode Reverse Recovery Charge	Q_{rr}	-	503	-	nC	

Typical Performance Characteristics

Fig 1: Output Characteristics

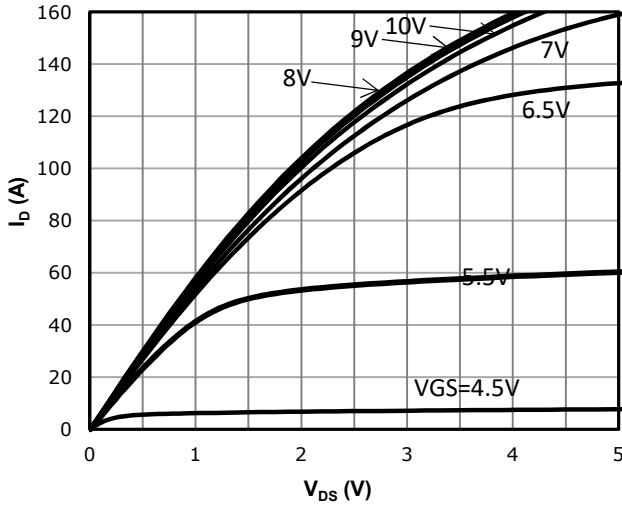

Fig 2: Transfer Characteristics

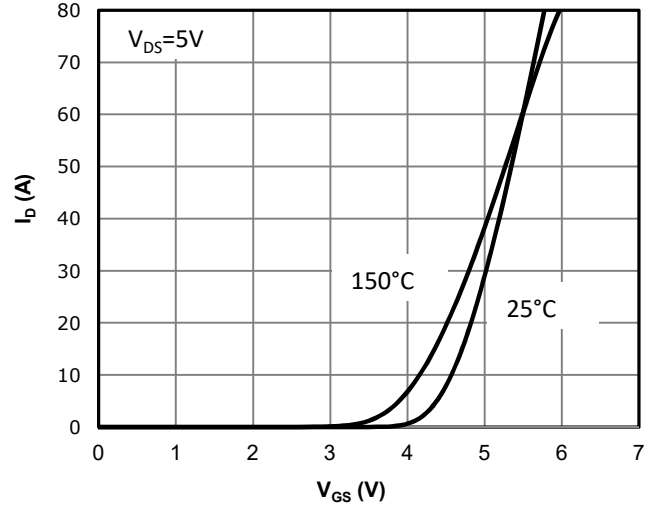

Fig 3: $R_{DS(on)}$ vs Drain Current and Gate Voltage

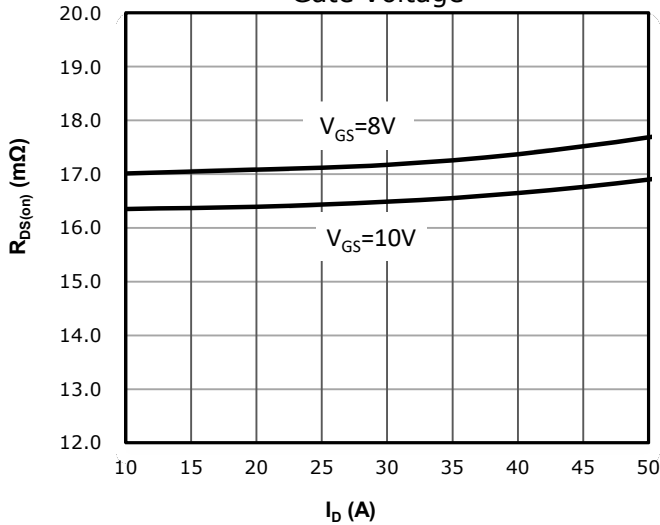

Fig 4: $R_{DS(on)}$ vs Gate Voltage

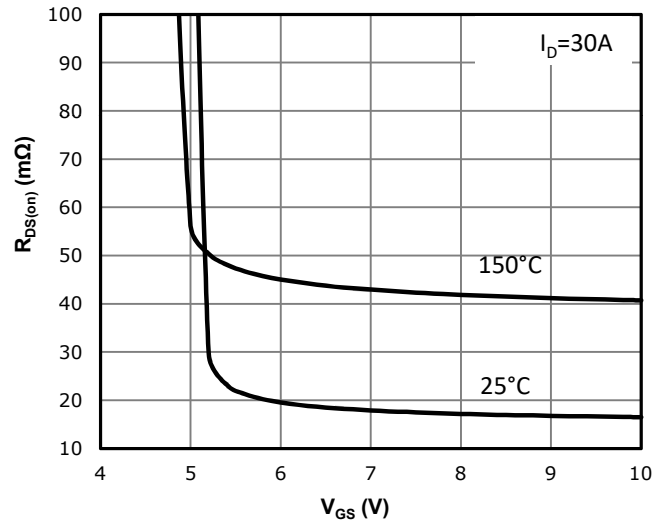

Fig 5: $R_{DS(on)}$ vs. Temperature

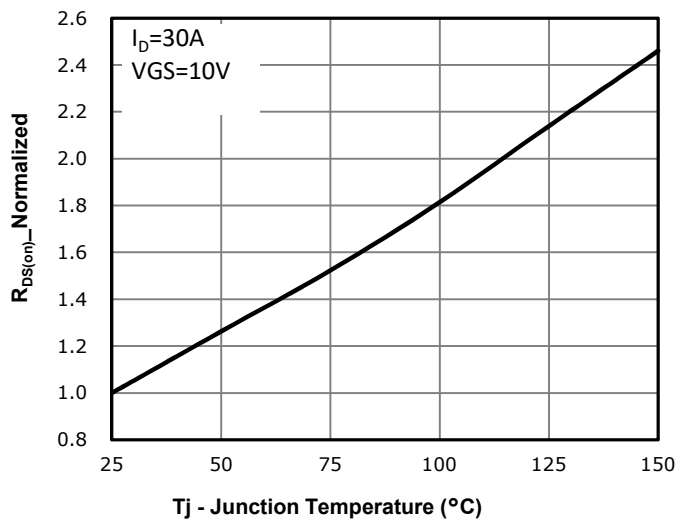

Fig 6: Capacitance Characteristics

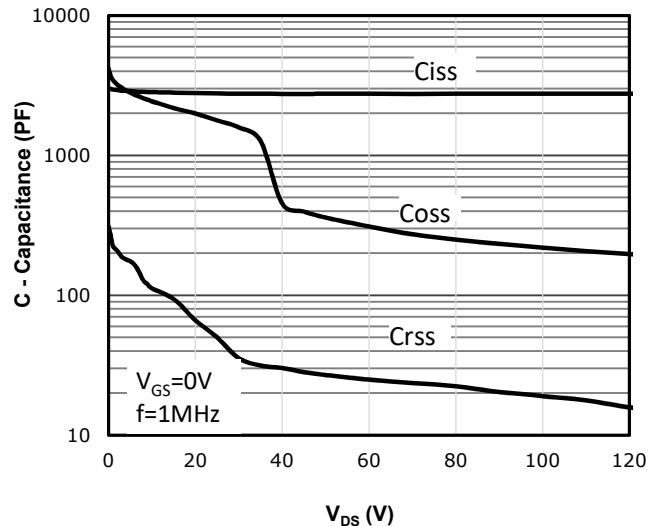

Fig 7: Gate Charge Characteristics

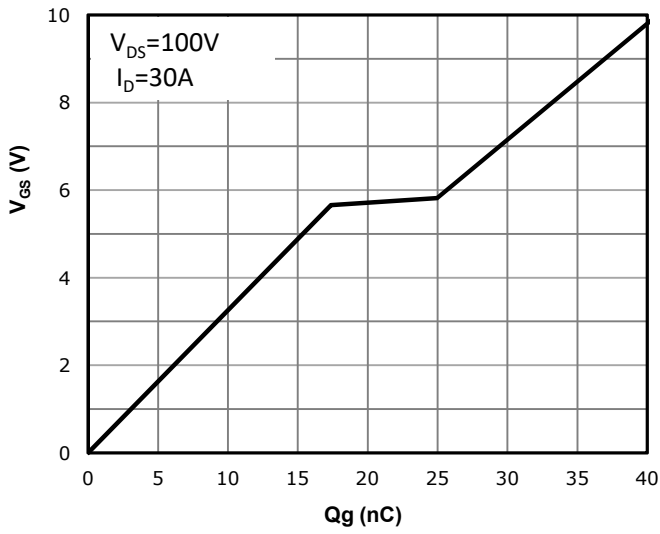

Fig 8: Body-diode Forward Characteristics

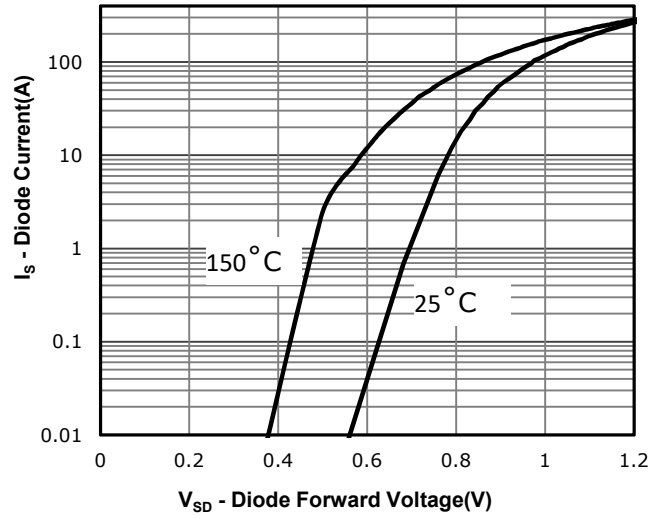

Fig 9: Power Dissipation

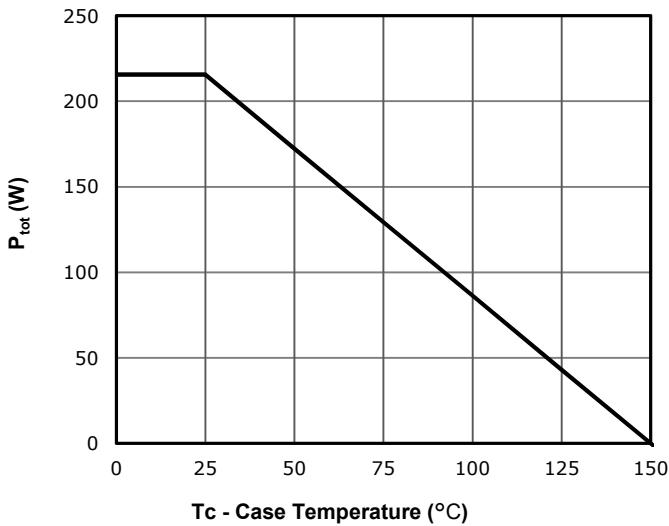

Fig 10: Drain Current Derating

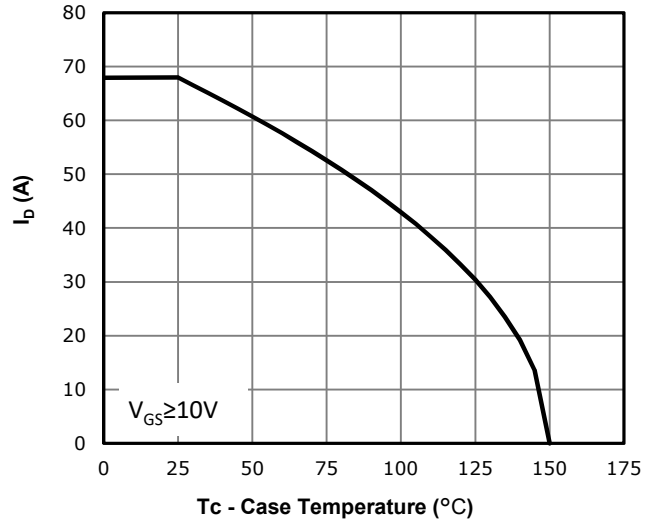

Fig 11: Safe Operating Area

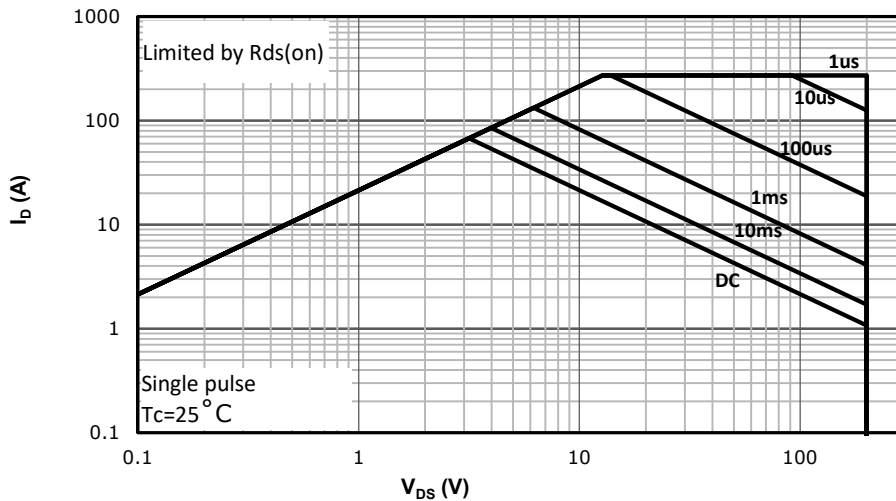
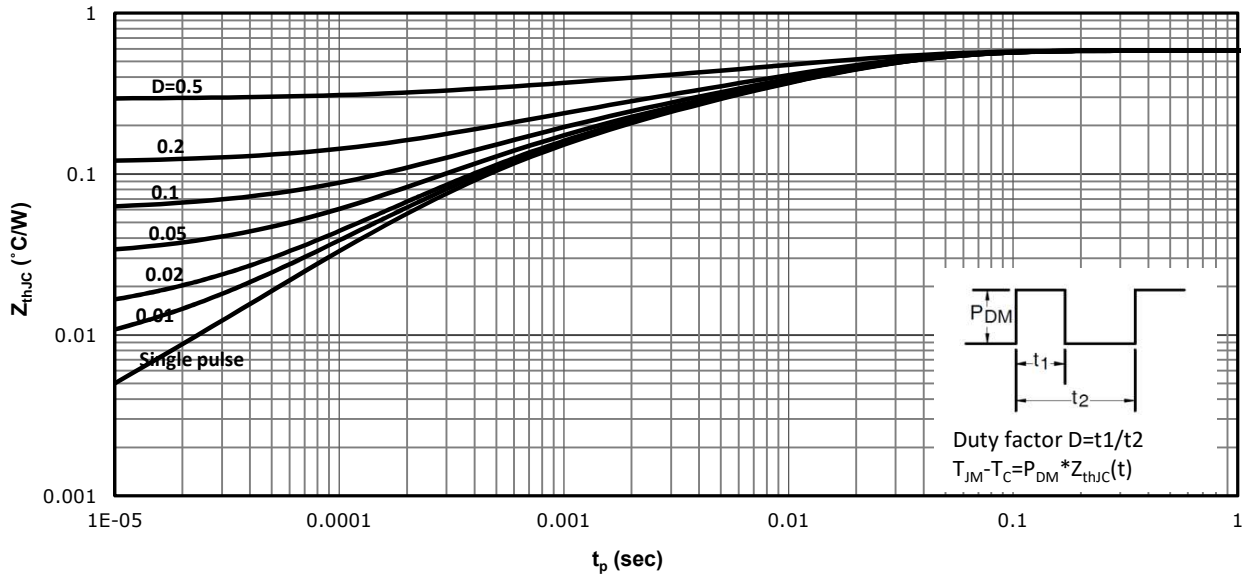
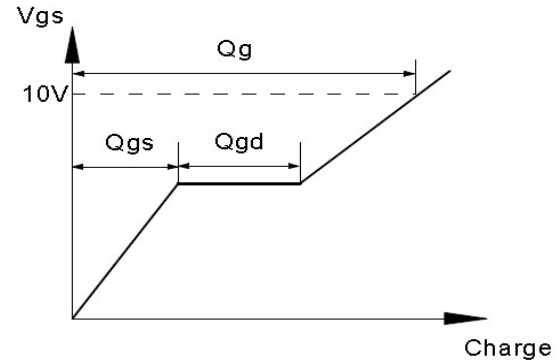
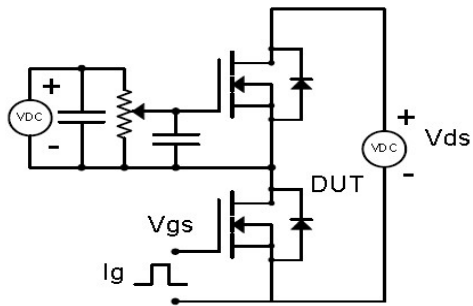

Fig 12: Max. Transient Thermal Impedance



Test Circuit & Waveform

Gate Charge Test Circuit & Waveform



Resistive Switching Test Circuit & Waveforms

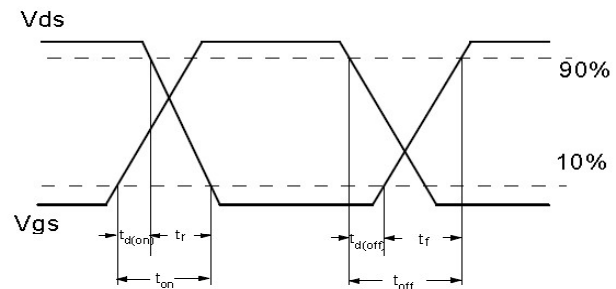
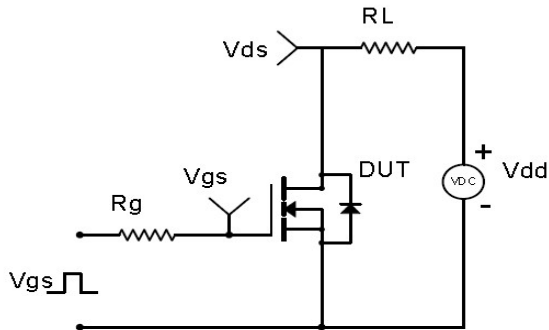

Unclamped Inductive Switching (UIS) Test Circuit & Waveforms

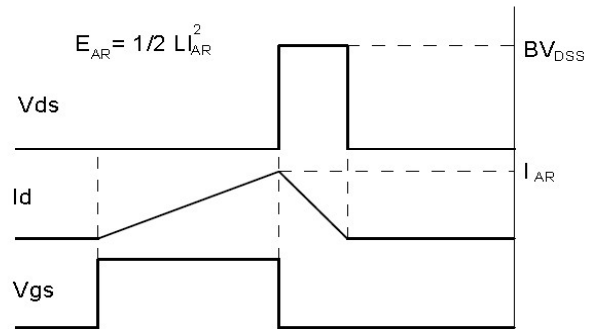
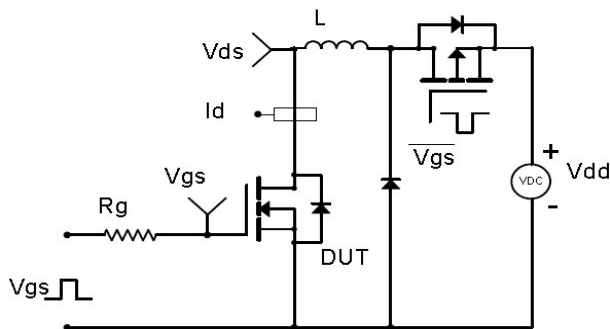

Diode Recovery Test Circuit & Waveforms

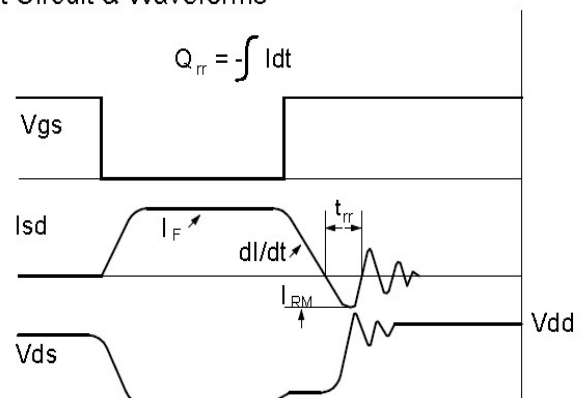
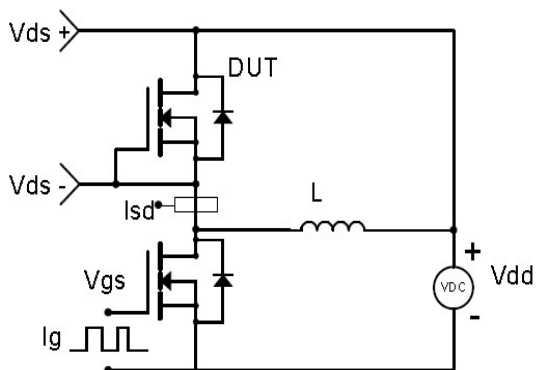

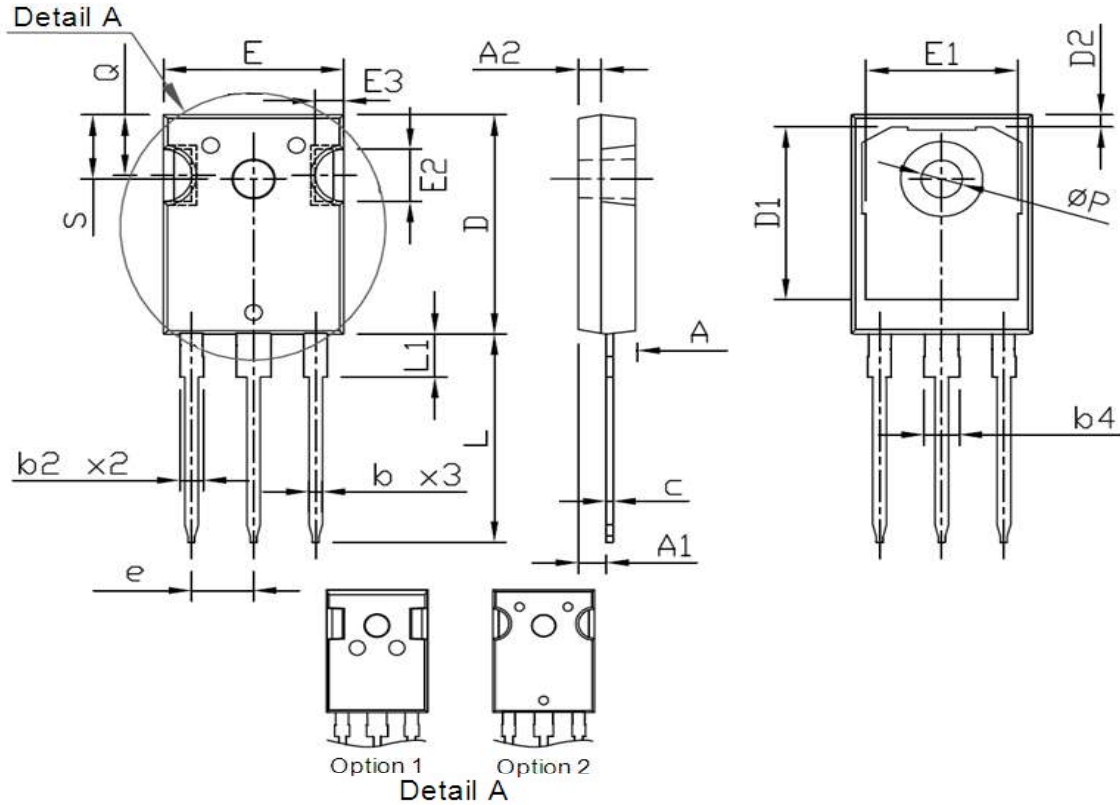
Package Outline: TO-247

Symbol	Dimensions In Millimeters		Dimensions In Inches	
	Min.	Max.	Min.	Max.
A	4.70	5.30	0.185	0.209
A1	2.20	2.60	0.087	0.102
A2	1.50	2.49	0.059	0.098
b	1.04	1.33	0.041	0.052
b2	1.90	2.41	0.075	0.095
b4	2.87	3.43	0.113	0.135
c	0.55	0.70	0.022	0.028
D	20.70	21.30	0.815	0.839
D1	16.25	17.65	0.640	0.695
D2	0.51	1.40	0.020	0.055
e	5.44 BSC.		0.214 BSC.	
E	15.50	16.30	0.610	0.642
E1	13.08	14.16	0.515	0.557
E2	3.80	5.49	0.150	0.216
E3	1.00	2.75	0.039	0.108
L	19.72	20.32	0.776	0.800
L1	3.85	4.50	0.152	0.177
Q	5.25	6.25	0.207	0.246
P	3.50	3.70	0.138	0.146
S	6.04	6.30	0.238	0.248

Revision History

Revision	Date	Major changes
1.0	2023/3/19	Release of Preliminary version.

Disclaimer

Unless otherwise specified in the datasheet, the product is designed and qualified as a standard commercial product and is not intended for use in applications that require extraordinary levels of quality and reliability, such as automotive, aviation/aerospace and life-support devices or systems.

Any and all semiconductor products have certain probability to fail or malfunction, which may result in personal injury, death or property damage. Customer are solely responsible for providing adequate safe measures when design their systems.

CRM(CQ) reserves the right to improve product design, function and reliability without notice.