

Features

- Uses CRM(CQ) advanced SkyMOS1 technology
- Extremely low on-resistance $R_{DS(on)}$
- Excellent $Q_g \times R_{DS(on)}$ product(FOM)
- Qualified according to JEDEC criteria

Applications

- Motor control and drive
- Battery management
- UPS (Uninterruptible Power Supplies)

Product Summary

V_{DS}	70V
$R_{DS(on)}$	4.6mΩ
I_D	120A

100% Avalanche Tested

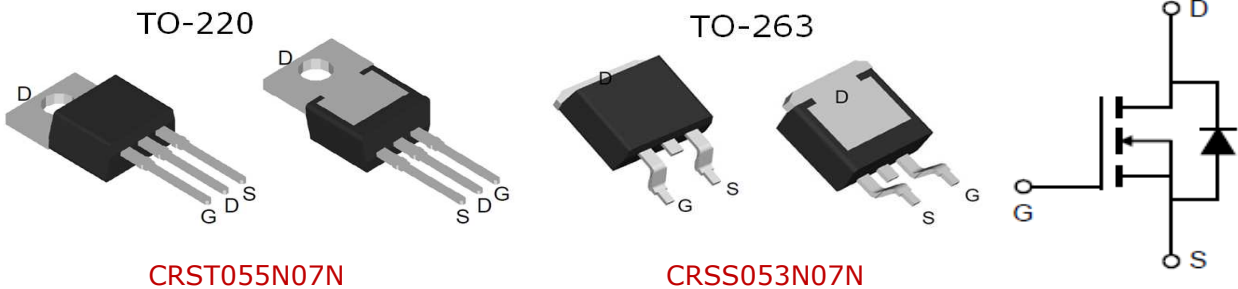

CRST055N07N

CRSS053N07N

Package Marking and Ordering Information

Part #	Marking	Package	Packing	Reel Size	Tape Width	Qty
CRST055N07N	-	TO-220	Tube	N/A	N/A	50pcs
CRSS053N07N	-	TO-263	Tube	N/A	N/A	50pcs

Absolute Maximum Ratings

Parameter	Symbol	Value	Unit
Drain-source voltage	V_{DS}	70	V
Continuous drain current	I_D	123	A
$T_C = 25^\circ\text{C}$ (Silicon limit)		120	
$T_C = 25^\circ\text{C}$ (Package limit)		78	
$T_C = 100^\circ\text{C}$ (Silicon limit)			
Pulsed drain current ($T_C = 25^\circ\text{C}$, t_p limited by T_{jmax})	$I_{D\ pulse}$	480	A
Avalanche energy, single pulse ($L=0.5\text{mH}$, $R_g=25\ \Omega$) ^[1]	E_{AS}	132	mJ
Gate-Source voltage	V_{GS}	± 20	V
Power dissipation ($T_C = 25^\circ\text{C}$)	P_{tot}	136	W
Operating junction and storage temperature	T_j, T_{stg}	-55...+150	$^\circ\text{C}$

※. Notes: 1.EAS is tested at starting $T_j = 25^\circ\text{C}$, $L = 0.5\text{mH}$, $I_{AS} = 23.0\text{A}$, $V_{GS} = 10\text{V}$.

Thermal Resistance

Parameter	Symbol	Max	Unit
Thermal resistance, junction – case.	R_{thJC}	0.92	°C/W
Thermal resistance, junction – ambient(min. footprint)	R_{thJA}	62	

Electrical Characteristic (at $T_j = 25\text{ }^\circ\text{C}$, unless otherwise specified)

Parameter	Symbol	Value			Unit	Test Condition
		min.	typ.	max.		

Static Characteristic

Drain-source breakdown voltage	BV_{DSS}	70	-	-	V	$V_{GS}=0V, I_D=250\mu A$
Gate threshold voltage	$V_{GS(th)}$	2	3	4	V	$V_{DS}=V_{GS}, I_D=250\mu A$
Zero gate voltage drain current	I_{DSS}	-	0.02	1	μA	$V_{DS}=70V, V_{GS}=0V$ $T_j=25^\circ C$ $T_j=125^\circ C$
Gate-source leakage current	I_{GSS}	-	± 10	± 100	nA	$V_{GS}=\pm 20V, V_{DS}=0V$
Drain-source on-state resistance	$R_{DS(on)}$	-	4.6	5.5	$m\Omega$	$V_{GS}=10V, I_D=40A$ TO-220 TO-263
Transconductance	g_{fs}	-	88.1	-	S	$V_{DS}=5V, I_D=40A$

Dynamic Characteristic

Input Capacitance	C_{iss}	-	3400	-	pF	$V_{GS}=0V, V_{DS}=35V,$ $f=1MHz$
Output Capacitance	C_{oss}	-	697	-		
Reverse Transfer Capacitance	C_{rss}	-	45	-		
Gate Total Charge	Q_G	-	53.4	-	nC	$V_{GS}=10V, V_{DS}=35V,$ $I_D=40A, f=1MHz$
Gate-Source charge	Q_{gs}	-	20.1	-		
Gate-Drain charge	Q_{gd}	-	11.6	-		
Turn-on delay time	$t_{d(on)}$	-	17.4	-	ns	$V_{GS}=10V, V_{DD}=35V,$ $R_{G_ext}=2.7\Omega$
Rise time	t_r	-	63.7	-		
Turn-off delay time	$t_{d(off)}$	-	34.9	-		
Fall time	t_f	-	51.4	-		
Gate resistance	R_G	-	1.85	-	Ω	$V_{GS}=0V, V_{DS}=0V,$ $f=1MHz$

Body Diode Characteristic

Parameter	Symbol	Value			Unit	Test Condition
		min.	typ.	max.		
Body Diode Forward Voltage	V_{SD}	-	0.91	1.3	V	$V_{GS}=0V, I_{SD}=40A$
Body Diode Reverse Recovery Time	t_{rr}	-	52.2	-	ns	$I_F=40A,$ $dI/dt=100A/\mu s$
Body Diode Reverse Recovery Charge	Q_{rr}	-	59.5	-	nC	

Typical Performance Characteristics

Fig 1: Output Characteristics

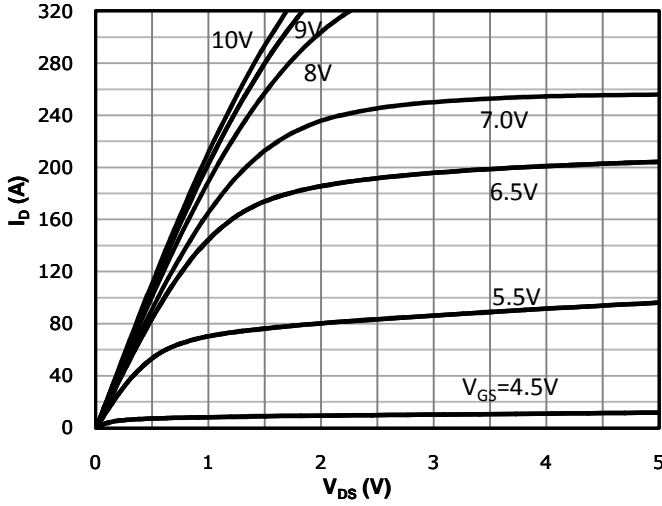

Fig 2: Transfer Characteristics

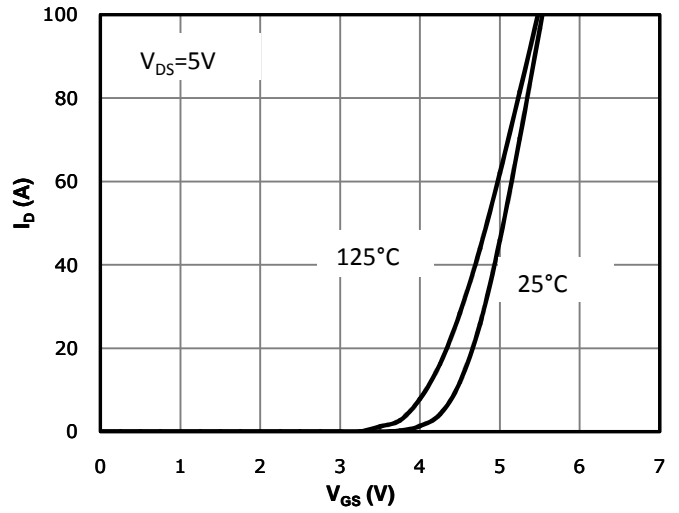

Fig 3: $R_{DS(on)}$ vs Drain Current and Gate Voltage

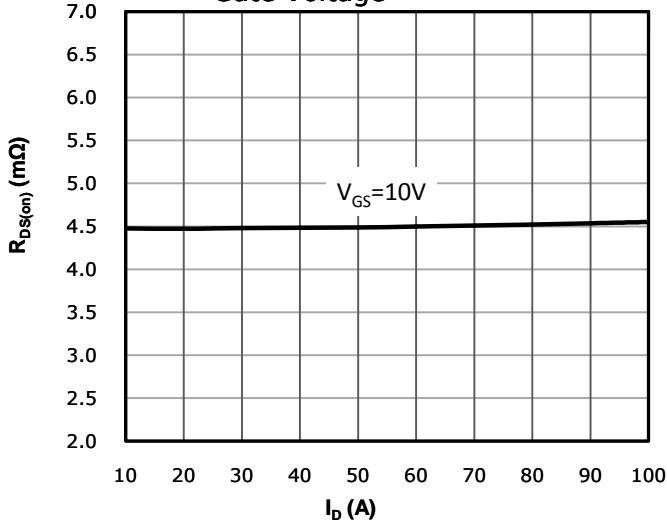

Fig 4: $R_{DS(on)}$ vs Gate Voltage

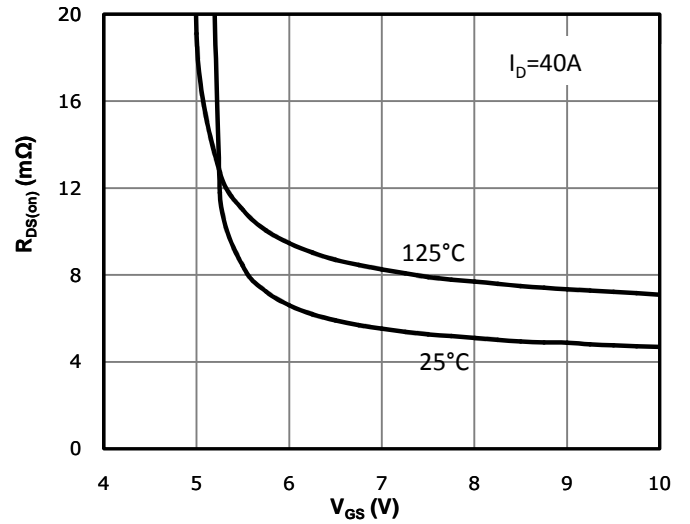

Fig 5: $R_{DS(on)}$ vs. Temperature

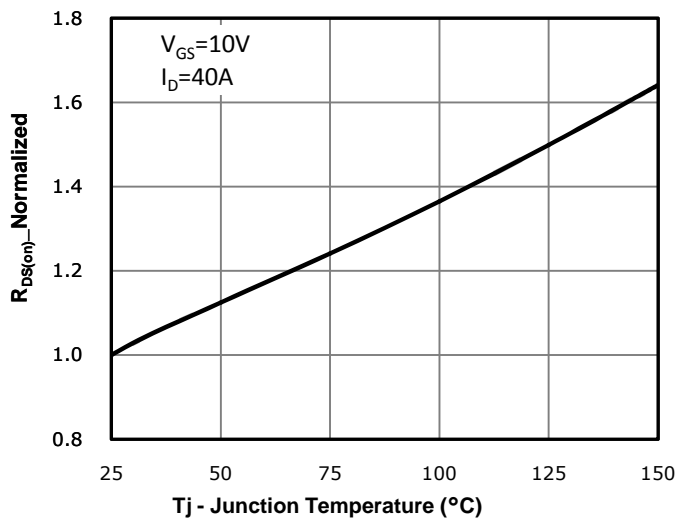

Fig 6: Capacitance Characteristics

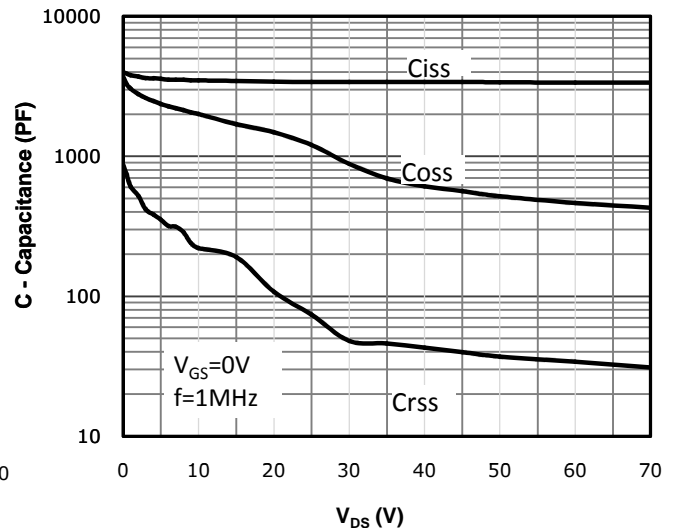

Fig 7: Gate Charge Characteristics

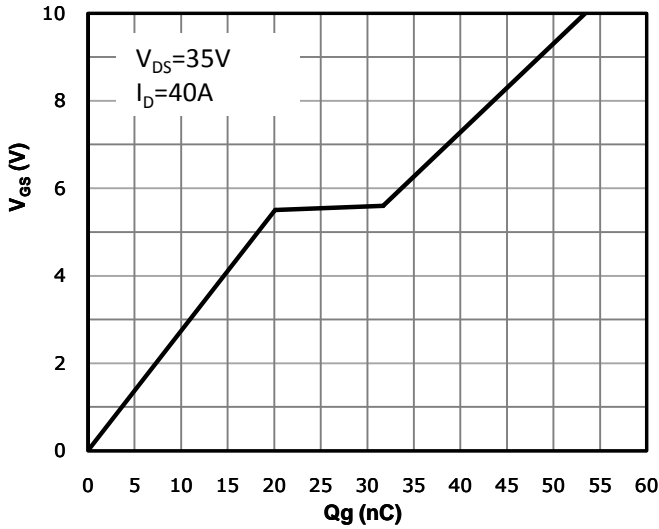

Fig 8: Body-diode Forward Characteristics

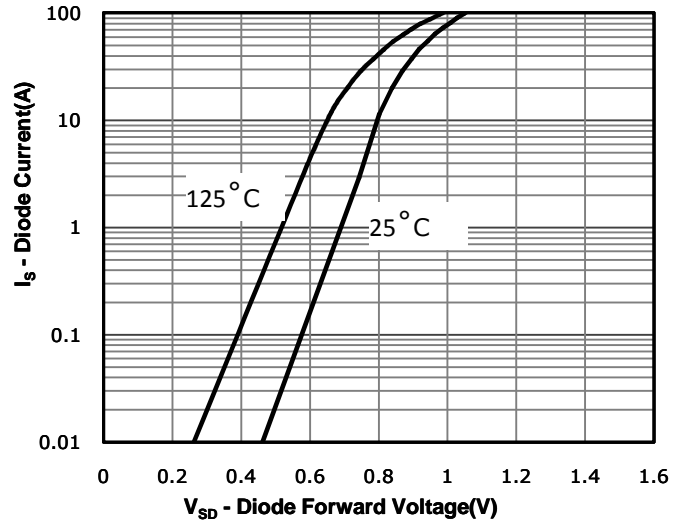

Fig 9: Power Dissipation

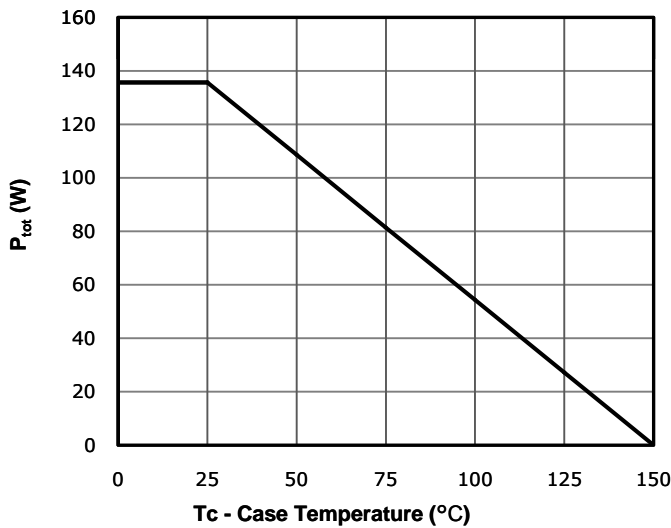

Fig 10: Drain Current Derating

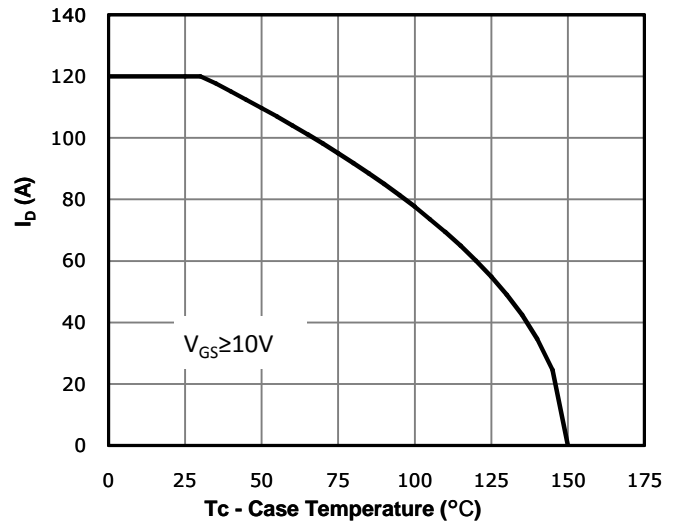

Fig 11: Safe Operating Area

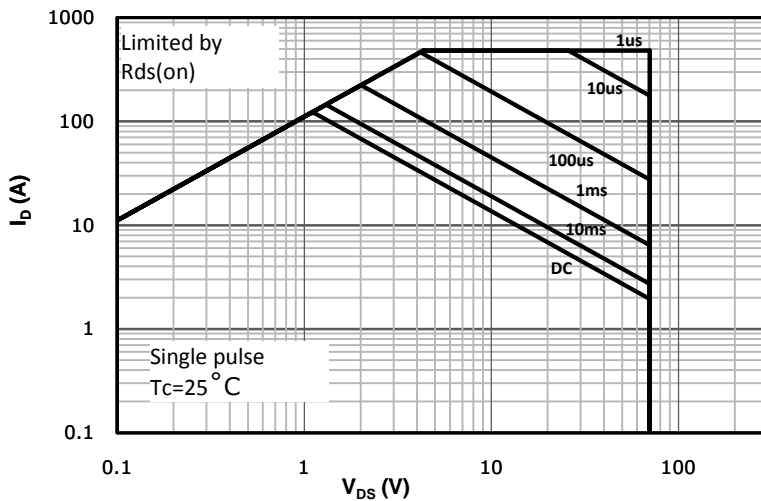
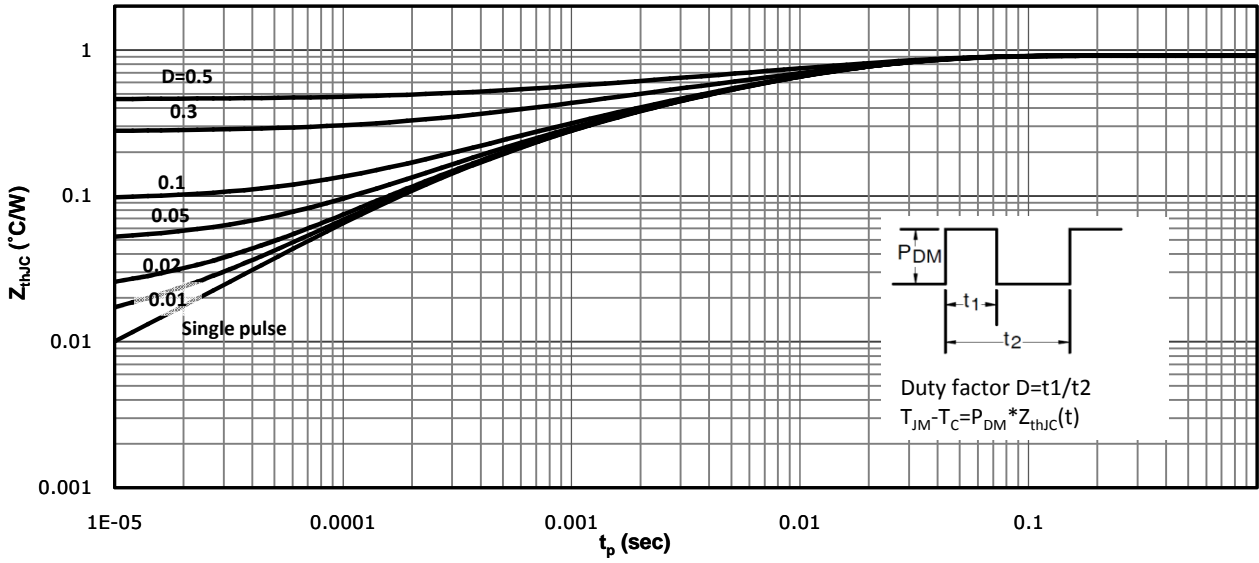
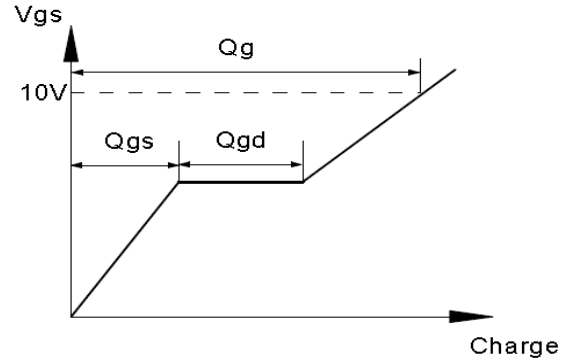
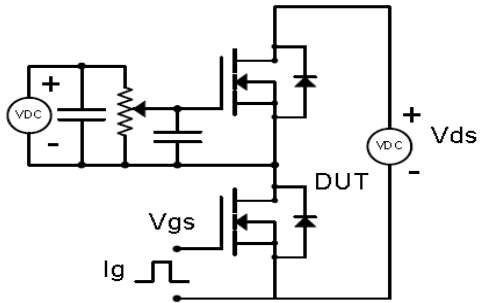

Fig 12: Max. Transient Thermal Impedance



Test Circuit & Waveform

Gate Charge Test Circuit & Waveform



Resistive Switching Test Circuit & Waveforms

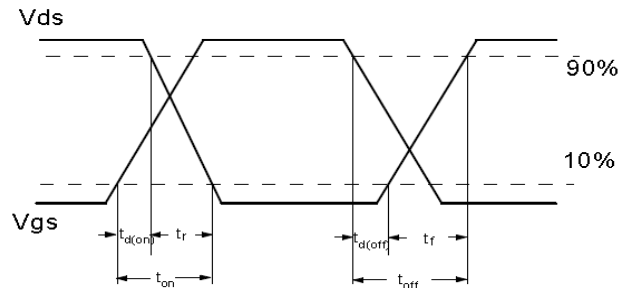
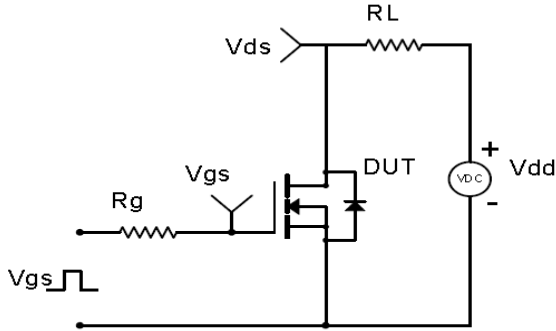

Unclamped Inductive Switching (UIS) Test Circuit & Waveforms

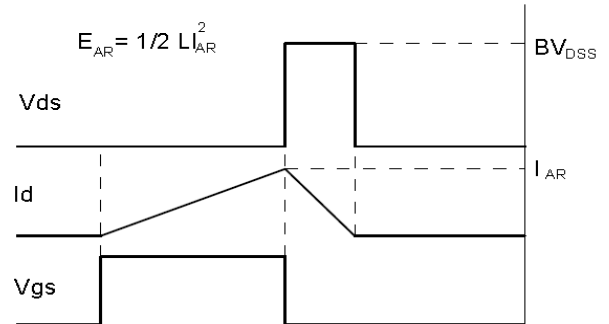
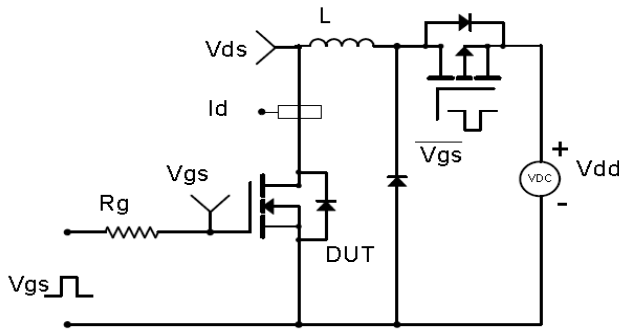

Diode Recovery Test Circuit & Waveforms

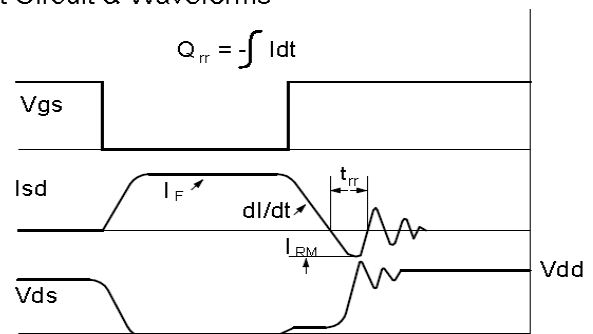
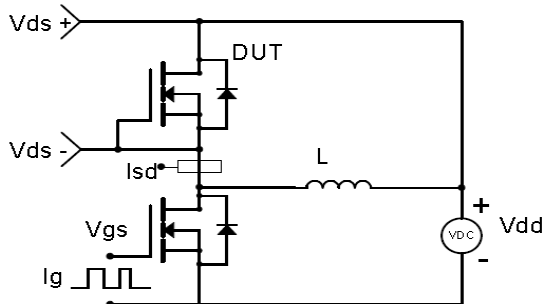

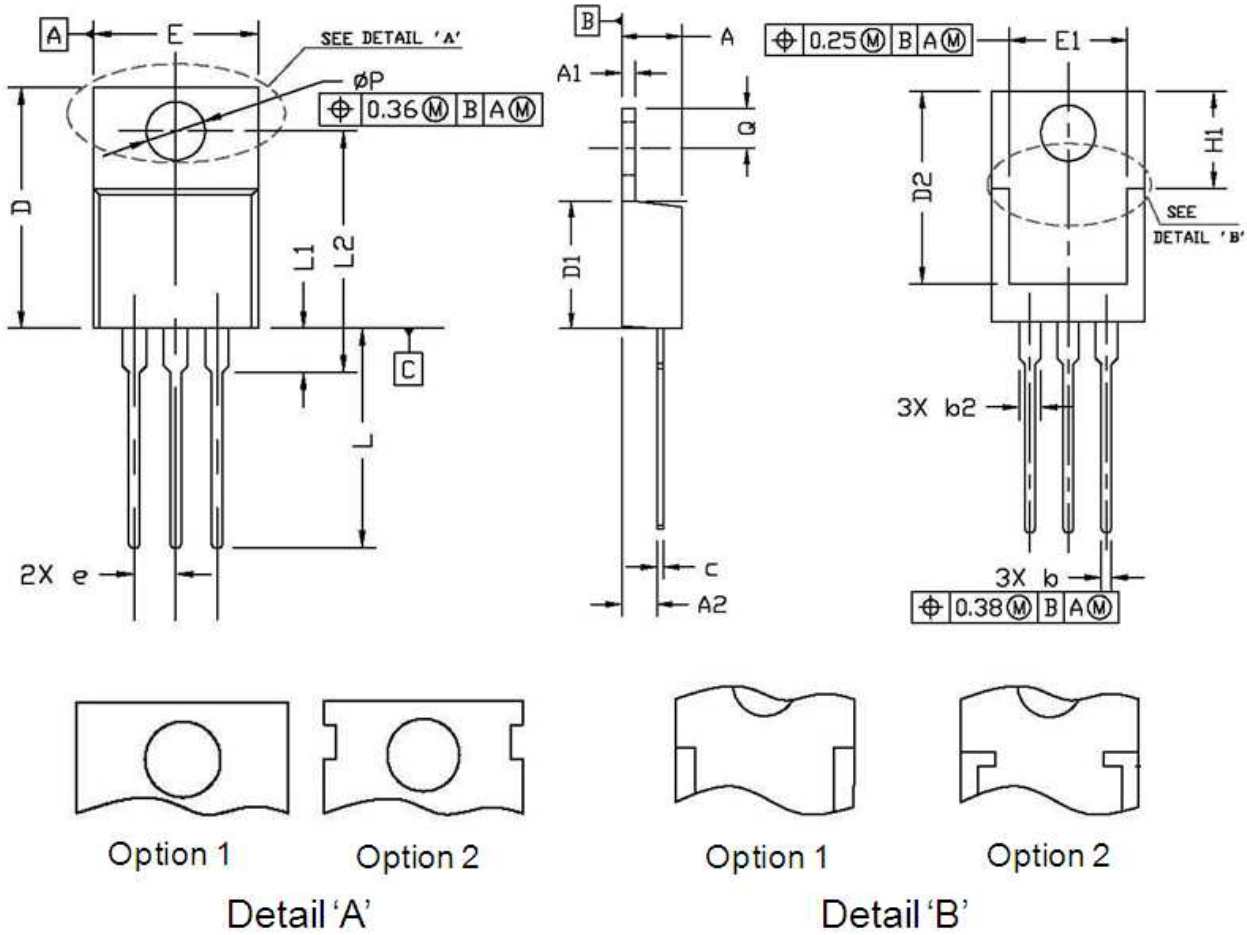
Package Outline: TO-220-3L

Symbol	Dimensions In Millimeters		Dimensions In Inches	
	Min.	Max.	Min.	Max.
A	4.30	4.80	0.169	0.189
A1	1.20	1.45	0.047	0.057
A2	2.20	2.90	0.087	0.114
b	0.69	0.95	0.027	0.037
b2	1.00	1.60	0.039	0.063
c	0.33	0.65	0.013	0.026
D	14.70	16.20	0.579	0.638
D1	8.59	9.65	0.338	0.380
D2	11.75	13.60	0.463	0.535
e	2.54 BSC.		0.100 BSC.	
E	9.60	10.60	0.378	0.417
E1	7.00	8.46	0.276	0.333
H1	6.20	7.00	0.244	0.276
L	12.60	14.80	0.496	0.583
L1	2.70	3.80	0.106	0.150
L2	12.13	16.50	0.478	0.650
Q	2.40	3.10	0.094	0.122
P	3.50	3.90	0.138	0.154

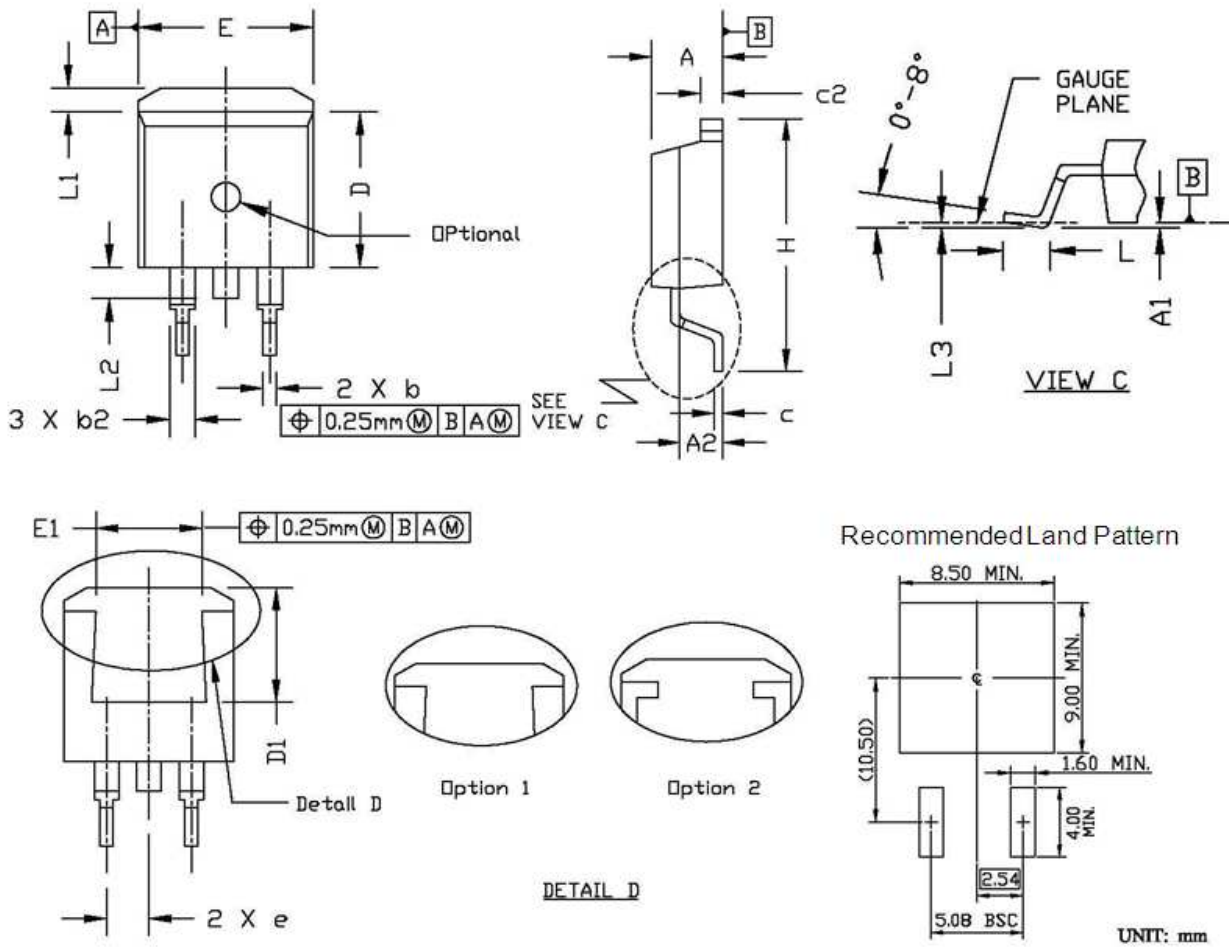
Package Outline: TO-263

Symbol	Dimensions In Millimeters		Dimensions In Inches	
	Min.	Max.	Min.	Max.
A	4.30	4.86	0.169	0.191
A1	0.00	0.25	0.000	0.010
A2	2.34	2.79	0.092	0.110
b	0.68	0.94	0.027	0.037
b2	1.15	1.35	0.045	0.053
c	0.33	0.65	0.013	0.026
c2	1.17	1.40	0.046	0.055
D	8.38	9.45	0.330	0.372
D1	6.90	8.17	0.272	0.322
e	2.54 BSC.		0.100 BSC.	
E	9.78	10.50	0.385	0.413
E1	6.50	8.60	0.256	0.339
H	14.61	15.88	0.575	0.625
L	2.24	3.00	0.088	0.118
L1	0.70	1.60	0.028	0.063
L2	1.00	1.78	0.039	0.070
L3	0.00	0.25	0.000	0.010

Revision History

Revision	Date	Major changes
1.0	2018-11-05	preliminary version.
2.0	2018-12-05	Official version.(Revise Id Package Limit)
3.0	2019-06-04	Supplement package outline info.
4.0	2019-08-26	Update Rthjc&Id&Pd&Zth;

Disclaimer

Unless otherwise specified in the datasheet, the product is designed and qualified as a standard commercial product and is not intended for use in applications that require extraordinary levels of quality and reliability, such as automotive, aviation/aerospace and life-support devices or systems.

Any and all semiconductor products have certain probability to fail or malfunction, which may result in personal injury, death or property damage. Customer are solely responsible for providing adequate safe measures when design their systems.

CRM(CQ) reserves the right to improve product design, function and reliability without notice.