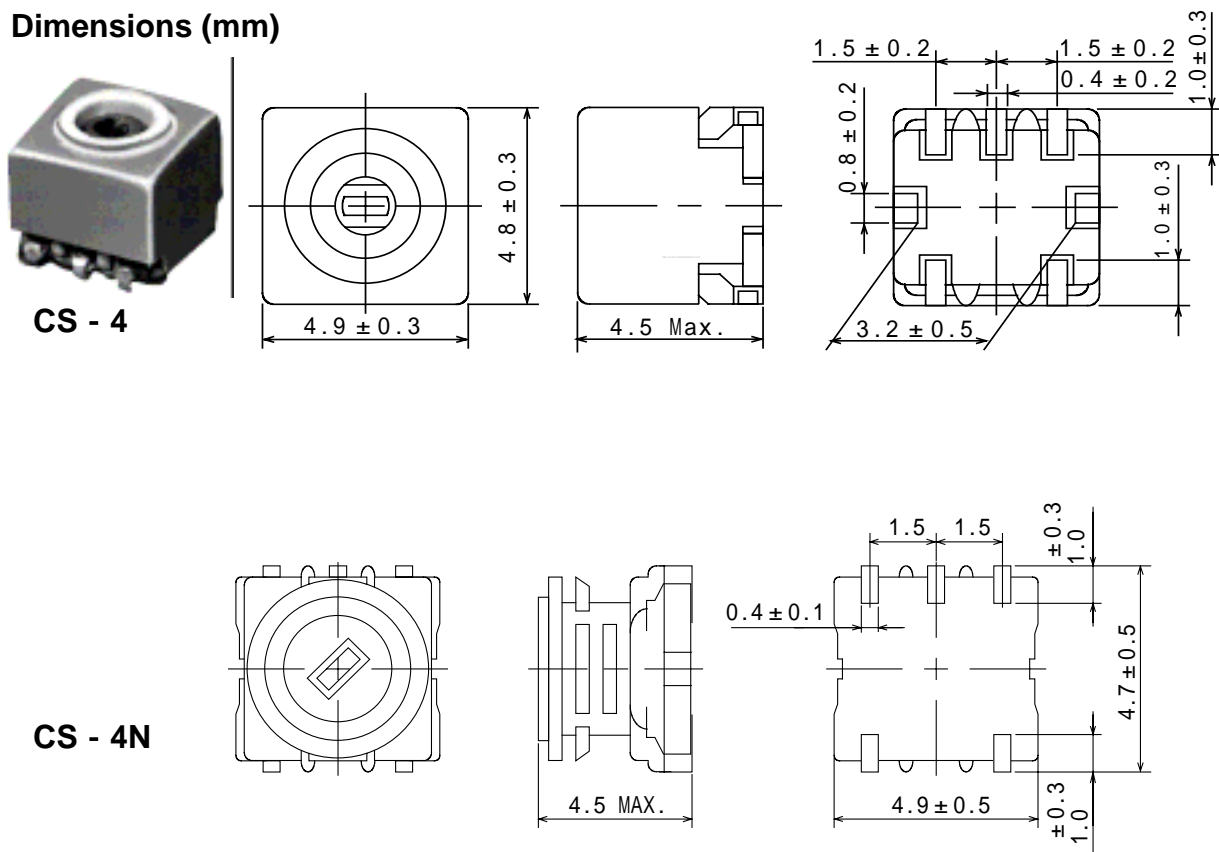

**Type: CS-4, CS-4N**
**Product Description**

- 5.2 × 5.1mm Max.(L × W), 4.5mm Max. Height. (CS-4)
- 5.4 × 5.2mm Max.(L × W), 4.5mm Max. Height. (CS-4N)
- Inductance: 1.0 μ H Max.
- Operating frequency:300MHz Max.
- In addition to the reference versions of parameters shown here,custom designs are available to meet your exact requirements

**Feature**

- Variable type.
- Both shielded(CS-4) and unshielded(CS-4N) types are available.
- RoHS Compliance

**Dimensions (mm)**

- \* Dimension does not include solder used on coil.
- \* Pin pitch should be measured at the root of terminal.
- \* Dimensions without tolerance are approx.

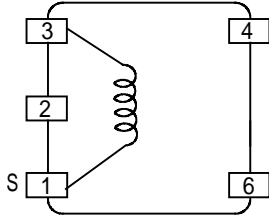
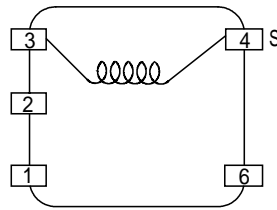
**Type: CS-4, CS-4N**
**Connection (Bottom View)**
**CS-4**

**CS-4N**

“ S ” is winding start.

**Specification (CS-4)** (Part No. 5202-T293)

Item	( 1 - 3 )	Measuring Condition
Tuning capacitance	11.5 p F $\pm 2\%$ Within	1 0 0 M H z
Unloaded Qu	35 Min.	1 0 0 M H z

**Specification (CS-4N)** (Part No. 5203-T045)

Item	( 3 - 4 )	Measuring Condition
Tuning capacitance	54.3 p F $\pm 1\%$ Within	1 0 0 M H z
Unloaded Qu	45 Min.	1 0 0 M H z