



CS10N06 BE-G

General Description:

CS10N06 BE-G, the silicon N-channel Enhanced VDMOSFETs, is obtained by the high density Trench technology which reduce the conduction loss, improve switching performance and enhance the avalanche energy. This device is suitable for use as a load switch and PWM applications.. The package form is SOP-8, which accords with the RoHS standard.

Features:

- **Fast Switching**
- **Low ON Resistance**($R_{dson} \leq 16 \text{ m}\Omega$)
- **Low Gate Charge**
- **Low Reverse transfer capacitances**
- **100% Single Pulse avalanche energy Test**

Applications:

Power switch circuit of adaptor and charger;
LED backlight driver.

V_{DSS}	60	V
I_D	10	A
P_D	3.1	W
$R_{DS(ON)Typ}$	12.5	m Ω

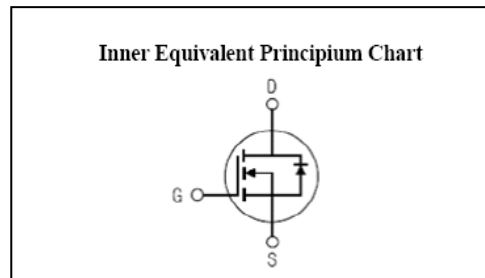
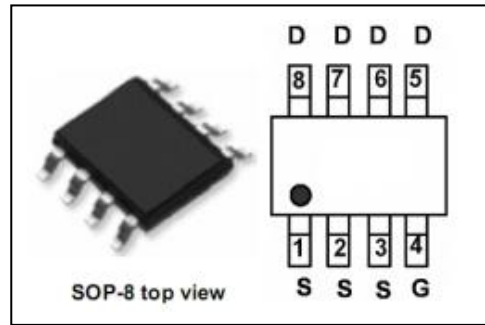

Absolute ($T_A = 25^\circ\text{C}$ unless otherwise specified)

Symbol	Parameter	Rating	Units
V_{DSS}	Drain-to-Source Voltage	60	V
I_D	Continuous Drain Current	10	A
	Continuous Drain Current $T_A = 100^\circ\text{C}$	6.3	A
I_{DM}^{a1}	Pulsed Drain Current	40	A
V_{GS}	Gate-to-Source Voltage	± 20	V
E_{AS}^{a2}	Avalanche Energy	121	mJ
P_D	Power Dissipation	3.1	W
	Derating Factor above 25°C	0.025	W/ $^\circ\text{C}$
T_J, T_{stg}	Operating Junction and Storage Temperature Range	150, -55 to 150	$^\circ\text{C}$

Electrical Characteristics ($T_A = 25^\circ\text{C}$ unless otherwise specified):

OFF Characteristics						
Symbol	Parameter	Test Conditions	Rating			Units
			Min.	Typ.	Max.	
V_{DSS}	Drain to Source Breakdown Voltage	$V_{GS}=0V, I_D=250\mu A$	60	--	--	V
I_{DSS}	Drain to Source Leakage Current	$V_{DS}=60V, V_{GS}=0V, T_A=25^\circ\text{C}$	--	--	1	μA
		$V_{DS}=48V, V_{GS}=0V, T_A=125^\circ\text{C}$	--	--	100	
$I_{GSS(F)}$	Gate to Source Forward Leakage	$V_{GS}=20V$	--	--	100	nA
$I_{GSS(R)}$	Gate to Source Reverse Leakage	$V_{GS}=-20V$	--	--	-100	nA

ON Characteristics						
Symbol	Parameter	Test Conditions	Rating			Units
			Min.	Typ.	Max.	
$R_{DS(ON)}$	Drain-to-Source On-Resistance	$V_{GS}=10V, I_D=10A$	--	12.5	16	$m\Omega$
		$V_{GS}=4.5V, I_D=8A$	--	15	20	$m\Omega$
$V_{GS(TH)}$	Gate Threshold Voltage	$V_{DS} = V_{GS}, I_D = 250\mu A$	1.0	1.5	2.0	V
Pulse width $t_p \leq 300\mu s, \delta \leq 2\%$						

Dynamic Characteristics						
Symbol	Parameter	Test Conditions	Rating			Units
			Min.	Typ.	Max.	
R_g	Gate resistance	$V_{GS}=0V, V_{DS}=0V, f=1\text{MHz}$	--	3.2	--	Ω
C_{iss}	Input Capacitance	$V_{GS} = 0V, V_{DS} = 30V, f = 1.0\text{MHz}$	--	1876	--	pF
C_{oss}	Output Capacitance		--	135	--	
C_{rss}	Reverse Transfer Capacitance		--	102	--	

Resistive Switching Characteristics						
Symbol	Parameter	Test Conditions	Rating			Units
			Min.	Typ.	Max.	
$t_{d(ON)}$	Turn-on Delay Time	$V_{GS}=10V, R_g=3\Omega, V_{DD}=30V, I_D=10A$	--	13.1	--	ns
t_r	Rise Time		--	25.1	--	
$t_{d(OFF)}$	Turn-Off Delay Time		--	60.8	--	
t_f	Fall Time		--	9.2	--	
Q_g	Total Gate Charge	$I_D=10A, V_{DD}=30V, V_{GS}=10V$	--	43.45	--	nC
Q_{gs}	Gate to Source Charge		--	5.7	--	
Q_{gd}	Gate to Drain ("Miller") Charge		--	11.9	--	

Source-Drain Diode Characteristics						
Symbol	Parameter	Test Conditions	Rating			Units
			Min.	Typ.	Max.	
I_S	Continuous Source Current (Body Diode)	$T_A = 25^\circ\text{C}$	--	--	10	A
I_{SM}	Maximum Pulsed Current (Body Diode)		--	--	40	A
V_{SD}	Diode Forward Voltage	$I_S = 10\text{A}, V_{GS} = 0\text{V}$	--	--	1.2	V
t_{rr}	Reverse Recovery Time	$di/dt = 100\text{A}/\mu\text{s}$	--	29	--	ns
Q_{rr}	Reverse Recovery Charge	$I_F = 10\text{A}$	--	21	--	nC
Pulse width $t_p \leq 300 \mu\text{s}$, $\delta \leq 2\%$						

Symbol	Parameter	Max.	Units
$R_{\theta JA}$	Junction-to-Ambient	40	$^\circ\text{C}/\text{W}$

^{a1}: Repetitive rating; pulse width limited by maximum junction temperature

^{a2}: $L = 0.5\text{mH}, V_{DD} = 30\text{V}, I_{AS} = 22\text{A}$ Start $T_J = 25^\circ\text{C}$

^{a3}: Recommend soldering temperature defined by IPC/JEDEC J-STD 020

Characteristics Curve:

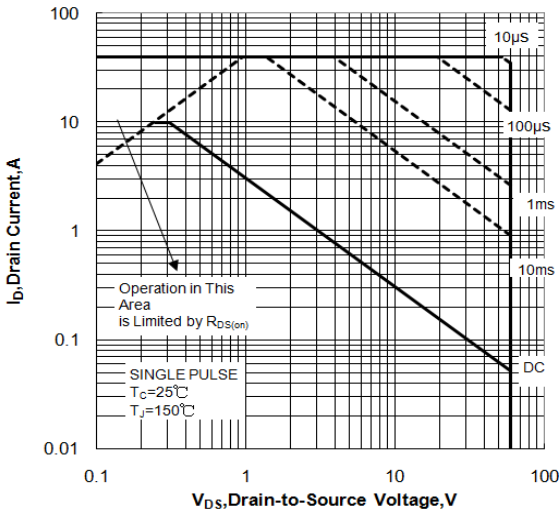

Figure 1. Maximum Safe Operating Area

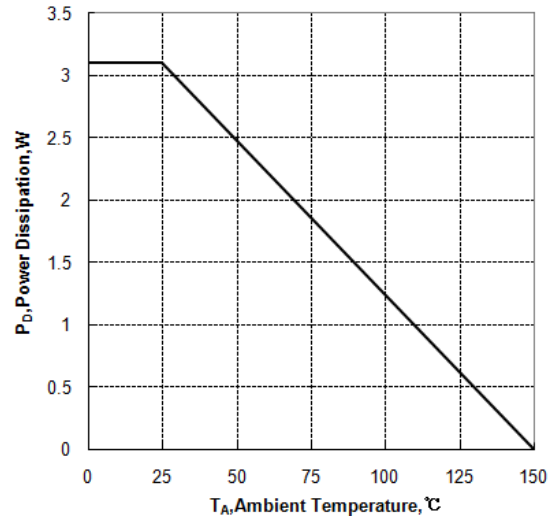

Figure 2. Maximum Power Dissipation vs Ambient Temperature

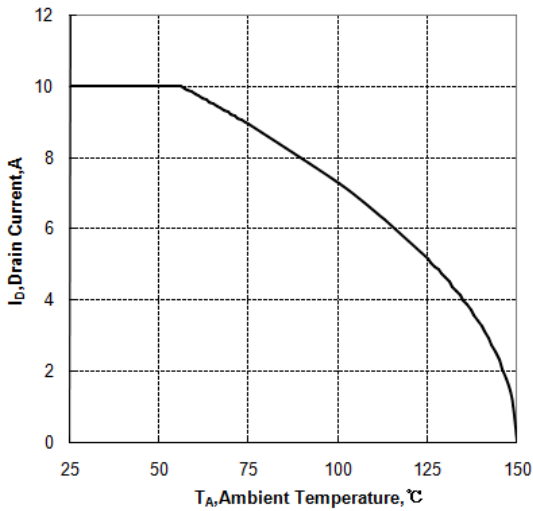

Figure 3. Maximum Continuous Drain Current vs Ambient Temperature

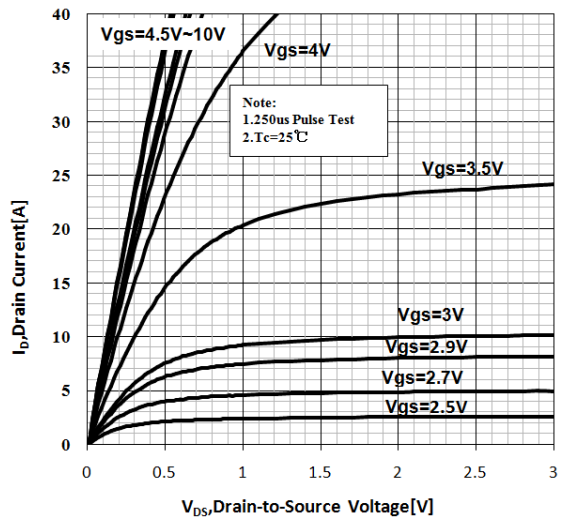

Figure 4. Typical output Characteristics

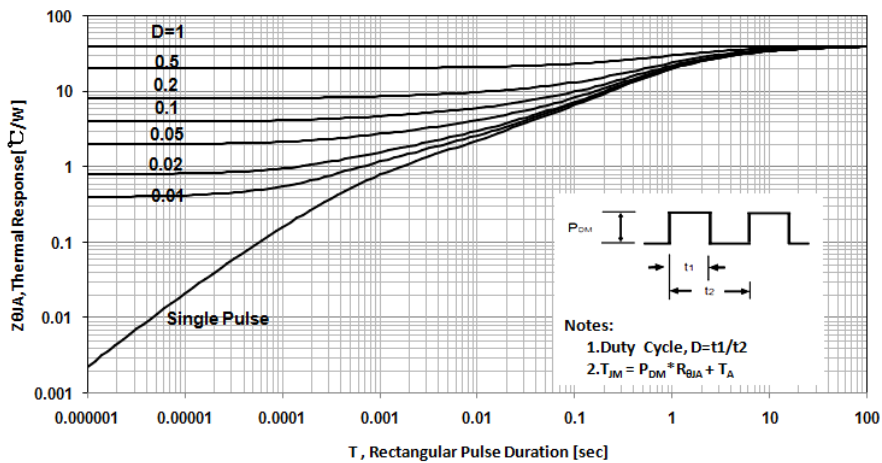

Figure 5 Maximum Effective Thermal Impedance, Junction to Ambient

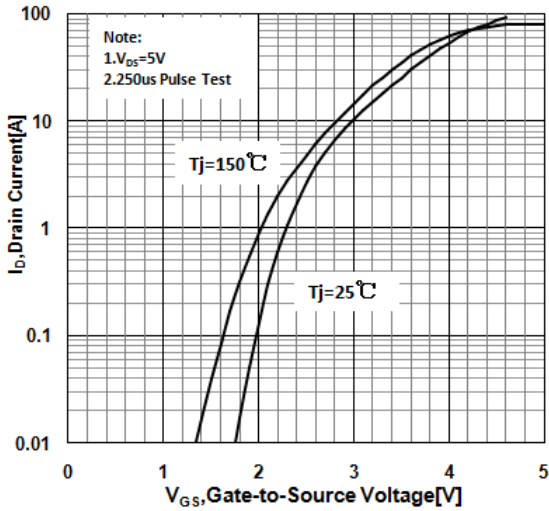

Figure 6 Typical Transfer Characteristics

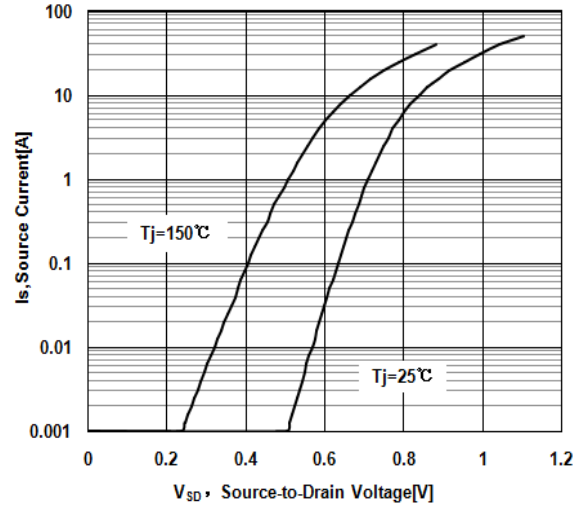

Figure 7 Typical Body Diode Transfer Characteristics

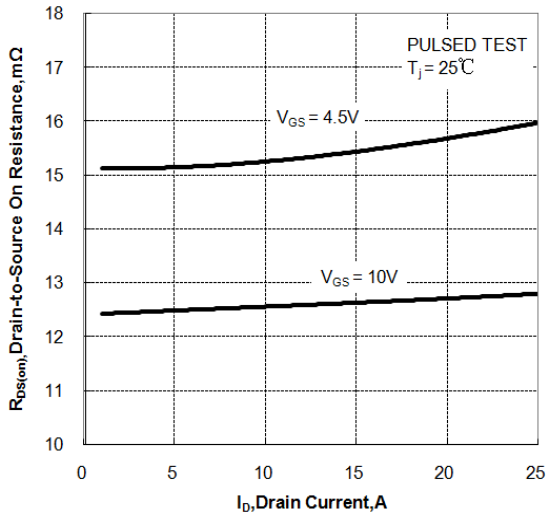

Figure 8. Drain-to-Source On Resistance vs Drain Current

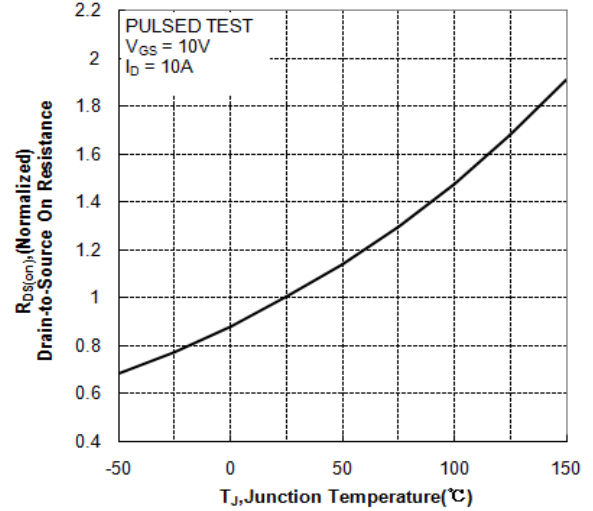

Figure 9. Normalized On Resistance vs Junction Temperature

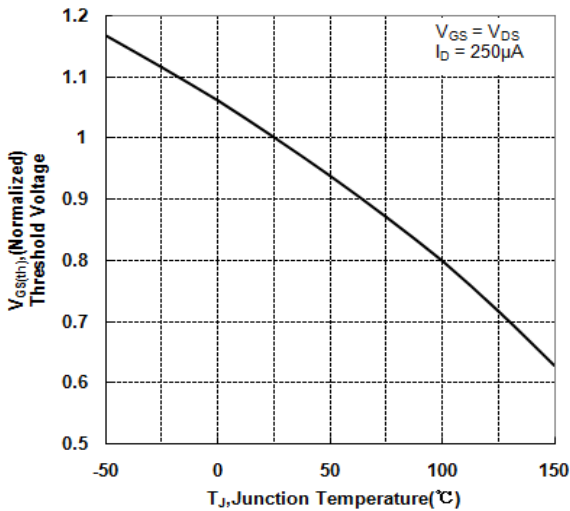

Figure 10. Normalized Threshold Voltage vs Junction Temperature

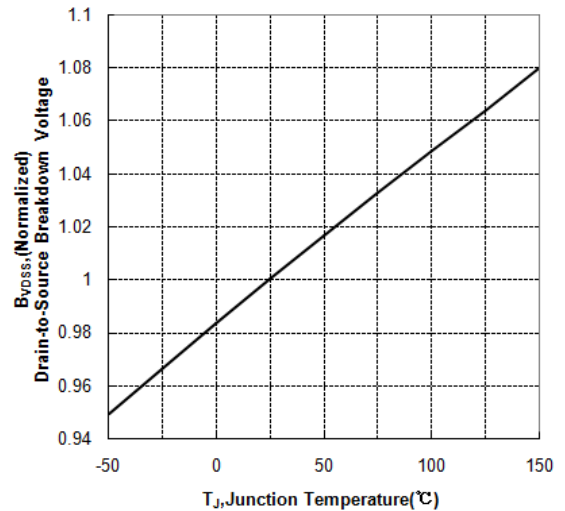

Figure 11. Normalized Breakdown Voltage vs Junction Temperature

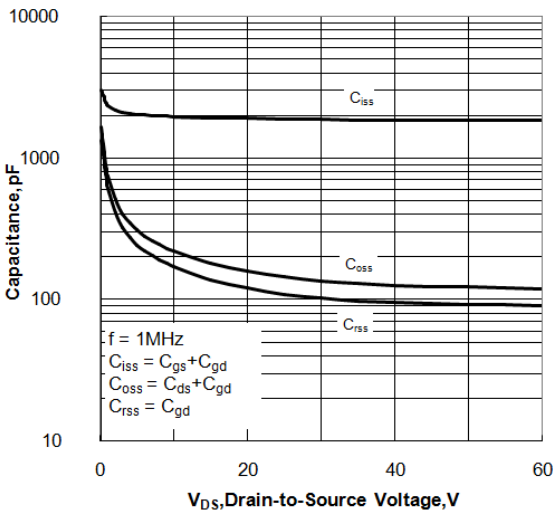

Figure 12. Capacitance Characteristics

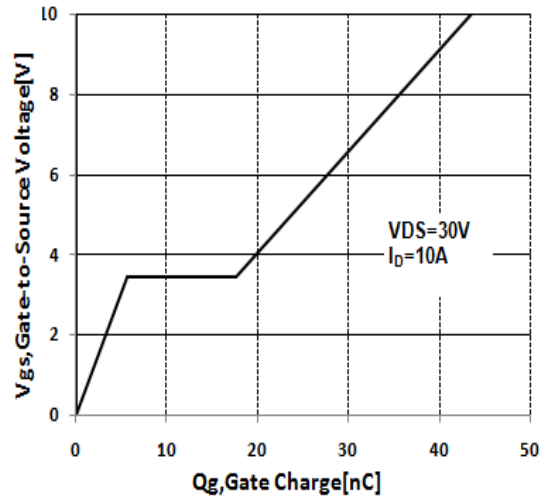

Figure 13. Typical Gate Charge vs Gate to Source Voltage

Test Circuit and Waveform



Figure 14. Gate Charge Test Circuit

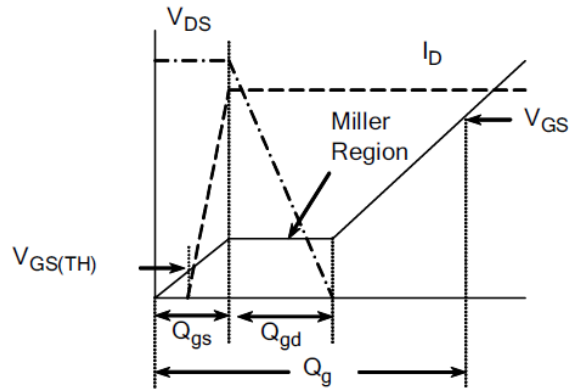

Figure 15. Gate Charge Waveforms



Figure 16. Resistive Switching Test Circuit

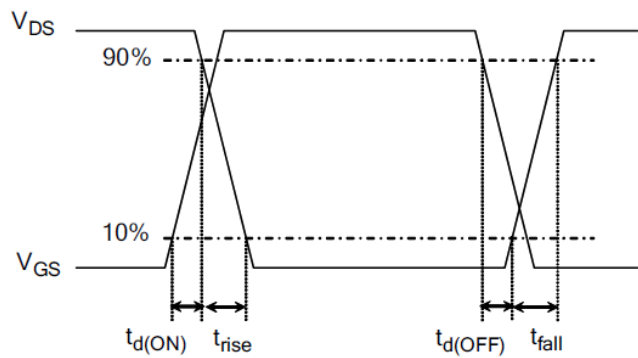

Figure 17. Resistive Switching Waveforms

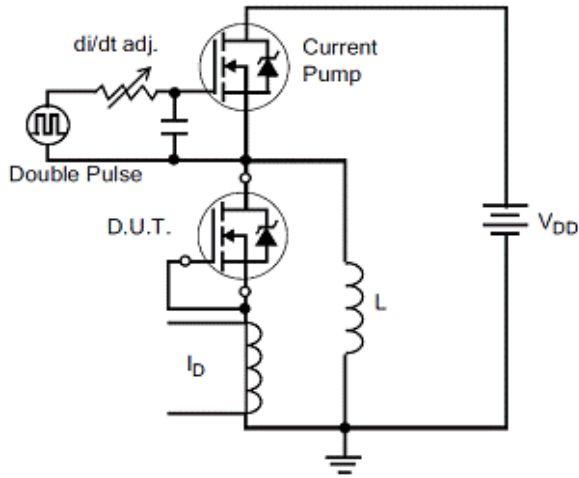

Figure 18. Diode Reverse Recovery Test Circuit

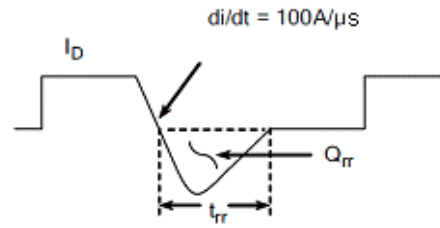

Figure 19. Diode Reverse Recovery Waveform

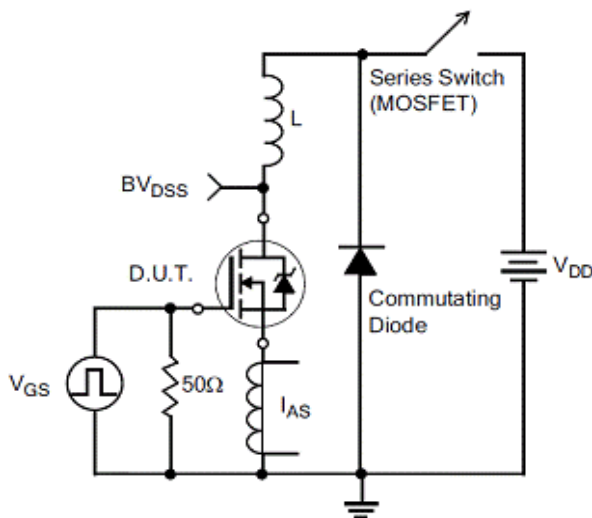

Figure 20. Unclamped Inductive Switching Test Circuit

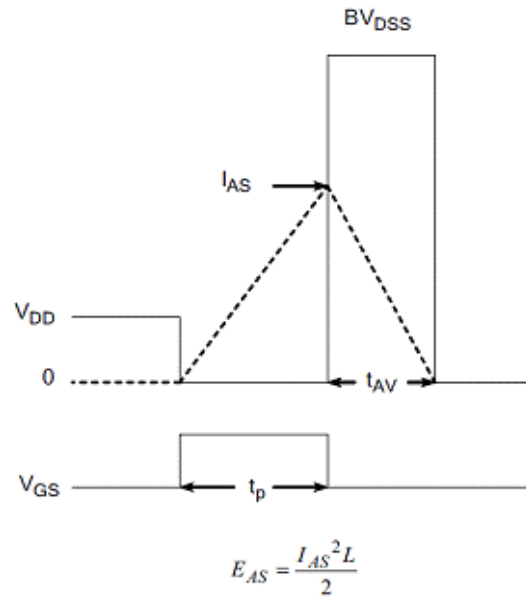
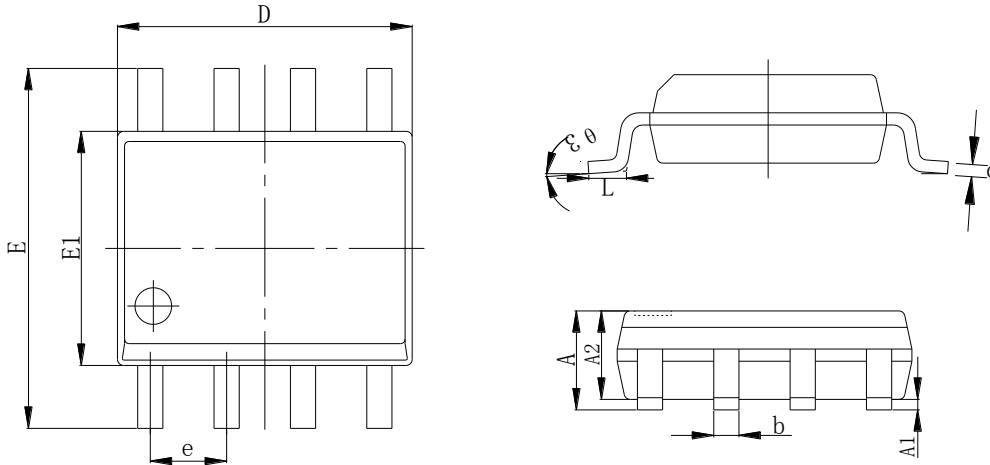

Figure 21. Unclamped Inductive Switching Waveform

Package Information:



Items	Values(mm)	
	MIN	MAX
A	1.30	1.80
A1	0.10	0.25
A2	1.30	1.50
E	5.80	6.20
E1	3.80	4.00
D	4.80	5.00
L	0.40	0.90
e	1.27TYP	
b	0.37	0.47
c	0.20 TYP	
θ3	0°	8°

SOP8 Package

