

N-Channel Trench Power MOSFET

General Description

The CS150N95 is N-channel MOS Field Effect Transistor designed for high current switching applications. Rugged E_{AS} capability and ultra low $R_{DS(ON)}$ is suitable for PWM, load switching especially for E-Bike controller applications.

Features

- $V_{DS}=150V$; $I_D=104A@V_{GS}=10V$;
 $R_{DS(ON)}<14.0m\Omega @V_{GS}=10V$
- Special Designed for E-Bike Controller Application
- Ultra Low On-Resistance
- High UIS and UIS 100% Test

Application

- 96V E-Bike controller applications
- Hard Switched and High Frequency Circuits
- Uninterruptible Power Supply

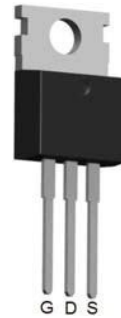

To-220 Top View

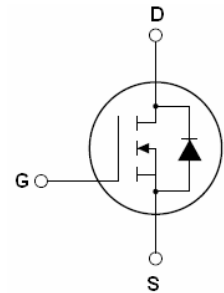

Schematic Diagram

$$V_{DS} = 150V$$

$$I_D = 104A$$

$$R_{DS(ON)} = 9.3m\Omega$$

Package Marking and Ordering Information

Device Marking	Device	Device Package	Reel Size	Tape width	Quantity
CS150N95	CS150N95	TO-220	-	-	-

Table 1. Absolute Maximum Ratings ($T_A=25^\circ C$)

Symbol	Parameter	Value	Unit
V_{DS}	Drain-Source Voltage ($V_{GS}=0V$)	150	V
V_{GS}	Gate-Source Voltage ($V_{DS}=0V$)	± 25	V
$I_{D(DC)}$	Drain Current (DC) at $T_c=25^\circ C$	104	A
$I_{D(DC)}$	Drain Current (DC) at $T_c=100^\circ C$	73	A
$I_{DM(pluse)}$	Drain Current-Continuous@ Current-Pulsed (Note 1)	416	A
dv/dt	Peak Diode Recovery Voltage	7	V/ns
P_D	Maximum Power Dissipation($T_c=25^\circ C$)	348	W
	Derating Factor	2.33	W/ $^\circ C$
E_{AS}	Single Pulse Avalanche Energy (Note 2)	1600	mJ
T_J, T_{STG}	Operating Junction and Storage Temperature Range	-55 To 175	$^\circ C$

Notes 1.Repetitive Rating: Pulse width limited by maximum junction temperature

2.EAS condition: $T_J=25^\circ C, V_{DD}=50V, V_G=10V, R_G=25\Omega$

Table 2. Thermal Characteristic

Symbol	Parameter	Value	Max	Unit
R _{θJC}	Thermal Resistance, Junction-to-Case	---	0.43	°C/W

Table 3. Electrical Characteristics (TA=25°C unless otherwise noted)

Symbol	Parameter	Conditions	Min	Typ	Max	Unit
On/Off States						
BV _{DSS}	Drain-Source Breakdown Voltage	V _{GS} =0V I _D =250μA	150			V
I _{DSS}	Zero Gate Voltage Drain Current(Tc=25°C)	V _{DS} =150V, V _{GS} =0V			1	μA
I _{DSS}	Zero Gate Voltage Drain Current(Tc=125°C)	V _{DS} =150V, V _{GS} =0V			10	μA
I _{GSS}	Gate-Body Leakage Current	V _{GS} =±20V, V _{DS} =0V			±100	nA
V _{GS(th)}	Gate Threshold Voltage	V _{DS} =V _{GS} , I _D =250μA	3		5	V
R _{DS(ON)}	Drain-Source On-State Resistance	V _{GS} =10V, I _D =40A		9.3	14.0	mΩ
Dynamic Characteristics						
g _{FS}	Forward Transconductance	V _{DS} =10V, I _D =15A	20			S
C _{iss}	Input Capacitance	V _{DS} =25V, V _{GS} =0V f=1.0MHz		9152		PF
C _{oss}	Output Capacitance			944		PF
C _{rss}	Reverse Transfer Capacitance			133		PF
Q _g	Total Gate Charge	V _{DS} =50V, I _D =40A V _{GS} =10V		274		nC
Q _{gs}	Gate-Source Charge			56		nC
Q _{gd}	Gate-Drain Charge			113		nC
Switching Times						
t _{d(on)}	Turn-on Delay Time	V _{DD} =65V, I _D =40A, R _L =15Ω V _{GS} =10V, R _G =2.5Ω		40		nS
t _r	Turn-on Rise Time			72		nS
t _{d(off)}	Turn-Off Delay Time			103		nS
t _f	Turn-Off Fall Time			35		nS
Source-Drain Diode Characteristics						
I _{SD}	Source-Drain Current(Body Diode)			104		A
I _{SDM}	Pulsed Source-Drain Current(Body Diode)			416		A
V _{SD}	Forward On Voltage ^(Note 1)	T _J =25°C, I _{SD} =40A, V _{GS} =0V		0.85	0.99	V
t _{rr}	Reverse Recovery Time ^(Note 1)	T _J =25°C, I _F =40A di/dt=100A/μs		80		nS
Q _{rr}	Reverse Recovery Charge ^(Note 1)				200	
t _{on}	Forward Turn-on Time	Intrinsic turn-on time is negligible(turn-on is dominated by L _S +L _D)				

Notes 1. Pulse Test: Pulse Width ≤ 300μs, Duty Cycle ≤ 1.5%, R_G=25Ω, Starting T_J=25°C

Test Circuit

1) E_{AS} Test Circuits

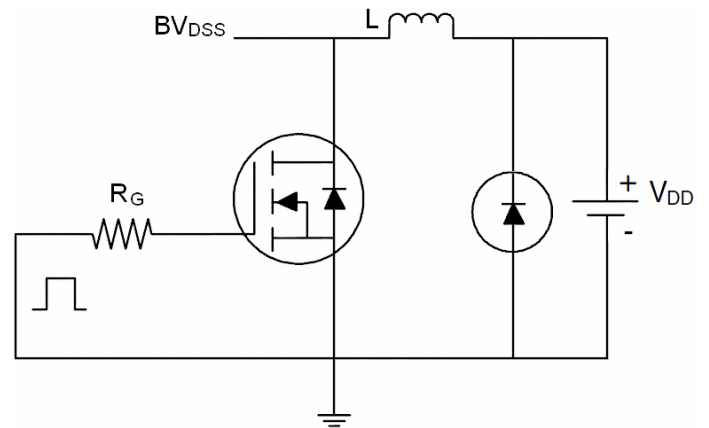
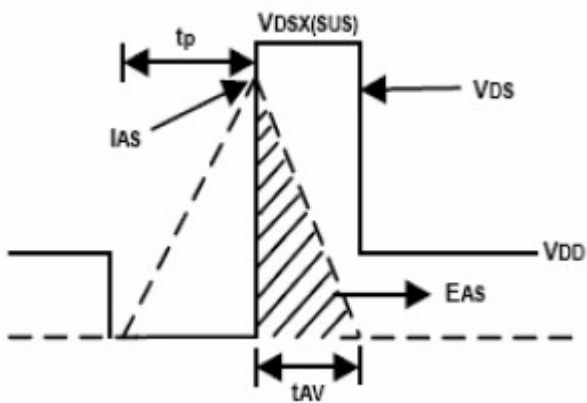

2) Gate Charge Test Circuit:

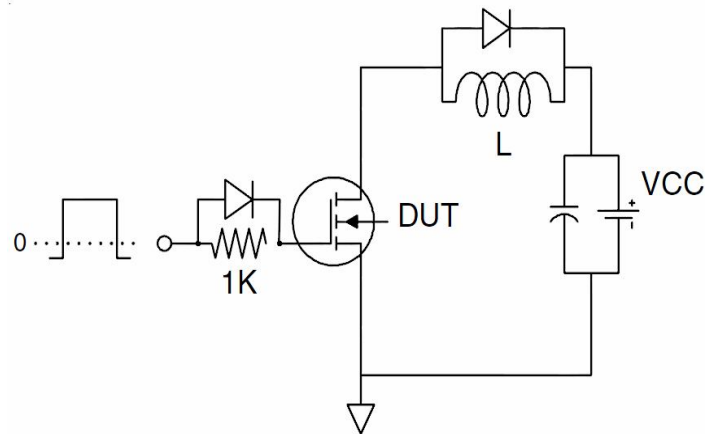
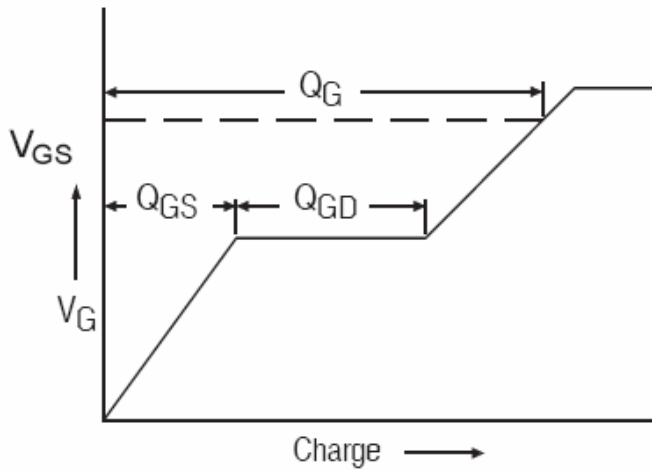

3) Switch Time Test Circuit:

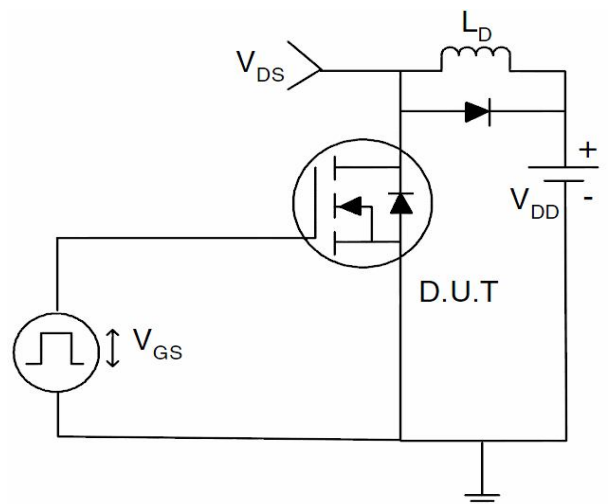
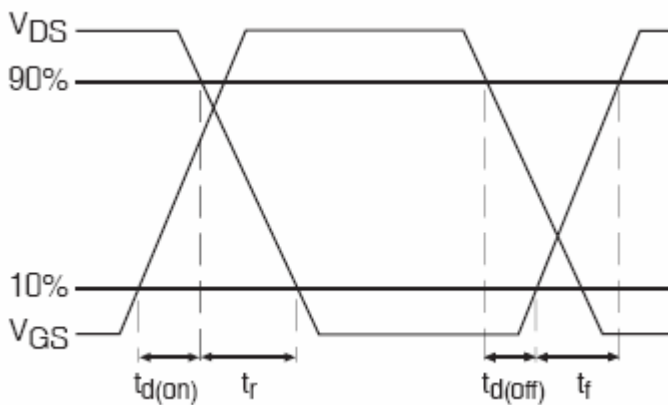

TYPICAL ELECTRICAL AND THERMAL CHARACTERISTICS (Curves)

Figure1. Output Characteristics

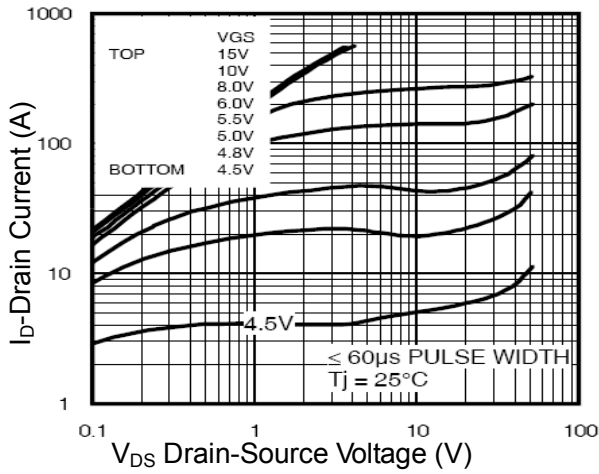

Figure2. Transfer Characteristics

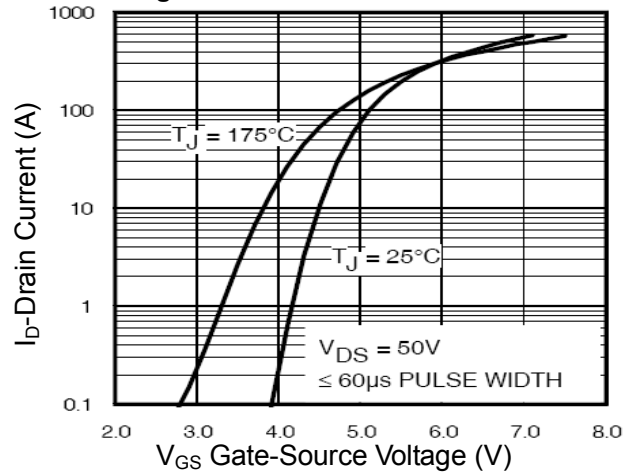

Figure3. BV_{DSS} vs Junction Temperature

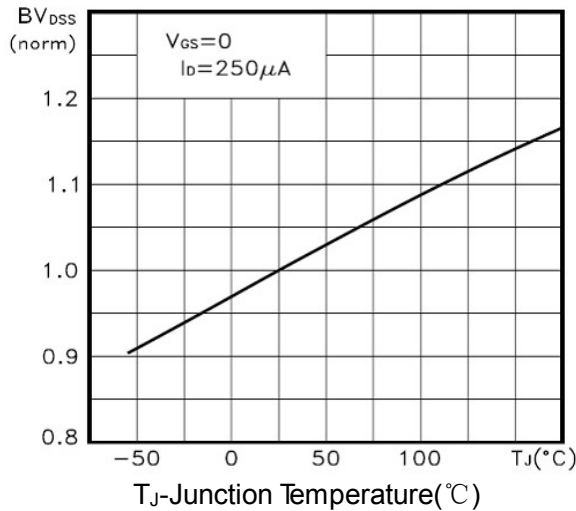

Figure4. I_D vs Junction Temperature

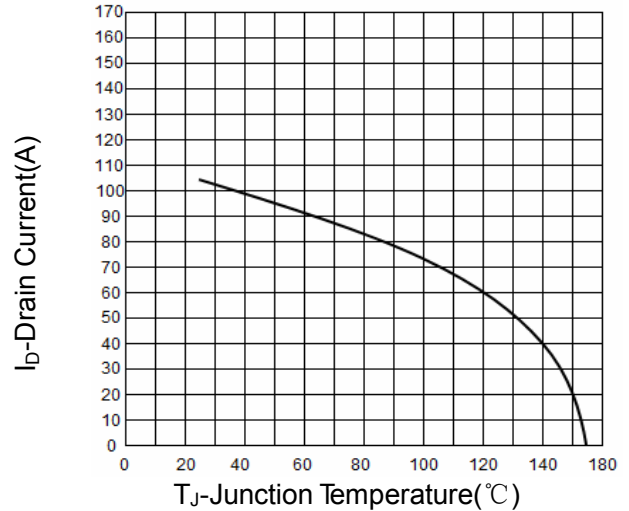

Figure5. V_{GS(th)} vs Junction Temperature

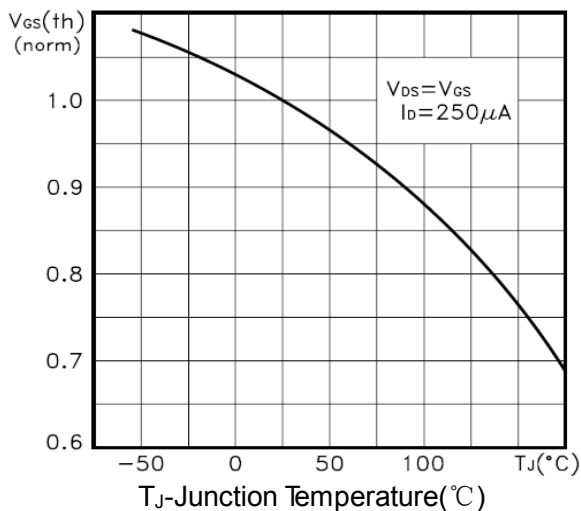

Figure6. R_{DS(on)} Vs Junction Temperature

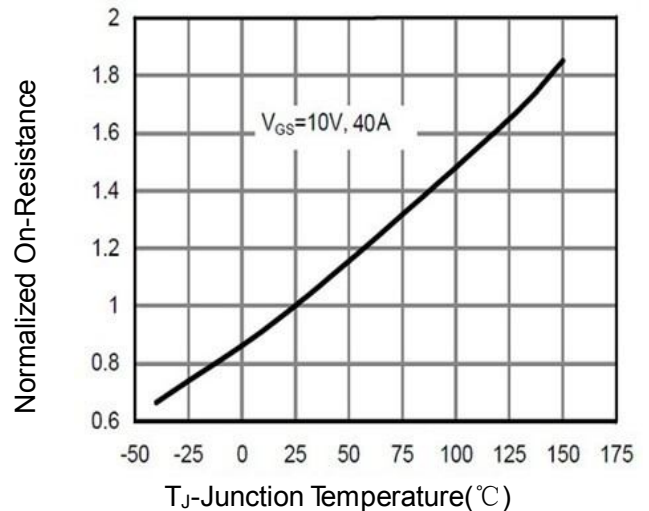

Figure7. Gate Charge

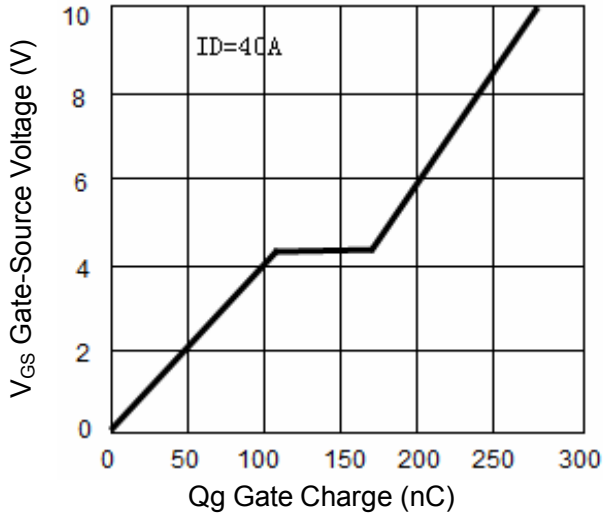

Figure8. Capacitance vs Vds

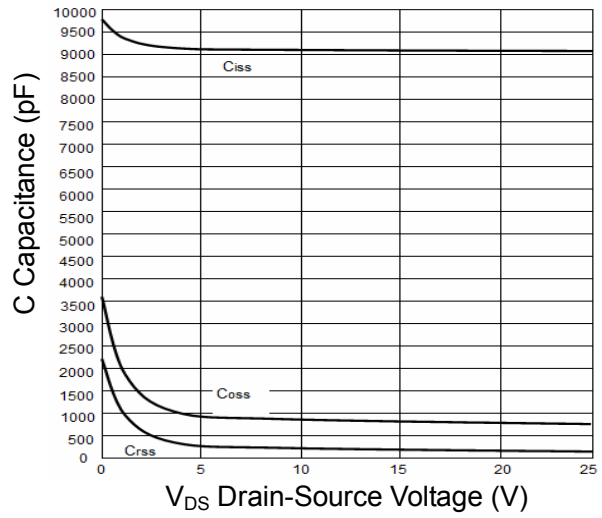

Figure9. Source- Drain Diode Forward

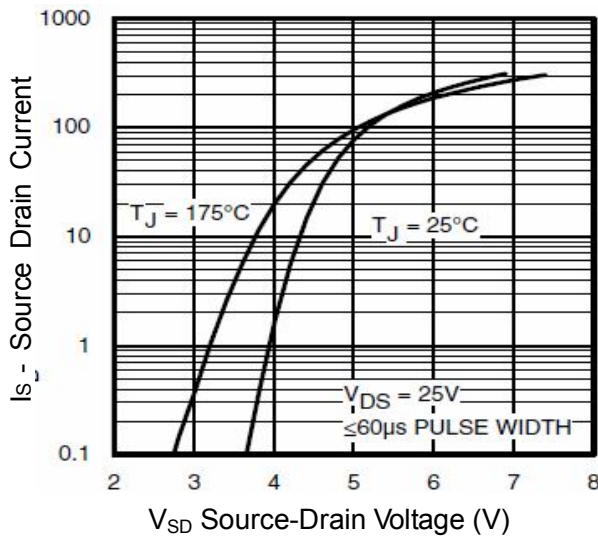

Figure10. Safe Operation Area

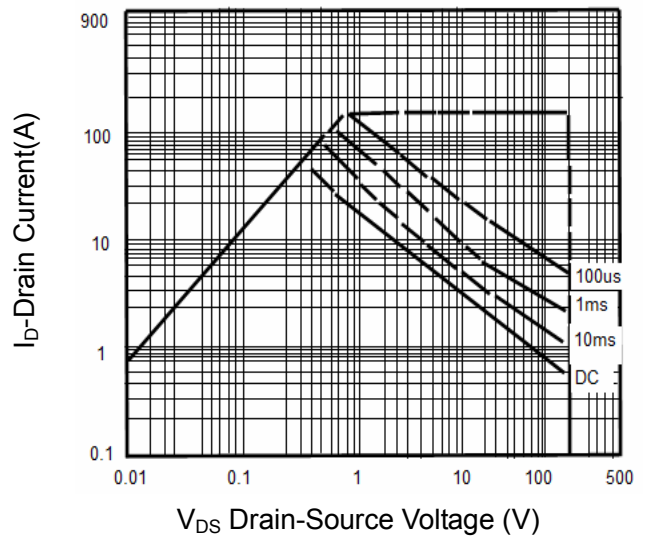

Figure11. Normalized Maximum Transient Thermal Impedance

