



CS15N04 AEP-G

General Description:

CS15N04 AEP-G, the silicon N-channel Enhanced VDMOSFETs, is obtained by advanced trench Technology which reduce the conduction loss, improve switching performance and enhance the avalanche energy. The transistor can be used in various power switching circuit for system miniaturization and higher efficiency. The package form is SOP-8, which accords with the RoHS standard. CS15N04AEP-G is halogen free.

Features:

- | **Fast Switching**
- | **Low ON Resistance ($R_{dson} \leq 13m\Omega$)**
- | **Low Reverse transfer capacitances(Typical:115pF)**
- | **100% Single Pulse avalanche energy Test**
- | **Halogen free**

V_{DSS}	40	V
I_D	15	A
$P_D(T_C=25^\circ C)$	3.1	W
$R_{DS(ON)Typ} (10V)$	8	m Ω

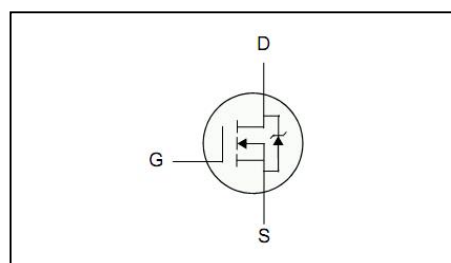
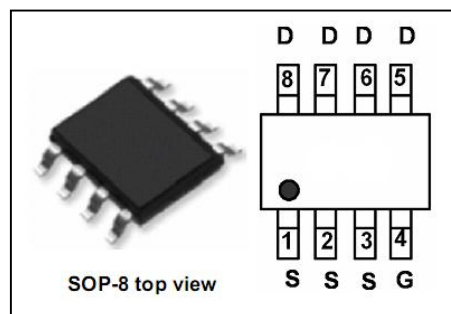

Applications:

Power switch circuit of adaptor and charger.

Absolute ($T_A=25^\circ C$ unless otherwise specified):

Symbol	Parameter	Rating	Units
V_{DSS}	Drain-to-Source Voltage	40	V
I_D	Continuous Drain Current	15	A
	Continuous Drain Current $T_A = 100^\circ C$	9	A
I_{DM}^{a1}	Pulsed Drain Current	60	A
V_{GS}	Gate-to-Source Voltage	± 20	V
E_{AS}^{a2}	Single Pulse Avalanche Energy	190	mJ
P_D	Power Dissipation	3.1	W
	Derating Factor above $25^\circ C$	0.025	W/ $^\circ C$
T_J, T_{stg}	Operating Junction and Storage Temperature Range	-55 to 150	$^\circ C$

OFF Characteristics						
Symbol	Parameter	Test Conditions	Rating			Units
			Min	Typ.	Max	
V_{DSS}	Drain to Source Breakdown Voltage	$V_{GS}=0V, I_D=250\mu A$	40	--	--	V
I_{DSS}	Drain to Source Leakage Current	$V_{DS} = 40V, V_{GS}=0V$	--	--	1	μA
$I_{GSS(F)}$	Gate to Source Forward Leakage	$V_{DS} = 0V, V_{GS} = 20V$	--	--	100	nA
$I_{GSS(R)}$	Gate to Source Reverse Leakage	$V_{DS} = 0V, V_{GS} = -20V$	--	--	-100	nA

ON Characteristics						
Symbol	Parameter	Test Conditions	Rating			Units
			Min.	Typ.	Max.	
$R_{DS(ON)}$	Drain-to-Source On-Resistance	$V_{GS}=10V, I_D=15A$	--	8	13	$m\Omega$
		$V_{GS}=4.5V, I_D=12A$	--	11	16	$m\Omega$
$V_{GS(TH)}$	Gate Threshold Voltage	$V_{DS} = V_{GS}, I_D = 250\mu A$	1.2	--	2.0	V

Pulse width $t_p \leq 300\mu s, \delta \leq 2\%$

Dynamic Characteristics						
Symbol	Parameter	Test Conditions	Rating			Units
			Min.	Typ.	Max.	
C_{iss}	Input Capacitance	$V_{GS} = 0V, V_{DS} = 20V$ $f = 1.0MHz$	--	1920	--	pF
C_{oss}	Output Capacitance		--	150	--	
C_{rss}	Reverse Transfer Capacitance		--	115	--	

Resistive Switching Characteristics						
Symbol	Parameter	Test Conditions	Rating			Units
			Min.	Typ.	Max.	
$t_{d(ON)}$	Turn-on Delay Time	$I_D = 15A, V_{DD} = 20V$ $V_{GS} = 10V, R_G = 10\Omega$	--	13.1	--	ns
t_r	Rise Time		--	16.8	--	
$t_{d(OFF)}$	Turn-Off Delay Time		--	62.4	--	
t_f	Fall Time		--	22.9	--	
Q_g	Total Gate Charge	$I_D = 15A, V_{DD} = 32V$ $V_{GS} = 10V$	--	34.9	--	nC
Q_{gs}	Gate to Source Charge		--	4.7	--	
Q_{gd}	Gate to Drain ("Miller") Charge		--	8.8	--	

Source-Drain Diode Characteristics						
Symbol	Parameter	Test Conditions	Rating			Units
			Min.	Typ.	Max.	
I_S	Continuous Source Current (Body Diode)		--	--	15	A
I_{SM}	Maximum Pulsed Current (Body Diode)		--	--	60	A
V_{SD}	Diode Forward Voltage	$V_{GS}=0V, I_S=15A$	--	--	1.2	V
t_{rr}	Reverse Recovery Time	$I_S=15A, V_{GS}=0V$	--	14.7	--	ns
Q_{rr}	Reverse Recovery Charge	$dI_F/dt=100A/us$	--	8.9	--	nC
Pulse width $t_p \leq 300\mu s, \delta \leq 2\%$						

Symbol	Parameter	Max.	Units
$R_{\theta JA}$	Junction-to-Ambient	40	$^{\circ}C/W$

- a1: Repetitive rating; pulse width limited by maximum junction temperature
- a2: $L=1mH, I_{as}=19.5A, R_g=25\ \Omega, V_{dd}=30V, \text{Start } T_J=25^{\circ}C$
- a3: Recommend soldering temperature defined by IPC/JEDEC J-STD 020

Characteristics Curve:

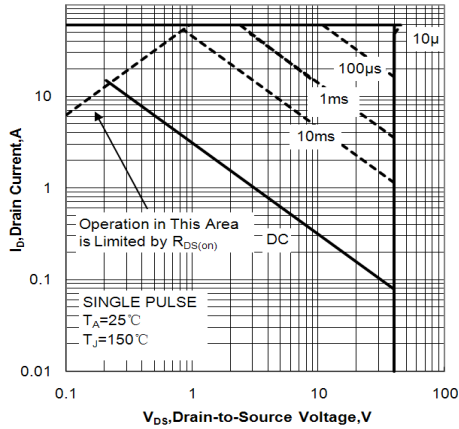

Figure 1. Maximum Safe Operating Area

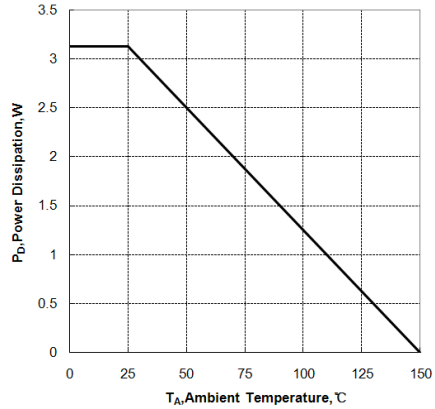

Figure 2. Maximum Power Dissipation vs Ambient Temperature

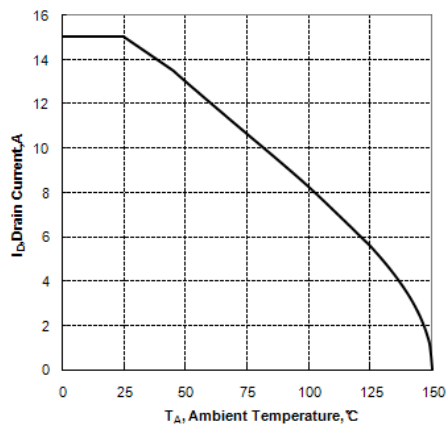

Figure 3. Maximum Continuous Drain Current vs Ambient Temperature

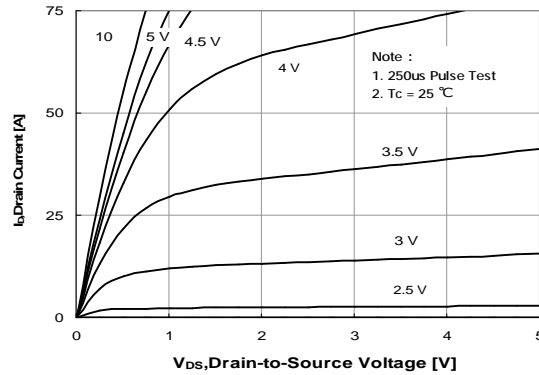

Figure 4. Typical Output Characteristics

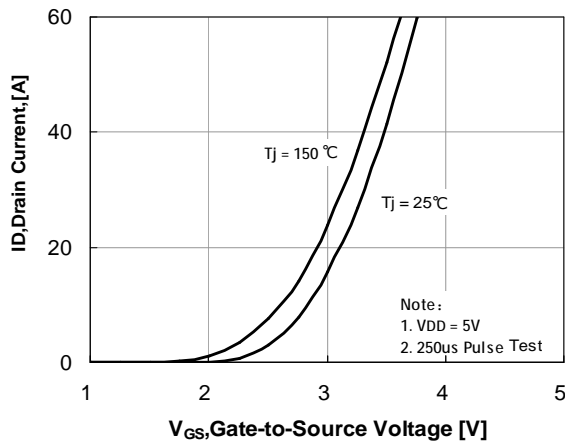

Figure 5. Typical Transfer Characteristics

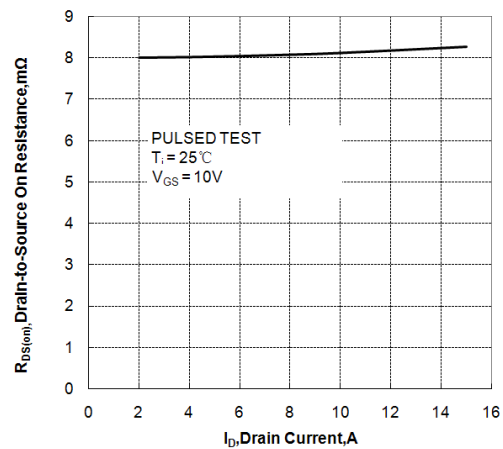

Figure 6. Drain-to-Source On Resistance vs Drain Current

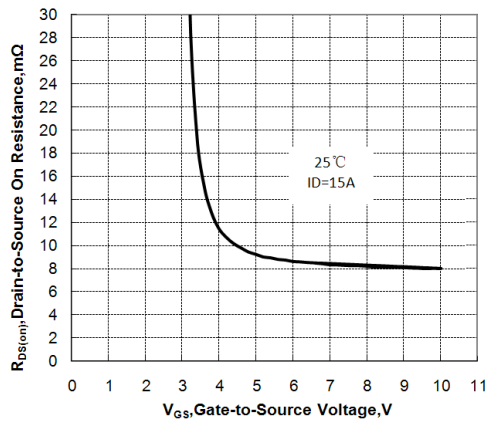

Figure 7. Drain-to-Source On Resistance vs Gate Voltage

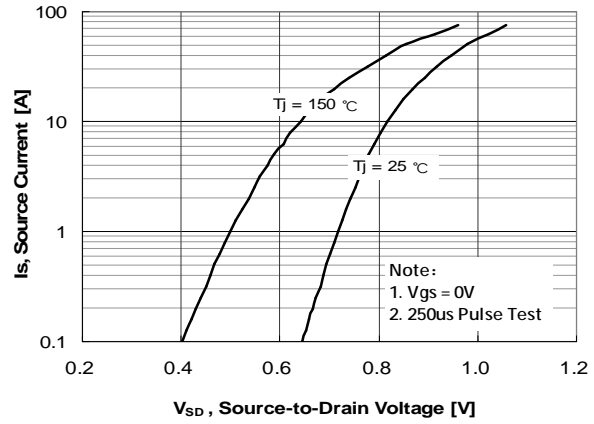

Figure 8. Body Diode Forward Voltage vs Source Current

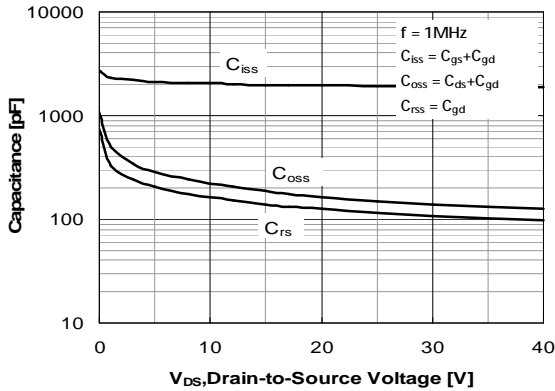

Figure 9. Typical Capacitance vs Drain to Source Voltage

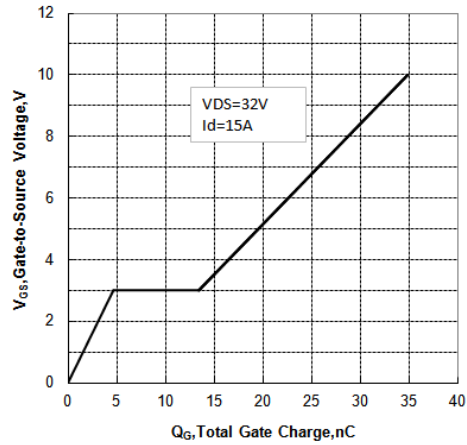

Figure 10. Gate Charge Characteristics

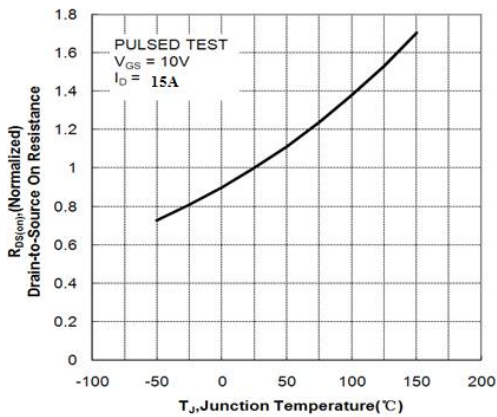

Figure 11. Typical Drain to Source on Resistance vs Junction Temperature

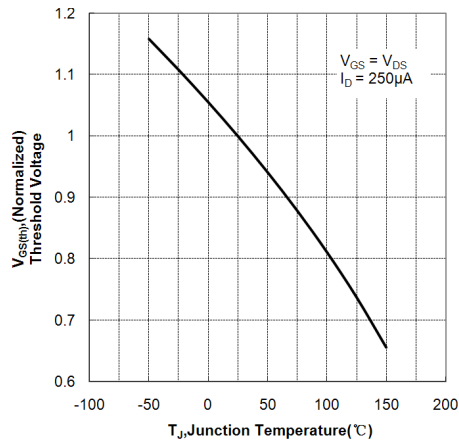

Figure 12. Typical Threshold Voltage vs Junction Temperature

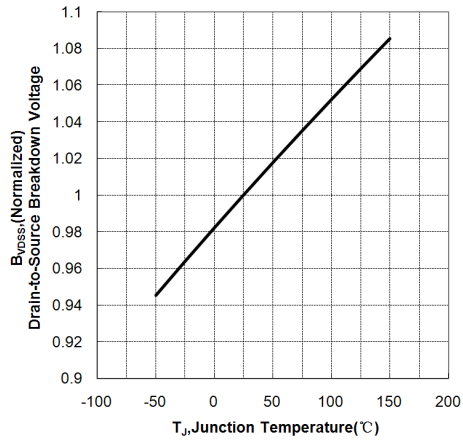

Figure 13 .Typical Breakdown Voltage vs Junction Temperature

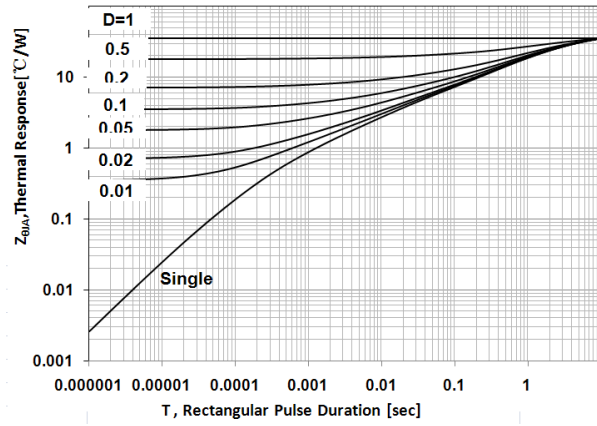

Figure 14 .Maximum Effective Transient Thermal Impedance

Test Circuit and Waveform



Figure 17. Gate Charge Test Circuit



Figure 18. Gate Charge Waveform



Figure 19. Resistive Switching Test Circuit



Figure 20. Resistive Switching Waveforms



Figure 21. Diode Reverse Recovery Test Circuit



Figure 22. Diode Reverse Recovery Waveform

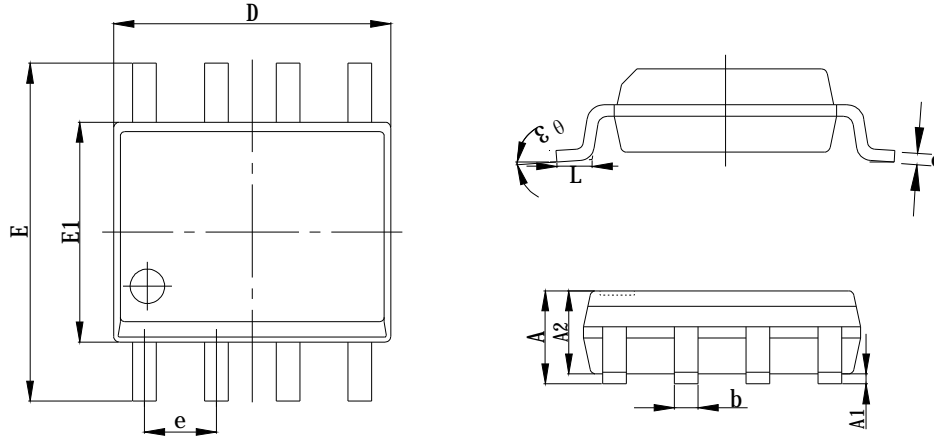

Figure 23. Unclamped Inductive Switching Test Circuit



Figure 24. Unclamped Inductive Switching Waveforms

Package Information



Items	Values(mm)	
	MIN	MAX
A	1.30	1.80
A1	0.10	0.25
A2	1.30	1.50
E	5.80	6.20
E1	3.80	4.00
D	4.80	5.00
L	0.40	0.90
e	1.27 TYP	
b	0.37	0.47
c	0.20 TYP	
θ	0°	8°

SOP-8Package

The name and content of poisonous and harmful material in products

Part's Name	Hazardous Substance									
	Pb	Hg	Cd	Cr(VI)	PBB	PBDE	DIBP	DEHP	DBP	BBP
Limit	≤ 0.1%	≤ 0.1%	≤ 0.01%	≤0.1%	≤0.1%	≤0.1%	≤0.1%	≤0.1%	≤0.1%	≤0.1%
Lead Frame	○	○	○	○	○	○	○	○	○	○
Molding	○	○	○	○	○	○	○	○	○	○
Chip	○	○	○	○	○	○	○	○	○	○
Wire Bonding	○	○	○	○	○	○	○	○	○	○
Solder	×	○	○	○	○	○	○	○	○	○
Note	○: Means the hazardous material is under the criterion of 2011/65/EU. ×: Means the hazardous material exceeds the criterion of 2011/65/EU. The plumbum element of solder exist in products presently, but within the allowed range of Eurogroup's RoHS.									

Warnings

1. Exceeding the maximum ratings of the device in performance may cause damage to the device, even the permanent failure, which may affect the dependability of the machine. It is suggested to be used under 80 percent of the maximum ratings of the device.
2. When installing the heat sink, please pay attention to the torsional moment and the smoothness of the heat sink.
3. VDMOSFETs is the device which is sensitive to the static electricity, it is necessary to protect the device from being damaged by the static electricity when using it.
4. This publication is made by Huajing Microelectronics and subject to regular change without notice.

WUXI CHINA RESOURCES HUAJING MICROELECTRONICS CO., LTD.

Add: No.14 Liangxi RD. Wuxi, Jiangsu, China Mail:214061 <http://www.crhj.com.cn>
Tel: +86 0510-85807228 Fax: +86- 0510-85800864

Marketing Part: Post: 214061 Tel: +86 0510-81805277/81805336
Fax: +86 0510-85800360/85803016

Application and Service: Post: 214061 Tel / Fax: +86- 0510-81805243/81805110