

www.angerei.com TEL:18520874087 QQ:1659747718

CS201

Audio Player Microcontroller

Versions: 0.0.1
2021.06.03



Revision History

www.angerei.com TEL:18520874087 QQ:1659747718

Date	Version	Comments	Revised by
2021-06-03	0.0.1	First draft	Leo

Table of Contents

TABLE OF CONTENTS	2
1 PRODUCT FEATURES	3
2 PACKAGE DEFINITION	4
2.1 PIN ASSIGNMENT	4
2.2 PIN DESCRIPTIONS	4
3 CHARACTERISTICS	7
3.1 PMU PARAMETERS	7
3.2 IO PARAMETERS	7
3.3 AUDIO DAC PARAMETERS	7
3.4 AUDIO ADC PARAMETERS	8
3.5 CURRENT PARAMETERS	8
4 PACKAGE INFORMATION	9

1 Product Features

CPU and Flexible IO

- 32bit High performance CPU with DSP instruction
- Program memory: internal 2M bit flash
- Flexible GPIO pins with Programmable pull-up and pull-down resistors;
- Support GPIO wakeup or interrupt;

Audio Interface

- High performance stereo DAC with 95dB SNR;
- Three channel high performance ADC with 90dB SNR;
- Stereo MIC amplifier input;
- Support flexible audio EQ adjust;
- Support Sample rate 8, 11.025, 12, 16, 22.05, 32, 44.1 and 48KHz;
- Four channel Stereo Analog MUX;
- VID and PID information can be configured;
- Audio head insertion and extraction detection;
- Earphone microphone detection;
- Automatic recognition of OMTP and CTIA headphones, and automatic adaptation;

Peripheral and Interfaces

- Support Touch Key;
- Two 32-bit timers;
- Two multi-function 32-bit timers, support Capture and PWM mode;
- WatchDog;
- Three full-duplex UART;
- Two SPI;
- IR controller;
- Integrate IRTC;
- SD Card Host controller;
- Sixteen Channels 10-bit SARADC;
- Build in PMU, such as LDO/LVD/POR;

Package

- QFN20 3x3

Temperature

- Operating temperature: -40°C to +85°C;
- Storage temperature: -65°C to +150°C;

2.1 Pin Assignment

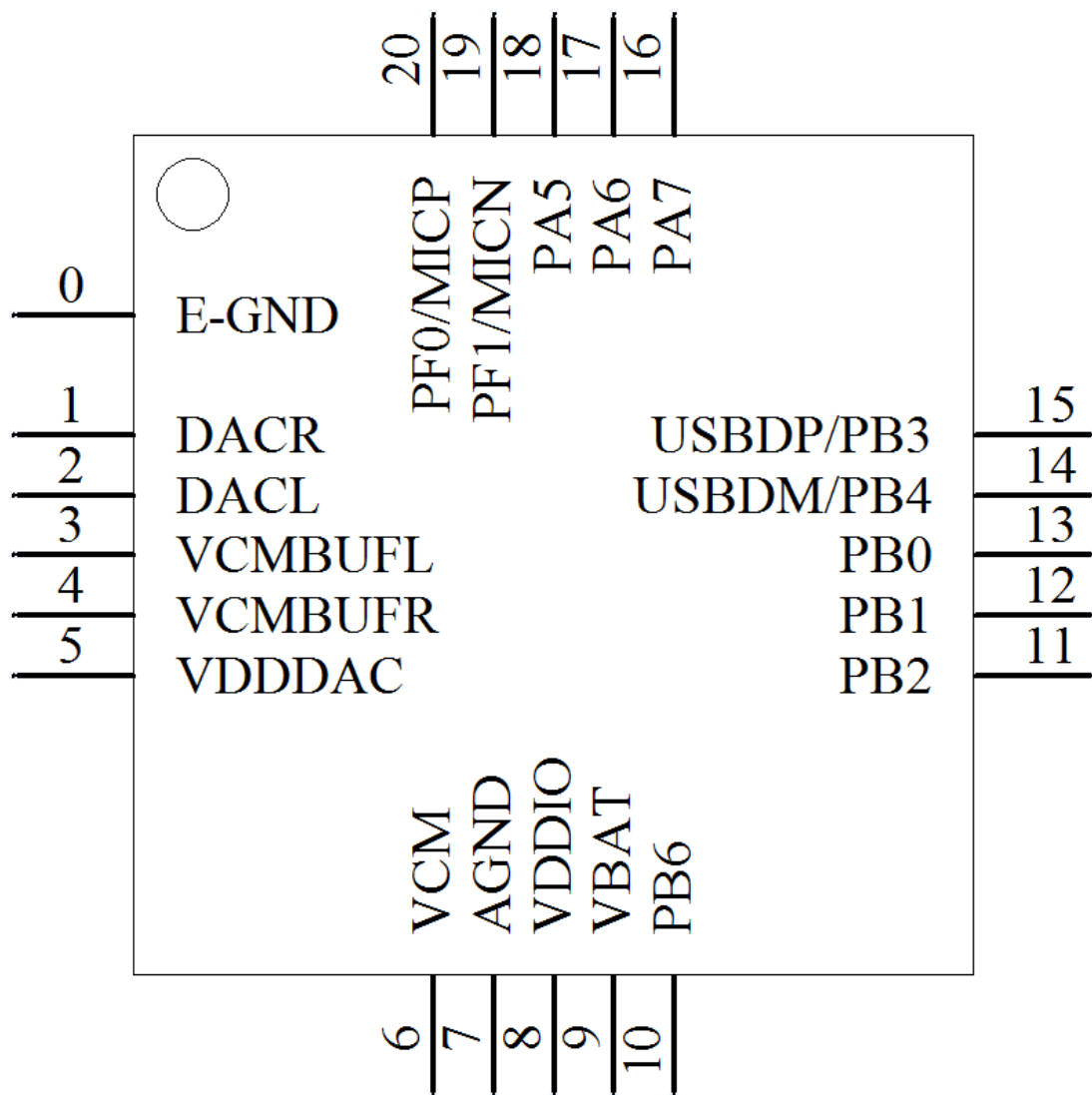

2.2 Pin Descriptions

Table 2-1 QFN20 3x3 pin description

Pin No.	Name	Type	Function
0	E-GND	GND	E-Pad Ground
1	DACR	A	DAC R
2	DACL	A	DAC L

3	VCMBUFL	A	VCM buffer left output
4	VCMBUFR	A	VCM buffer right output
5	VDDDAC	PWR	DAC power
6	VCM	PWR	DAC VCM
7	AGND	GND	DAC Ground
8	VDDIO	PWR	VDDIO power output
9	VBAT	PWR	VBAT power input
10	PB6	I/O	ADC3 AUXR3 SPI1DO -G4 TX0-G5 FMOSC-G8 PWM1-T2-G3 TMR2CAP_G6/IR_G6 PB6
11	PB2	I/O	ADC2 AUXR2 SDDAT0-G1 SPI1DO-G1 SPI1DI-G4 TX0-G3 TX1-G2 HSTRX-G6 PWM2-T3-G2 TMR2CAP_G4/IR_G4 IISDO-G2 PB2
12	PB1	I/O	ADC1 AUXL2 SDCLK-G1/G2/G3/G4 SPI0DI-G3 SPI1CLK-G1 SPI1CLK-G2 RX0-G3 RX1-G2 HSTRX-G5 FMOSC-G6 PWM1-T3-G2 IISCLK-G2 PB1
13	PB0	I/O	SDCMD-G1/G2/G3 SPI1DI-G1 SPI1DI-G2 FMOSC-G5 PWM0-T3-G2 IISLRCLK-G2 PB0
14	USBDM/PB4	I/O	USBDM SDDAT0-G2 SDDAT0-G4 SPI0CLK-G3 SPI1DO-G2 RX0-G4 HSTRX-G8 PWM1-T3-G3 TMR1CAP PB4
15	USBDP/PB3	I/O	USBDP SDDAT0-G3 SDCMD-G4

			SPI0DO-G3 TX0-G4 HSTRX-G7 PWM0-T3-G3 TMR0CAP PB3
16	PA7	I/O	ADC0 AUXR1 SDDAT0-G5 SPI1DO SPI1DATA-G3 TX0-G2 HSTRX-G4 FMOSC-G4 PWM1-T2-G2 TMR2CAP_G3/IR_G3 IISMCLK-G2 PA7
17	PA6	I/O	AUXL1 SDCLK-G5 SPI1CLK-G3 RX0-G2 HSTRX-G3 FMOSC-G3 PWM0-T2-G2 PA6
18	PA5	I/O	SDCMD-G5 SPI1DI-G3 PWM2-T3-G1 PA5
19	PF1/MICN	I/O	MICN PWM2-T3-G3 PF1
20	PF0/MICP	I/O	MICP ADC4 TX0-G7 PWM2-T2-G2 TMR3CAP_G1/IR_G8 PF0

Note: I/O: Digital input/output; I : Digital input; A : Analog Pin; PWR: Power Pin; GND: Ground.

3 Characteristics

www.angerei.com TEL:18520874087 QQ:1659747718

3.1 PMU Parameters

Table 3-1 PMU voltage input Parameters

Sym	Characteristics	Min	Typ	Max	Unit	Conditions
VBAT	Voltage input	3.0	3.7	5.0	V	

Table 3-2 3.3V LDO Parameters

Sym	Characteristics	Min	Typ	Max	Unit	Conditions
VDDIO	3.3V LDO voltage output	-	3.3	-	V	Light Loading condition
Δ VVDDIO	Output Mismatch 1-sigma	-	56	-	mV	VDDIO=3.3v
ILOAD	Maximum output current	-	-	150	mA	@VBAT=3.6v
ISC	Short Circuit Current Limit	-	-	300	mA	@VBAT=3.8v

3.2 IO Parameters

Table 3-3 I/O Parameters

GPIO—Electrical Characteristics							
Symbol	Description	Related GPIO	Min	Typical	Max	Units	Conditions
V _{IL}	Low-level input voltage		-0.3		1.27	V	VDDIO=3.3V
V _{IH}	High-level input voltage		2.03		3.6	V	VDDIO=3.3V
Driver Ability 1	Output Driver Ability 1			32		mA	VDDIO=3.3V
Driver Ability 0	Output Driver Ability 0			8		mA	VDDIO=3.3V
R _{PUP0}	Internal pull-up resistor 0		8	10	12	K Ω	
R _{PUP1}	Internal pull-up resistor 1		0.24	0.3	0.36	K Ω	
R _{PUP2}	Internal pull-up resistor 2		160	200	240	K Ω	
R _{PDN0}	Internal pull-down resistor 0		8	10	12	K Ω	
R _{PDN1}	Internal pull-down resistor 1		0.24	0.3	0.36	K Ω	
R _{PDN2}	Internal pull-down resistor 2		160	200	240	K Ω	

3.3 Audio DAC Parameters

Table 3-4 Audio DAC Parameters

Sym	Characteristics	Min	Typ	Max	Unit	Conditions
SNR		-	95	-	dB	VCM cap=NC VDDDAC cap=1uF with A-wt filter Output -3dBV Fin=1KHz
THD+N		-	-70	-	dB	VCM cap=NC VDDDAC cap=1uF with A-wt filter Output -3dBV with 10K loading Fin=1KHz

Sym	Characteristics	Min	Typ	Max	Unit	Conditions
Output Range	Maximum output voltage	-	2.6		V _{peak-peak}	32ohm Loading

3.4 Audio ADC Parameters

Table 3-5 Audio ADC Parameters

Sym	Characteristics	Min	Typ	Max	Unit	Conditions
SNR		-	90	-	dB	VCM cap=NC VDDDAC cap=1uF with A-wt filter Input sine amplitude, 850mV RMS Fin=1KHz
THD+N		-	-80	-	dB	VCM cap=NC VDDDAC cap=1uF with A-wt filter Input sine amplitude, 850mV RMS Fin=1KHz.
Input Range	Input sine wave peak amplitude	0		VCM	V	From aux input, aux 0db gain, VCM represent VCM voltage.

3.5 Current Parameters

Table 3-6 Current Parameters

Sym	Characteristics	Min	Typ	Max	Unit	Conditions
IRTC	RTC mode current	-	4	-	uA	4.2V input, room temp.
Sleep	Sleep current	-	500	2000	uA	3.3V input, room temp

4 Package Information

www.angerei.com TEL:18520874087 QQ:1659747718

QFN20 3x3

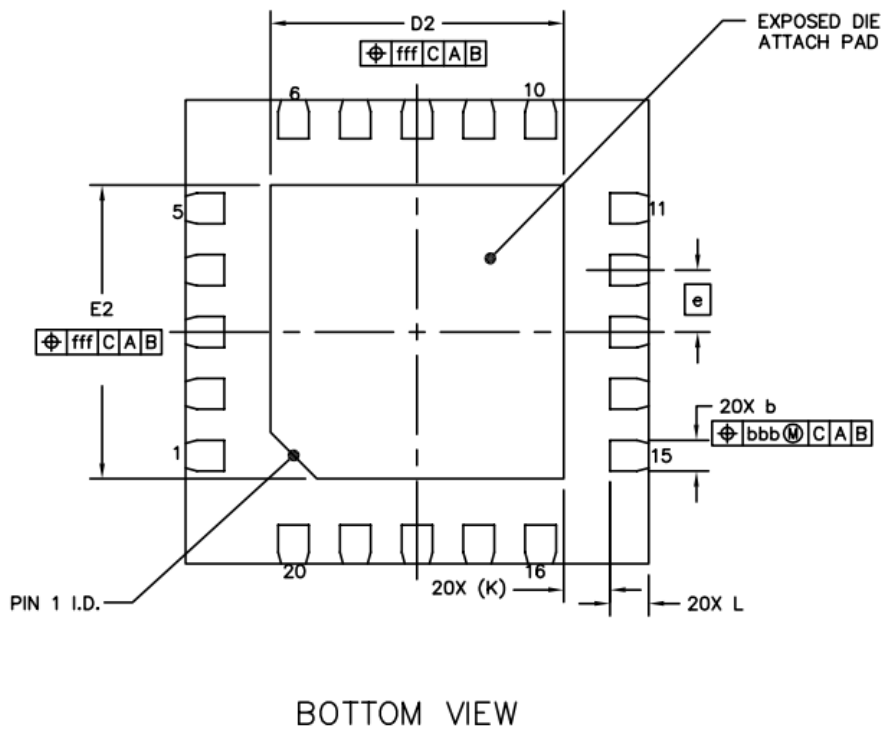
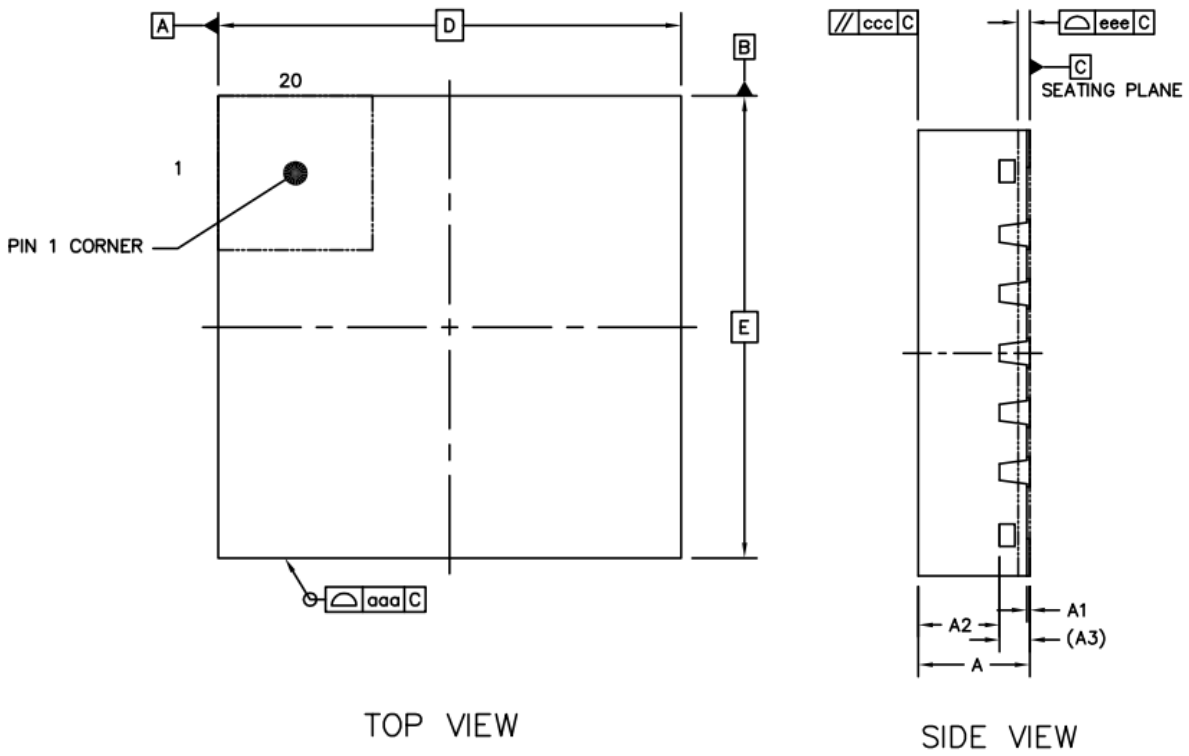

		SYMBOL	MIN	NOM	MAX
TOTAL THICKNESS		A	0.7	0.75	0.8
STAND OFF		A1	0	0.02	0.05
MOLD THICKNESS		A2	---	0.55	---
L/F THICKNESS		A3	0.203 REF		
LEAD WIDTH		b	0.15	0.2	0.25
BODY SIZE	X	D	3 BSC		
	Y	E	3 BSC		
LEAD PITCH		e	0.4 BSC		
EP SIZE	X	D2	1.8	1.9	2
	Y	E2	1.8	1.9	2
LEAD LENGTH		L	0.15	0.25	0.35
LEAD TIP TO EXPOSED PAD EDGE		K	0.3 REF		
PACKAGE EDGE TOLERANCE		aaa	0.1		
MOLD FLATNESS		ccc	0.1		
COPLANARITY		eee	0.08		
LEAD OFFSET		bbb	0.07		
EXPOSED PAD OFFSET		fff	0.1		