

P-Channel Trench Power MOSFET

General Description

The CS2301 uses advanced trench technology to provide excellent $R_{DS(ON)}$, low gate charge and operation with gate voltages as low as -2.5V. This device is suitable for use as a battery protection or in other switching application.

Features

- $V_{DS} = -20V, I_D = -3A$
 $R_{DS(ON)} < 90m\Omega @ V_{GS} = -4.5V$
 $R_{DS(ON)} < 120m\Omega @ V_{GS} = -2.5V$
- High Power and current handling capability
- Lead free product is acquired
- Surface Mount Package

Application

- Battery protection
- Load switch
- Power management

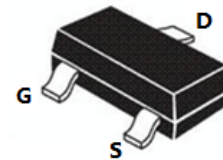
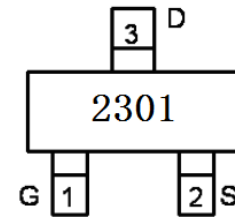
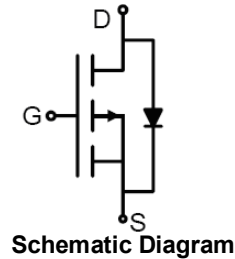

Package Marking and Ordering Information

Device Marking	Device	Device Package	Reel Size	Tape width	Quantity
2301	CS2301	SOT-23	Ø180mm	8mm	3000 units

Table 1. Absolute Maximum Ratings ($T_A=25^\circ C$)

Symbol	Parameter	Value	Unit
V_{DS}	Drain-Source Voltage ($V_{GS}=0V$)	-20	V
V_{GS}	Gate-Source Voltage ($V_{DS}=0V$)	± 12	V
I_D	Drain Current-Continuous	-3	A
$I_{DM (pluse)}$	Drain Current-Continuous@ Current-Pulsed (Note 1)	-10	A
P_D	Maximum Power Dissipation	1	W
T_J, T_{STG}	Operating Junction and Storage Temperature Range	-55 To 150	$^\circ C$

Notes 1.Repetitive Rating: Pulse width limited by maximum junction temperature

Table 2. Thermal Characteristic

Symbol	Parameter	Value	Unit
$R_{\theta JA}$	Thermal Resistance, Junction-to-Ambient	125	$^\circ C/W$

Table 3. Electrical Characteristics (T_A=25°C unless otherwise noted)

Symbol	Parameter	Conditions	Min	Typ	Max	Unit
On/Off States						
B _V DSS	Drain-Source Breakdown Voltage	V _{GS} =0V I _D =-250μA	-20	-24		V
I _{DSS}	Zero Gate Voltage Drain Current	V _{DS} =-20V, V _{GS} =0V			-1	μA
I _{GSS}	Gate-Body Leakage Current	V _{GS} =±12V, V _{DS} =0V			±100	nA
V _{GS(th)}	Gate Threshold Voltage	V _{DS} =V _{GS} , I _D =-250μA	-0.4	-0.7	-1	V
g _{FS}	Forward Transconductance	V _{DS} =-5V, I _D =-2A		8		S
R _{DS(ON)}	Drain-Source On-State Resistance	V _{GS} =-4.5V, I _D =-3A		65	90	mΩ
		V _{GS} =-2.5V, I _D =-3A		89	120	mΩ
Dynamic Characteristics						
C _{iss}	Input Capacitance	V _{DS} =-10V, V _{GS} =0V, f=1.0MHz		480		pF
C _{oss}	Output Capacitance			83		pF
C _{rss}	Reverse Transfer Capacitance			54		pF
Switching Times						
t _{d(on)}	Turn-on Delay Time	V _{DD} =-10V, I _D =-1A, R _L =2.8Ω V _{GS} =-4.5V, R _G =6Ω		11		nS
t _r	Turn-on Rise Time			52		nS
t _{d(off)}	Turn-Off Delay Time			17		nS
t _f	Turn-Off Fall Time			10		nS
Q _g	Total Gate Charge	V _{DS} =-10V, I _D =-3A, V _{GS} =-4.5V		4		nC
Q _{gs}	Gate-Source Charge			0.7		nC
Q _{gd}	Gate-Drain Charge			1.2		nC
Source-Drain Diode Characteristics						
I _{SD}	Source-Drain Current(Body Diode)				-3	A
V _{SD}	Forward on Voltage ^(Note 1)	V _{GS} =0V, I _S =-3A			-1.2	V

Notes 1. Repetitive Rating: Pulse width limited by maximum junction temperature.

Switch Time Test Circuit and Switching Waveforms:

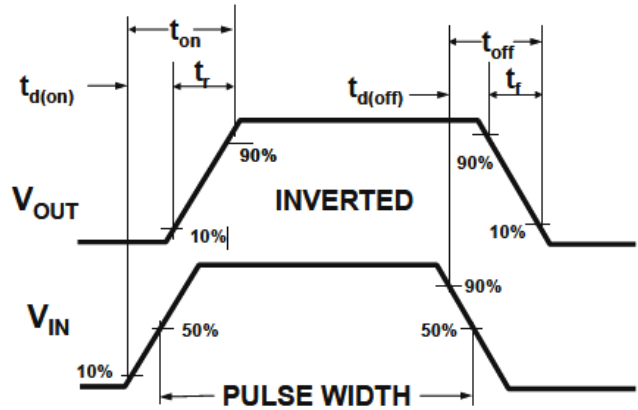
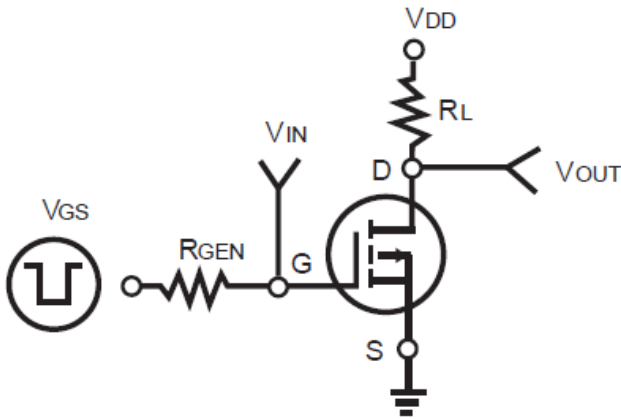

TYPICAL ELECTRICAL AND THERMAL CHARACTERISTICS (Curves)

Figure1. Power Dissipation

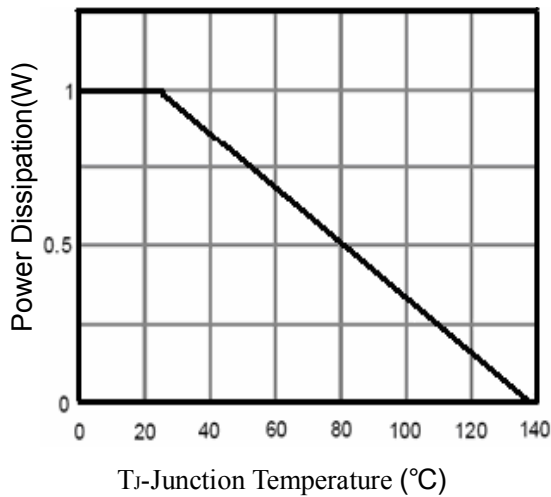

Figure2. Drain Current

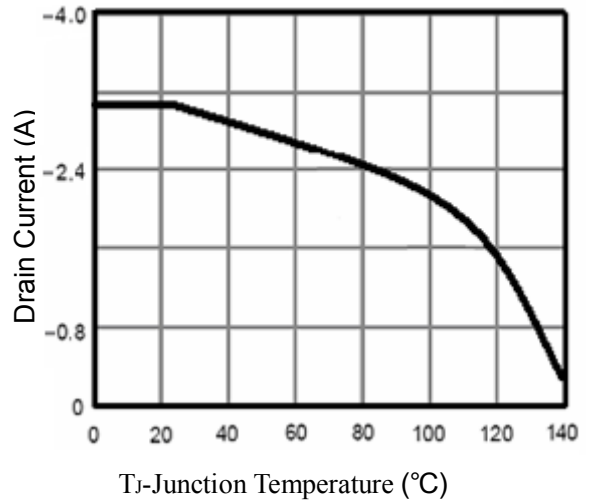

Figure3. Output Characteristics

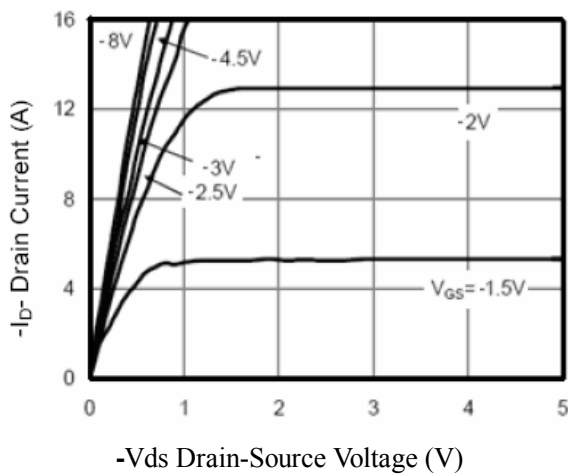

Figure4. Transfer Characteristics

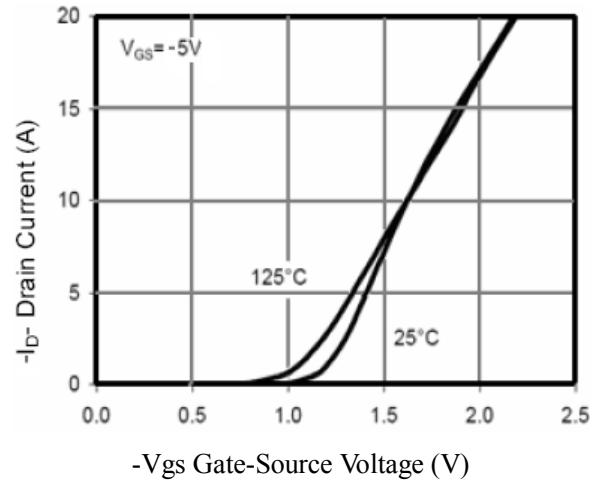

Figure5. Capacitance

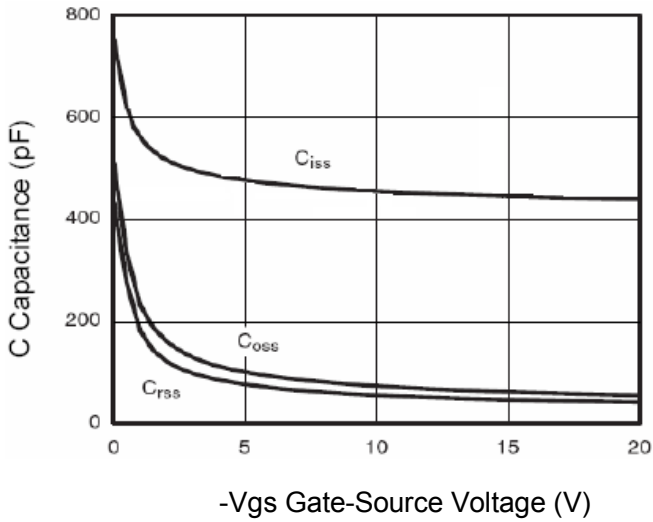

Figure6. $R_{DS(ON)}$ vs Junction Temperature

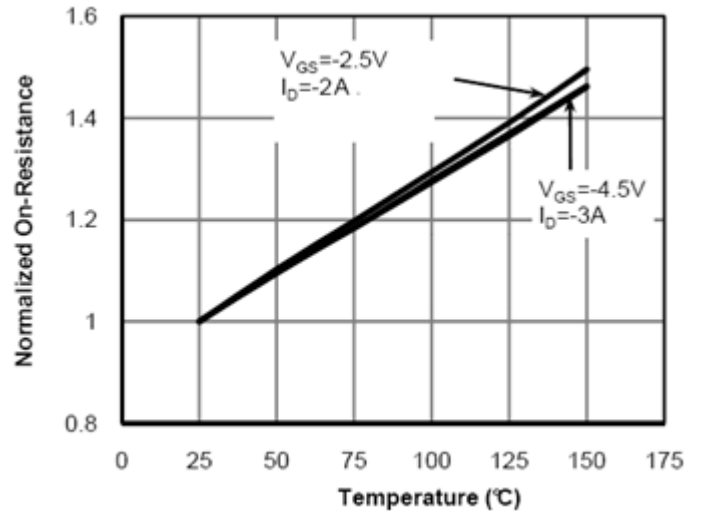

Figure7. Max BV_{DSS} vs Junction Temperature

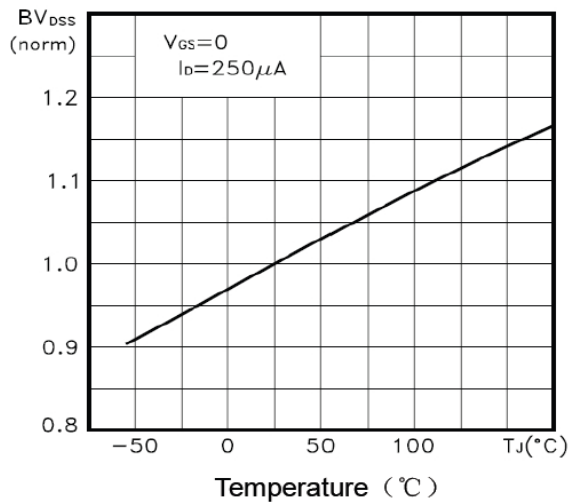

Figure8. $V_{GS(th)}$ vs Junction Temperature

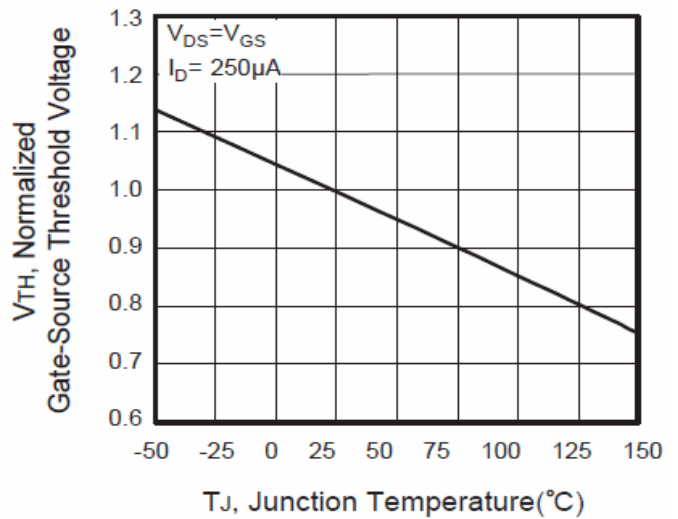

Figure9. Gate Charge Waveforms

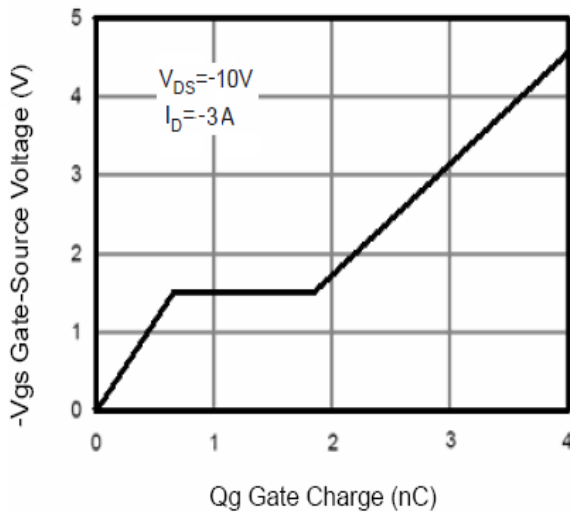

Figure10. Maximum Safe Operating Area

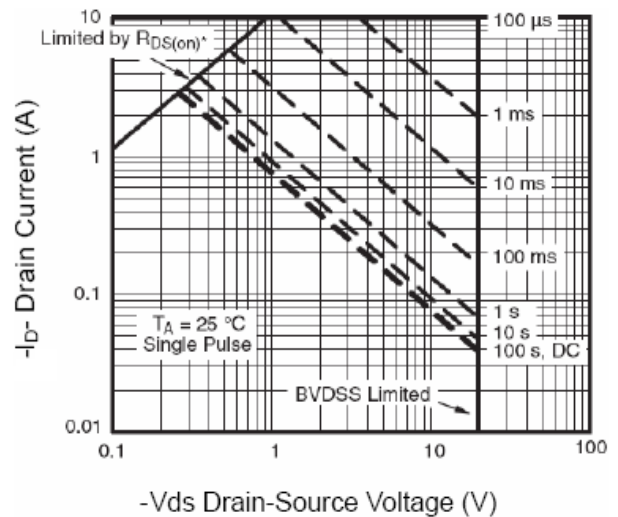
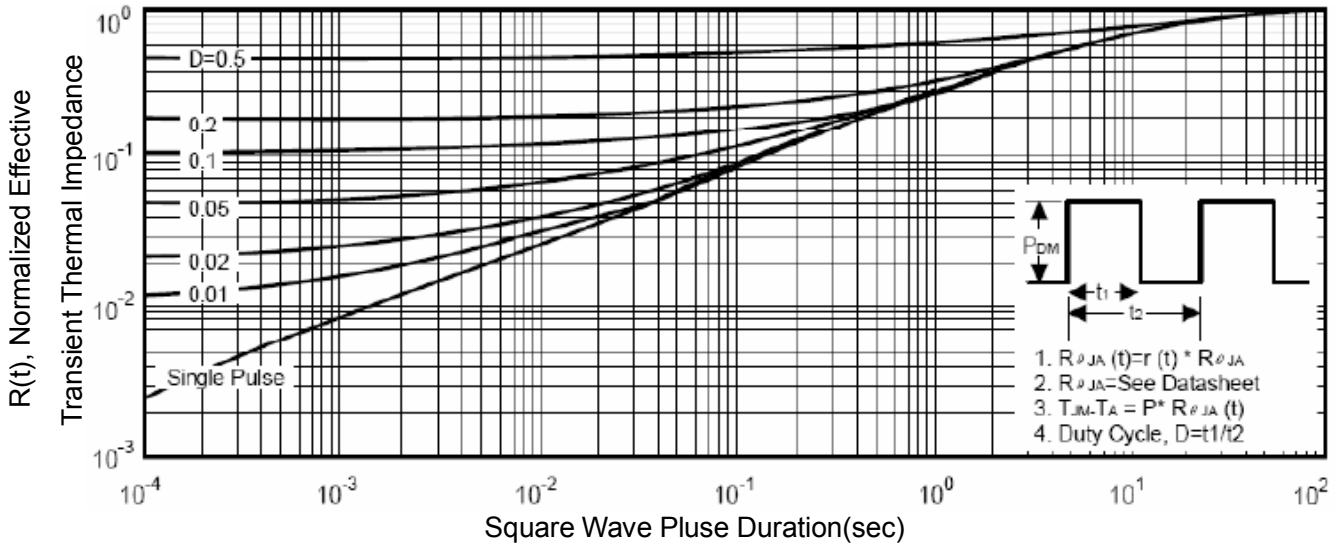
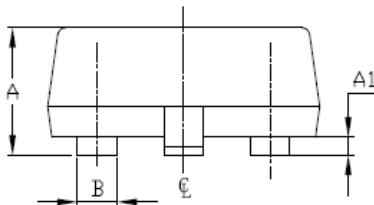
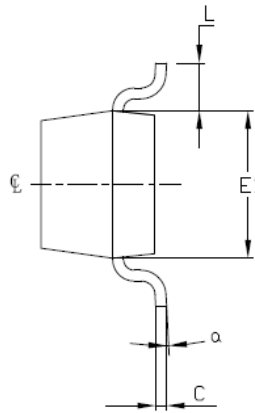
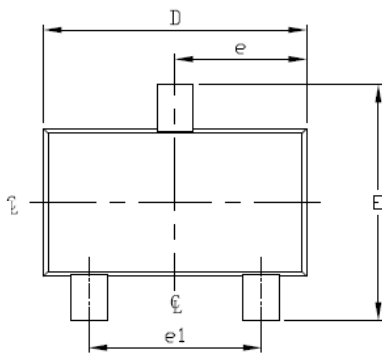

Figure11. Normalized Maximum Transient Thermal Impedance



SOT-23 Package Information



COMMON DIMENSIONS			
SYMBOL	mm		
	MIN	NOM	MAX
A	0.9	1.0	1.1
A1	0.00	0.06	0.1
B	0.3	0.4	0.5
C	0.07	0.09	0.18
D	2.8	2.9	3.04
E	2.1	2.33	2.64
E1	1.2	1.3	1.4
e	1.4	1.45	1.5
e1	1.80	1.90	2.00
L	0.45	0.54	0.63
a	0°	2.5°	7°