

N-Channel Trench Power MOSFET

General Description

The CS3400 uses advanced trench technology to provide excellent $R_{DS(ON)}$, low gate charge and operation with gate voltages as low as 2.5V. This device is suitable for use as a load switch or in PWM applications.

Features

- $V_{DS} = 30V, I_D = 5.8A$
 $R_{DS(ON)} < 30m\Omega @ V_{GS} = 10V$
 $R_{DS(ON)} < 40m\Omega @ V_{GS} = 4.5V$
 $R_{DS(ON)} < 55m\Omega @ V_{GS} = 2.5V$
- High Power and current handling capability
- Lead free product is acquired
- Surface Mount Package

Application

- PWM applications
- Load switch
- Power management

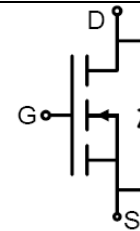

Schematic Diagram

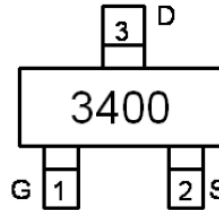

Marking and pin Assignment

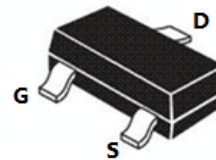

SOT-23-3L top view

Package Marking and Ordering Information

Device Marking	Device	Device Package	Reel Size	Tape width	Quantity
3400	CS3400	SOT-23-3L	Ø180mm	8mm	3000 units

Table 1. Absolute Maximum Ratings (TA=25°C)

Symbol	Parameter	Value	Unit
V_{DS}	Drain-Source Voltage ($V_{GS}=0V$)	30	V
V_{GS}	Gate-Source Voltage ($V_{DS}=0V$)	±12	V
I_D	Drain Current-Continuous	5.8	A
$I_{DM (pluse)}$	Drain Current-Continuous@ Current-Pulsed (Note 1)	30	A
P_D	Maximum Power Dissipation	1.5	W
T_J, T_{STG}	Operating Junction and Storage Temperature Range	-55 To 150	°C

Notes 1.Repetitive Rating: Pulse width limited by maximum junction temperature

Table 2. Thermal Characteristic

Symbol	Parameter	Value	Unit
$R_{\theta JA}$	Thermal Resistance, Junction-to-Ambient	85	°C/W

Table 3. Electrical Characteristics (TA=25°C unless otherwise noted)

Symbol	Parameter	Conditions	Min	Typ	Max	Unit
On/Off States						
BV _{DSS}	Drain-Source Breakdown Voltage	V _{GS} =0V I _D =250μA	30			V
I _{DSS}	Zero Gate Voltage Drain Current	V _{DS} =30V, V _{GS} =0V			1	μA
I _{GSS}	Gate-Body Leakage Current	V _{GS} =±12V, V _{DS} =0V			±100	nA
V _{GS(th)}	Gate Threshold Voltage	V _{DS} =V _{GS} , I _D =250μA	0.6	0.9	1.4	V
g _{FS}	Forward Transconductance	V _{DS} =5V, I _D =4.2A	2	8		S
R _{DS(ON)}	Drain-Source On-State Resistance	V _{GS} =10V, I _D =4.2A		21	30	mΩ
		V _{GS} =4.5V, I _D =4A		25	40	mΩ
		V _{GS} =2.5V, I _D =2A		34	55	mΩ
Dynamic Characteristics						
C _{iss}	Input Capacitance	V _{DS} =15V, V _{GS} =0V, f=1.0MHz		680		pF
C _{oss}	Output Capacitance			108		pF
C _{rss}	Reverse Transfer Capacitance			72		pF
Switching Times						
t _{d(on)}	Turn-on Delay Time	V _{DD} =15V, I _D =1A, R _L =15Ω V _{GS} =10V, R _G =2.5Ω		4		nS
t _r	Turn-on Rise Time			5		nS
t _{d(off)}	Turn-Off Delay Time			27		nS
t _f	Turn-Off Fall Time			5		nS
Q _g	Total Gate Charge	V _{DS} =15V, I _D =4.9A, V _{GS} =10V		10		nC
Q _{gs}	Gate-Source Charge			2		nC
Q _{gd}	Gate-Drain Charge			3		nC
Source-Drain Diode Characteristics						
I _{SD}	Source-Drain Current(Body Diode)				5.8	A
V _{SD}	Forward on Voltage (Note 1)	V _{GS} =0V, I _S =1A		0.78	1.2	V

Notes 1. Repetitive Rating: Pulse width limited by maximum junction temperature.

Switch Time Test Circuit and Switching Waveforms:

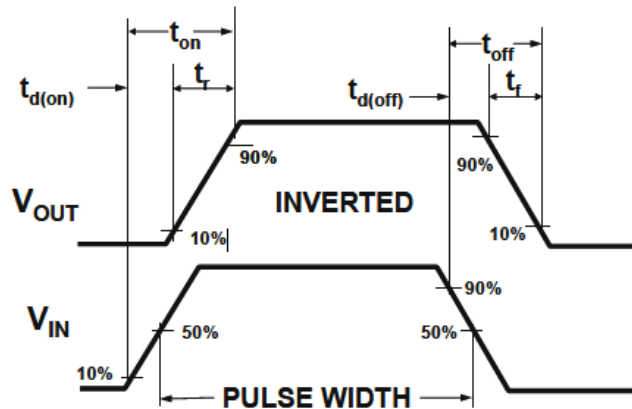
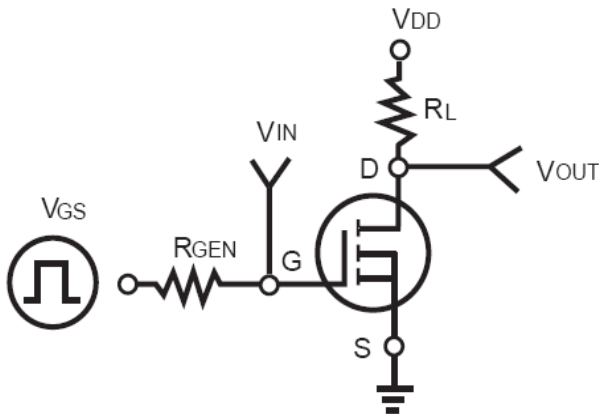

TYPICAL ELECTRICAL AND THERMAL CHARACTERISTICS (Curves)

Figure1. Power Dissipation

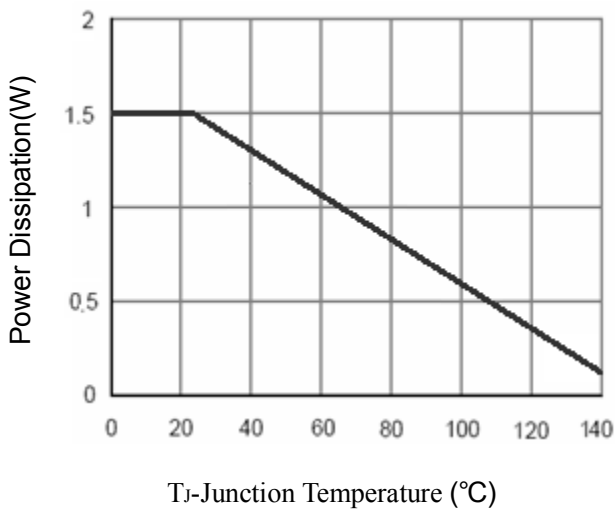

Figure2. Drain Current

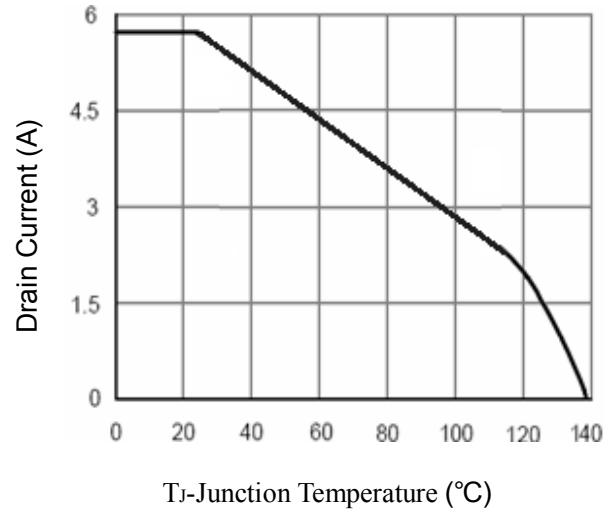

Figure3. Output Characteristics

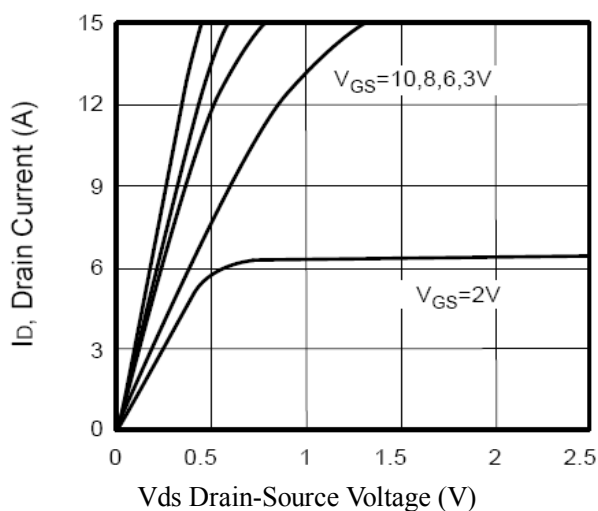

Figure4. Transfer Characteristics

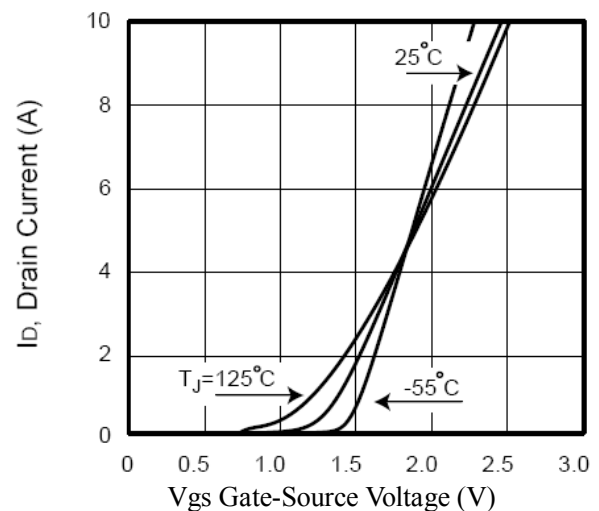

Figure5. Capacitance

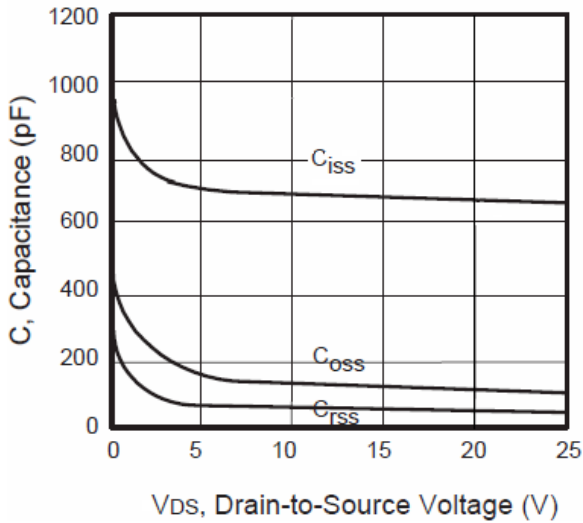

Figure6. $R_{DS(ON)}$ vs Junction Temperature

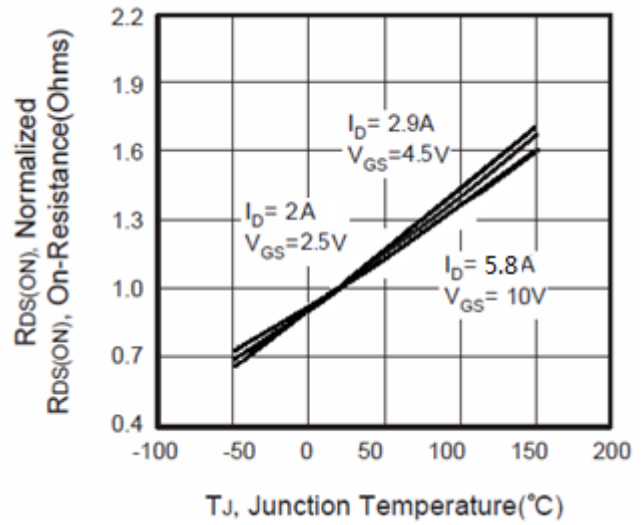

Figure7. Max BV_{DSS} vs Junction Temperature

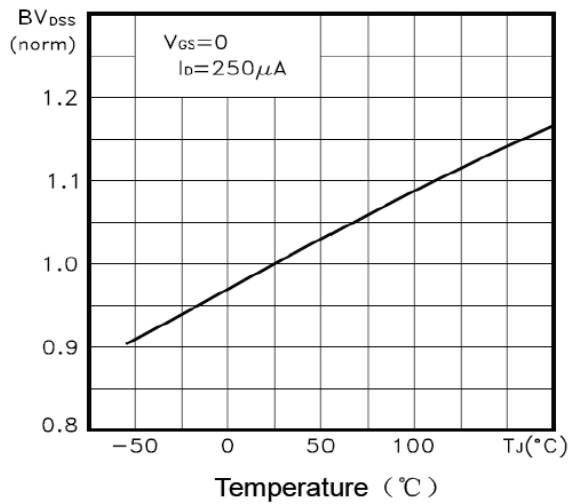

Figure8. $V_{GS(th)}$ vs Junction Temperature

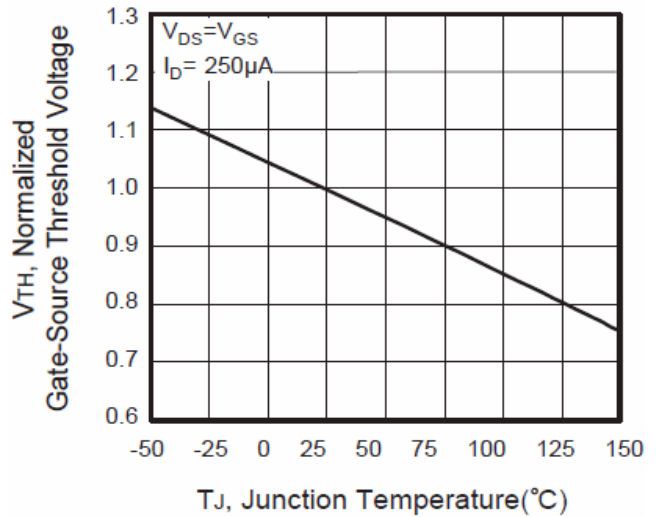

Figure9. Gate Charge Waveforms

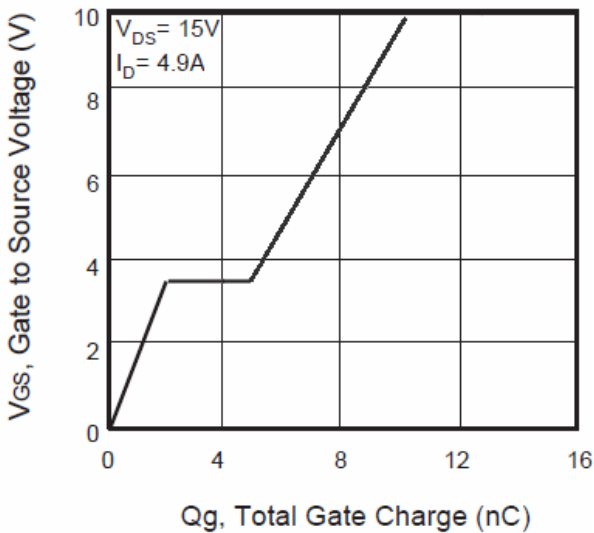

Figure10. Maximum Safe Operating Area

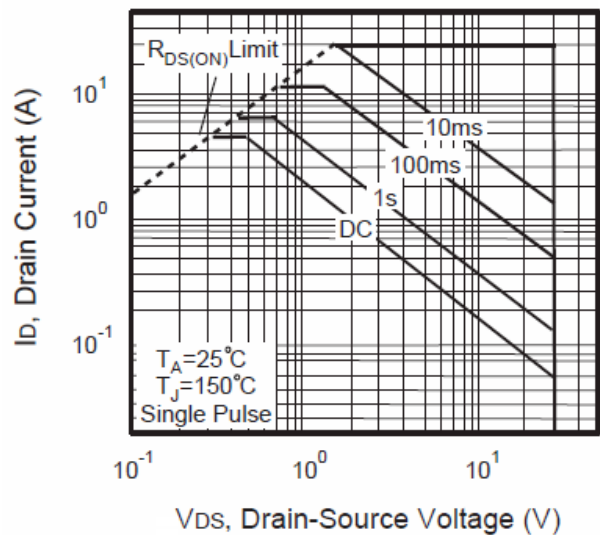
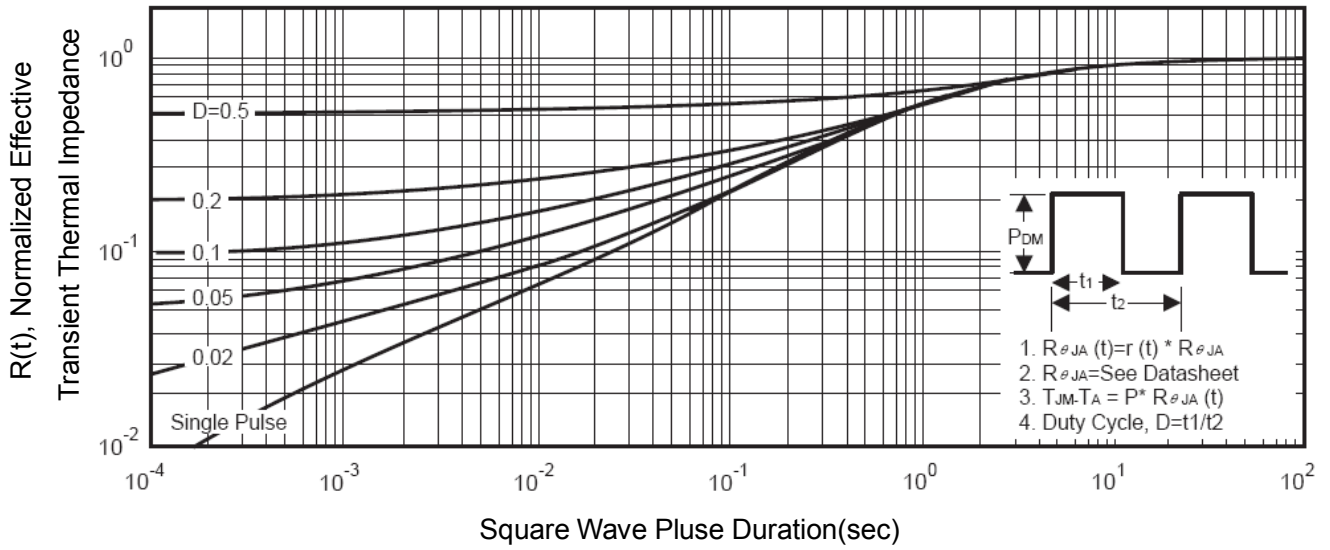

Figure11. Normalized Maximum Transient Thermal Impedance



SOT-23-3L Package Information

