

CS 3950D

B/W Progressive Scan CCD Video Camera



Technical Data

Type Image sensor

Video output pixels
Unit pixel size
Image Area
Scanning lines
TV system
Sync system
Illumination

Video output
Resolution
S/N
Gain

Gamma correction
White-clip level
Power source
Power consumption

Internal sync signal spec

Base clock frequency
H sync frequency
V sync frequency

External sync signal spec

Ext. sync input signal
Input level
Input impedance
Interlace
Polarity
Pulse width
Repeating frequency
Phase difference

Trigger spec

Input level
Input impedance
Capture timing
Pulse width

Electronic shutter spec

Normal Shutter

CS 3950D

1/3" Progressive Scan Interline CCD
ICX204AL-6
1024 (H) x 768 (V)
4.65 (H) x 4.65 (V) μm (Square grid array)
5.8 (H) x 4.92 (V) mm
796 lines
Special format (Non-conforming to EIA)
Internal / External automatic switchover
Standard: 400lx, F 5.6
Minimum: 1lx (F 1.8) (GAIN MAX. approx. 50% video output)
VS 1.0V(p-p)/75 Ohm, DC coupled
770 TV lines (H), 485 lines (V) (350 TV lines)
Standard: 50 dB(p-p)rms
FIX (fixed) gain: Factory-shipped preset level
MANU (manual) gain: Setting through GAIN VR
FIX/MANU switching via rear-panel DIP SW
Fixed at 1.0
Approx. 840mV(p-p) (Excluding SYNC)
DC12V +/-10%, Ripple voltage: 50mV(p-p) or less
Approx. 160mA

29.50MHz (1CLK)
23.23kHz
29.20Hz (Under non-interlace)

HD/VD
2 ~ 5V(p-p) / 2 ~ 4V(p-p) / 75Ohm
75Ohm/High impedance, 10k Ohm (switching via rear-panel SW), (Initial factory setting: High)
1/60s non-interlace or 1/120s 2:1 interlace
Negative
HD: 3.46 +/- 1 μs (LOW), VD: From 125 through 400 μs (LOW)
 $f_H = 23.23 \text{ kHz} \pm 1\%$, $f_V = f_H/796$
HD/VD: 0 +/-5.0 μs

LOW level: 0-0.5V(p-p), HIGH level: 4-5V(p-p)
High impedance (10k Ohm)
Rising edge detection (Positive) Falling edge detection (Negative)
Minimum 2 μs , Maximum 1/8s

Shutter speed setting via rear-panel SW (Initial:OFF)
12 steps selectable (=OFF, 1/60, 1/125, 1/250, 1/500, 1/1000, 1/2000, 1/5000, 1/10000, 1/20000, 1/50000, 1/100000s)

RTS (Random Trigger Shutter)

No.	Reset	Exposure	Sync
1	Non-reset	Rear SW (FIX mode)	Internal
2			Consecutive HD / Consecutive VD IN
3			Consecutive HD / Single VD IN
4		TRIG pulse width (PULSE width mode)	Internal
5			Consecutive HD / Consecutive VD IN
6			Consecutive HD / Single VD IN
7	V-reset	Rear SW (FIX mode)	Internal
8			Consecutive HD IN
9	V-reset	TRIG pulse width (PULSE width mode)	Internal
10			Consecutive HD IN

Technical Data

Type

CS 3950D

Multiple Shutter
Restart / Reset

Multiple shutter via ext. trigger signal and ext. VD signal
Restart / reset available via ext. VD signal (Switching via rear panel DIP SW, Initial OFF)

Partial Scan

No.	Scan mode	Sync	Reset	E-shutter Normal	E-shutter RTS
1	1/2 partial	Internal	Non-reset	Enabled [Option]	Enabled
2			V-reset	Disabled	-----
3		Consecutive HD VD IN	Non-reset	Enabled [Option]	Enabled
4		Consecutive HD (VD) IN	V-reset	Disabled	-----
5	1/4 partial	Internal	Non-reset	Enabled [Option]	Enabled
6			V-reset	Disabled	-----
7		Consecutive HD VD IN	Non-reset	Enabled [Option]	Enabled
8		Consecutive HD (VD) IN	V-reset	Disabled	-----

Mechanical spec

External dimension

44(W) x 29(H) x 78(D) mm

Weight

Approx. 130g

Lens mount

C-Mount

Ambient condition

Operation

Performance guaranteed: Temperature from 0 through 40°C / Humidity from 30 through 90% (no condensing)

Storage

-5°C to 50°C / Humidity 10% to 90% (no condensing)

EMI

-20°C to 60°C / Humidity 10% to 90% (no condensing)

Conform to EN50081-2 (Examination level EN55011-A)

Output Connector

HR10A-10P-12S

Optical black characteristics

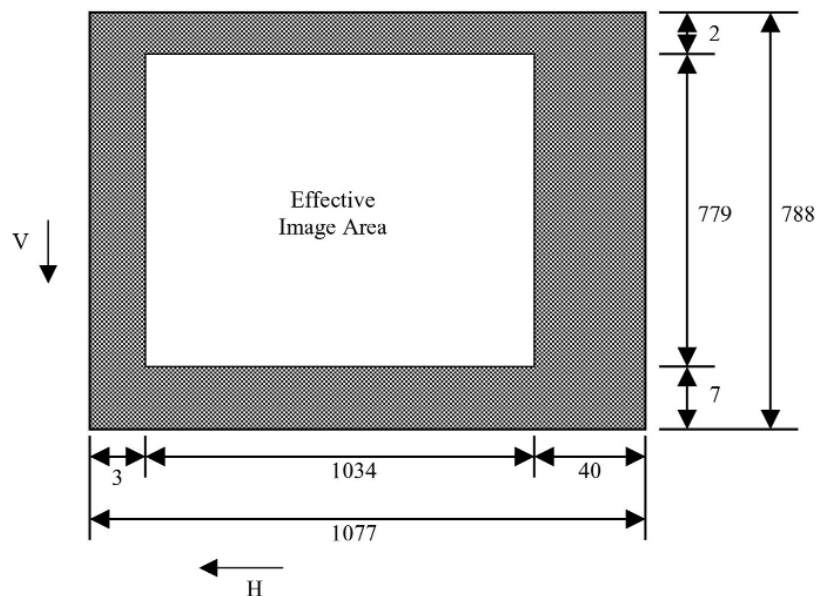

Total pixels : 1077(H) x 788(V)
 Effective pixels : 1034(H) x 779(V)
 Optical black
 Horizontal : 3pixels --- 40pixels
 Vertical : 7pixels --- 2pixels

Relative Spectrum Response

*Including lens characteristics, excluding light source characteristics

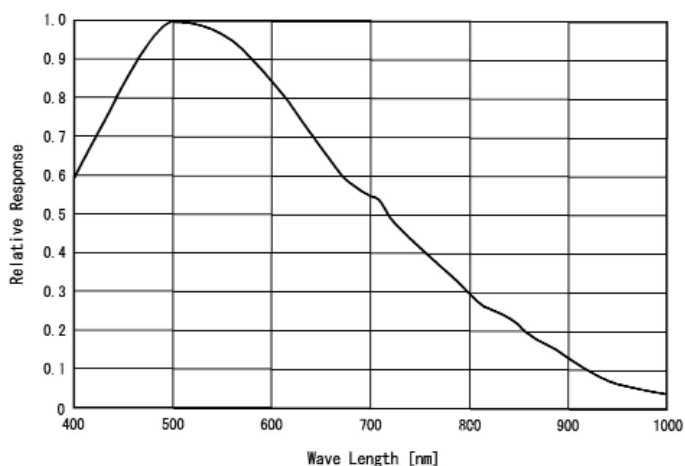

Outline

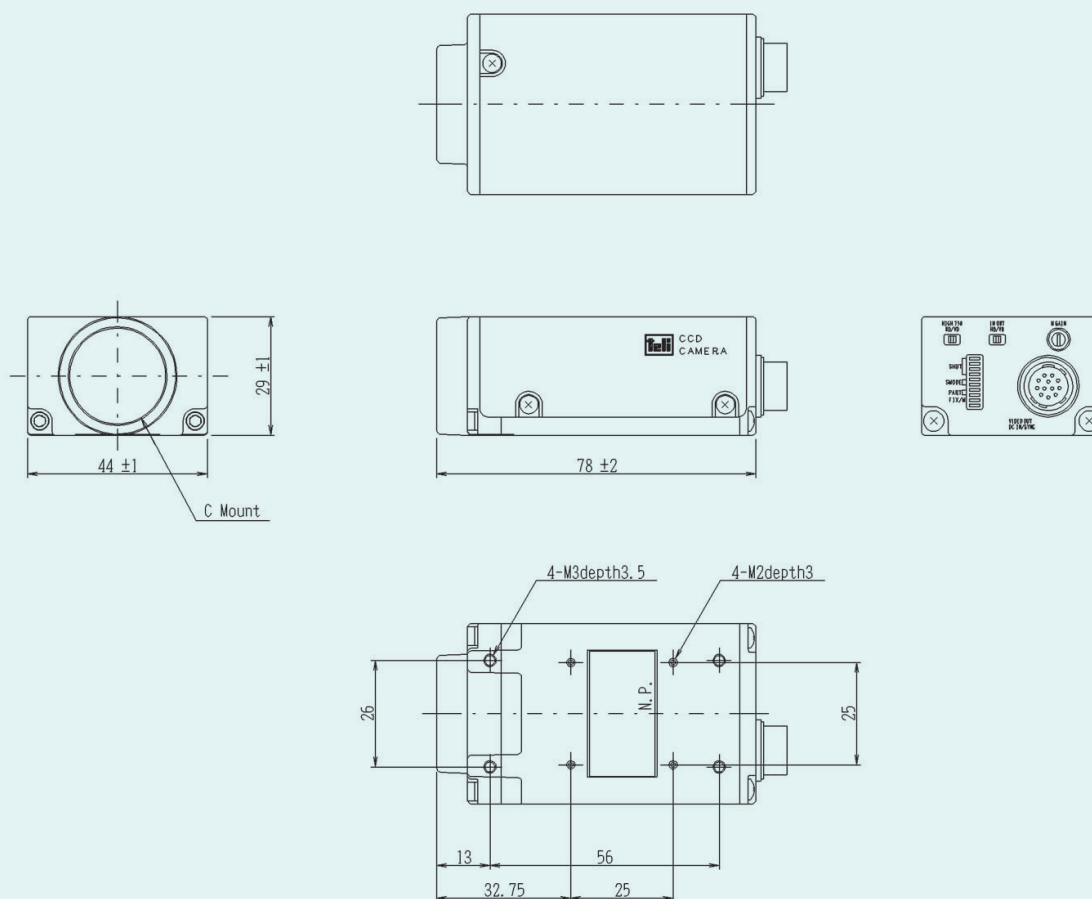

NEW ELECTRONIC TECHNOLOGY Vertriebs-GmbH

Lerchenberg 7 • D 86923 Finning, Germany • Phone: +49(0)88 06 - 92 34-0 • Fax: +49(0)88 06 - 92 34-77

E-mail: info@net-gmbh.com

NET USA, Inc.

3037-45th Street • Highland, IN 46322 • Phone: (219) 934-9042 • Fax: (219) 934-9047

E-mail: info@net-usa-inc.com

www.net-gmbh.com