



# CS3R50 A3

## General Description:

CS3R50 A3, the silicon N-channel Enhanced VDMOSFETs, is obtained by the self-aligned planar Technology which reduce the conduction loss, improve switching performance and enhance the avalanche energy. The transistor can be used in various power switching circuit for system miniaturization and higher efficiency. The package form is TO-251, which accords with the RoHS standard.

## Features:

- I **Fast Switching**
- I **Low ON Resistance**( $R_{dson} \leq 3.0\Omega$ )
- I **Low Gate Charge** (Typical Data:8.5nC)
- I **Low Reverse transfer capacitances**(Typical:4.5pF)
- I **100% Single Pulse avalanche energy Test**

## Applications:

Power switch circuit of electron ballast and adaptor.

**Absolute** ( $T_c = 25^\circ\text{C}$  unless otherwise specified):

$V_{DSS}$	500	V
$I_D$	3	A
$P_D (T_c=25^\circ\text{C})$	35	W
$R_{DS(ON)Typ}$	2.4	$\Omega$

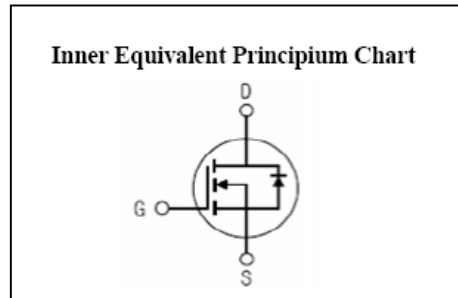
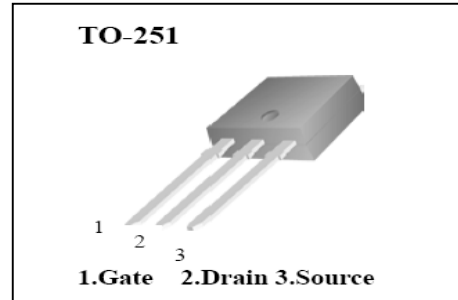

Symbol	Parameter	Rating	Units
$V_{DSS}$	Drain-to-Source Voltage	500	V
$I_D$	Continuous Drain Current	3	A
	Continuous Drain Current $T_c = 100^\circ\text{C}$	2.3	A
$I_{DM}^{a1}$	Pulsed Drain Current	12	A
$V_{GS}$	Gate-to-Source Voltage	$\pm 30$	V
$E_{AS}^{a2}$	Single Pulse Avalanche Energy	110	mJ
$E_{AR}^{a1}$	Avalanche Energy ,Repetitive	6.4	mJ
$I_{AR}^{a1}$	Avalanche Current	1.2	A
$dv/dt^{a3}$	Peak Diode Recovery dv/dt	5	V/ns
$P_D$	Power Dissipation	35	W
	Derating Factor above $25^\circ\text{C}$	0.28	W/ $^\circ\text{C}$
$T_J, T_{stg}$	Operating Junction and Storage Temperature Range	150, $-55$ to 150	$^\circ\text{C}$
$T_L$	Maximum Temperature for Soldering	300	$^\circ\text{C}$

## Electrical Characteristics (Tc= 25°C unless otherwise specified):

OFF Characteristics						
Symbol	Parameter	Test Conditions	Rating			Units
			Min.	Typ.	Max.	
V <sub>DSS</sub>	Drain to Source Breakdown Voltage	V <sub>GS</sub> =0V, I <sub>D</sub> =250μA	500	--	--	V
ΔBV <sub>DSS</sub> /ΔT <sub>J</sub>	Bvdss Temperature Coefficient	ID=250uA, Reference 25°C	--	0.55	--	V/°C
I <sub>DSS</sub>	Drain to Source Leakage Current	V <sub>DS</sub> = 500V, V <sub>GS</sub> = 0V, T <sub>a</sub> = 25°C	--	--	25	μA
		V <sub>DS</sub> = 400V, V <sub>GS</sub> = 0V, T <sub>a</sub> = 125°C			100	
I <sub>GSS(F)</sub>	Gate to Source Forward Leakage	V <sub>DS</sub> = 0V, V <sub>GS</sub> = 30V	--	--	100	nA
I <sub>GSS(R)</sub>	Gate to Source Reverse Leakage	V <sub>DS</sub> = 0V, V <sub>GS</sub> = -30V	--	--	-100	nA

ON Characteristics						
Symbol	Parameter	Test Conditions	Rating			Units
			Min.	Typ.	Max.	
R <sub>DS(ON)</sub>	Drain-to-Source On-Resistance	V <sub>GS</sub> =10V, I <sub>D</sub> =1.5A	--	2.4	3.0	Ω
V <sub>GS(TH)</sub>	Gate Threshold Voltage	V <sub>DS</sub> = V <sub>GS</sub> , I <sub>D</sub> = 250μA	3.0		5.0	V
Pulse width tp ≤ 300μs, δ ≤ 2%						

Dynamic Characteristics						
Symbol	Parameter	Test Conditions	Rating			Units
			Min.	Typ.	Max.	
g <sub>fs</sub>	Forward Trans conductance	V <sub>DS</sub> =15V, I <sub>D</sub> =1.5A		2.8		S
C <sub>iss</sub>	Input Capacitance	V <sub>GS</sub> = 0V V <sub>DS</sub> = 25V f = 1.0MHz	--	300		pF
C <sub>oss</sub>	Output Capacitance		--	34		
C <sub>rss</sub>	Reverse Transfer Capacitance		--	4.5		

Resistive Switching Characteristics						
Symbol	Parameter	Test Conditions	Rating			Units
			Min.	Typ.	Max.	
t <sub>d(ON)</sub>	Turn-on Delay Time	I <sub>D</sub> = 3.0A V <sub>DD</sub> = 250V V <sub>GS</sub> = 10V R <sub>G</sub> = 12Ω	--	10	--	ns
t <sub>r</sub>	Rise Time		--	14	--	
t <sub>d(OFF)</sub>	Turn-Off Delay Time		--	33	--	
t <sub>f</sub>	Fall Time		--	10	--	
Q <sub>g</sub>	Total Gate Charge	I <sub>D</sub> = 3.0A V <sub>DD</sub> = 250V V <sub>GS</sub> = 10V	--	8.5		nC
Q <sub>gs</sub>	Gate to Source Charge		--	1.9		
Q <sub>gd</sub>	Gate to Drain ("Miller") Charge		--	3.7		

Source-Drain Diode Characteristics						
Symbol	Parameter	Test Conditions	Rating			Units
			Min.	Typ.	Max.	
$I_S$	Continuous Source Current (Body Diode)		--	--	3	A
$I_{SM}$	Maximum Pulsed Current (Body Diode)		--	--	12	A
$V_{SD}$	Diode Forward Voltage	$I_S=3.0A, V_{GS}=0V$	--	--	1.5	V
$t_{rr}$	Reverse Recovery Time	$I_S=3.0A, T_j = 25^\circ C$ $dI_F/dt=100A/us,$ $V_{GS}=0V$	--	65	--	ns
$Q_{rr}$	Reverse Recovery Charge		--	145	--	nC
$I_{rrm}$	Reverse Recovery Current			4.6		A
Pulse width $t_p \leq 300\mu s, \delta \leq 2\%$						

Symbol	Parameter	Typ.	Units
$R_{\theta JC}$	Junction-to-Case	3.57	$^\circ C/W$
$R_{\theta JA}$	Junction-to-Ambient	62.5	$^\circ C/W$

<sup>a1</sup>: Repetitive rating; pulse width limited by maximum junction temperature

<sup>a2</sup>:  $L=10.0mH, I_D=4.7A, Start T_j=25^\circ C$

<sup>a3</sup>:  $I_{SD}=3A, di/dt \leq 100A/us, V_{DD} \leq BV_{DS}, Start T_j=25^\circ C$

## Characteristics Curve:

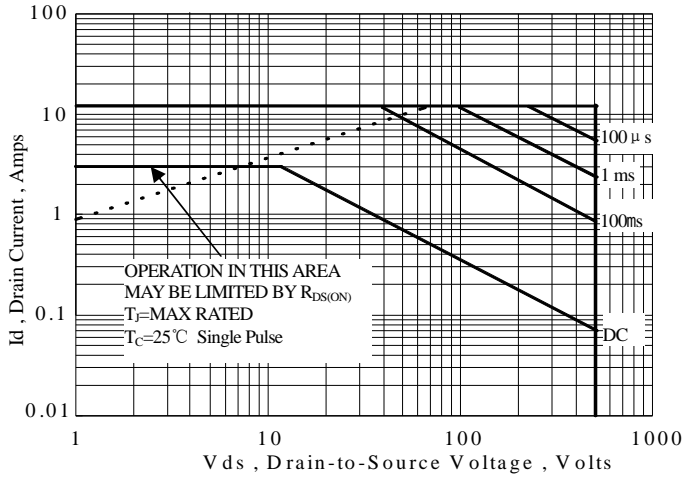

Figure 1 Maximum Forward Bias Safe Operating Area

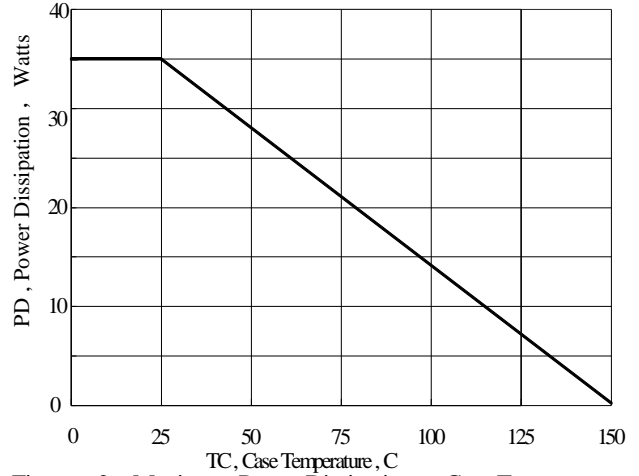

Figure 2 Maximum Power Dissipation vs Case Temperature

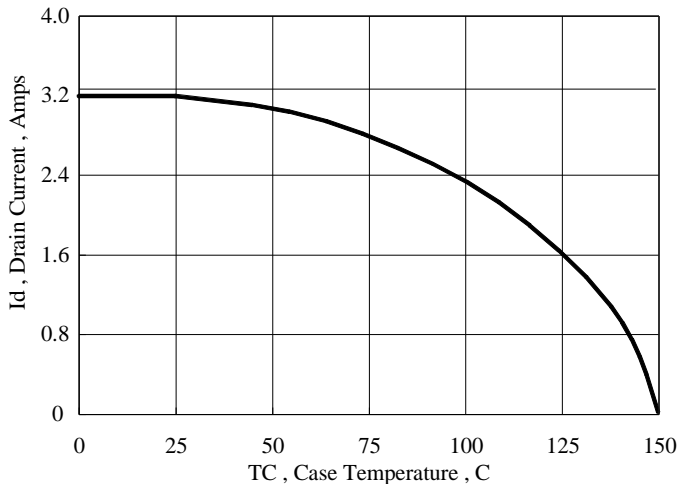

Figure 3 Maximum Continuous Drain Current vs Case Temperature

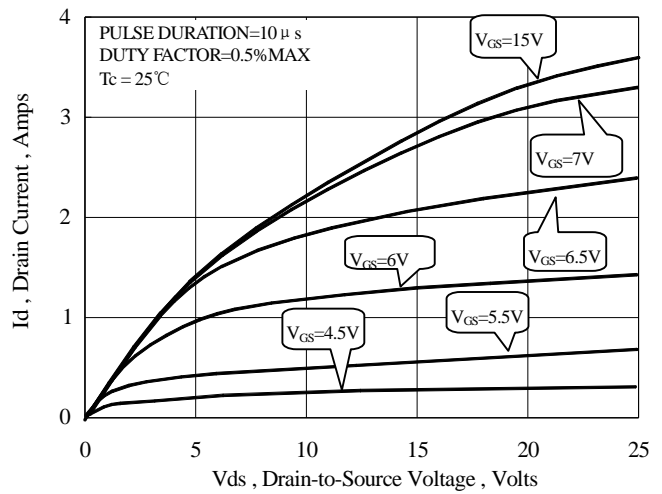

Figure 4 Typical Output Characteristics

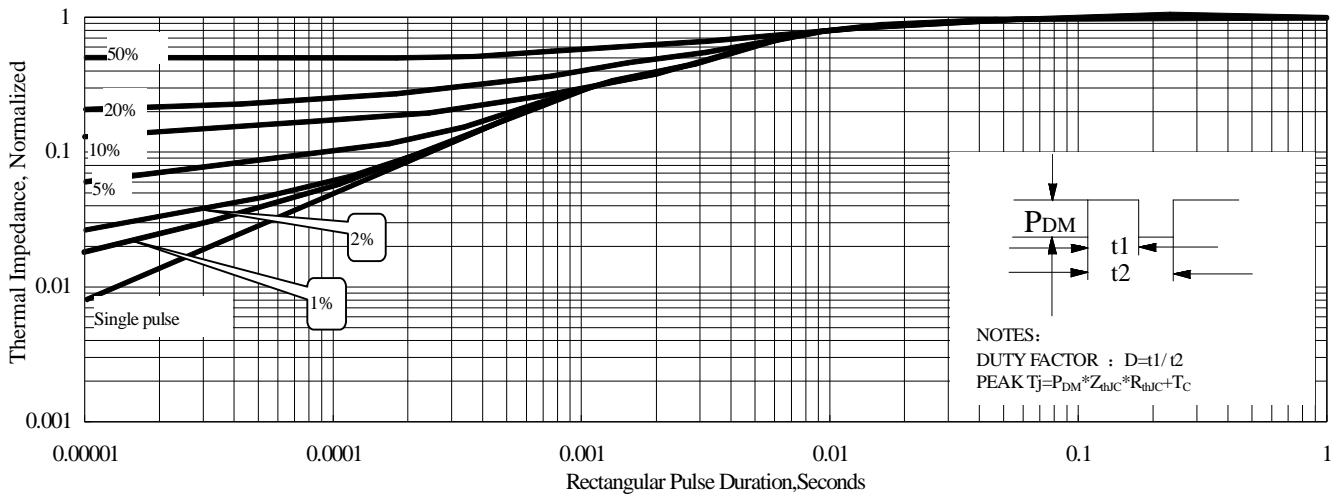

Figure 5 Maximum Effective Thermal Impedance, Junction to Case

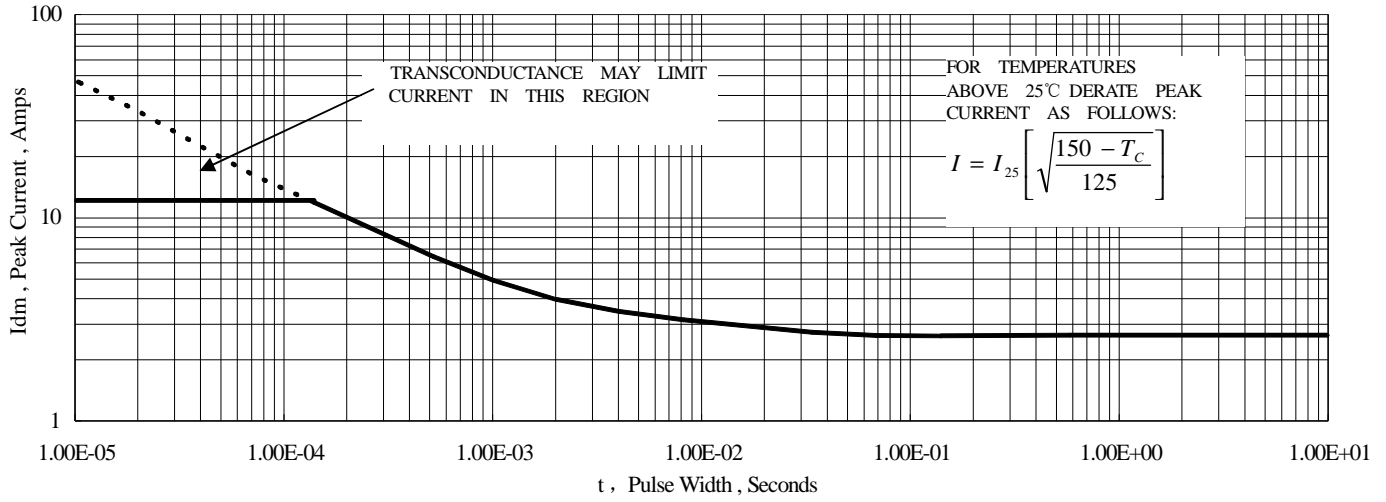

Figure 6 Maximum Peak Current Capability

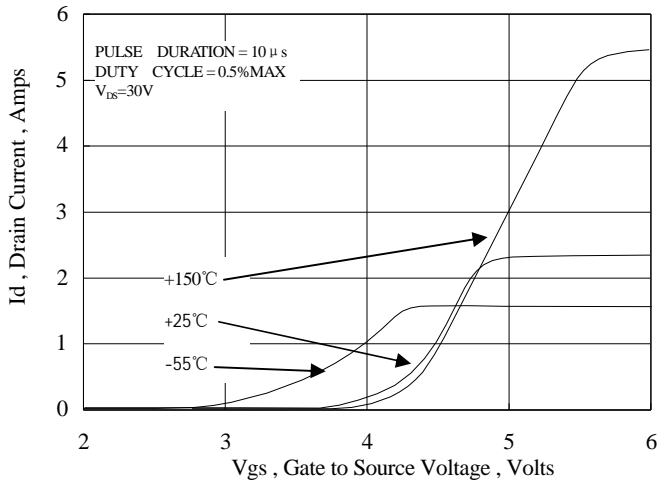

Figure 7 Typical Transfer Characteristics

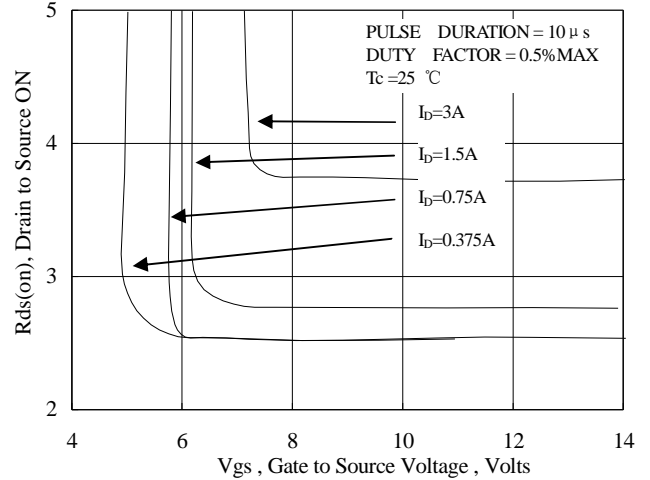

Figure 8 Typical Drain to Source ON Resistance vs Gate Voltage and Drain Current

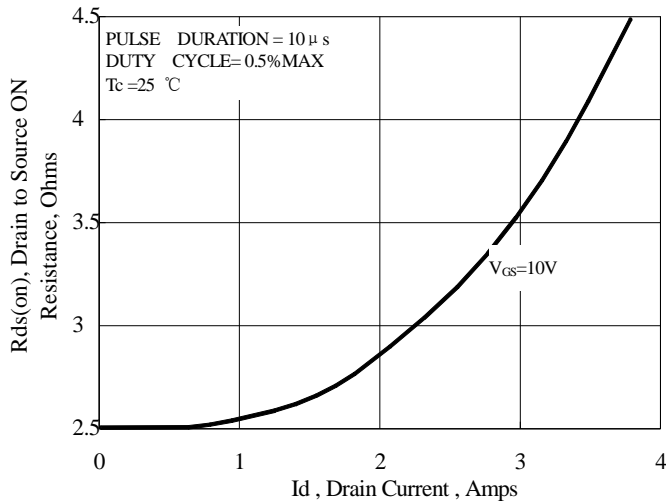

Figure 9 Typical Drain to Source ON Resistance vs Drain Current

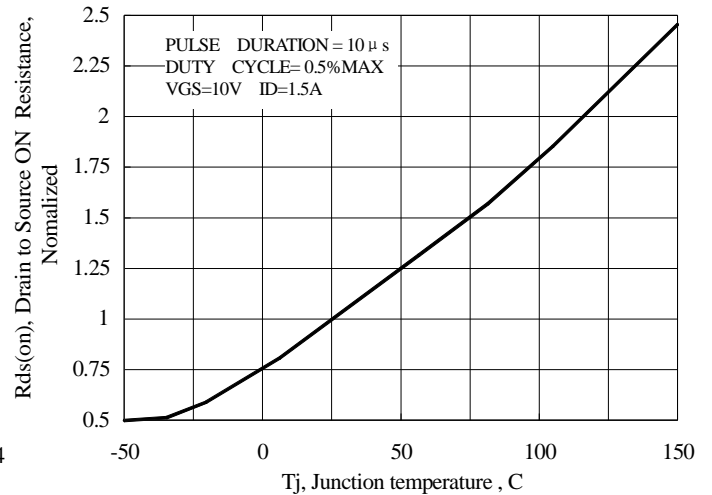

Figure 10 Typical Drain to Source on Resistance vs Junction Temperature

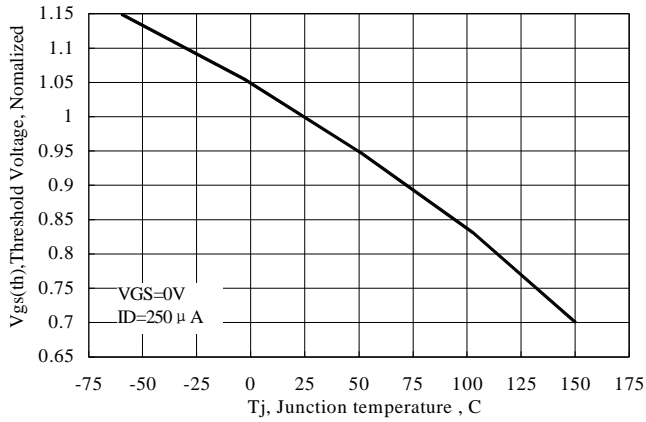

Figure 11 Typical Theshold Voltage vs Junction Temperature

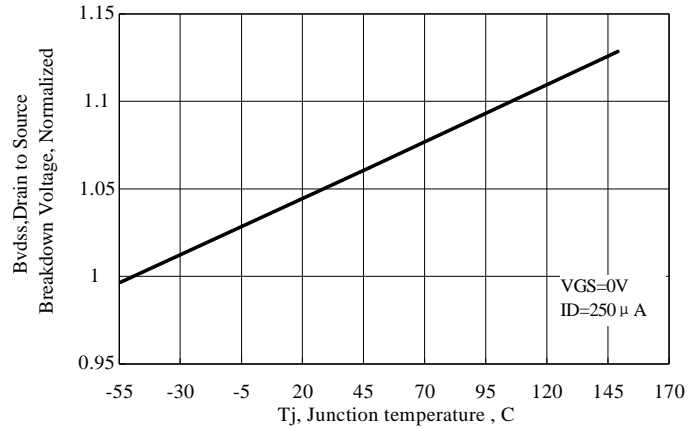

Figure 12 Typical Breakdown Voltage vs Junction Temperature

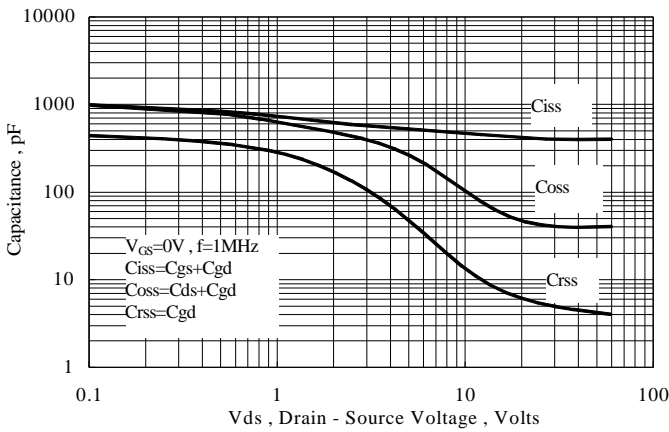

Figure 13 Typical Capacitance vs Drain to Source Voltage

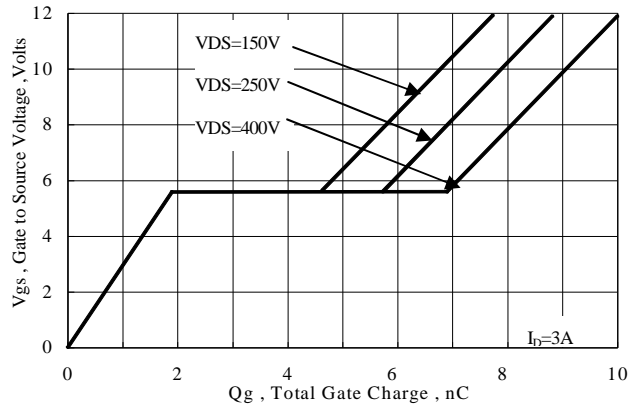

Figure 14 Typical Gate Charge vs Gate to Source Voltage

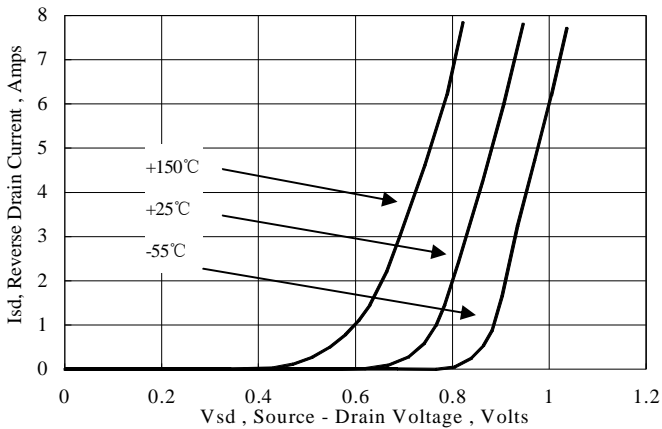

Figure 15 Typical Body Diode Transfer Characteristics

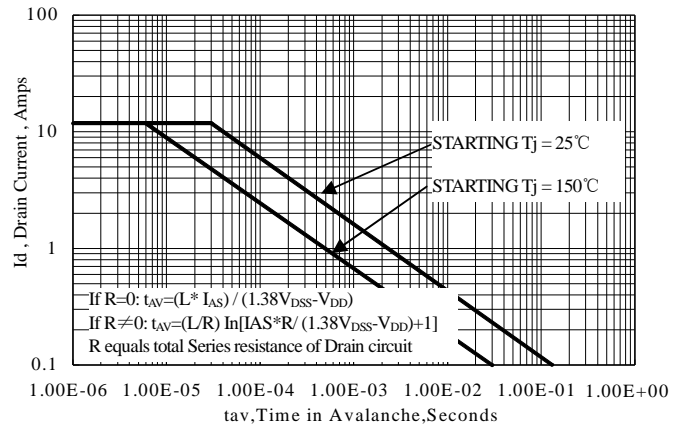

Figure 16 Unclamped Inductive Switching Capability

## Test Circuit and Waveform

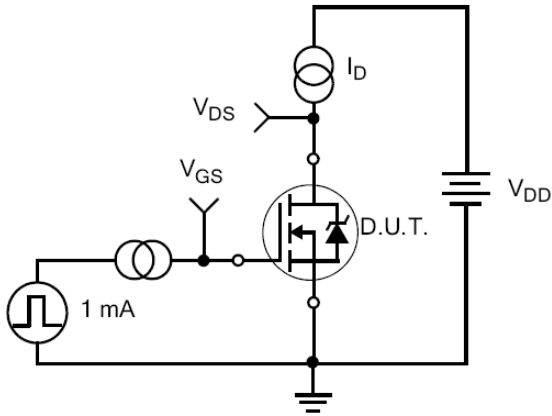

Figure 17. Gate Charge Test Circuit

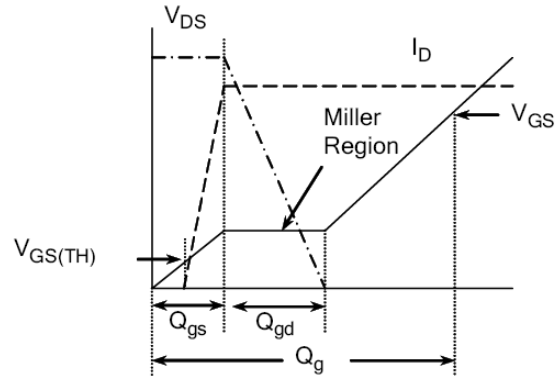

Figure 18. Gate Charge Waveform

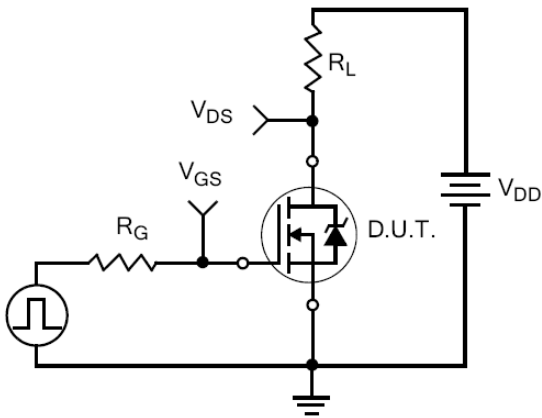

Figure 19. Resistive Switching Test Circuit

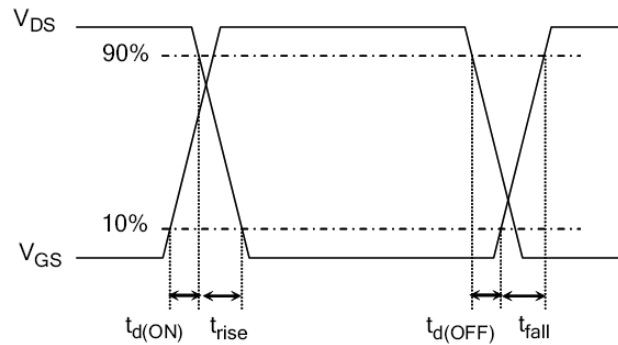

Figure 20. Resistive Switching Waveforms

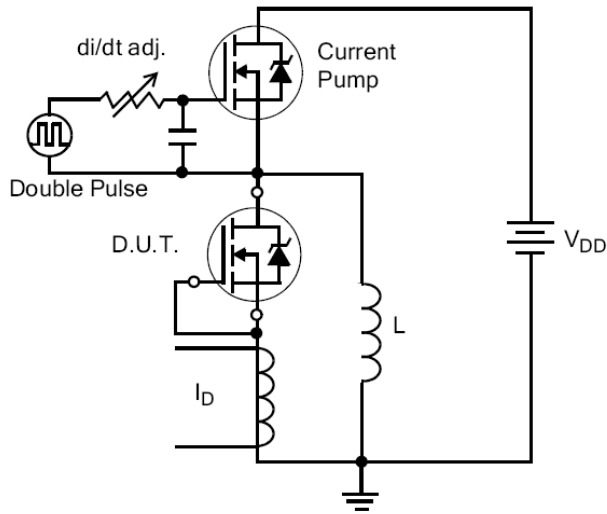

Figure 21. Diode Reverse Recovery Test Circuit

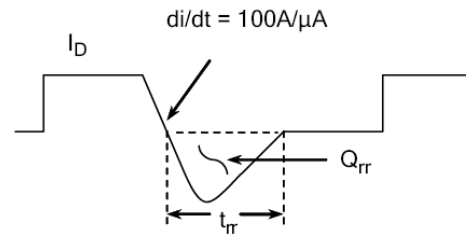

Figure 22. Diode Reverse Recovery Waveform

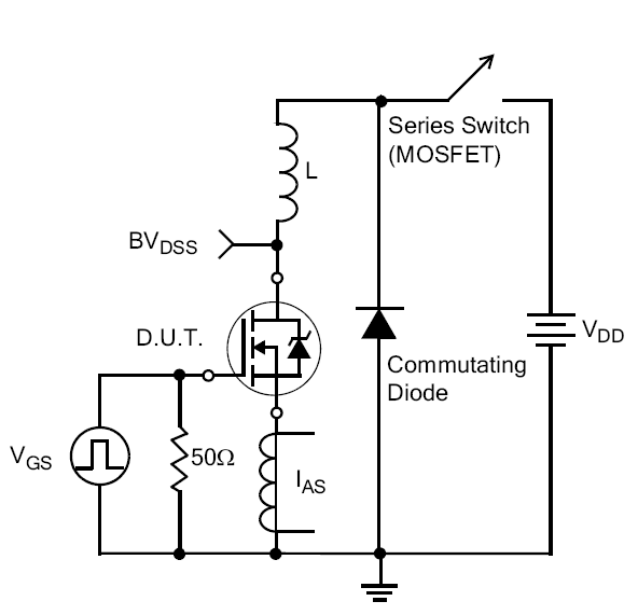

Figure 23. Unclamped Inductive Switching Test Circuit

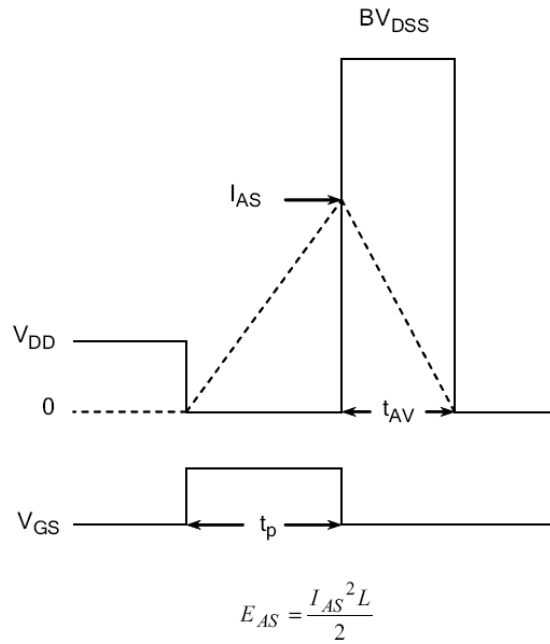
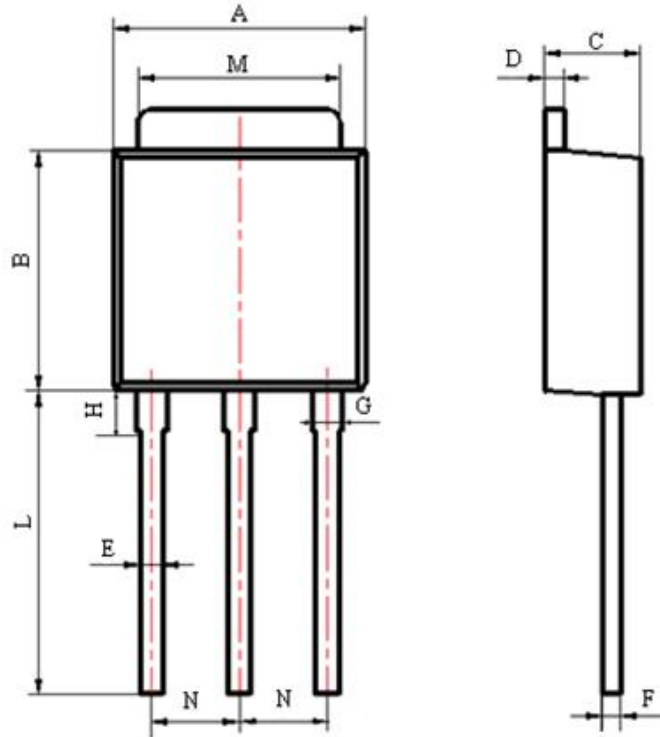

Figure 24. Unclamped Inductive Switching Waveforms



## Package Information:



Items	Values(mm)	
	MIN	MAX
A	6.30	6.90
B	5.70	6.30
C	2.10	2.50
D	0.30	0.60
E	0.50	0.70
F	0.30	0.60
G	0.70	1.00
H	1.60	2.40
L	7.70	9.80
	6.00	6.30
	4.50	5.80
	2.10	3.70
M	5.10	5.50
N	2.09	2.49

TO-251 Package

