

Low Cost, 20-Bit, Stereo, Audio D/A Converter

Features

- 20-Bit Conversion
- 108 dB Signal-to-Noise-Ratio (EIAJ)
- 100 dB Dynamic Range
- Single-Ended Outputs
- Complete Stereo DAC System
 - 128X Interpolation Filter
 - Delta-Sigma DAC
 - Analog Post Filter
- Low Clock Jitter Sensitivity
- Filtered Line-Level Outputs
 - Linear Phase Filtering
 - Zero Phase Error Between Channels
- Digital De-emphasis for 32 kHz, 44.1 kHz & 48 kHz

Description

The CS4327 is a complete stereo digital-to-analog output system. In addition to the traditional D/A function, the CS4327 includes a digital interpolation filter followed by an 128X oversampled delta-sigma modulator. The modulator output controls the reference voltage input to an ultra-linear analog low-pass filter. This architecture allows for infinite adjustment of sample rate between 1 and 50 kHz while maintaining linear phase response simply by changing the master clock frequency.

The CS4327 also includes an extremely flexible serial port utilizing mode select pins to support multiple interface formats.

The master clock can be either 256, 384, or 512 times the input sample rate, supporting various audio environments.

ORDERING INFO

CS4327-KS -10 to 70 °C 16-pin Plastic SSOP
CDB4327 CS4327 Evaluation Board

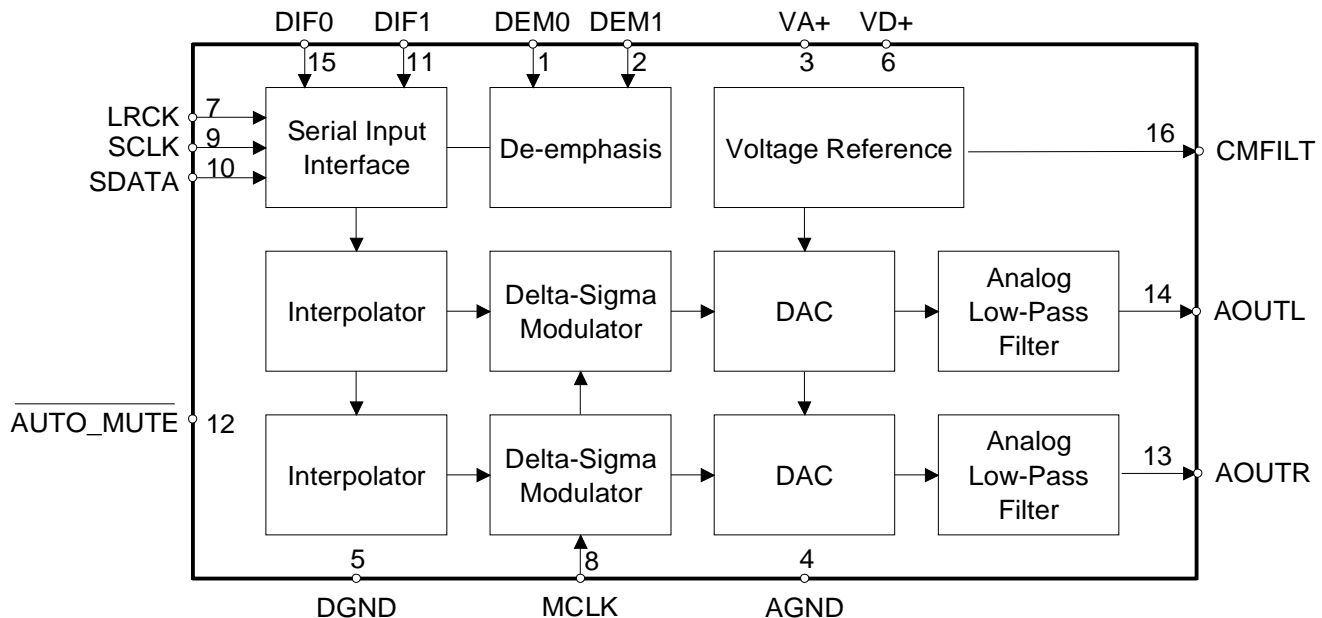

ANALOG CHARACTERISTICS ($T_A = 25\text{ }^\circ\text{C}$; Internal SCLK; Full-Scale Output Sine wave, 997 Hz; 12.288 MHz MCLK; $F_s = 48\text{ kHz}$; Input Data = 20 Bits; SCLK = 3.072 MHz; $R_L = 10\text{ k}\Omega$; $V_{D+} = V_{A+} = 5\text{ V}$; Logic 1 = V_{D+} , Logic 0 = DGND; Measurement Bandwidth is 10 Hz to 20 kHz, unweighted, unless otherwise specified.)

Parameter	Symbol	Min	Typ	Max	Unit
Specified Temperature Operating Range	T_A	-10	-	70	$^\circ\text{C}$
Dynamic Performance					
Dynamic Range (Note 1)					
20-Bit (A-Weighted)		93	97	-	dB
18-Bit (A-Weighted)		96	100	-	dB
16-Bit (A-Weighted)		-	97	-	dB
16-Bit (A-Weighted)		-	100	-	dB
16-Bit (A-Weighted)		-	93	-	dB
16-Bit (A-Weighted)		-	95	-	dB
Total Harmonic Distortion + Noise (Note 1)	THD+N				
20-Bit 0 dB		-87	-93	-	dB
20-Bit -20 dB		-	-77	-	dB
20-Bit -60 dB		-33	-37	-	dB
18-Bit 0 dB		-	-93	-	dB
18-Bit -20 dB		-	-77	-	dB
18-Bit -60 dB		-	-37	-	dB
16-Bit 0 dB		-	-93	-	dB
16-Bit -20 dB		-	-77	-	dB
16-Bit -60 dB		-	-37	-	dB
Idle Channel Noise / Signal-to-Noise-Ratio (Note 2)		-	108	-	dBFS
Interchannel Isolation (1 kHz)		-	-105	-	dB
Combined Digital and Analog Filter Characteristics					
Frequency Response 10 Hz to 20 kHz $F_s = 48\text{ kHz}$		-	± 0.1	-	dB
Deviation from linear phase		-	± 0.5	-	deg
Passband: to -0.1 dB corner		0	-	0.4535	F_s
Passband Ripple		-	-	± 0.002	dB
StopBand		0.5465	-	-	F_s
StopBand Attenuation		72	-	-	dB
Group Delay (Note 3)		-	$25/F_s$	-	s
De-emphasis Error		-	-	± 0.2	dB

- Notes:
1. Triangular PDF Dithered Data
 2. Auto-mute enabled. See parameter definitions.
 3. Group Delay for $F_s = 48\text{ kHz}$
 $25/48\text{ kHz} = 520\text{ }\mu\text{s}$

ANALOG CHARACTERISTICS (Continued)

Parameter	Symbol	Min	Typ	Max	Unit
dc Accuracy					
Interchannel Gain Mismatch		-	0.1	-	dB
Gain Error		-	±2	±5	%
Gain Drift		-	200	-	ppm/°C
Analog Output					
Full Scale Output Voltage		0.95	1.0	1.05	Vrms
Load Resistance		6	-	-	kΩ
Load Capacitance		-	-	100	pF
Output Common Mode Voltage		-	2.3	-	V

POWER AND THERMAL CHARACTERISTICS ($T_A = 25\text{ °C}$; Internal SCLK; Full-Scale Output Sine wave, 997 Hz; 12.288 MHz MCLK; $F_s = 48\text{ kHz}$; Input Data = 20 Bits; SCLK = 3.072 MHz; $R_L = 10\text{ k}\Omega$; $VD+ = VD+ = 5\text{ V}$; Logic 1 = $VD+$, Logic 0 = $DGND$; Measurement Bandwidth is 10 Hz to 20 kHz, unweighted, unless otherwise specified.)

Parameter	Symbol	Min	Typ	Max	Unit	
Power Supply Current	Normal Operation					
		IA+	-	25	-	mA
		ID+	-	12	-	mA
		(IA+) + (ID+)	-	37	43	mA
Power Dissipation	Power Down					
		(IA+) + (ID+)	-	300	-	μA
Power Dissipation	Normal Operation					
	Power-down		-	185	215	mW
Power Supply Rejection Ratio (1 kHz)	PSRR	-	60	-	dB	
Allowable Junction Temperature		-	-	135	°C	
Junction to Ambient Thermal Impedance	Θ_{JA}	-	120	-	°C/W	

SWITCHING CHARACTERISTICS ($T_A = 25\text{ }^\circ\text{C}$; $V_{A+} = 5.0\text{ V}$; Inputs: Logic 0 = 0 V, Logic 1 = V_{D+} , $C_L = 20\text{ pF}$)

Parameter	Symbol	Min	Typ	Max	Unit
Input Sample Rate	F_s	1	-	50	kHz
MCLK Pulse Width High MCLK/LRCK = 512		10	-	-	ns
MCLK Pulse Width Low MCLK/LRCK = 512		10	-	-	ns
MCLK Pulse Width High MCLK/LRCK = 384		21	-	-	ns
MCLK Pulse Width Low MCLK/LRCK = 384		21	-	-	ns
MCLK Pulse Width High MCLK/LRCK = 256		31	-	-	ns
MCLK Pulse Width Low MCLK/LRCK = 256		31	-	-	ns
External SCLK Mode					
SCLK Pulse Width Low	t_{sckl}	20	-	-	ns
SCLK Pulse Width High	t_{sckh}	20	-	-	ns
SCLK Period	t_{sckw}	$\frac{1}{128(F_s)}$	-	-	ns
SCLK rising to LRCK edge delay	t_{slrd}	20	-	-	ns
SCLK rising to LRCK edge setup time	t_{slrs}	20	-	-	ns
SDATA valid to SCLK rising setup time	t_{sdhrs}	20	-	-	ns
SCLK rising to SDATA hold time	t_{sdh}	20	-	-	ns
Internal SCLK Mode					
SCLK Period SCLK/LRCK = 64	t_{sckw}	$\frac{1}{64(F_s)}$	-	-	ns
SCLK rising to LRCK edge	t_{sckr}	-	$\frac{t_{sckw}}{2}$	-	ns
SDATA valid to SCLK rising setup time	t_{sdhrs}	$\frac{1}{512(F_s)} + 10$	-	-	ns
SCLK rising to SDATA hold time MCLK/LRCK = 256 or 512	t_{sdh}	$\frac{1}{512(F_s)} + 15$	-	-	ns
SCLK rising to SDATA hold time MCLK/LRCK = 384	t_{sdh}	$\frac{1}{384(F_s)} + 15$	-	-	ns

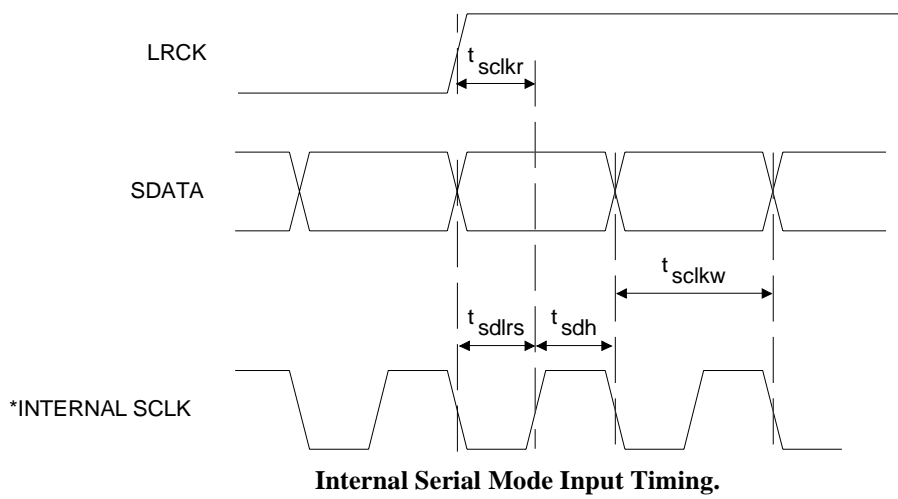
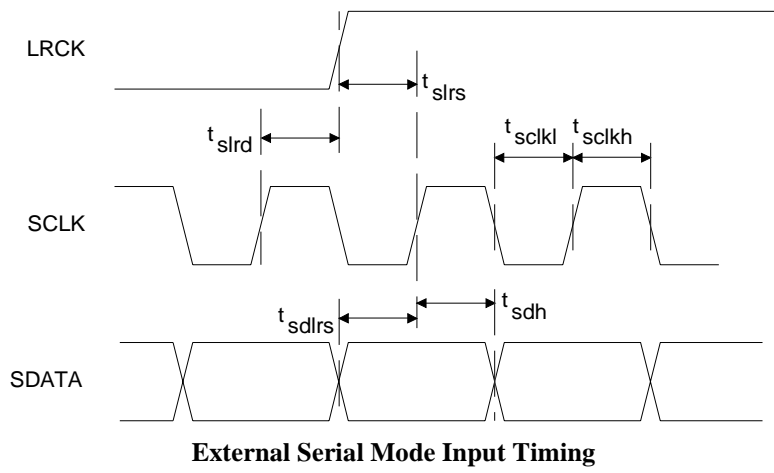

- * The SCLK pin must be terminated to ground.
The SCLK pulses shown are internal to the CS4327

DIGITAL CHARACTERISTICS ($T_A = 25\text{ }^\circ\text{C}$; $V_{D+} = 5\text{ V} \pm 5\%$)

Parameter	Symbol	Min	Typ	Max	Unit
High-Level Input Voltage	V_{IH}	2.0	-	-	V
Low-Level Input Voltage	V_{IL}	-	-	0.8	V
Input Leakage Current		-	-	± 10.0	μA
Digital Input Capacitance		-	10	-	pF

ABSOLUTE MAXIMUM RATINGS (AGND = DGND = 0 V; all voltages with respect to ground.)

Parameter	Symbol	Min	Max	Unit	
DC Power Supply:	Positive Analog	V_{A+}	-0.3	6.0	V
	Positive Digital	V_{D+}	-0.3	6.0	V
	$ V_{A+} - V_{D+} $		0.0	0.4	V
Input Current, Any Pin Except Supplies	I_{in}	-	± 10	mA	
Digital Input Voltage	V_{IND}	-0.3	$(V_{D+}) + 0.4$	V	
Ambient Operating Temperature (power applied)	T_A	-55	125	$^\circ\text{C}$	
Storage Temperature	T_{stg}	-65	150	$^\circ\text{C}$	

WARNING: Operation at or beyond these limits may result in permanent damage to the device.
 Normal operation is not guaranteed at these extremes.

RECOMMENDED OPERATING CONDITIONS

(AGND = DGND = 0 V; all voltages with respect to ground.)

Parameter	Symbol	Min	Typ	Max	Unit	
DC Power Supply:	Positive Analog	V_{A+}	4.75	5.0	5.25	V
	Positive Digital	V_{D+}	4.75	5.0	5.25	V
	$ V_{A+} - V_{D+} $		-	-	0.1	V

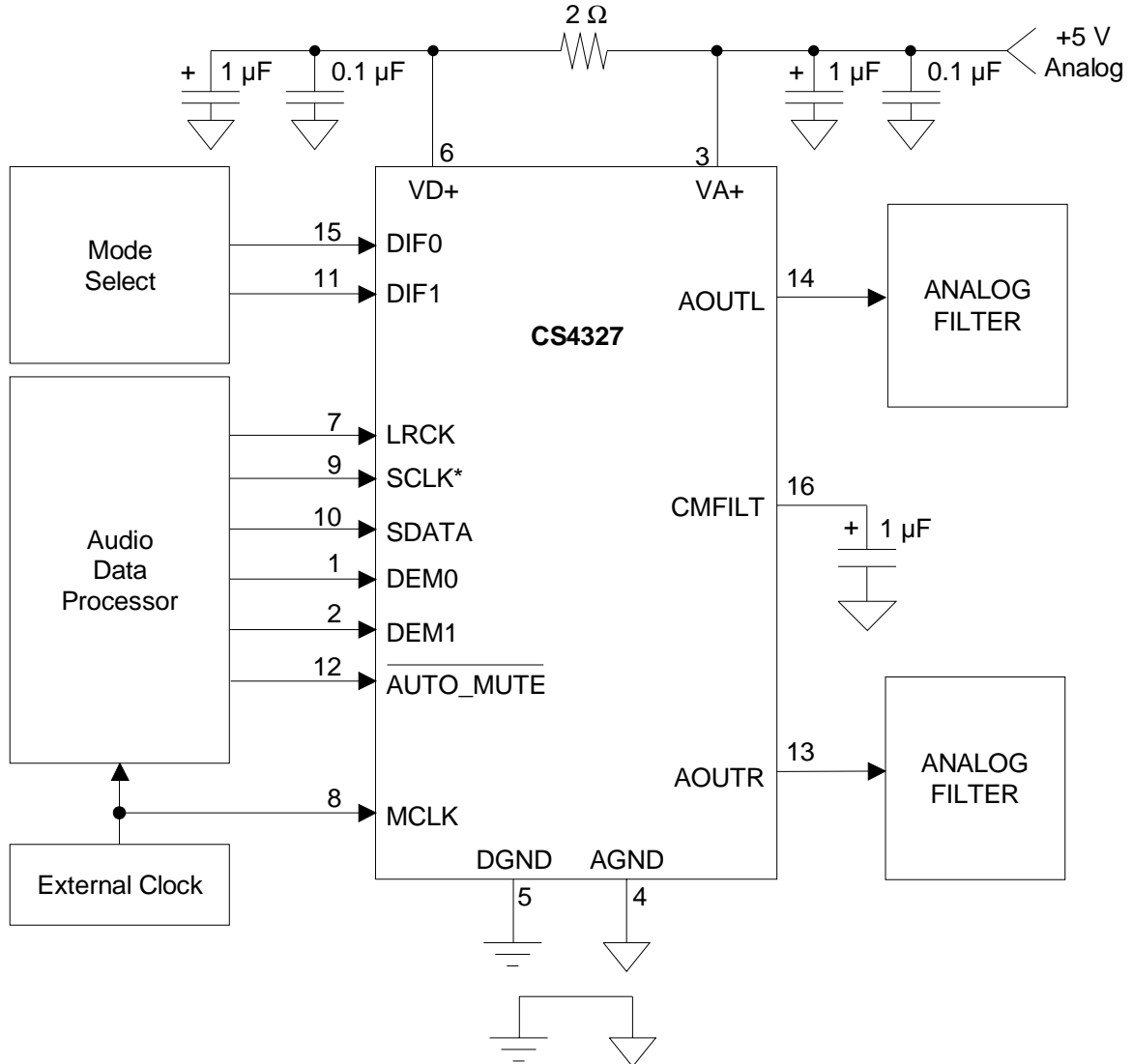

* SCLK must be connected to DGND for operation in Internal SCLK Mode

Figure 1. Typical Connection Diagram

GENERAL DESCRIPTION

The CS4327 is a complete stereo digital-to-analog system including digital interpolation, 128x fourth-order delta-sigma digital-to-analog conversion, and analog filtering, see Figure 2. This architecture provides a high insensitivity to clock jitter. The DAC converts digital data at any input sample rate between 1 and 50 kHz, including the standard audio rates of 48, 44.1 and 32 kHz.

The primary purpose of using delta-sigma modulation techniques is to avoid the limitations of laser trimmed resistive DAC architectures by using an inherently linear 1-bit DAC. The advantages of a 1-bit DAC include: ideal differential linearity, no distortion mechanisms due to resistor matching errors and no linearity drift over time and temperature due to variations in resistor values.

Digital Interpolation Filter

The digital interpolation filter increases the sample rate by a factor of 4 and is followed by a 32x digital sample-and-hold to effectively achieve a 128x interpolation filter. This filter eliminates images of the baseband audio signal which exist at multiples of the input sample rate, F_s . This allows for the selection of a less complex analog filter based on out-of-band noise attenuation requirements rather than anti-image filtering. Following the interpolation filter, the resulting frequency spectrum has images of the input signal at multiples of 128x the input sample rate. These images are removed by the external analog filter.

Delta-Sigma Modulator

The interpolation filter is followed by a fourth-order delta-sigma modulator which converts the 24-bit interpolation filter output into 1-bit data at $128x F_s$.

Switched-Capacitor Filter

The delta-sigma modulator is followed by a digital-to-analog converter which translates the 1-bit data into a series of charge packets. The magnitude of the charge in each packet is determined by sampling of a voltage reference onto a switched capacitor, where the polarity of each packet is controlled by the 1-bit signal. This technique greatly reduces the sensitivity to clock jitter and is a major improvement over earlier generations of 1-bit digital-to-analog converters where the magnitude of charge in the D-to-A process is determined by switching a current reference for a period of time defined by the master clock.

SYSTEM DESIGN

Master Clock

The Master Clock, MCLK, is used to operate the digital interpolation filter and the delta-sigma modulator. MCLK must be either 256x, 384x or 512x the desired Input Sample Rate, F_s . F_s is the frequency at which digital audio samples for each channel are input to the DAC and is equal to the LRCK frequency. The MCLK to LRCK frequency ratio is detected automatically during the initialization sequence by counting the number of MCLK

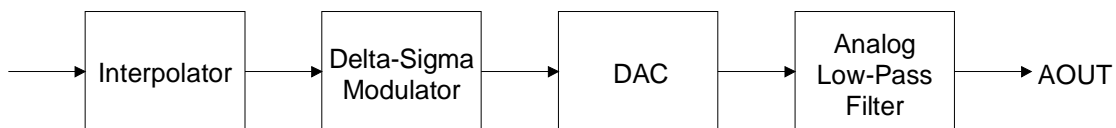

Figure 2. Block Diagram

transitions during a single LRCK period. Internal dividers are then set to generate the proper clocks for the digital filter, delta-sigma modulator and switched-capacitor filter. Once the MCLK to LRCK frequency ratio has been detected, the phase and frequency relationship between the two clocks must remain fixed. If during any LRCK this relationship is changed, the CS4327 will reset. Table 1 illustrates the standard audio sample rates and the required MCLK frequencies.

Fs (kHz)	MCLK (MHz)		
	256x	384x	512x
32	8.1920	12.2880	16.3840
44.1	11.2896	16.9344	22.5792
48	12.2880	18.4320	24.5760

Table 1. Common Clock Frequencies

Serial Data Interface

The serial data interface is accomplished via the serial data input, SDATA, serial data clock, SCLK, and the left/right clock, LRCK. The CS4327 supports four serial data formats which are selected via the digital input format pins DIF0 and DIF1. The different formats control the relationship of LRCK to the serial data and the edge of SCLK used to latch the data into the input buffer. Table 2 lists the formats, along with the associated figure number. The serial data is represented in 2's-complement format with the MSB-first in all four formats.

DIF1	DIF0	Format	Figure
0	0	0	3
0	1	1	3
1	0	2	4
1	1	3	5

Table 2. Digital Input Formats

Formats 0 and 1 are shown in Figure 3. The audio data is right-justified, LSB aligned with the trailing edge of LRCK, and latched into the serial input data buffer on the rising edge of SCLK. Formats 0 and 1 are 16 and 20-bit versions and differ only in the number of data bits required.

Format 2 is 20-bit left justified, MSB aligned with the leading edge of LRCK. Data is latched on the falling edge of SCLK. The format will support 16 and 18-bit inputs if the data is followed by four or two zeros to simulate a 20-bit input as shown in Figure 4. A very small offset will result if the 18 or 16-bit data is followed by static non-zero data.

Format 3 is compatible with the I²S serial data protocol as shown in Figure 5. Notice that the MSB is delayed 1 period of SCLK following the leading edge of LRCK and LRCK is inverted compared to the previous formats. Data is latched on the rising edge of SCLK. Format 3 is a 20-bit I²S format. 18-bit or 16-bit I²S can be implemented if the data is followed by two or four zeros to simulate a 20-bit input as shown in Figure 5. A very small offset will result if the 18 or 16-bit data is followed by static non-zero data.

Serial Clock

The serial clock controls the shifting of data into the input data buffers. The CS4327 supports both external and internal serial clock generation modes.

External Serial Clock

The CS4327 will enter the external serial clock mode if 15 or more high/low transitions are detected on the SCLK pin during any phase of the LRCK period. When this mode is enabled, internal serial clock mode cannot be accessed without returning to the power down mode.

Internal Serial Clock

In the Internal Serial Clock Mode, the serial clock is internally derived and synchronous with MCLK. The internal SCLK / LRCK ratio is always 64 and operation in this mode is identical to operation with an external serial clock synchronized with LRCK. The SCLK pin must be connected to DGND for proper operation.

The internal serial clock mode is advantageous in that there are situations where improper serial

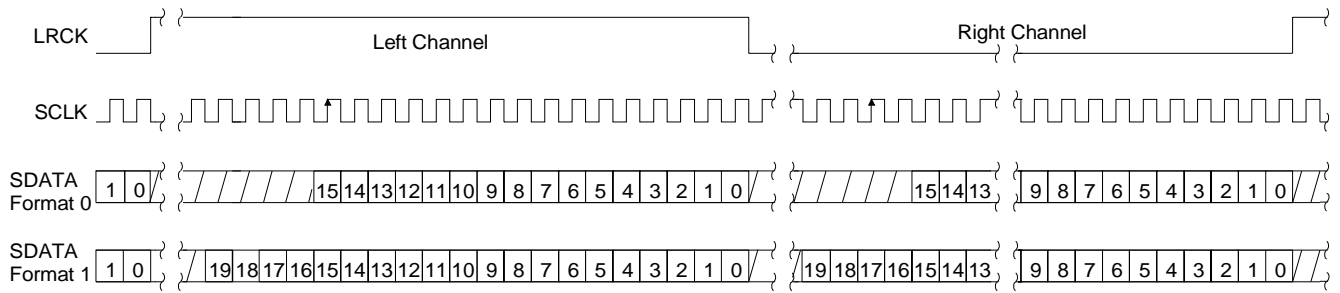

Figure 3. Digital Input Format 0 and 1.

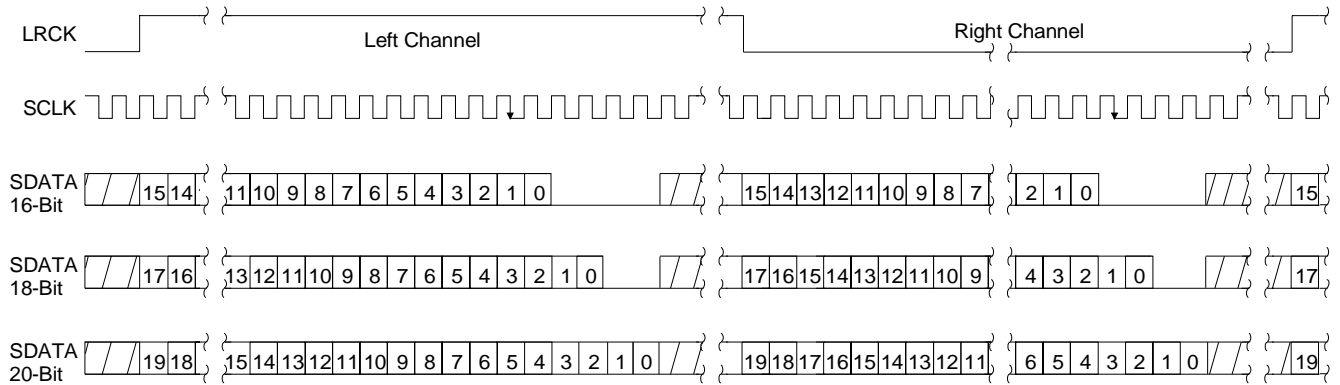

Figure 4. Digital Input Format 2.

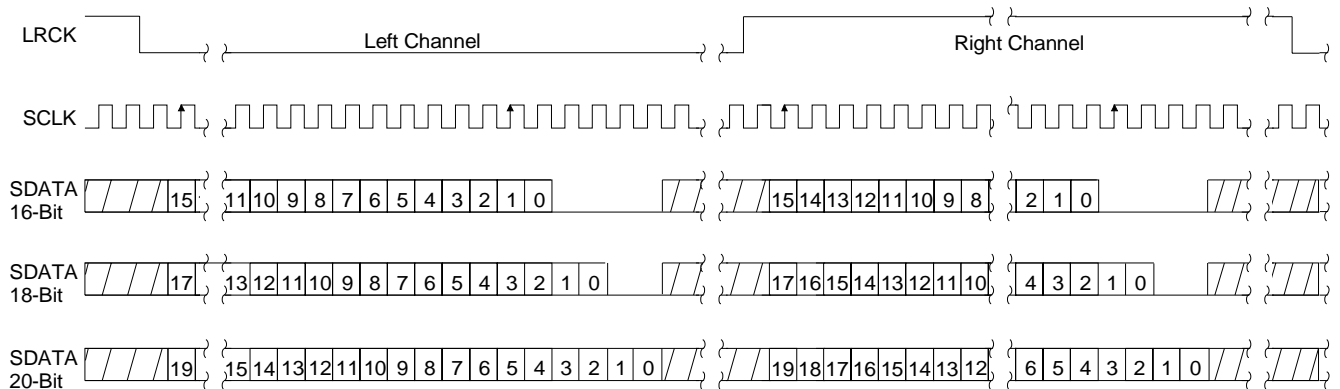

Figure 5. Digital Input Format 3.

clock routing on the printed circuit board can degrade system performance. The use of the internal serial clock mode simplifies the routing of the printed circuit board by allowing the serial clock trace to be deleted and avoids possible interference effects.

Auto Mute

An auto-mute function is useful for applications, such as compact disk players, where the idle channel noise must be minimized. The CS4327 will automatically initiate a mute for an idle channel input, where idle channel is defined as an input of static 1's or static 0's during 8192 consecutive LRCK cycles. The mute will be immediately released when non-idle channel data is applied to either the Left or Right channels. This feature is selectable and active only if the $\overline{\text{AUTO_MUTE}}$ pin is low.

De-Emphasis

Implementation of digital de-emphasis requires re-configuration of the digital filter to maintain the filter response shown in Figure 6 at multiple sample rates. The CS4327 is capable of digital de-emphasis for 32, 44.1 or 48 kHz sample rates. Table 3 shows the de-emphasis control inputs for DEM 0 and DEM 1.

DEM1	DEM0	De-emphasis
0	0	32 kHz
0	1	44.1 kHz
1	0	48 kHz
1	1	OFF

Table 3. De-Emphasis Filter Selection

Initialization, Calibration and Power-Down

Upon initial power-up, the DAC enters the power-down mode. The interpolation filters and delta-sigma modulators are reset, and the internal voltage reference, one-bit D/A converters and switched-capacitor low-pass filters are powered down. The device will remain in the power-down mode until MCLK and LRCK are presented. Once MCLK and LRCK are detected, MCLK occurrences are counted over one LRCK period to determine the MCLK / LRCK frequency ratio. Power is applied to the internal voltage reference, the D/A converters, switched-capacitor filters and the DAC will begin a common mode bias voltage calibration. This initialization and calibration sequence requires approximately 2700 cycles of LRCK. The CS4327 will enter the power-down mode, within 1 period of LRCK, if either MCLK or LRCK is removed. The initialization sequence, as described above, occurs when MCLK and LRCK are restored.

An offset calibration can be invoked by changing the state of Digital Input Format pins, DIF0 and/or DIF1, for at least 3 LRCK cycle. During calibration, a common-mode voltage of approximately 1.8 V appears at the outputs, with approximately a 16 kohm output impedance. Following calibration, the analog output impedance becomes less than 10 ohms and the common mode voltage will move to approximately 2.3 V.

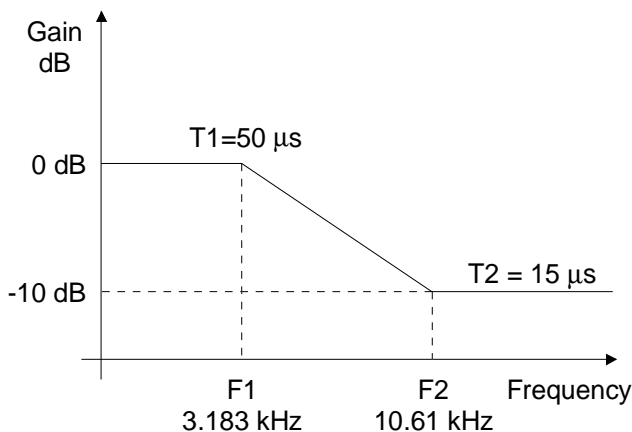

Figure 6. De-emphasis Filter Response

Combined Digital and Analog Filter Response

The frequency response of the combined analog switched-capacitor and digital filters is shown in Figures 7, 8, and 9. The overall response is clock

dependent and will scale with F_s . Note that the response plots have been normalized to F_s and can be de-normalized by multiplying the X-axis scale by F_s , such as 48 kHz.

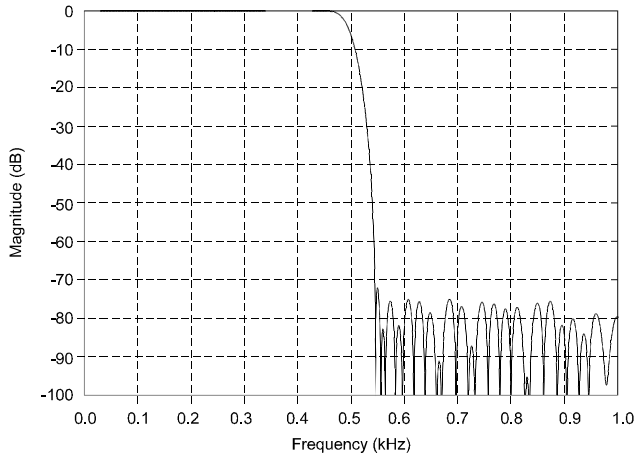

Figure 7. CS4327 Combined Digital and Analog Filter Stopband Rejection

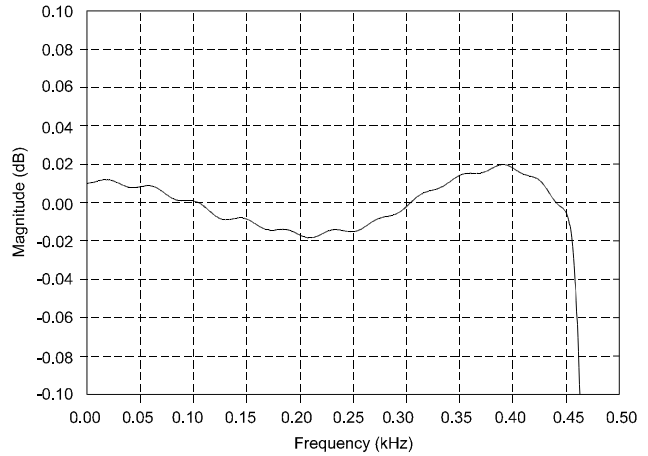

Figure 8. CS4327 Combined digital and Analog Filter Passband Response

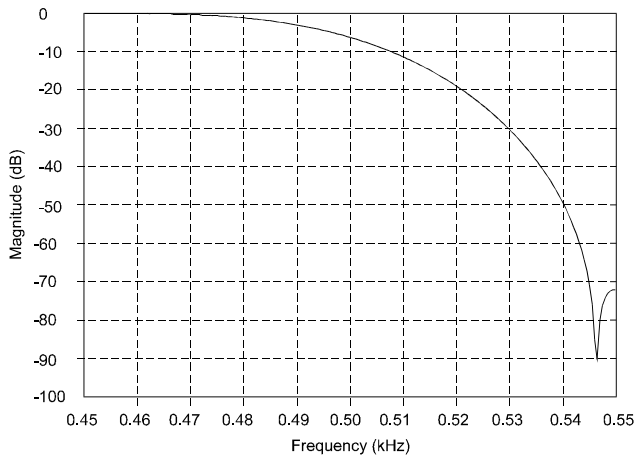

Figure 9. CS4327 Combined Digital and Analog Filter Transition Band

Analog Output and Filtering

The CS4327 contains an on-chip buffer amplifier producing single-ended outputs. Each output will produce a nominal 2.83 Vpp (1 Vrms) output with a 2.3 volt common mode for a full scale digital input.

The CS4327 filter is a linear phase design and does not include phase or amplitude compensation for an external filter. Therefore, the DAC system phase and amplitude response will be dependent on the

external analog circuitry. The second-order low-pass filter with a -3 dB frequency of 50 kHz shown in Figure 10 will give good results in most applications. The design of this filter is discussed in AN55, the Crystal Applications Note "Design Notes for a 2-pole Filter." Figure 11 displays the the output spectrum of the CS4327. Figure 12 displays the output spectrum following the 2-pole filter. Notice the attenuation beyond 50 kHz.

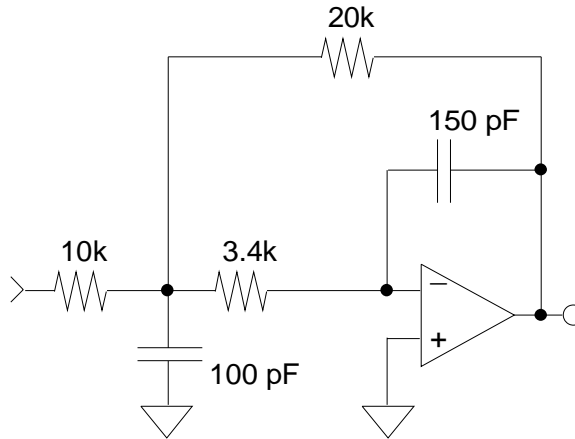

Figure 10. 2-pole Butterworth Filter

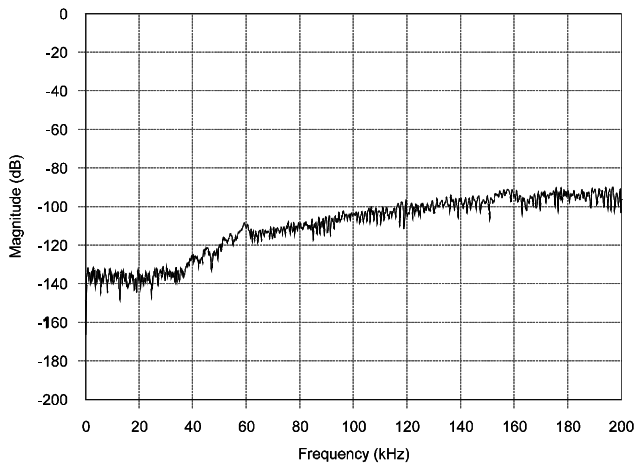

Figure 11. CS4327 Output Spectrum
Fs = 48 kHz

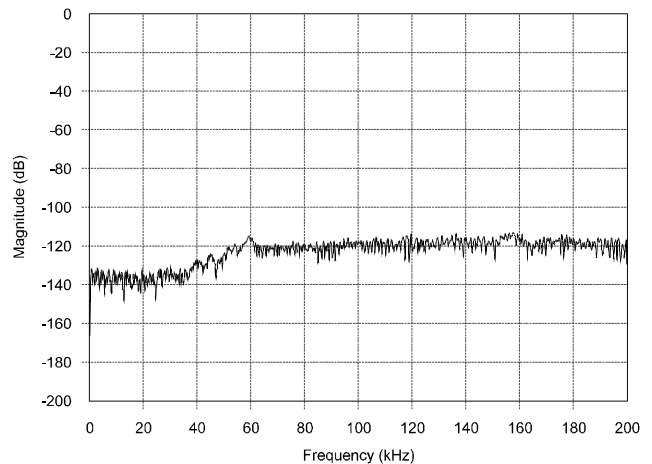

Figure 12. 2-pole Filtered Output Spectrum
Fs = 48 kHz

Grounding and Power Supply Decoupling

As with any high resolution converter, the CS4327 requires careful attention to power supply and grounding arrangements to optimize performance. Figure 1 shows the recommended power arrangements with VA+ connected to a clean +5 volt supply. VD+ should be derived from VA+ through a 2 ohm resistor. VD+ should not be used to power additional digital circuitry. All mode pins which require VD+ should be connected to pin 6 of the CS4327. All mode pins which require DGND should be connected to pin 5 of the CS4327. Pins 4 and 5, AGND and DGND, should be connected together at the CS4327. DGND for the CS4327 should not be confused with the ground for the digital section of the system. The CS4327 should be positioned over the analog ground plane near the digital / analog ground plane split. The analog and digital ground planes must be connected elsewhere in the system. The CS4327 evaluation board, CDB4327, demonstrates this layout technique. This technique minimizes digital noise and insures proper power supply matching and sequencing. Decoupling capacitors should be located as near to the CS4327 as possible.

Performance Plots

The following collection of CS4327 measurement plots were taken from the CDB4327 evaluation board using the Audio Precision Dual Domain System One.

Figure 13 shows the frequency response at a 48 kHz sample rate. The response is flat to 20 kHz ± 0.1 dB as specified.

Figure 14 shows THD+N versus signal amplitude for a 1 kHz 20-bit dithered input signal. Notice that there is no increase in distortion as the signal level decreases. This indicates very good low-level

linearity, one of the key benefits of delta-sigma digital to analog conversion.

Figure 15 shows a 16k FFT of a 1 kHz full-scale input signal. The signal has been filtered by a notch filter within the System One to remove the fundamental component of the signal. This minimizes the distortion created in the analyzer analog-to-digital converter. This technique is discussed by Audio Precision in the 10th anniversary addition of AUDIO.TST.

Figure 16 shows a 16k FFT of a 1 kHz -20 dBFS input signal. The signal has been filtered by a notch filter within the System One to remove the fundamental component of the signal.

Figure 17 shows a 16k FFT of a 1 kHz -60 dBFS input signal.

Figure 18 shows the fade-to-noise linearity. The input signal is a dithered 20-bit 500 Hz sine wave which fades from -60 to -120 dBFS. During the fade, the output from the CS4327 is measured and compared to the ideal level. Notice the very close tracking of the output level to the ideal, even at low level inputs. The gradual shift of the plot away from zero at signals levels < -110 dB is caused by the background noise starting to dominate the measurement.

Schematic & Layout Review Service

**Confirm Optimum
Schematic & Layout
Before Building Your Board.**

**For Our Free Review Service
Call Applications Engineering.**



C a l l : (5 1 2) 4 4 5 - 7 2 2 2

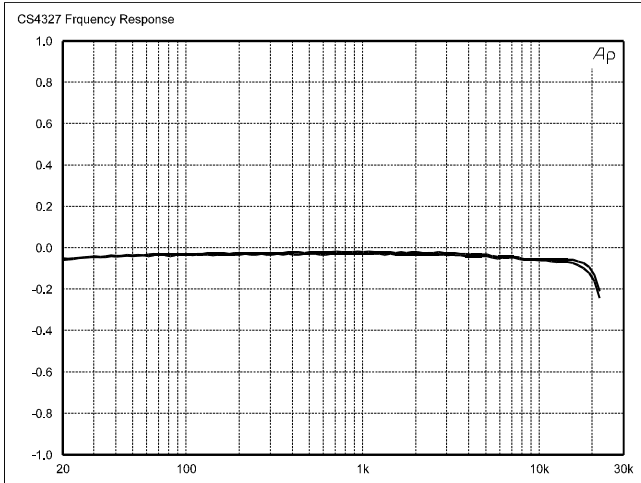

Figure 13. Frequency Response

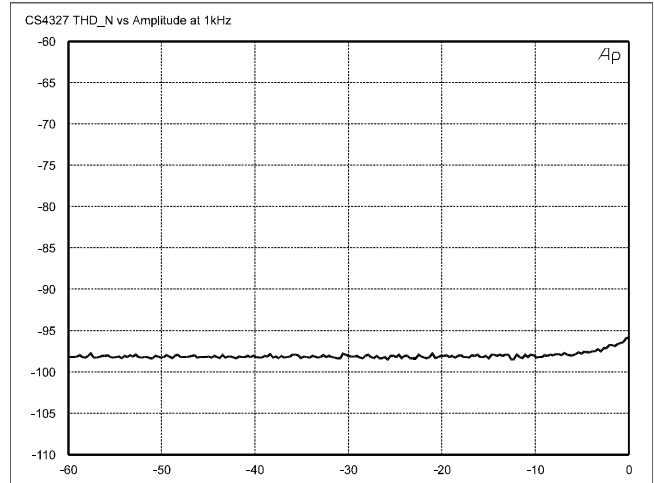

Figure 14. THD+N vs. Amplitude

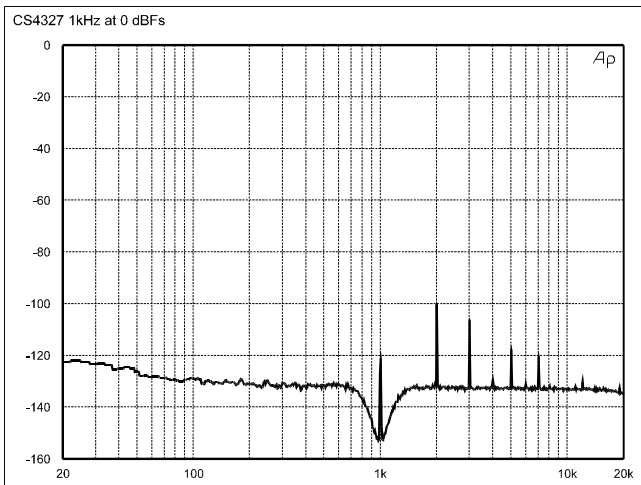

Figure 15. 0 dBFS FFT

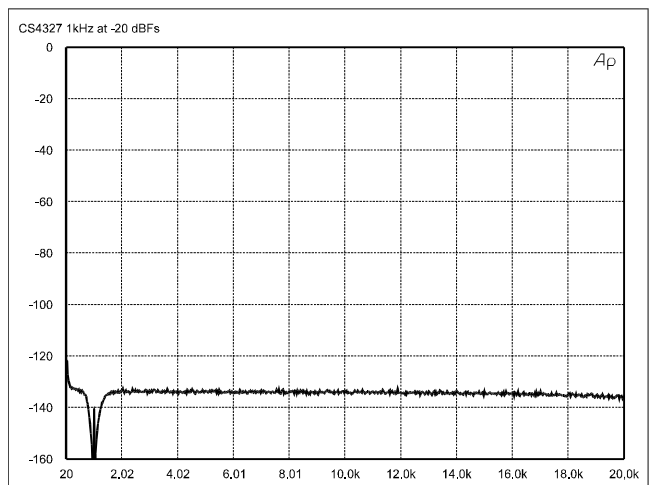

Figure 16. -20 dBFS FFT

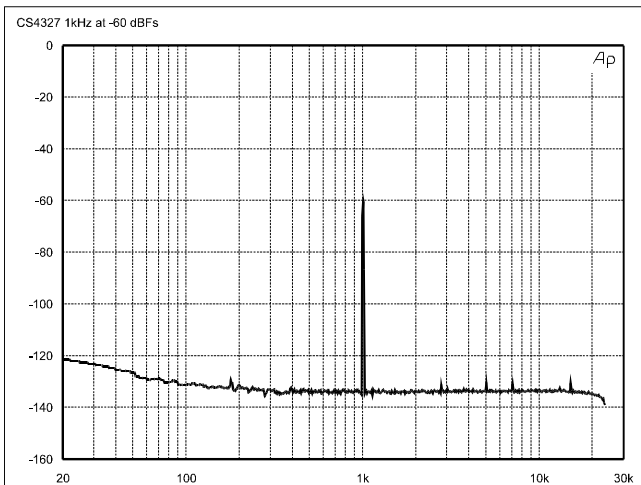

Figure 17. -60 dBFS FFT

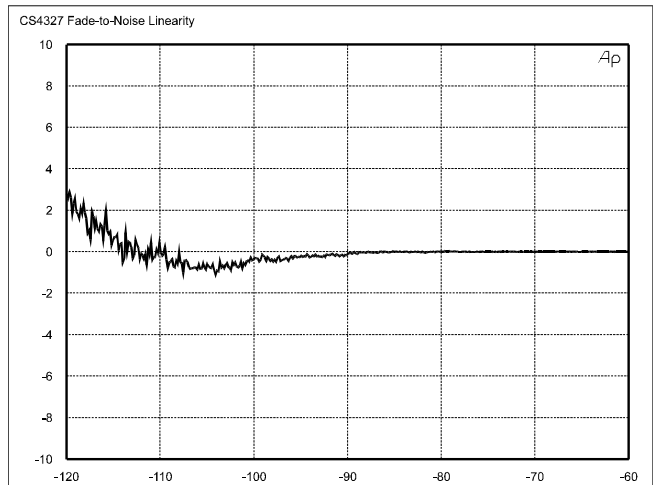

Figure 18. Fade-to-Noise Linearity

PIN DESCRIPTIONS

DEM0	1 •	16	CMFILT
DEM1	2	15	DIF0
VA+	3	14	AOUTL
AGND	4	13	AOUTR
DGND	5	12	AUTO_MUTE
VD+	6	11	DIF1
LRCK	7	10	SDATA
MCLK	8	9	SCLK

*Power Supply Connections***VA+ - Positive Analog Power, PIN 3.**

Positive analog supply. Nominally +5 volts.

VD+ - Positive Digital Power, PIN 6.

Positive supply for the digital section. Nominally +5 volts.

AGND - Analog Ground, PIN 4.

Analog ground reference.

DGND - Digital Ground, PIN 5.

Ground for the digital section.

*Analog Outputs***AOUTR - Right Channel Analog Output, PIN 13.**

Analog output connection for the Right channel output. Nominally 1 Vrms for full-scale digital input signal.

AOUTL - Left Channel Analog Output, PIN 14.

Analog output connection for the Left channel outputs. Nominally 1 Vrms for full-scale digital input signal.

Digital Inputs

MCLK - Clock Input, PIN 8.

The frequency must be either 256x, 384x or 512x the input sample rate (Fs).

LRCK - Left/Right Clock, PIN 7.

This input determines which channel is currently being input on the Serial Data Input pin, SDATA. The format of LRCK is controlled by DIF0 and DIF1.

SCLK - Serial Bit Input Clock, PIN 9.

Clocks the individual bits of the serial data in from the SDATA pin. The edge used to latch SDATA is controlled by DIF0 and DIF1.

SDATA - Serial Data Input, PIN 10.

Two's complement MSB-first serial data of either 16, 18 or 20 bits is input on this pin. The data is clocked into the CS4327 via the SCLK clock, and the channel is determined by the LRCK clock. The format for the previous two clocks is determined by the Digital Input Format pins, DIF0 and DIF1.

DIF0, DIF1 - Digital Input Format, PINS 15, 11

These two pins select one of four formats for the incoming serial data stream. These pins set the format of the SCLK and LRCK clocks with respect to SDATA. The formats are listed in Table 2.

DEM0, DEM1 - De-Emphasis Select, PINS 1, 2.

Controls the activation of the standard 50/15 μ s de-emphasis filter for either 32, 44.1 or 48 kHz sample rates.

AUTO_MUTE - Automatic Mute on Idle Channel Input, PIN 12.

When AUTO_MUTE is low the analog outputs are muted following an idle channel detection. Idle channel is defined as an input of static 1's or static 0's during 8192 consecutive LRCK cycles. Mute is canceled with the return of active channel input data.

CMFILT - Common Mode Filter, PIN 16

Used to filter the common mode output voltage with a 1 μ F capacitor. This pin is not intended to supply any current and should not be used for the generation of an external bias voltage.

PARAMETER DEFINITIONS

Dynamic Range

The ratio of the full scale rms value of the signal to the rms sum of all other spectral components over the specified bandwidth. Dynamic range is a signal-to-noise measurement over the specified bandwidth made with a -60 dBFS signal. 60 dB is then added to the resulting measurement to refer the measurement to full scale. This technique ensures that the distortion components are below the noise level and do not effect the measurement. This measurement technique has been accepted by the Audio Engineering Society, AES17-1991, and the Electronic Industries Association of Japan, EIAJ CP-307.

Total Harmonic Distortion + Noise

The ratio of the rms value of the signal to the rms sum of all other spectral components over the specified bandwidth (typically 10 Hz to 20 kHz), including distortion components. Expressed in decibels.

Idle Channel Noise / Signal-to-Noise-Ratio

The ratio of the rms analog output level with 1 kHz full scale digital input to the rms analog output level with all zeros into the digital input. Measured A-weighted over a 10 Hz to 20 kHz bandwidth. Units in decibels. This specification has been standardized by the Audio Engineering Society, AES17-1991, and referred to as Idle Channel Noise. This specification has also been standardized by the Electronic Industries Association of Japan, EIAJ CP-307, and referred to as Signal-to-Noise-Ratio.

Interchannel Isolation

A measure of crosstalk between the left and right channels. Measured for each channel at the converter's output with all zeros to the input under test and a full-scale signal applied to the other channel. Units in decibels.

Frequency Response

A measure of the amplitude response variation from 10 Hz to 20 kHz relative to the amplitude response at 1 kHz. Units in decibels.

De-Emphasis Error

A measure of the difference between the ideal de-emphasis filter and the actual de-emphasis filter response. Measured from 10 Hz to 20 kHz. Units in decibels.

Interchannel Gain Mismatch

The gain difference between left and right channels. Units in decibels.

Gain Error

The deviation from the nominal full scale analog output for a full scale digital input.

Gain Drift

The change in gain value with temperature. Units in ppm/°C.

PACKAGE DIMENSIONS

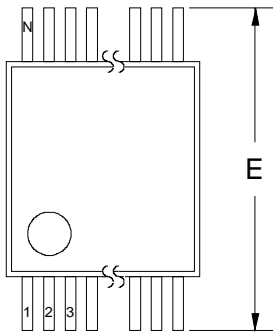

TOP VIEW

SSOP Package Dimensions

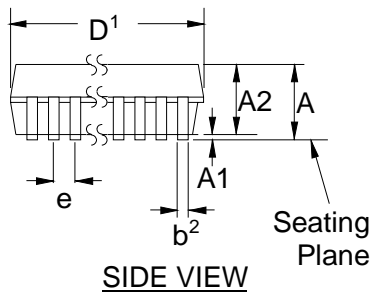

SIDE VIEW

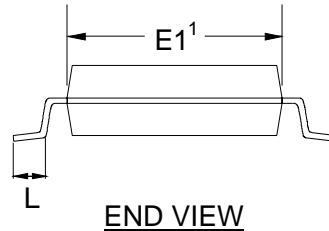

END VIEW

NOTES:

1. DIMENSIONS D AND E1 ARE REFERENCE DATUMS AND DO NOT INCLUDE MOLD FLASH OR PROTRUSIONS, BUT DO INCLUDE MOLD MISMATCH AND ARE MEASURED AT THE PARTING LINE. MOLD FLASH OR PROTRUSIONS SHALL NOT EXCEED 0.20mm PER SIDE.
2. DIMENSION b DOES NOT INCLUDE DAMBAR PROTRUSION/INTRUSION. ALLOWABLE DAMBAR PROTRUSION SHALL BE 0.13mm TOTAL IN EXCESS OF b DIMENSION AT MAXIMUM MATERIAL CONDITION. DAMBAR INTRUSION SHALL NOT REDUCE DIMENSION b BY MORE THAN 0.07mm AT LEAST MATERIAL CONDITION.
3. THESE DIMENSIONS APPLY TO THE FLAT SECTION OF THE LEAD BETWEEN 0.10 AND 0.25mm FROM LEAD TIPS.

DIM	MILLIMETERS			INCHES			Note
	MIN	NOM	MAX	MIN	NOM	MAX	
A	-	-	2.13	-	-	0.084	
A1	0.05	0.15	0.25	0.002	0.006	0.010	
A2	1.62	1.75	1.88	0.064	0.070	0.074	
b	0.22	0.30	0.38	0.009	0.012	0.015	2, 3
D	see other table			see other table			1
E	7.40	7.80	8.20	0.291	0.307	0.323	
E1	5.00	5.30	5.60	0.197	0.209	0.220	1
e	0.61	0.65	0.69	0.024	0.026	0.027	
L	0.63	0.90	1.03	0.025	0.035	0.040	
N	see other table			see other table			
∞	0°	4°	8°	0°	4°	8°	

N	D			INCHES			Note
	MIN	NOM	MAX	MIN	NOM	MAX	
16	5.90	6.20	6.50	0.232	0.244	0.256	1
20	6.90	7.20	7.50	0.272	0.283	0.295	1
28	9.90	10.20	10.50	0.390	0.402	0.413	1

• **Notes** •

Evaluation Board for CS4327

Features

- Demonstrates recommended layout and grounding arrangements
- CS8412 Receives AES/EBU, S/PDIF, & EIAJ-340 Compatible Digital Audio
- Digital and Analog Patch Areas
- Requires only a digital signal source and power supplies for a complete Digital-to-Analog-Converter system

General Description

The CDB4327 evaluation board is an excellent means for quickly evaluating the CS4327 20-bit, stereo D/A converter. Evaluation requires an analog signal analyzer, a digital signal source and a power supply. Analog outputs are provided via RCA connectors for both channels.

The CS8412 digital audio receiver I.C. provides the system timing necessary to operate the CS4327 and will accept AES/EBU, S/PDIF, and EIAJ-340 compatible audio data. The evaluation board may also be configured to accept external timing signals for operation in a user application during system development.

ORDERING INFORMATION: CDB4327

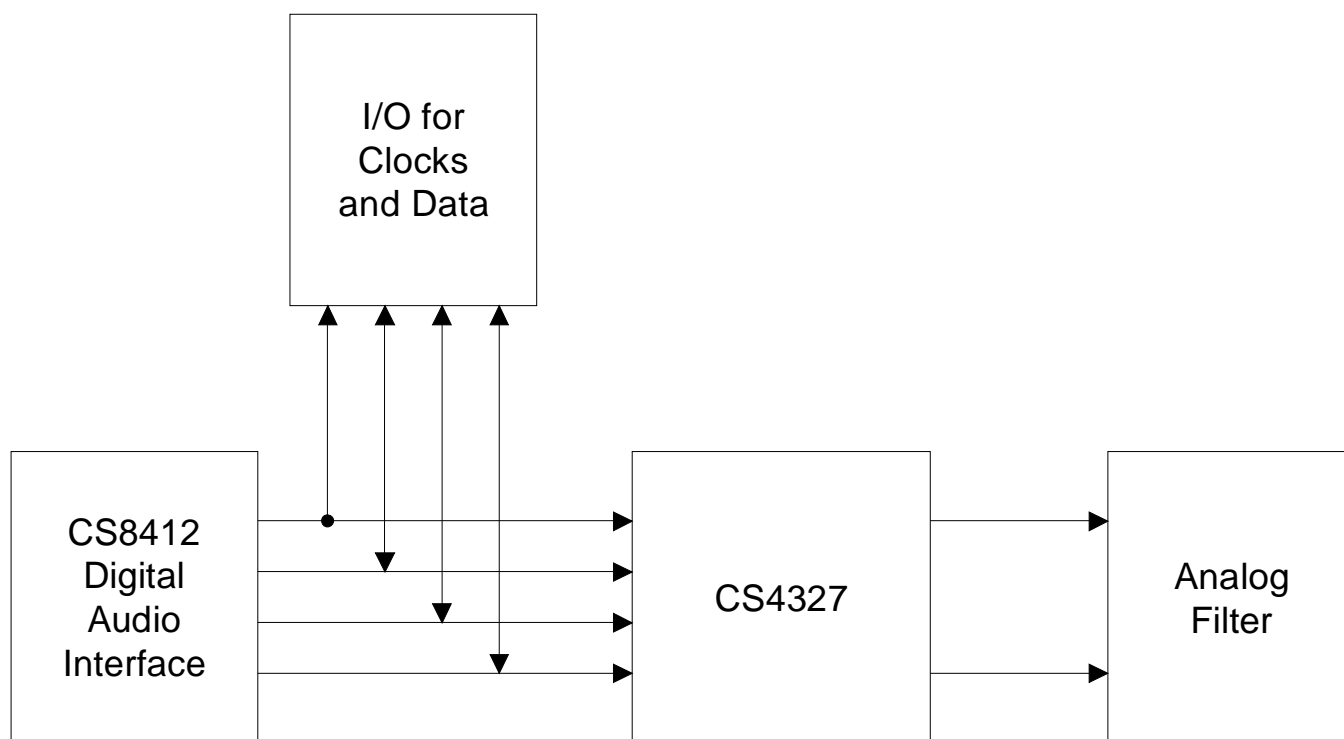

CDB4327 System Overview

The CDB4327 evaluation board is an excellent means of quickly evaluating the CS4327. The CS8412 digital audio interface receiver provides an easy interface to digital audio signal sources including the majority of digital audio test equipment. The evaluation board also allows the user to supply clocks and data through a 10-pin header for system development.

The CDB4327 schematic has been partitioned into 7 schematics shown in Figures 2 through 8. Each partitioned schematic is represented in the system diagram shown in Figure 1. Notice that the the system diagram also includes the interconnections between the partitioned schematics.

CS4327 Digital to Analog Converter

A description of the CS4327 is included in the CS4327 data sheet.

CS8412 Digital Audio Receiver

The system receives and decodes the standard S/PDIF data format using a CS8412 Digital Audio Receiver, Figure 8. The outputs of the CS8412 include a serial bit clock, serial data, left-right clock (FSYNC), de-emphasis control and a 256Fs master clock. The operation of the CS8412 and a discussion of the digital audio interface are included in the 1994 *Crystal Semiconductor Audio Data Book*.

During normal operation, the CS8412 operates in the Channel Status mode where the LED's display channel status information for the channel selected by the CSLR/FCK jumper. This allows the CS8412 to decode and supply the de-emphasis bit from the digital audio interface for control of the CS4327 de-emphasis filter via pin 3, CC/F0, of the CS8412.

When the Error Information Switch is activated, the CS8412 operates in the Error and Frequency

information mode. The information displayed by the LED's can be decoded by consulting the CS8412 data sheet. If the Error Information Switch is activated, the CC/F0 output has no relation to the de-emphasis bit and it is likely that the de-emphasis control for the CS4327 will be erroneous and produce an incorrect audio output.

Encoded sample frequency information can be displayed provided a proper clock is being applied to the FCK pin of the CS8412. When an LED is lit, this indicates a "1" on the corresponding pin located on the CS8412. When an LED is off, this indicates a "0" on the corresponding pin. Neither the L or R option of CSLR/FCK should be selected if the FCK pin is being driven by a clock signal.

The evaluation board has been designed such that the input can be either optical or coax, Figure 7. It is not necessary to select the active input. However, both inputs can not be driven simultaneously.

Data Format

The CS4327 must be configured to be compatible with the incoming data and can be set with DIF0 and DIF1. The CS8412 data format can be set with the M0, M1, M2 and M3. There are several data formats which the CS8412 can produce that are compatible with CS4327. Refer to Table 2 for one possibility.

Power Supply Circuitry

Power is supplied to the evaluation board by four binding posts, Figure 9. The +5 Volt input supplies power to the CS4327 (through VA+), the CS8412 (through VA+ and VD+), and the +5 Volt digital circuitry (through VD+). The +/- 12 Volt input supplies power to the analog filter circuitry.

Input/Output for Clocks and Data

The evaluation board has been designed to allow the interface to external systems via the 10-pin header, J1. This header allows the evaluation board to accept externally generated clocks and data. The schematic for the clock/data I/O is shown in Figure 6. The 74HC243 transceiver functions as an I/O buffer where the CLK SOURCE jumper determines if the transceiver operates as a transmitter or receiver.

The transceiver operates as a transmitter with the CLK SOURCE jumper in the 8412 position. LRCK, SDATA, and SCLK from the CS8412 will be available on J1. J22 must be in the 0 position and J23 must be in the 1 position for MCLK to be an output and to avoid bus contention on MCLK.

The transceiver operates as a receiver with the CLK SOURCE jumper in the EXTERNAL position. LRCK, SDATA and SCLK on J1 become inputs. The CS8412 must be removed from the evaluation board for operation in this mode.

There are 2 options for the source of MCLK in the EXT CLK source mode. MCLK can be an input with J23 in the 1 position and J22 in the 0 position. However, the recommended mode of operation is to generate MCLK on the evaluation board. MCLK becomes an output with LRCK, SCLK and SDATA inputs. This technique insures that the CS4327 receives a jitter free clock to maximize performance. This can be accomplished by installing a crystal oscillator into U4, see Figure 8 (the socket for U4 is located within the footprint for the CS8412) and placing J22 in the 1 position and J23 in the 0 position.

Analog Filter

The design of the second-order Butterworth low-pass filter, Figure 5, is discussed in the CS4327 data sheet and the applications note "*Design Notes for a 2-pole Filter.*"

Grounding and Power Supply Decoupling

The CS4327 requires careful attention to power supply and grounding arrangements to optimize performance. Figure 2 shows the recommended power arrangements with VA+ connected to a clean +5 Volt supply. VD1+ is derived from VA+ through a 2 ohm resistor. VD1+ should not used for any additional digital circuitry.

Ideally, all mode pins which require VD1+ should be connected to pin 6 of the CS4327 and all mode pins which require DGND should connected to pin 5 of the CS4327. AGND and DGND, Pins 4 and 5, are connected together at the CS4327. The evaluation board has separate analog and digital regions with individual ground planes. DGND for the CS4327 should not be confused with the ground for the digital section of the system (GND). The CS4327 is positioned over the analog ground plane near the digital/analog ground plane split. These ground planes are connected elsewhere on the board. This layout technique is used to minimizing digital noise and to insure proper power supply matching/sequencing. The decoupling capacitors are located as close to the CS4327 as possible. Extensive use of ground plane fill on both the analog and digital sections of the evaluation board yield large reductions in radiated noise effects.

CONNECTOR	INPUT/OUTPUT	SIGNAL PRESENT
+5V	input	+5 Volts for the CS4327, CS8412, and digital section
+/- 12V	input	+/- 12 Volts for analog filter section
GND	input	ground connection from power supply
Digital input	input	digital audio interface input via coax
Optical input	input	digital audio interface input via optical
J1	input/output	I/O for system clocks and digital audio data
AOUTL	output	left channel analog output
AOUTR	output	right channel analog output

Table 1. System Connections

JUMPER	PURPOSE	POSITION	FUNCTION SELECTED
CSLR/FCK	Selects channel for CS8412 channel status information	L R	See CS8412 data sheet for details
Clock Select	Selects source of system clocks and data	*8412 EXT	CS8412 clock/data source External clock/data source
J22 J23	Selects MCLK as input or output	0 1	See <i>Input/Output for Clocks and Data</i> section of text
M0 M1 M2 M3	CS8412 mode select	*Low *Low *Low *Low	See CS8412 data sheet for details
auto_mute	CS4327 Auto Mute	*Low High	On Off
DEM0 DEM1	De-emphasis select	*High *Low	See CS4327 data sheet for details set for 44.1 kHz
DIF0 DIF1	CS4327 digital input format	*Low *High	See CS4327 data sheet for details
SCLK	CS4327 SCLK Mode	*INT EXT	Internal SCLK Mode External SCLK Mode
DEM_8412	Selects source of de-emphasis control	*Low High	CS8412 de-emphasis De-emphasis input static high

* Default setting from factory

Table 2. CDB4327 Jumper Selectable Options

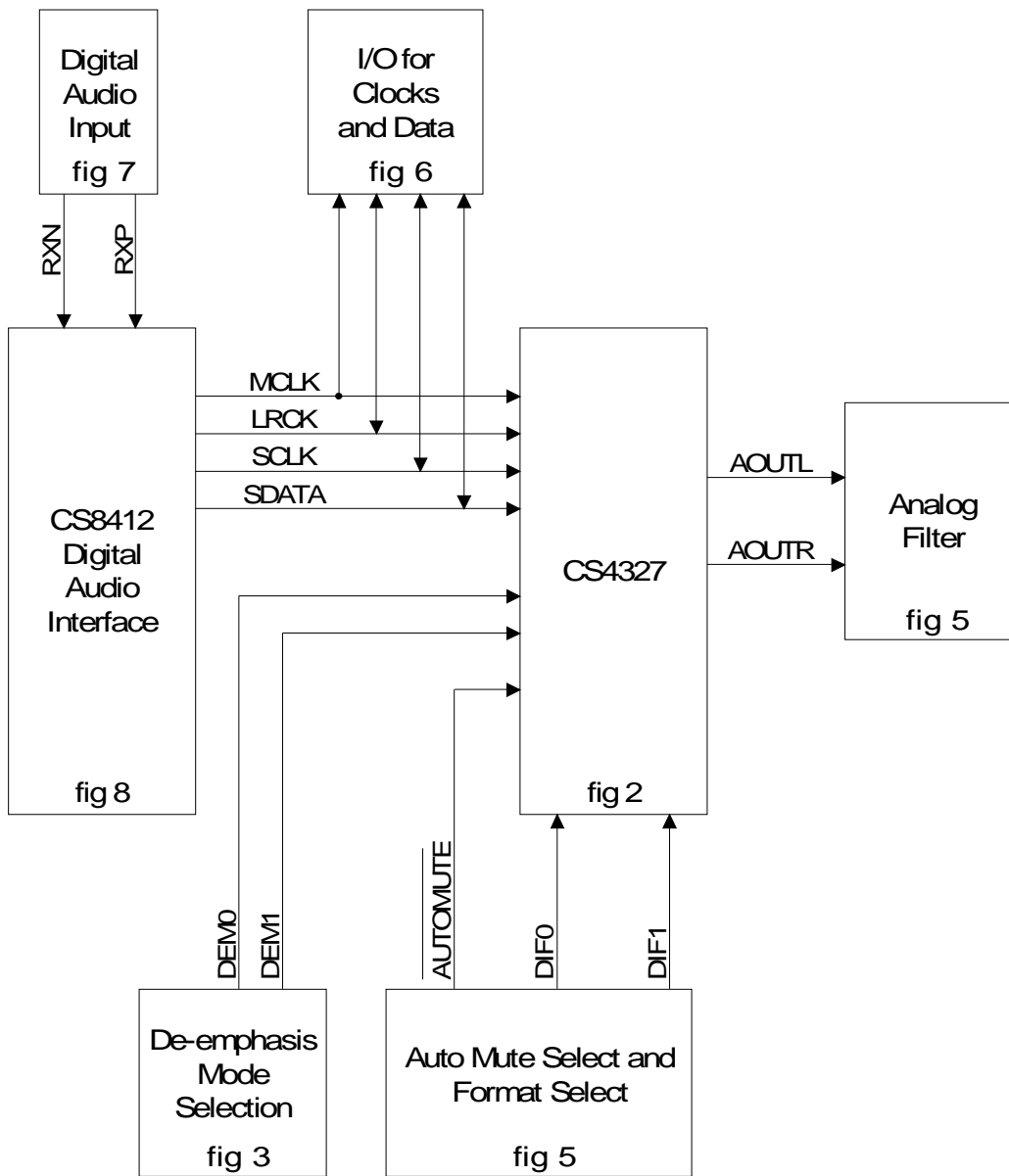

Figure 1. System Block Diagram and Signal Flow

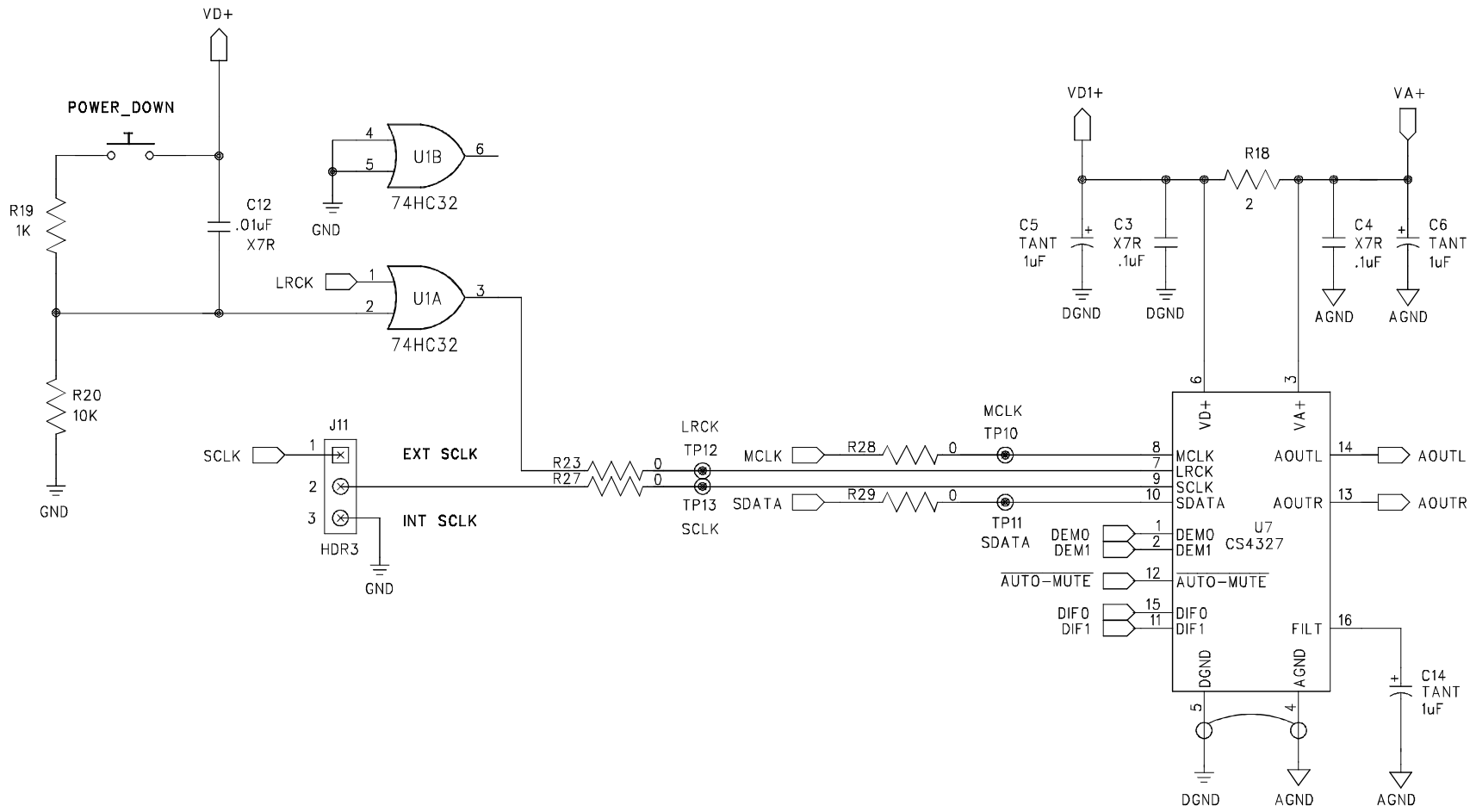

Figure 2. CS4327 and Connections

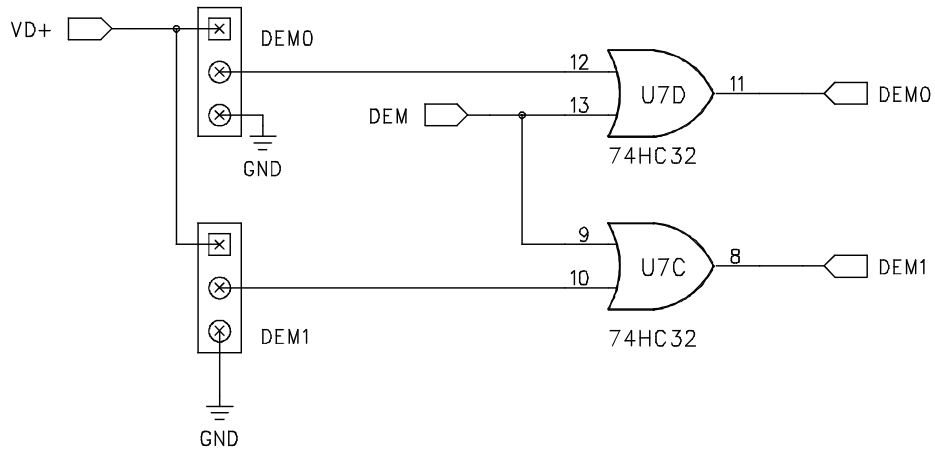

Figure 3. De-Emphasis Mode Selection

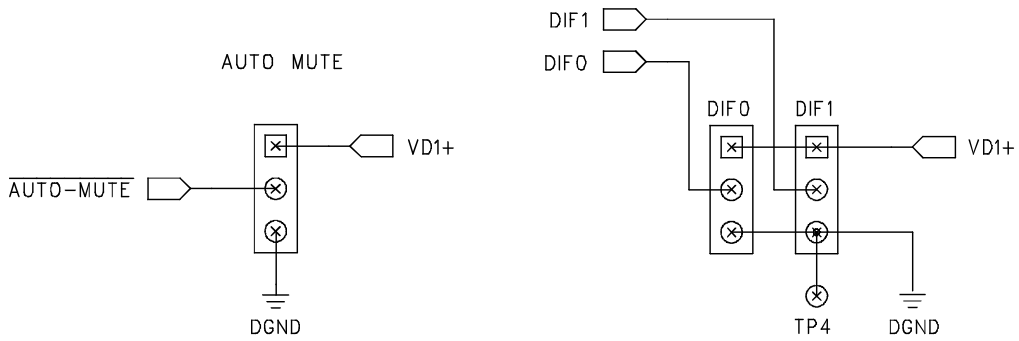
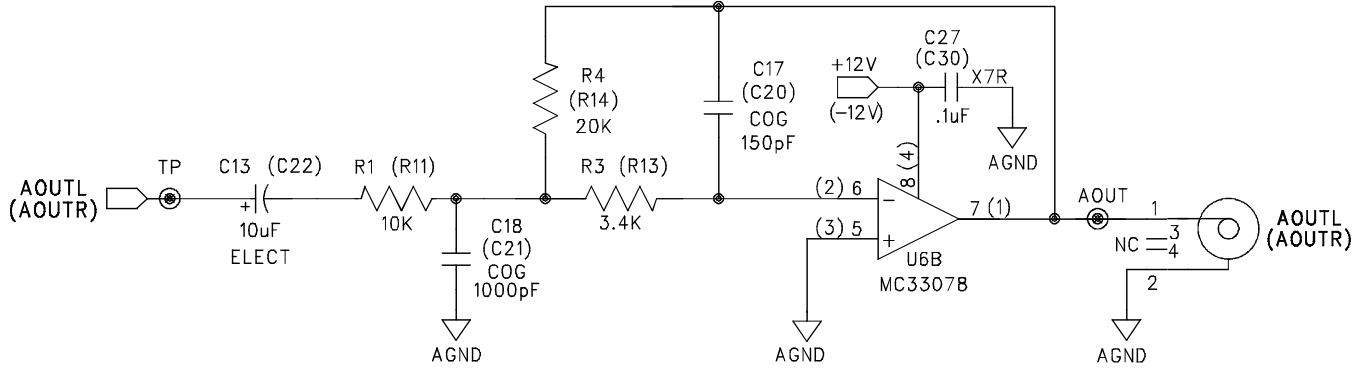

Figure 4. Auto-Mute Select and Format Select



NOTE: Right Channel components in parentheses

Figure 5. 2-Pole Analog Filter

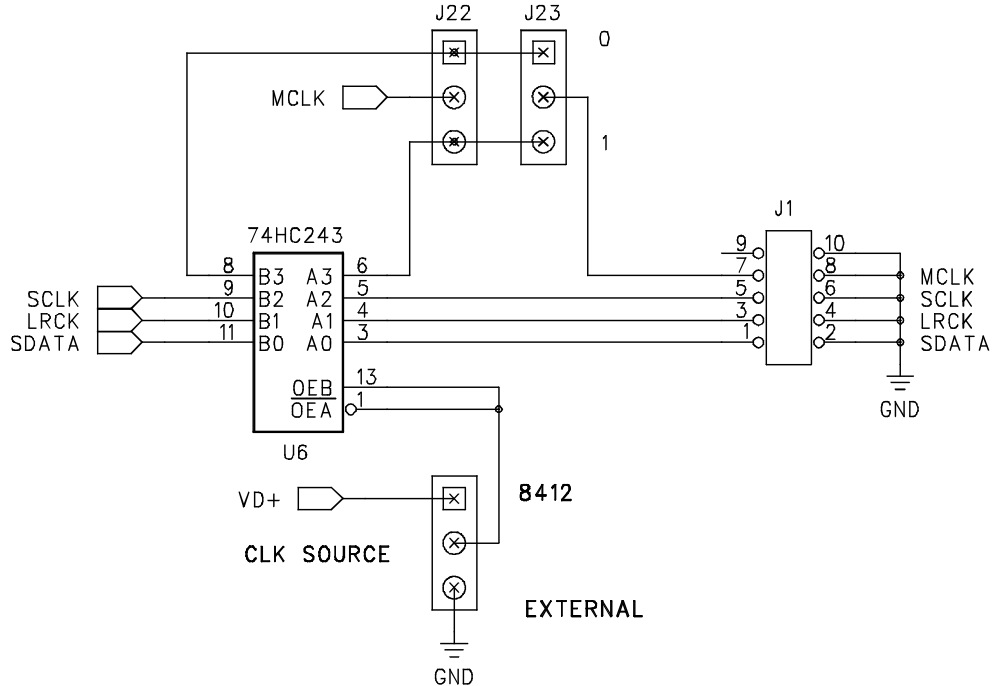
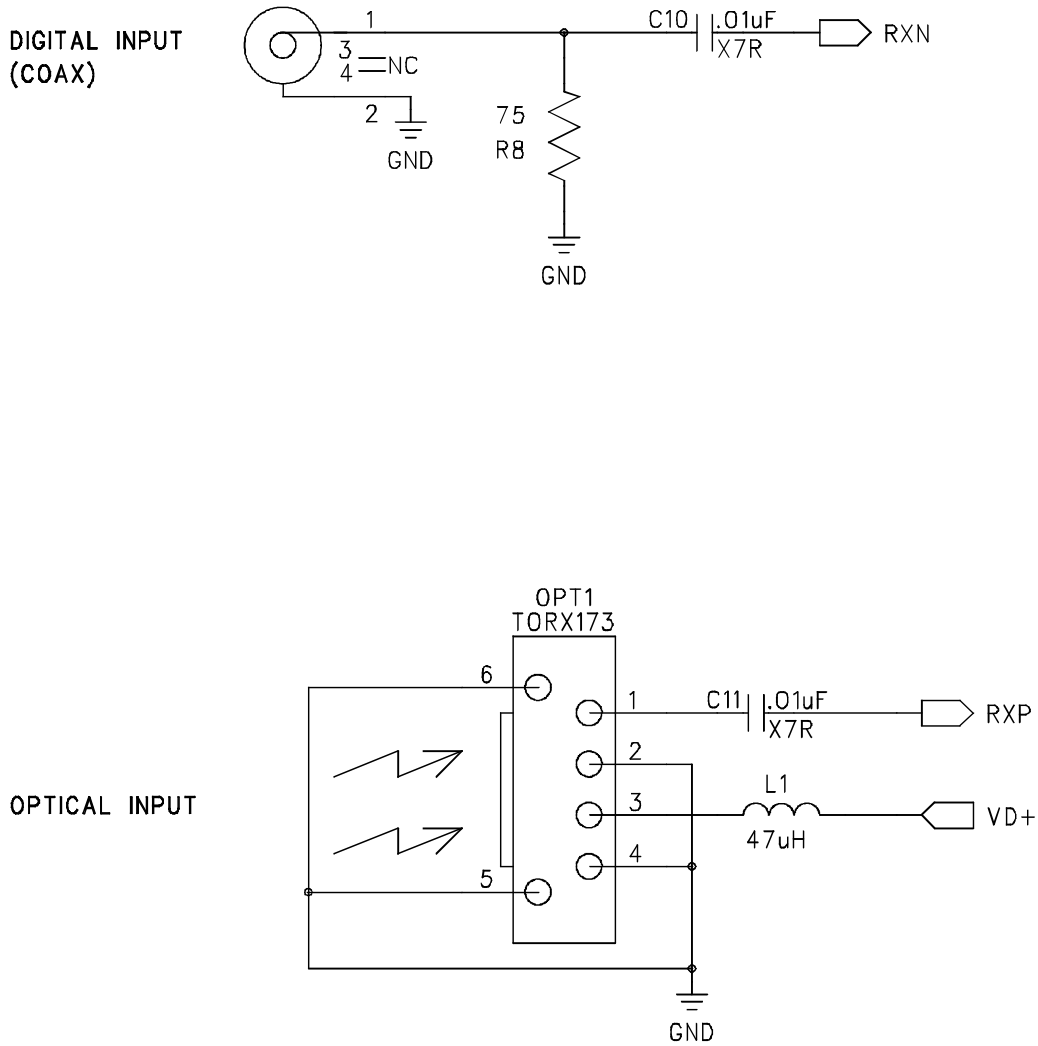
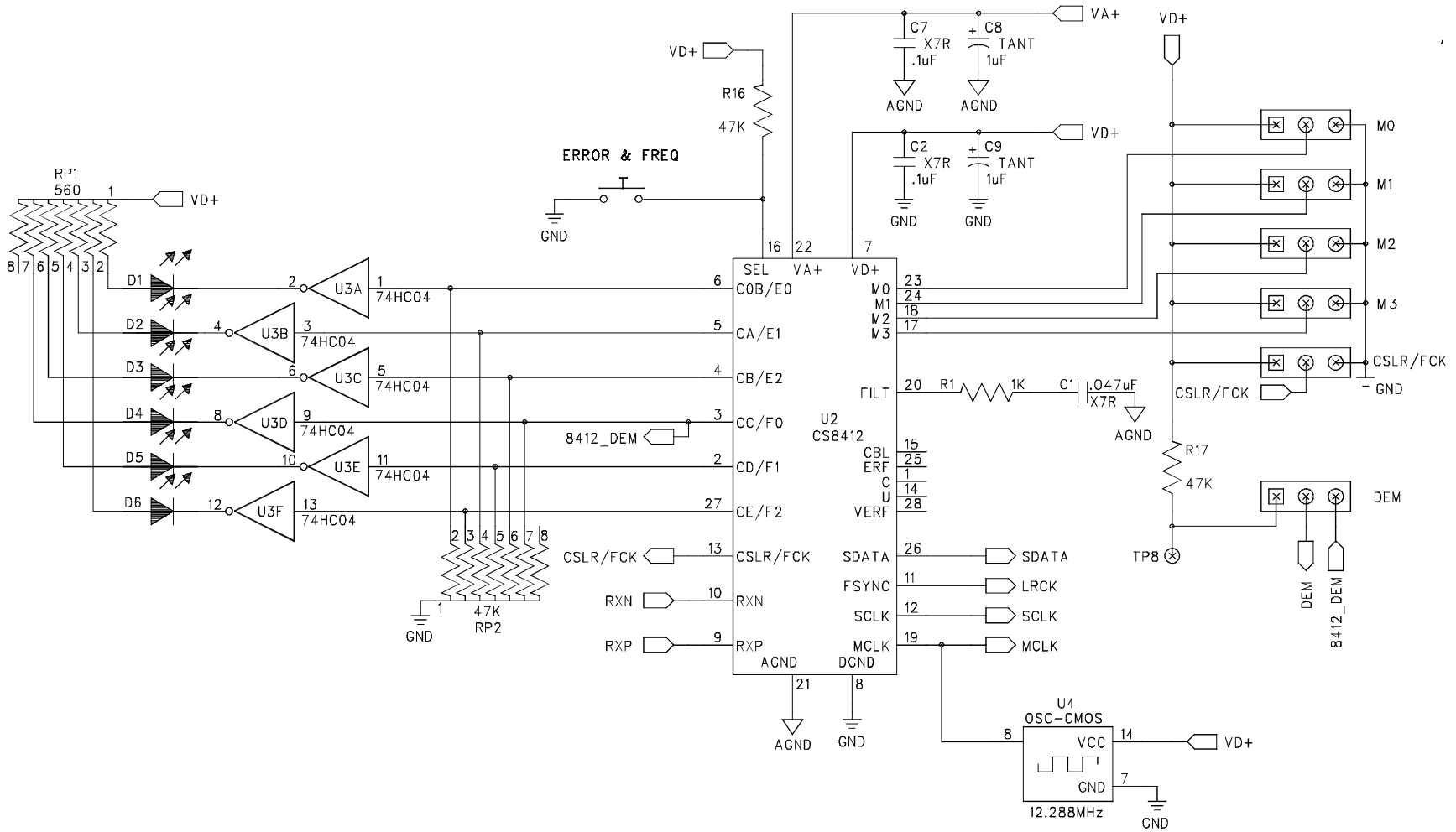

Figure 6. I/O Interface for Clocks and Data



OPT1 Toshiba TORX173 optical receiver available from Insight Electronics

Figure 7. Digital Audio Input



Note: U2 and U4 can not be installed simultaneously

Figure 8. CS8412 and Connections

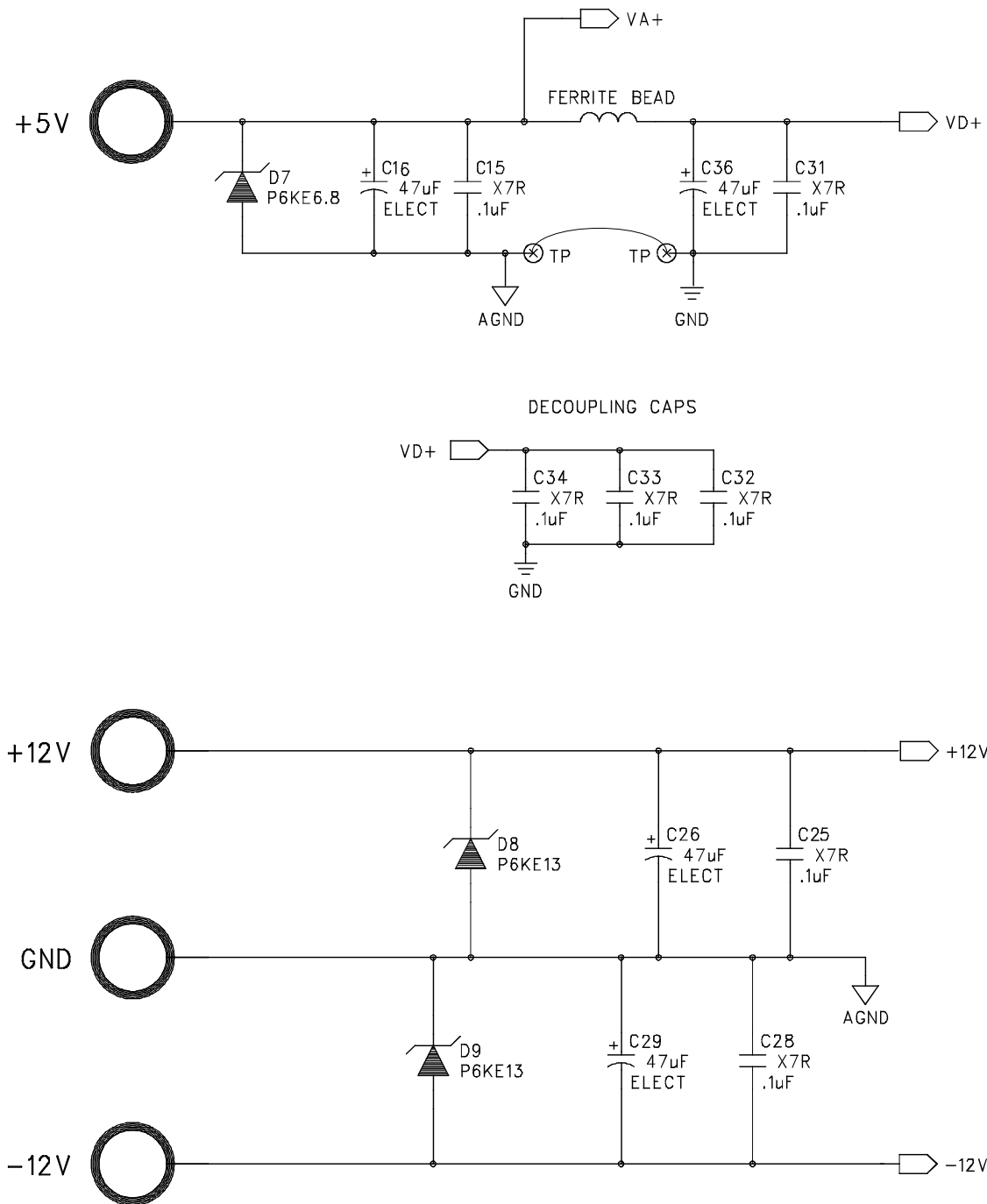
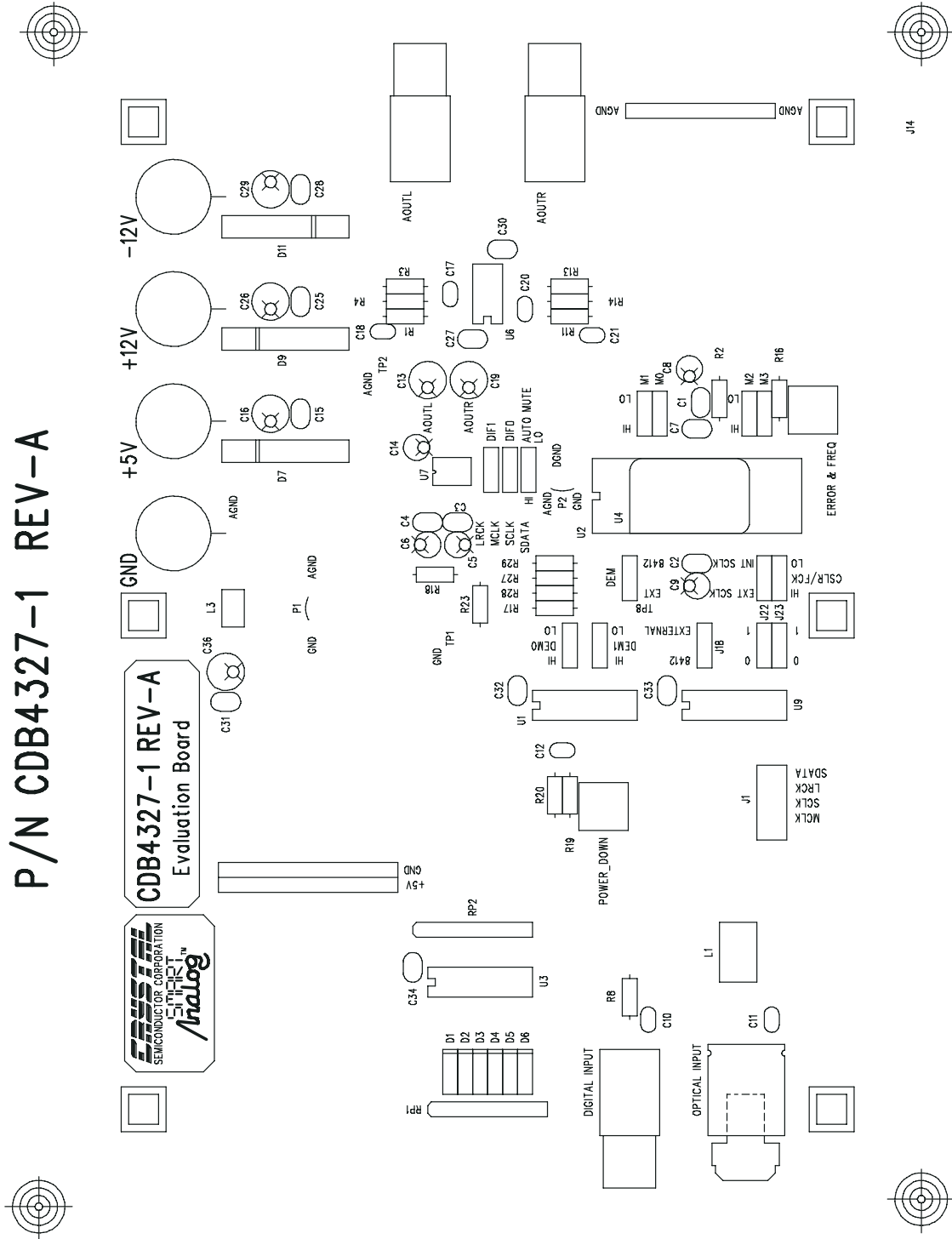

Figure 9. Power Supply Connections

CRYSTAL SEMICONDUCTOR
CS4327 (SSOP-16)
P/N CDB4327-1 REV-A



COMPONENT SIDE SILKSCREEN

Figure 10. CDB4327 Component Side Silkscreen

CRYSTAL SEMICONDUCTOR
CS4327 (SSOP-16)
P/N CDB4327-1 REV-A

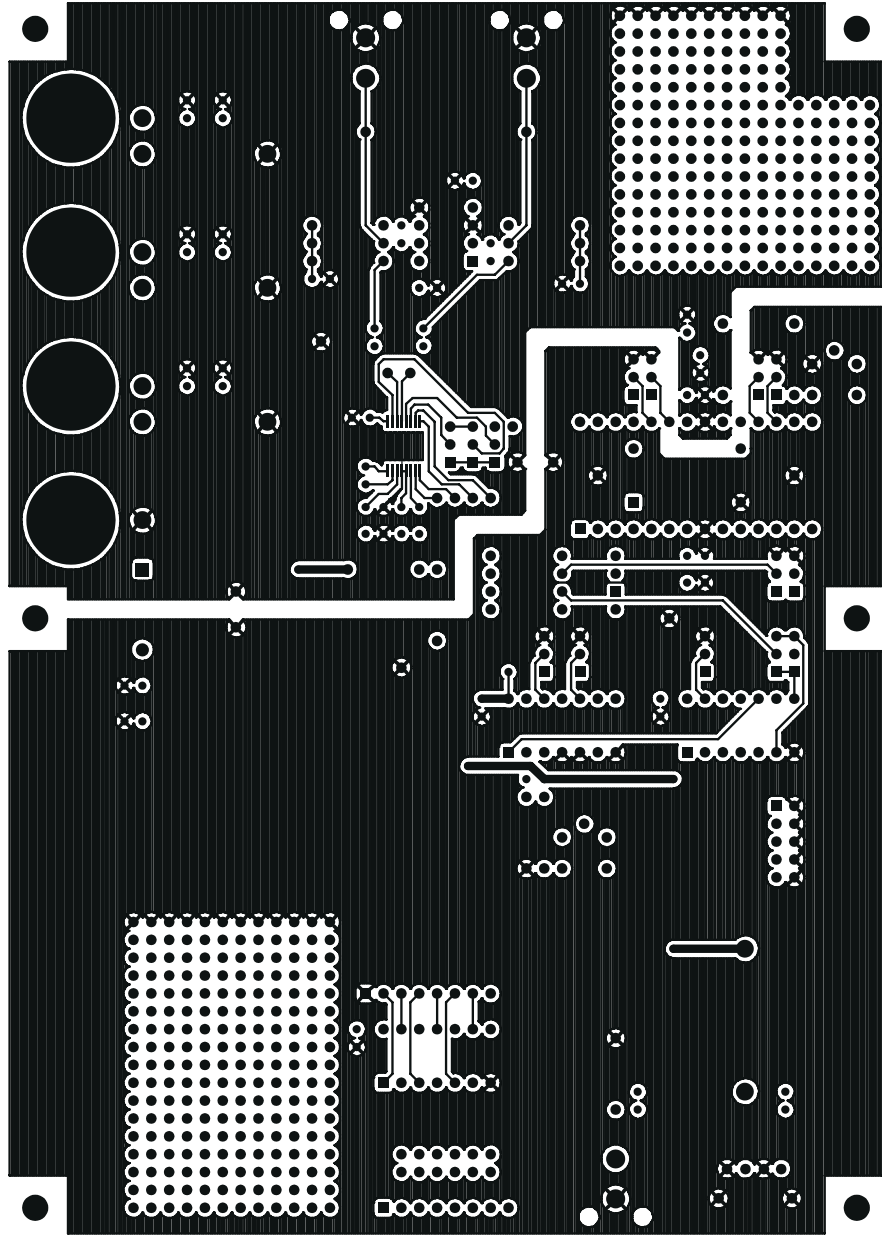

L1 COMPONENT SIDE

Figure 11. CDB4327 Component Side (top)

CRYSTAL SEMICONDUCTOR
CS4327 (SSOP-16)
P/N CDB4327-1 REV-A

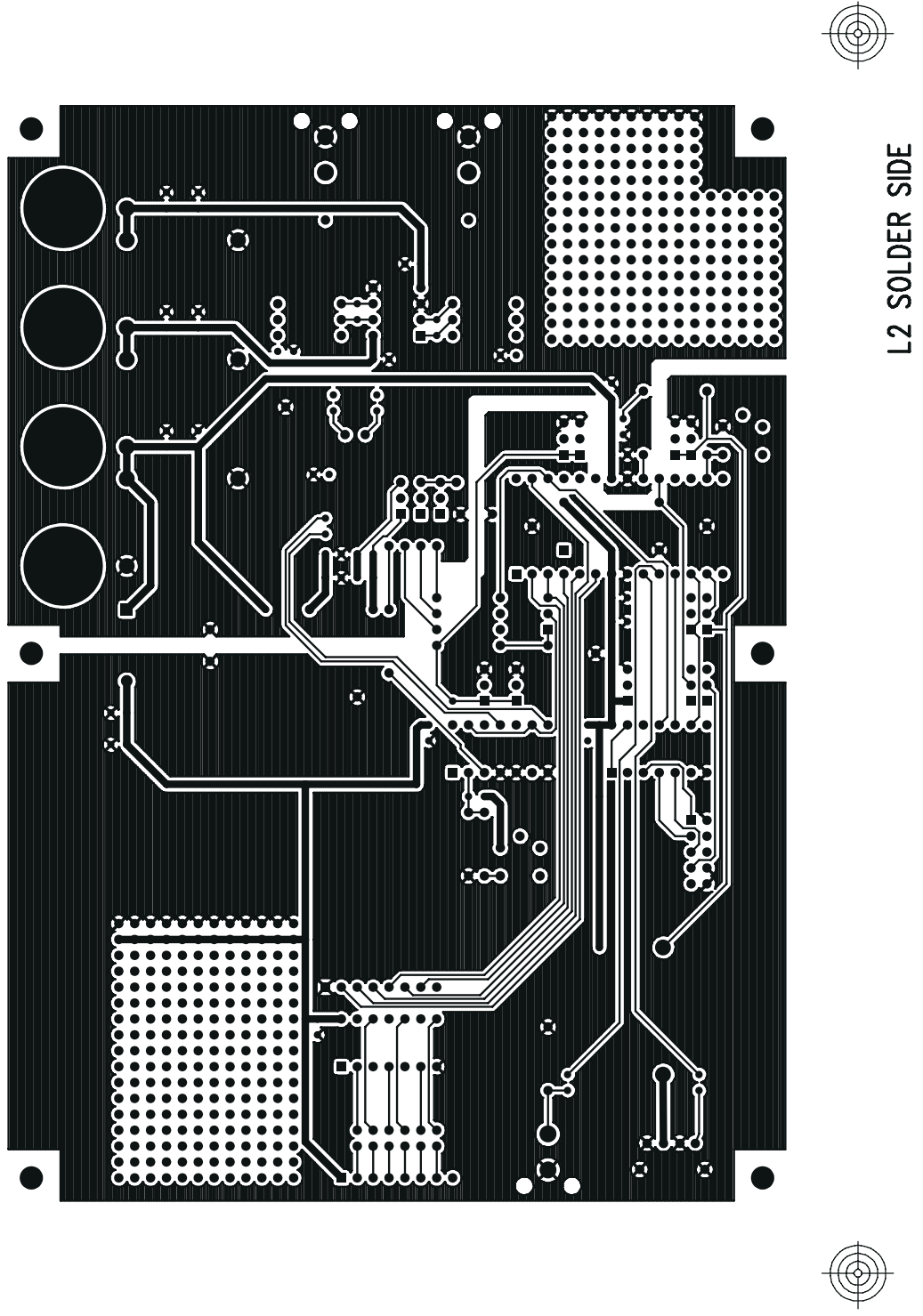

Figure 12. CDB4327 Solder Side (bottom)

• Notes •

SMART
Analog™