

N-Channel Trench Power MOSFET

General Description

The 48N10 is N-channel MOS Field Effect Transistor designed for high current switching applications. Rugged EAS capability and ultra low $R_{DS(ON)}$ is suitable for PWM, load switching especially for E-Bike controller applications.

Features

- $V_{DS}=70V$; $I_D=103A@V_{GS}=10V$;
 $R_{DS(ON)}<6.5m\Omega @V_{GS}=10V$
- Special Designed for E-Bike Controller Application
- Ultra Low On-Resistance
- High UIS and UIS 100% Test

Application

- 48V E-Bike Controller Applications
- Hard Switched and High Frequency Circuits
- Uninterruptible Power Supply

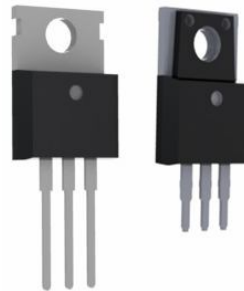

To-220 TO-220N
Top View

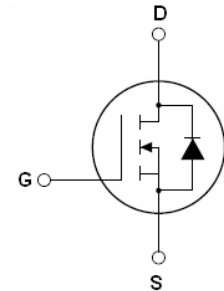

Schematic Diagram

$$V_{DS} = 70V$$

$$I_D = 103A$$

$$R_{DS(ON)} = 5m\Omega$$

Package Marking and Ordering Information

| Device Marking | Device | Device Package | Reel Size | Tape width | Quantity |
|----------------|----------|----------------|-----------|------------|----------|
| CS48N10 | CS48N10 | TO-220 | - | - | - |
| CSN48N10 | CSN48N10 | TO-220N | - | - | - |

Table 1. Absolute Maximum Ratings (TA=25°C)

| Symbol | Parameter | Value | Unit |
|-----------------|---|------------|------|
| V_{DS} | Drain-Source Voltage ($V_{GS}=0V$) | 70 | V |
| V_{GS} | Gate-Source Voltage ($V_{DS}=0V$) | ± 25 | V |
| $I_{D(DC)}$ | Drain Current (DC) at $T_c=25^\circ C$ | 103 | A |
| $I_{D(DC)}$ | Drain Current (DC) at $T_c=100^\circ C$ | 72 | A |
| $I_{DM(pluse)}$ | Drain Current-Continuous@ Current-Pulsed (Note 1) | 412 | A |
| dv/dt | Peak Diode Recovery Voltage | 8 | V/ns |
| P_D | Maximum Power Dissipation($T_c=25^\circ C$) | 153 | W |
| | Derating Factor | 1.02 | W/°C |
| EAS | Single Pulse Avalanche Energy (Note 2) | 625 | mJ |
| T_J, T_{STG} | Operating Junction and Storage Temperature Range | -55 To 175 | °C |

Notes 1.Repetitive Rating: Pulse width limited by maximum junction temperature

2.EAS condition: $T_J=25^\circ C, V_{DD}=33V, V_G=10V, I_D=50A$

Table 2. Thermal Characteristic

| Symbol | Parameter | Value | Max | Unit |
|------------------|--------------------------------------|-------|------|------|
| R _{θJC} | Thermal Resistance, Junction-to-Case | --- | 0.98 | °C/W |

Table 3. Electrical Characteristics (TA=25°C unless otherwise noted)

| Symbol | Parameter | Conditions | Min | Typ | Max | Unit |
|---|---|---|-----|------|------|------|
| On/Off States | | | | | | |
| BV _{DSS} | Drain-Source Breakdown Voltage | V _{GS} =0V, I _D =250μA | 70 | | | V |
| I _{DSS} | Zero Gate Voltage Drain Current(Tc=25°C) | V _{DS} =68V, V _{GS} =0V | | | 1 | μA |
| I _{DSS} | Zero Gate Voltage Drain Current(Tc=125°C) | V _{DS} =68V, V _{GS} =0V | | | 1 | μA |
| I _{GSS} | Gate-Body Leakage Current | V _{GS} =±25V, V _{DS} =0V | | | ±100 | nA |
| V _{GS(th)} | Gate Threshold Voltage | V _{DS} =V _{GS} , I _D =250μA | 2 | | 4 | V |
| R _{DS(ON)} | Drain-Source On-State Resistance | V _{GS} =10V, I _D =40A | | 5 | 6.5 | mΩ |
| Dynamic Characteristics | | | | | | |
| g _{FS} | Forward Transconductance | V _{DS} =10V, I _D =40A | | | | S |
| C _{iss} | Input Capacitance | V _{DS} =25V, V _{GS} =0V, f=1.0MHz | | 4057 | | pF |
| C _{oss} | Output Capacitance | | | 441 | | pF |
| C _{rss} | Reverse Transfer Capacitance | | | 325 | | pF |
| Q _g | Total Gate Charge | V _{DS} =30V, I _D =30A, V _{GS} =10V | | 112 | | nC |
| Q _{gs} | Gate-Source Charge | | | 22 | | nC |
| Q _{gd} | Gate-Drain Charge | | | 58 | | nC |
| Switching Times | | | | | | |
| t _{d(on)} | Turn-on Delay Time | V _{DD} =30V, I _D =2A, R _L =15Ω V _{GS} =10V, R _G =2.5Ω | | 27 | | nS |
| t _r | Turn-on Rise Time | | | 34 | | nS |
| t _{d(off)} | Turn-Off Delay Time | | | 74 | | nS |
| t _f | Turn-Off Fall Time | | | 33 | | nS |
| Source-Drain Diode Characteristics | | | | | | |
| I _{SD} | Source-Drain Current(Body Diode) | | | 103 | | A |
| I _{SDM} | Pulsed Source-Drain Current(Body Diode) | | | 412 | | A |
| V _{SD} | Forward On Voltage ^(Note 1) | T _J =25°C, I _{SD} =40A, V _{GS} =0V | | 0.87 | 0.99 | V |
| t _{rr} | Reverse Recovery Time ^(Note 1) | T _J =25°C, I _F =75A di/dt=100A/μs | | 29 | | nS |
| Q _{rr} | Reverse Recovery Charge ^(Note 1) | | | 41 | | nC |
| t _{on} | Forward Turn-on Time | Intrinsic turn-on time is negligible(turn-on is dominated by L _S +L _D) | | | | |

Notes 1. Pulse Test: Pulse Width ≤ 300μs, Duty Cycle ≤ 1.5%, R_G=25Ω, Starting T_J=25°C

Test Circuit

1) E_{AS} Test Circuits

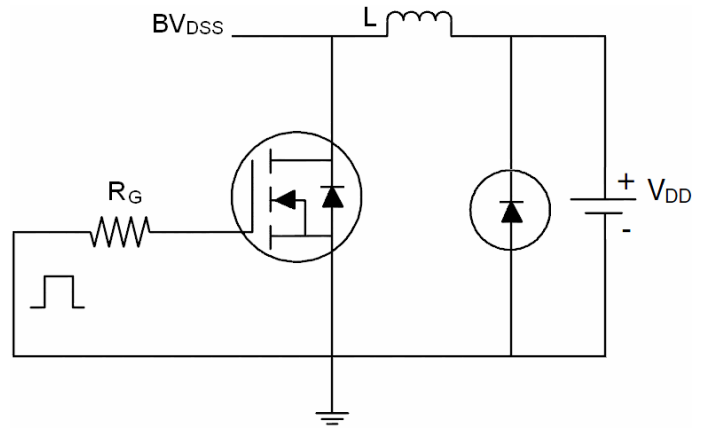
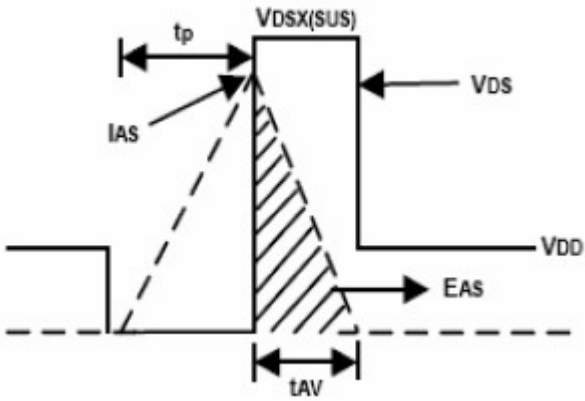

2) Gate Charge Test Circuit:

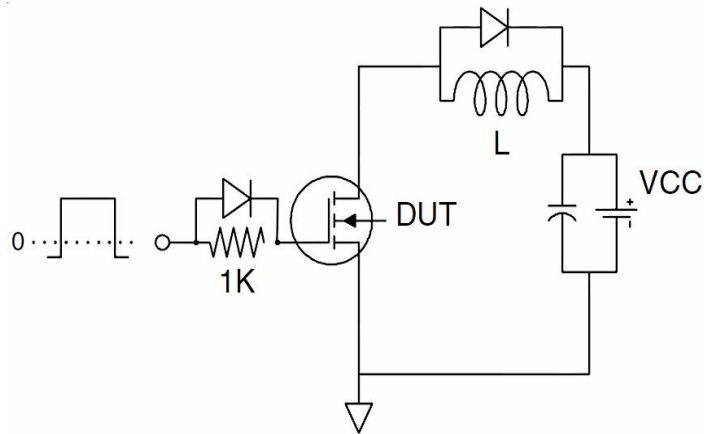
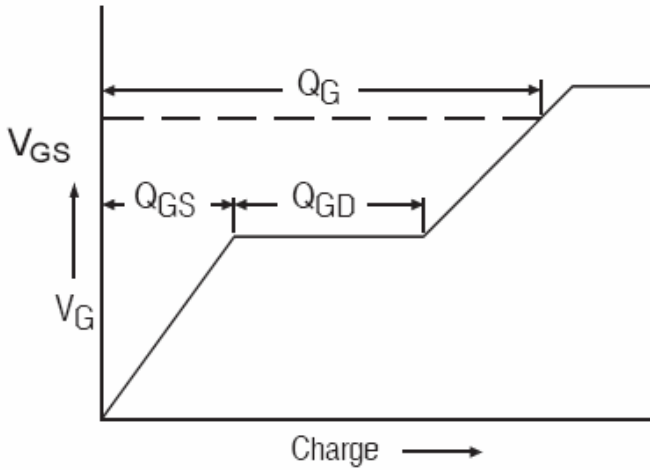

3) Switch Time Test Circuit:

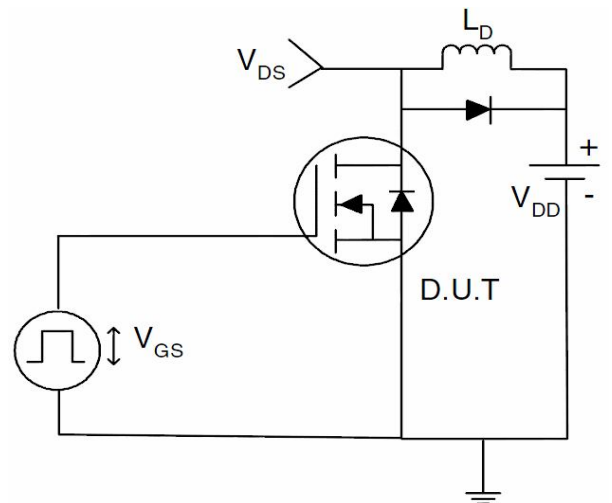
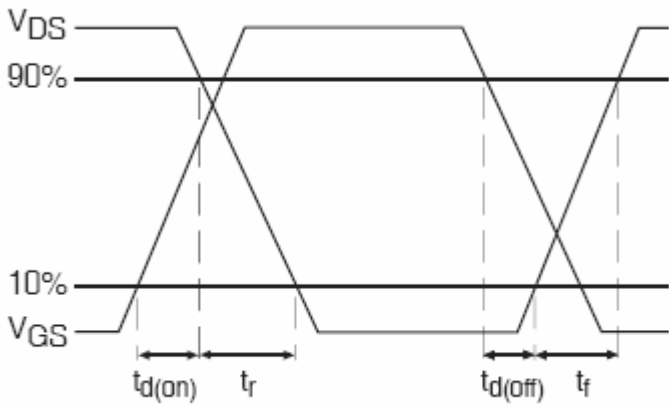

TYPICAL ELECTRICAL AND THERMAL CHARACTERISTICS (Curves)

Figure1. Output Characteristics

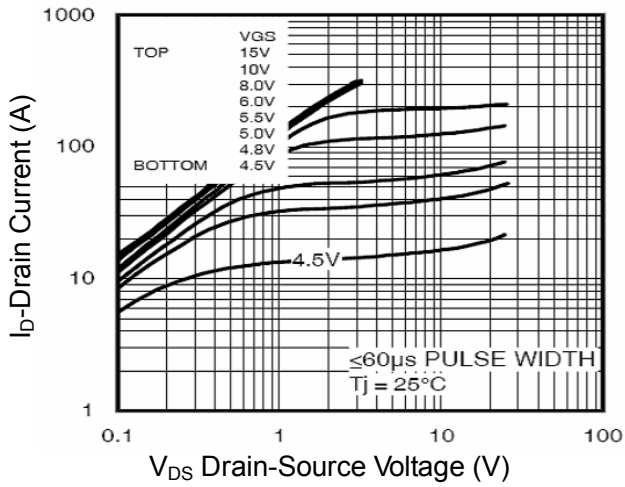

Figure2. Transfer Characteristics

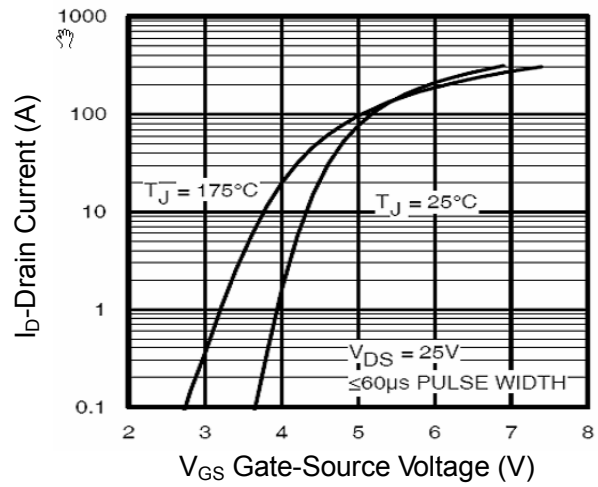

Figure3. ID vs Junction Temperature

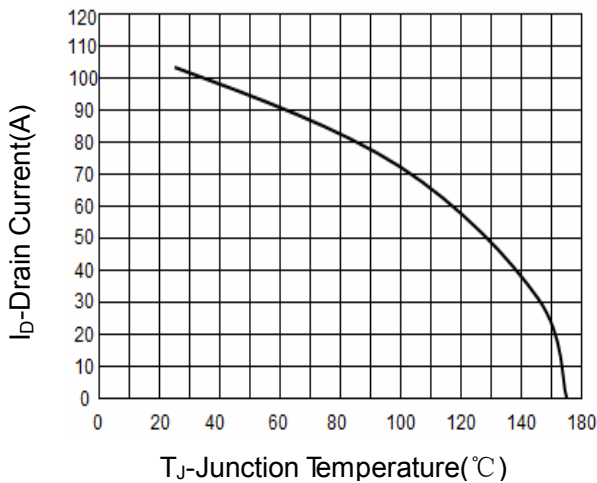

Figure4. RDS(ON) vs Junction Temperature

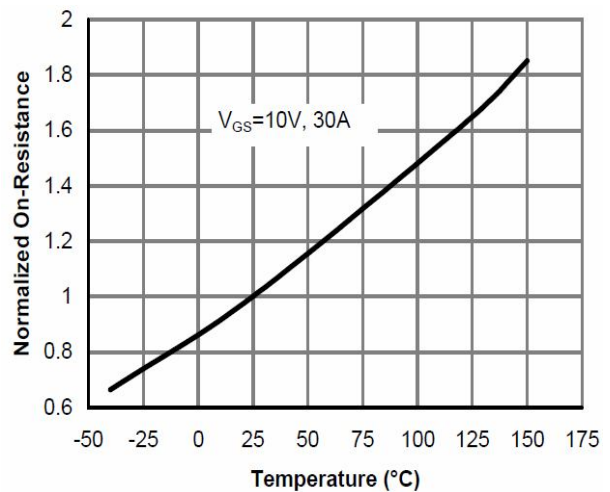

Figure5. BV_{DSS} vs Junction Temperature

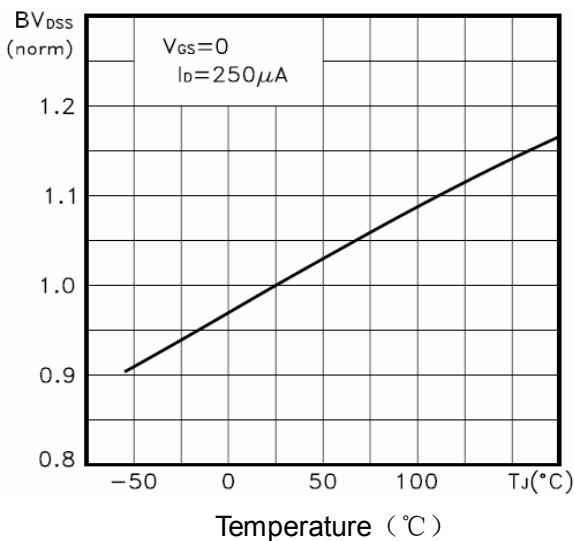

Figure6. VGS(th) vs Junction Temperature

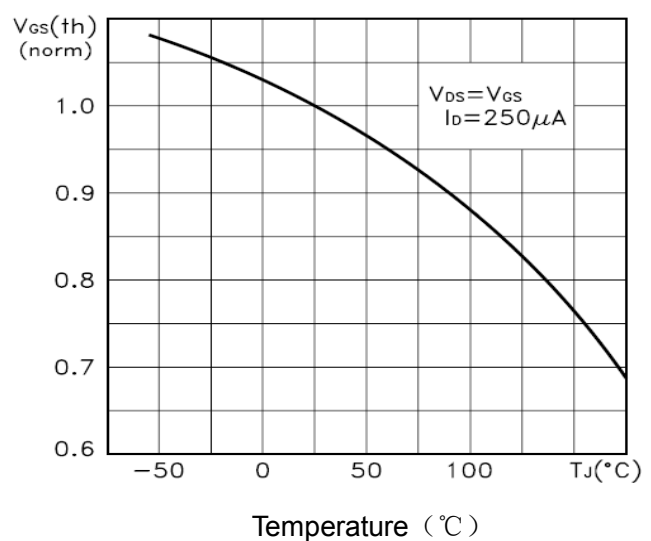

Figure7. Gate Charge

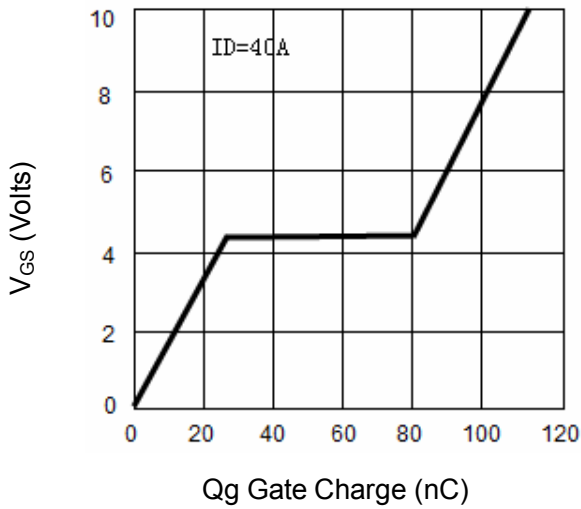

Figure8. Capacitance vs Vds

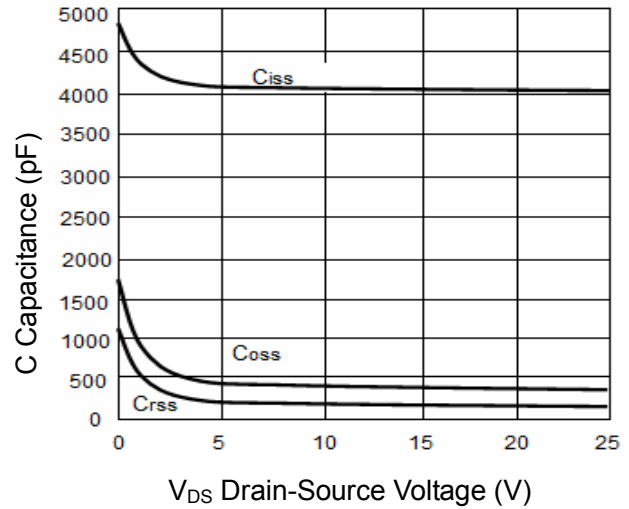

Figure9. Source- Drain Diode Forward

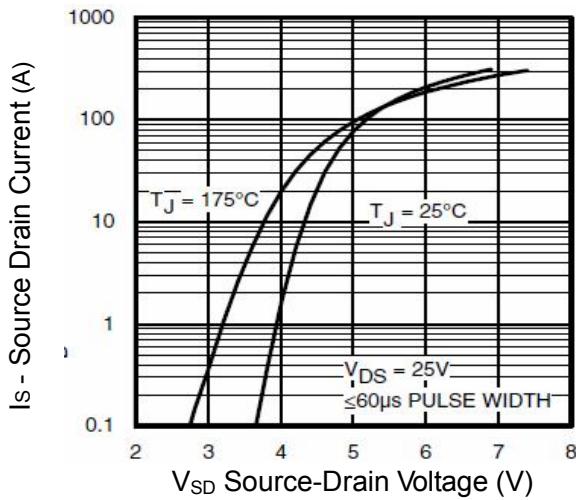

Figure10. Safe Operation Area

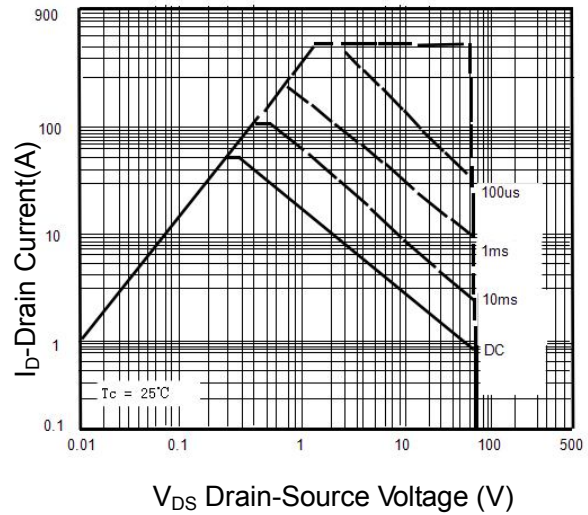
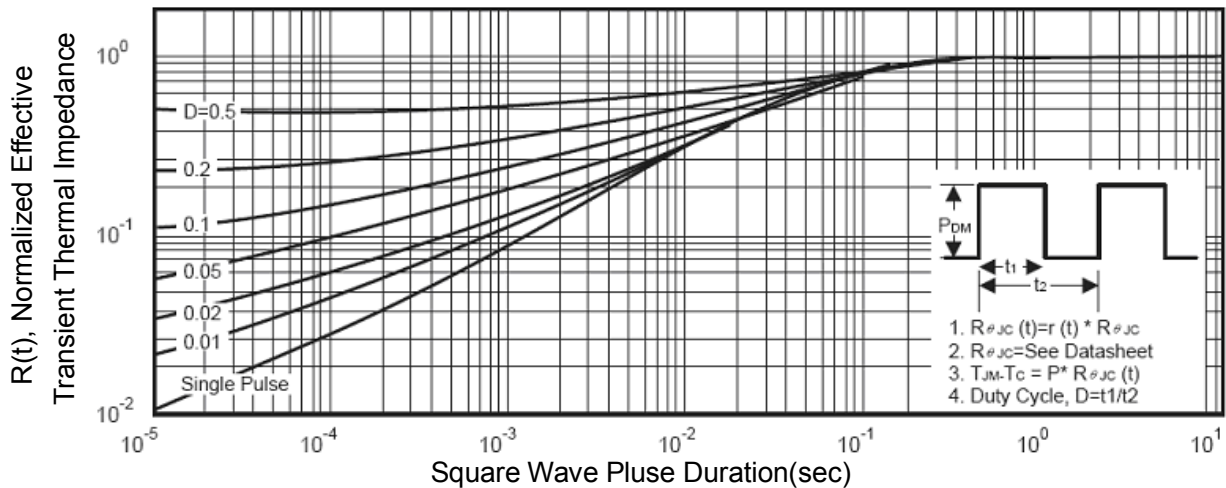
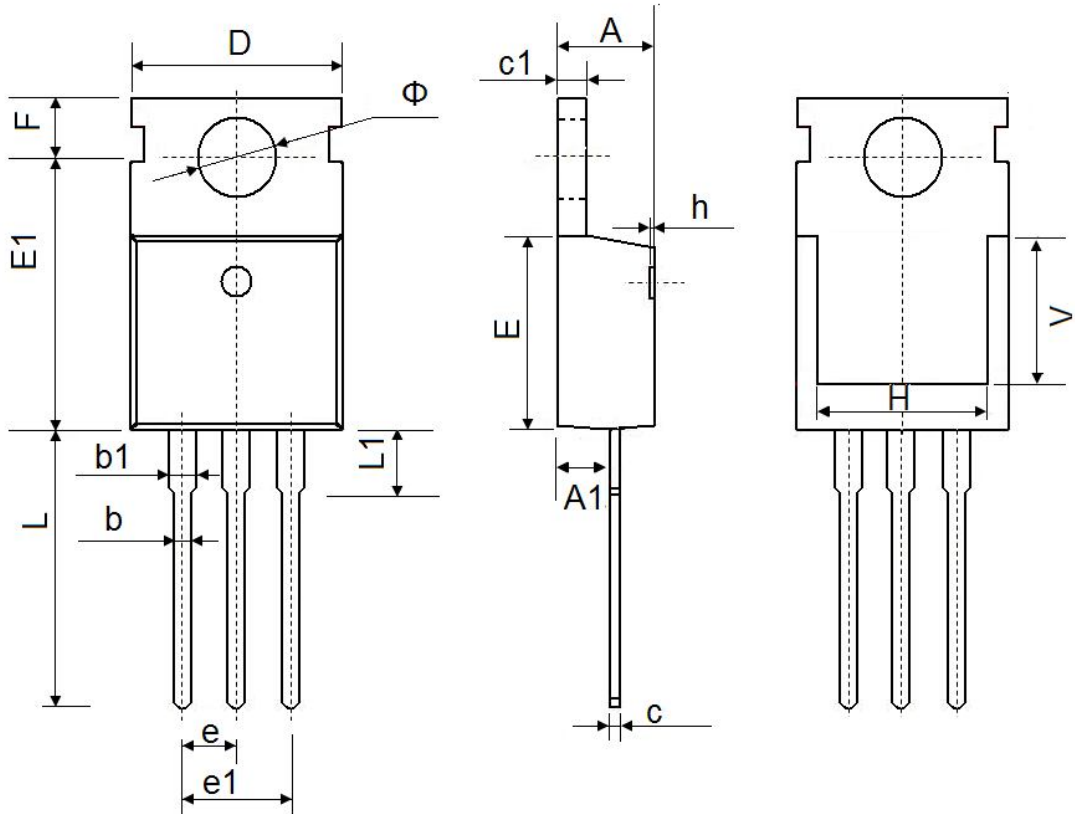

Figure11. Normalized Maximum Transient Thermal Impedance



TO-220 Package Information



| Symbol | Dimensions In Millimeters | | Dimensions In Inches | |
|--------|---------------------------|--------|----------------------|-------|
| | Min. | Max. | Min. | Max. |
| A | 4.300 | 4.700 | 0.169 | 0.185 |
| A1 | 2.200 | 2.600 | 0.087 | 0.102 |
| b | 0.700 | 0.950 | 0.028 | 0.037 |
| b1 | 1.170 | 1.410 | 0.046 | 0.056 |
| c | 0.450 | 0.650 | 0.018 | 0.026 |
| c1 | 1.200 | 1.400 | 0.047 | 0.055 |
| D | 9.600 | 10.400 | 0.378 | 0.409 |
| E | 8.8500 | 9.750 | 0.348 | 0.384 |
| E1 | 12.650 | 12.950 | 0.498 | 0.510 |
| e | 2.540 TYP. | | 0.100TYP. | |
| e1 | 4.980 | 5.180 | 0.196 | 0.204 |
| F | 2.650 | 2.950 | 0.104 | 0.116 |
| H | 7.900 | 8.100 | 0.311 | 0.319 |
| h | 0.000 | 0.300 | 0.000 | 0.012 |
| L | 12.750 | 14.300 | 0.502 | 0.563 |
| L1 | 2.850 | 3.950 | 0.112 | 0.156 |
| V | 7.500 REF. | | 0.295 REF. | |
| Φ | 3.400 | 4.000 | 0.134 | 0.157 |