

N-Channel Trench Power MOSFET

General Description

The 48N75 is N-channel MOS Field Effect Transistor designed for high current switching applications. Rugged EAS capability and ultra low $R_{DS(ON)}$ is suitable for PWM, load switching especially for E-Bike controller applications.

Features

- $V_{DS}=70V$; $I_D=68A@V_{GS}=10V$;
 $R_{DS(ON)}<8.4m\Omega @V_{GS}=10V$
- Special Designed for E-Bike Controller Application
- Ultra Low On-Resistance
- High UIS and UIS 100% Test

Application

- 48V E-Bike Controller Applications
- Hard Switched and High Frequency Circuits
- Uninterruptible Power Supply

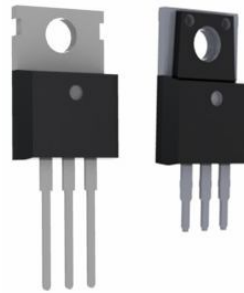

TO-220 TO-220N
Top View

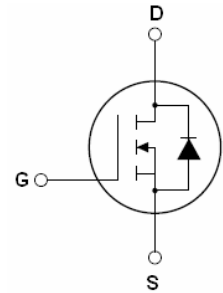

Schematic Diagram

$$V_{DS} = 70 V$$

$$I_D = 68A$$

$$R_{DS(ON)} = 7m\Omega$$

Package Marking and Ordering Information

| Device Marking | Device | Device Package | Reel Size | Tape width | Quantity |
|----------------|----------|----------------|-----------|------------|----------|
| CS48N75 | CS48N75 | TO-220 | - | - | - |
| CSN48N75 | CSN48N75 | TO-220N | | | |

Table 1. Absolute Maximum Ratings (TA=25°C)

| Symbol | Parameter | Value | Unit |
|-----------------|---|------------|------|
| V_{DS} | Drain-Source Voltage ($V_{GS}=0V$) | 70 | V |
| V_{GS} | Gate-Source Voltage ($V_{DS}=0V$) | ±25 | V |
| $I_{D(DC)}$ | Drain Current (DC) at $T_c=25^\circ C$ | 68 | A |
| $I_{D(DC)}$ | Drain Current (DC) at $T_c=100^\circ C$ | 47.6 | A |
| $I_{DM(pluse)}$ | Drain Current-Continuous@ Current-Pulsed (Note 1) | 272 | A |
| dv/dt | Peak Diode Recovery Voltage | 9.8 | V/ns |
| P_D | Maximum Power Dissipation($T_c=25^\circ C$) | 88 | W |
| | Derating Factor | 0.59 | W/°C |
| EAS | Single Pulse Avalanche Energy (Note 2) | 380 | mJ |
| T_J, T_{STG} | Operating Junction and Storage Temperature Range | -55 To 175 | °C |

Notes 1.Repetitive Rating: Pulse width limited by maximum junction temperature

2.EAS condition: $T_J=25^\circ C, V_{DD}=33V, V_G=10V$

Table 2. Thermal Characteristic

| Symbol | Parameter | Value | Max | Unit |
|------------------|--------------------------------------|-------|-----|------|
| R _{θJC} | Thermal Resistance, Junction-to-Case | --- | 1.7 | °C/W |

Table 3. Electrical Characteristics (TA=25°C unless otherwise noted)

| Symbol | Parameter | Conditions | Min | Typ | Max | Unit |
|---|---|---|-----|------|------|------|
| On/Off States | | | | | | |
| BV _{DSS} | Drain-Source Breakdown Voltage | V _{GS} =0V, I _D =250μA | 70 | | | V |
| I _{DSS} | Zero Gate Voltage Drain Current(Tc=25°C) | V _{DS} =68V, V _{GS} =0V | | | 1 | μA |
| I _{DSS} | Zero Gate Voltage Drain Current(Tc=125°C) | V _{DS} =68V, V _{GS} =0V | | | 10 | μA |
| I _{GSS} | Gate-Body Leakage Current | V _{GS} =±25V, V _{DS} =0V | | | ±100 | nA |
| V _{GS(th)} | Gate Threshold Voltage | V _{DS} =V _{GS} , I _D =250μA | 2 | | 4 | V |
| R _{DS(ON)} | Drain-Source On-State Resistance | V _{GS} =10V, I _D =40A | | 7 | 8.4 | mΩ |
| Dynamic Characteristics | | | | | | |
| g _{FS} | Forward Transconductance | V _{DS} =10V, I _D =15A | 18 | | | S |
| C _{iss} | Input Capacitance | V _{DS} =25V, V _{GS} =0V, f=1.0MHz | | 2860 | | pF |
| C _{oss} | Output Capacitance | | | 281 | | pF |
| C _{rss} | Reverse Transfer Capacitance | | | 265 | | pF |
| Q _g | Total Gate Charge | V _{DS} =50V, I _D =40A, V _{GS} =10V | | 77 | | nC |
| Q _{gs} | Gate-Source Charge | | | 15.7 | | nC |
| Q _{gd} | Gate-Drain Charge | | | 35.2 | | nC |
| Switching Times | | | | | | |
| t _{d(on)} | Turn-on Delay Time | V _{DD} =30V, I _D =2A, R _L =15Ω V _{GS} =10V, R _G =2.5Ω | | 18 | | nS |
| t _r | Turn-on Rise Time | | | 29 | | nS |
| t _{d(off)} | Turn-Off Delay Time | | | 55 | | nS |
| t _f | Turn-Off Fall Time | | | 27 | | nS |
| Source-Drain Diode Characteristics | | | | | | |
| I _{SD} | Source-Drain Current(Body Diode) | | | 68 | | A |
| I _{SDM} | Pulsed Source-Drain Current(Body Diode) | | | 272 | | A |
| V _{SD} | Forward On Voltage ^(Note 1) | T _J =25°C, I _{SD} =40A, V _{GS} =0V | | 0.89 | 0.99 | V |
| t _{rr} | Reverse Recovery Time ^(Note 1) | T _J =25°C, I _F =75A di/dt=100A/μs | | 26 | | nS |
| Q _{rr} | Reverse Recovery Charge ^(Note 1) | | | 33 | | nC |
| t _{on} | Forward Turn-on Time | Intrinsic turn-on time is negligible(turn-on is dominated by L _S +L _D) | | | | |

Notes 1. Pulse Test: Pulse Width ≤ 300μs, Duty Cycle ≤ 1.5%, R_G=25Ω, Starting T_J=25°C

Test Circuit

1) E_{AS} Test Circuits

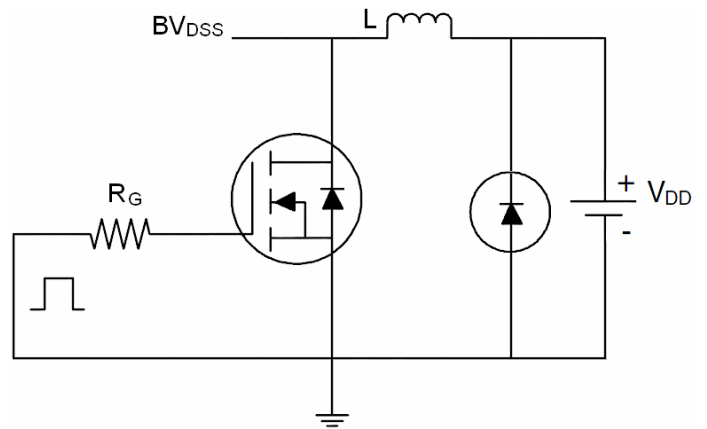
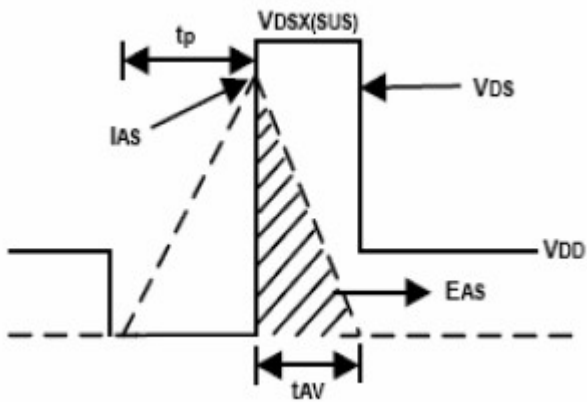

2) Gate Charge Test Circuit:

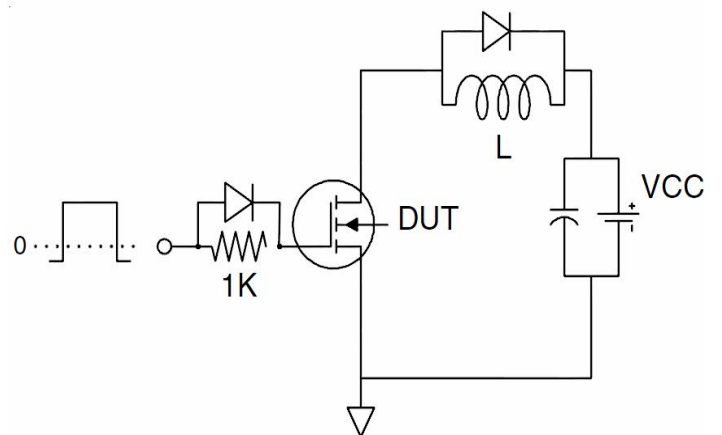
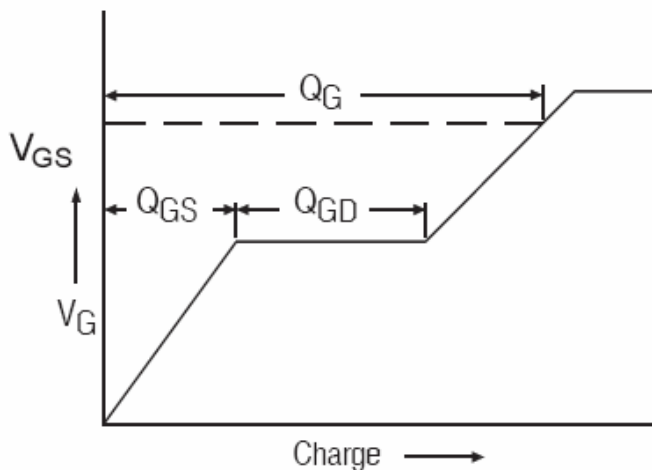

3) Switch Time Test Circuit:

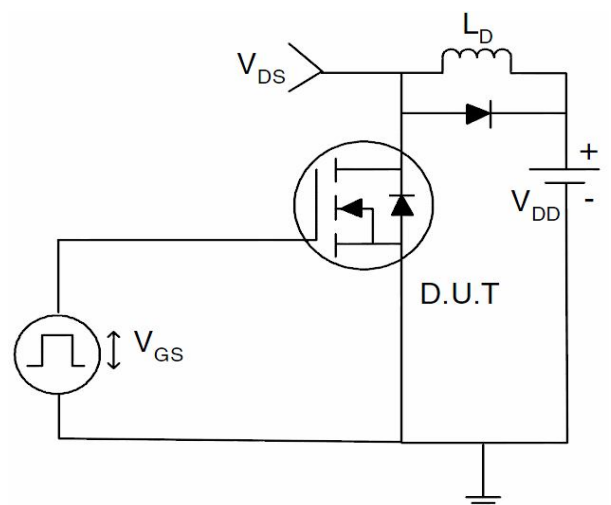
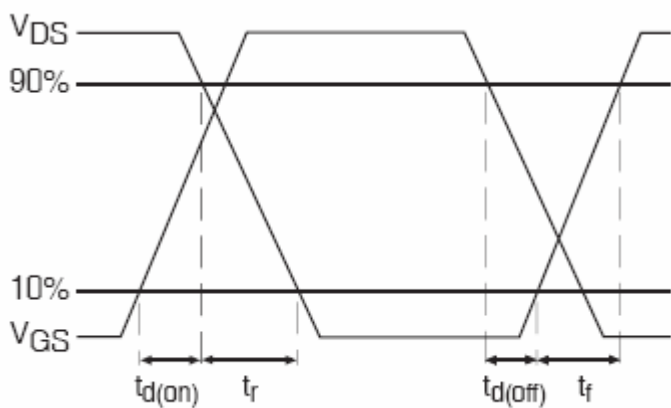

TYPICAL ELECTRICAL AND THERMAL CHARACTERISTICS (Curves)

Figure1. Output Characteristics

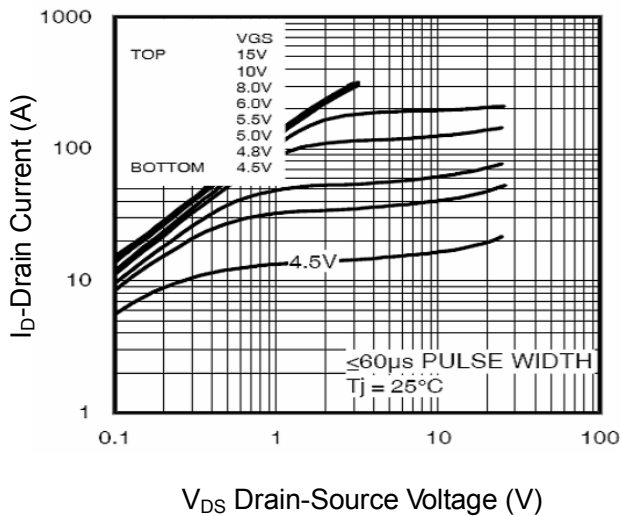

Figure2. Transfer Characteristics

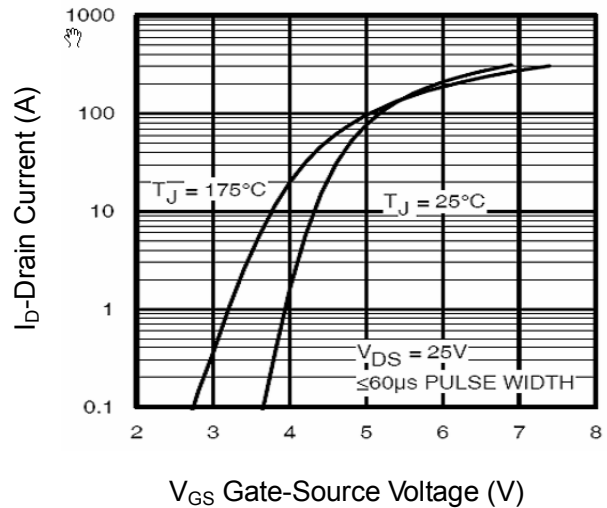

Figure3. BVDSS vs Junction Temperature

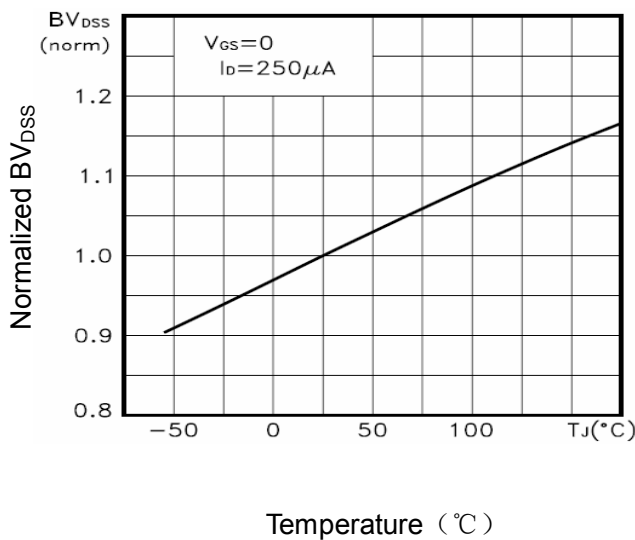

Figure4. ID vs Junction Temperature

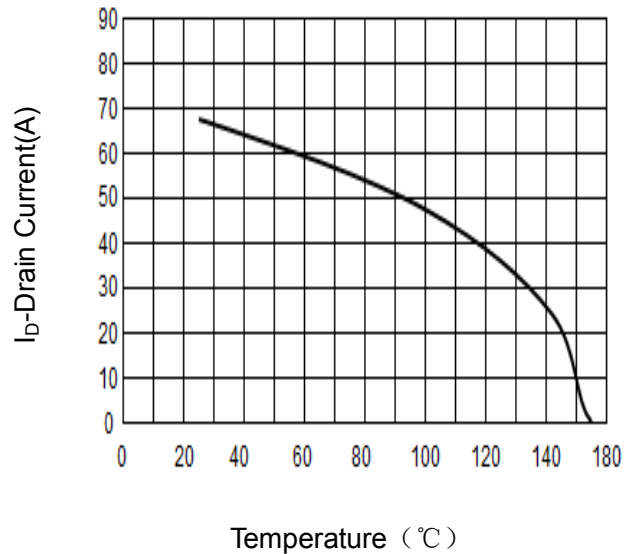

Figure5. VGS(th) vs Junction Temperature

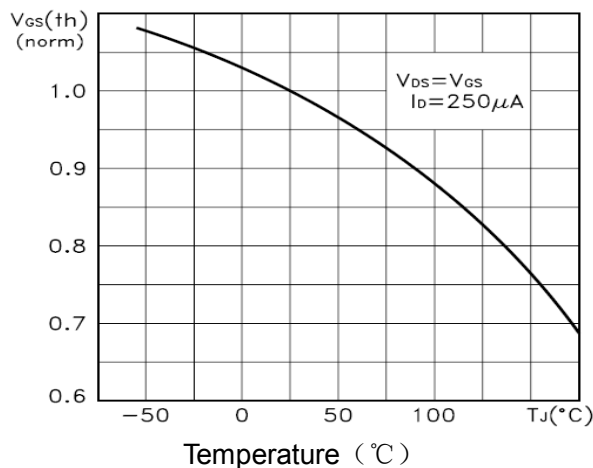

Figure6. Rds(on) Vs Junction Temperature

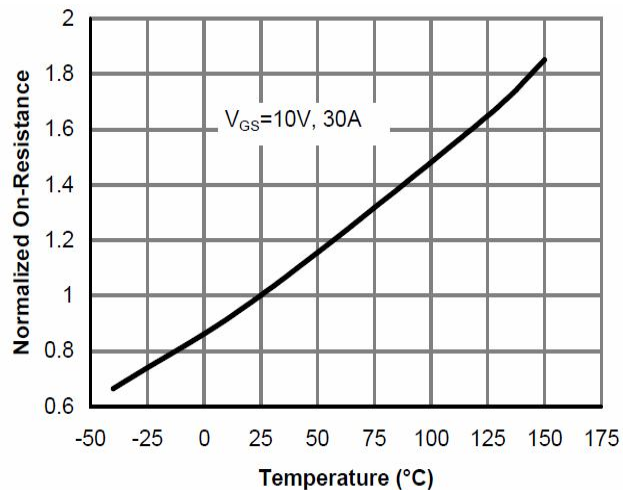

Figure7. Gate Charge

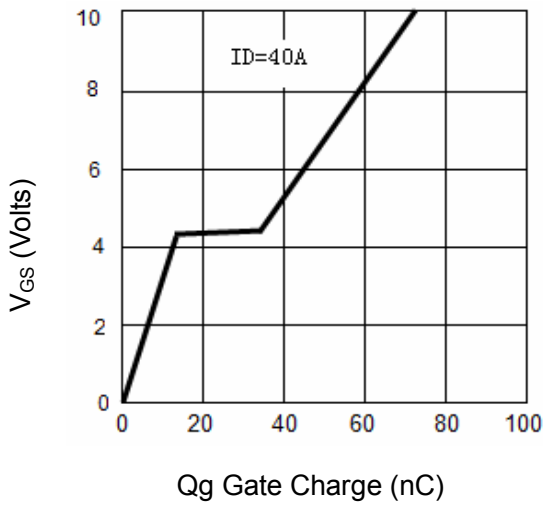

Figure8. Capacitance vs Vds

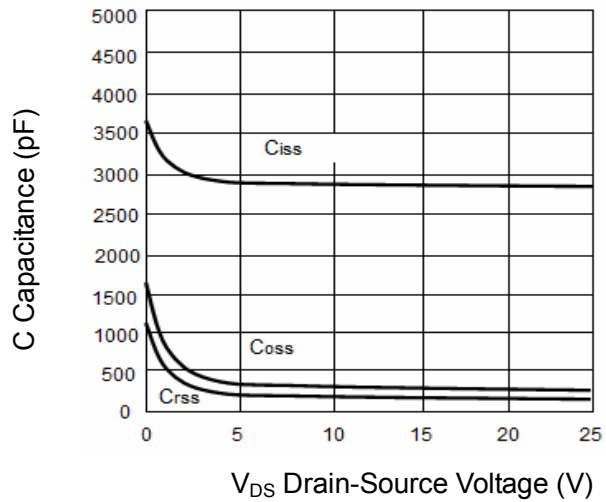

Figure9. Source- Drain Diode Forward

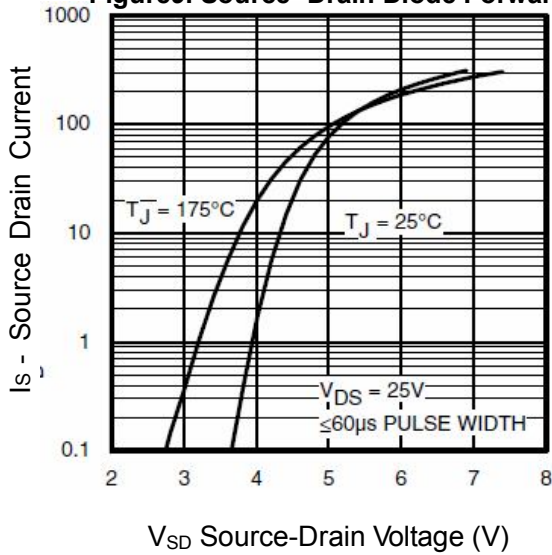

Figure10. Safe Operation Area

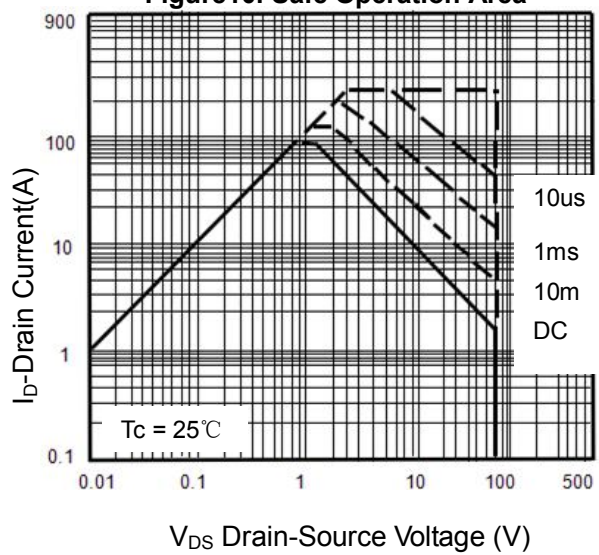
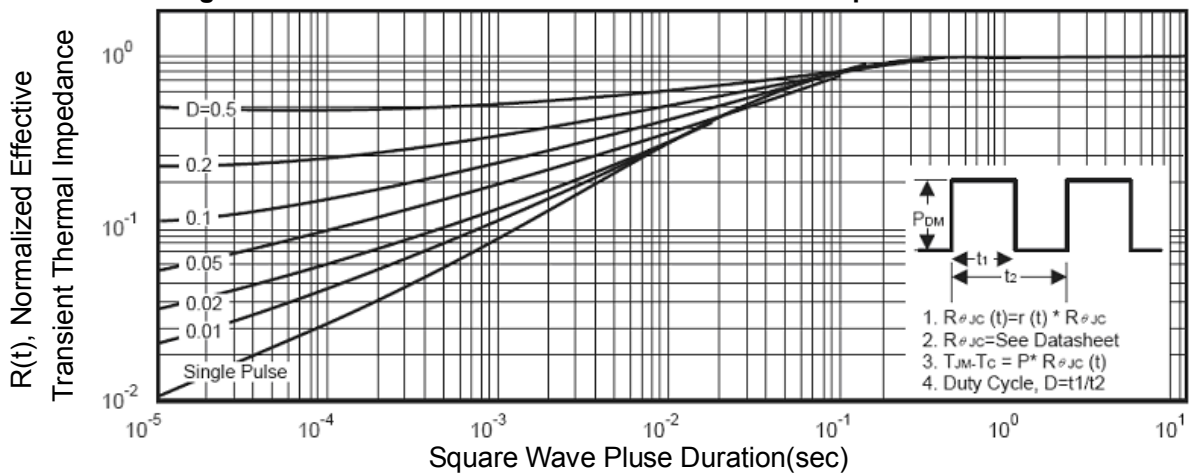
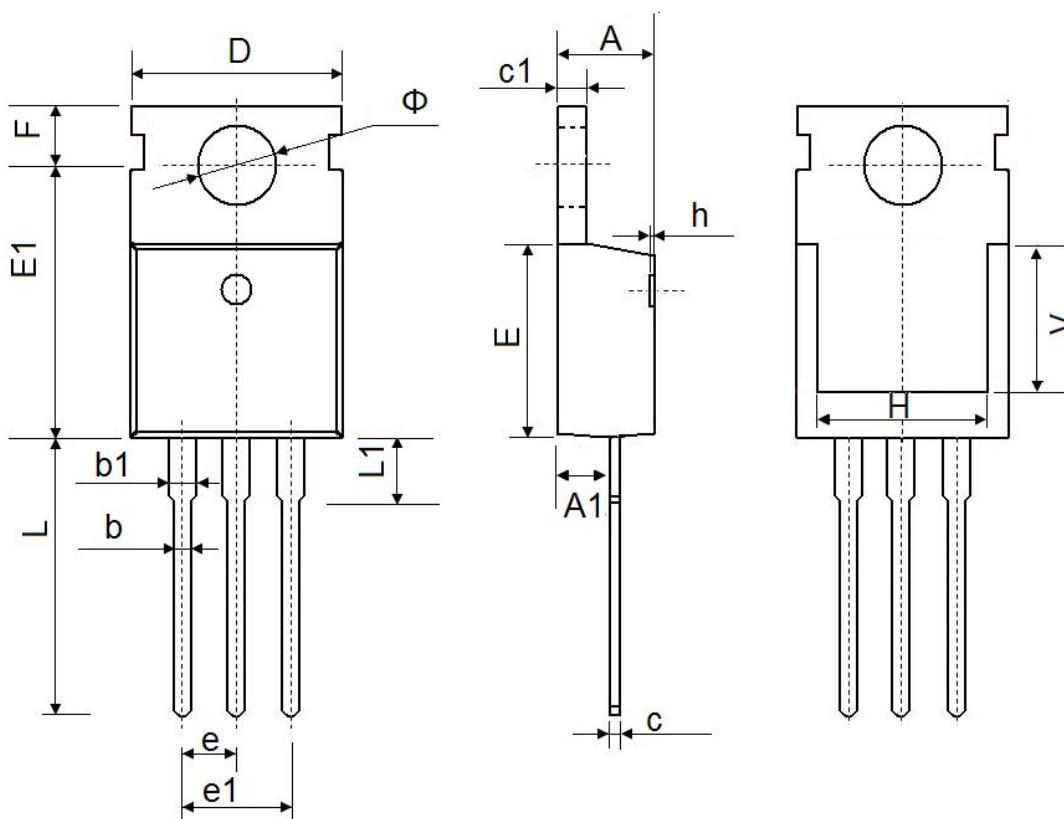

Figure11. Normalized Maximum Transient Thermal Impedance



TO-220 Package Information



| Symbol | Dimensions In Millimeters | | Dimensions In Inches | |
|--------|---------------------------|--------|----------------------|-------|
| | Min. | Max. | Min. | Max. |
| A | 4.300 | 4.700 | 0.169 | 0.185 |
| A1 | 2.200 | 2.600 | 0.087 | 0.102 |
| b | 0.700 | 0.950 | 0.028 | 0.037 |
| b1 | 1.170 | 1.410 | 0.046 | 0.056 |
| c | 0.450 | 0.650 | 0.018 | 0.026 |
| c1 | 1.200 | 1.400 | 0.047 | 0.055 |
| D | 9.600 | 10.400 | 0.378 | 0.409 |
| E | 8.8500 | 9.750 | 0.348 | 0.384 |
| E1 | 12.650 | 12.950 | 0.498 | 0.510 |
| e | 2.540 TYP. | | 0.100TYP. | |
| e1 | 4.980 | 5.180 | 0.196 | 0.204 |
| F | 2.650 | 2.950 | 0.104 | 0.116 |
| H | 7.900 | 8.100 | 0.311 | 0.319 |
| h | 0.000 | 0.300 | 0.000 | 0.012 |
| L | 12.750 | 14.300 | 0.502 | 0.563 |
| L1 | 2.850 | 3.950 | 0.112 | 0.156 |
| V | 7.500 REF. | | 0.295 REF. | |
| Φ | 3.400 | 4.000 | 0.134 | 0.157 |