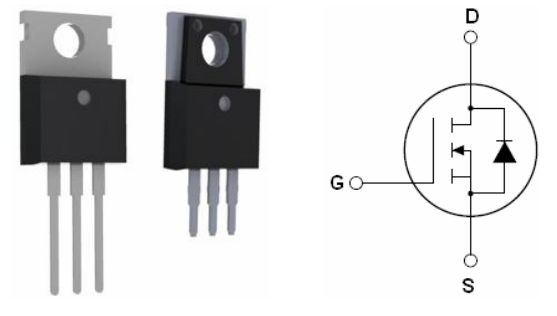

N-Channel Trench Power MOSFET

<p>General Description</p> <p>The CS64N90 is N-channel MOS Field Effect Transistor designed for high current switching applications. Rugged EAS capability and ultra low $R_{DS(ON)}$ is suitable for PWM, load switching especially for E-Bike controller applications.</p> <p>Features</p> <ul style="list-style-type: none"> ● $V_{DS}=82V$; $I_D=92A @ V_{GS}=10V$; $R_{DS(ON)} < 7.8m\Omega @ V_{GS}=10V$ ● Special Designed for E-Bike Controller Application ● Ultra Low On-Resistance ● High UIS and UIS 100% Test <p>Application</p> <ul style="list-style-type: none"> ● 64V E-Bike Controller Applications ● Hard Switched and High Frequency Circuits ● Uninterruptible Power Supply 	 <p style="text-align: center;">To-220 TO-220N Top View</p> <p style="text-align: center;">Schematic Diagram</p> <p style="text-align: center;">$V_{DS} = 82 V$</p> <p style="text-align: center;">$I_D = 92A$</p> <p style="text-align: center;">$R_{DS(ON)} = 6.5 m\Omega$</p>
---	--

Package Marking and Ordering Information

Device Marking	Device	Device Package	Reel Size	Tape width	Quantity
CS64N90	CS64N90	TO-220	-	-	-
CSN64N90	CSN64N90	TO-220N	-	-	-

Table 1. Absolute Maximum Ratings (TA=25°C)

Symbol	Parameter	Value	Unit
V_{DS}	Drain-Source Voltage ($V_{GS}=0V$)	82	V
V_{GS}	Gate-Source Voltage ($V_{DS}=0V$)	± 25	V
$I_{D(DC)}$	Drain Current (DC) at $T_c=25^\circ C$	92	A
$I_{D(DC)}$	Drain Current (DC) at $T_c=100^\circ C$	64.4	A
$I_{DM(pluse)}$	Drain Current-Continuous@ Current-Pulsed (Note 1)	368	A
dv/dt	Peak Diode Recovery Voltage	7.3	V/ns
P_D	Maximum Power Dissipation($T_c=25^\circ C$)	147	W
	Derating Factor	0.93	W/°C
EAS	Single Pulse Avalanche Energy (Note 2)	625	mJ
T_J, T_{STG}	Operating Junction and Storage Temperature Range	-55 To 175	°C

Notes 1.Repetitive Rating: Pulse width limited by maximum junction temperature

2.EAS condition: $T_J=25^\circ C, V_{DD}=40V, V_G=10V, R_G=25\Omega$

Table 2. Thermal Characteristic

Symbol	Parameter	Value	Max	Unit
R _{θJC}	Thermal Resistance, Junction-to-Case	---	1.02	°C/W

Table 3. Electrical Characteristics (TA=25°C unless otherwise noted)

Symbol	Parameter	Conditions	Min	Typ	Max	Unit
On/Off States						
BV _{DSS}	Drain-Source Breakdown Voltage	V _{GS} =0V, I _D =250μA	82			V
I _{DSS}	Zero Gate Voltage Drain Current(Tc=25°C)	V _{DS} =82V, V _{GS} =0V			1	μA
I _{DSS}	Zero Gate Voltage Drain Current(Tc=125°C)	V _{DS} =82V, V _{GS} =0V			10	μA
I _{GSS}	Gate-Body Leakage Current	V _{GS} =±20V, V _{DS} =0V			±100	nA
V _{GS(th)}	Gate Threshold Voltage	V _{DS} =V _{GS} , I _D =250μA	2		4	V
R _{DS(ON)}	Drain-Source On-State Resistance	V _{GS} =10V, I _D =40A		6.5	7.8	mΩ
Dynamic Characteristics						
g _{FS}	Forward Transconductance	V _{DS} =10V, I _D =15A	20			S
C _{iss}	Input Capacitance	V _{DS} =25V, V _{GS} =0V, f=1.0MHz		5053		PF
C _{oss}	Output Capacitance			442		PF
C _{rss}	Reverse Transfer Capacitance			145		PF
Q _g	Total Gate Charge	V _{DS} =50V, I _D =40A, V _{GS} =10V		115		nC
Q _{gs}	Gate-Source Charge			20		nC
Q _{gd}	Gate-Drain Charge			50		nC
Switching Times						
t _{d(on)}	Turn-on Delay Time	V _{DD} =30V, I _D =40A, R _L =15Ω V _{GS} =10V, R _G =2.5Ω		23		nS
t _r	Turn-on Rise Time			51		nS
t _{d(off)}	Turn-Off Delay Time			66		nS
t _f	Turn-Off Fall Time			23		nS
Source-Drain Diode Characteristics						
I _{SD}	Source-drain Current(Body Diode)			92		A
I _{SDM}	Pulsed Source-Drain Current(Body Diode)			368		A
V _{SD}	Forward On Voltage ^(Note 1)	T _J =25°C, I _{SD} =40A, V _{GS} =0V		0.89	0.99	V
t _{rr}	Reverse Recovery Time ^(Note 1)	T _J =25°C, I _F =75A di/dt=100A/μs		41		nS
Q _{rr}	Reverse Recovery Charge ^(Note 1)			86		nC
t _{on}	Forward Turn-on Time	Intrinsic turn-on time is negligible(turn-on is dominated by L _S +L _D)				

Notes 1. Pulse Test: Pulse Width ≤ 300μs, Duty Cycle ≤ 1.5%, R_G=25Ω, Starting T_J=25°C

Test Circuit

1) E_{AS} Test Circuits

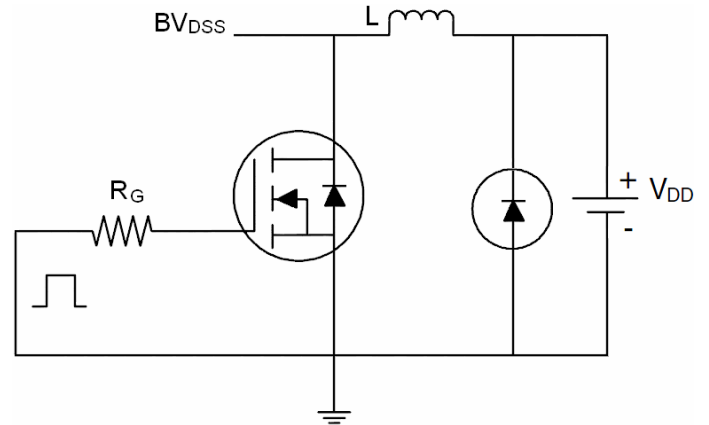
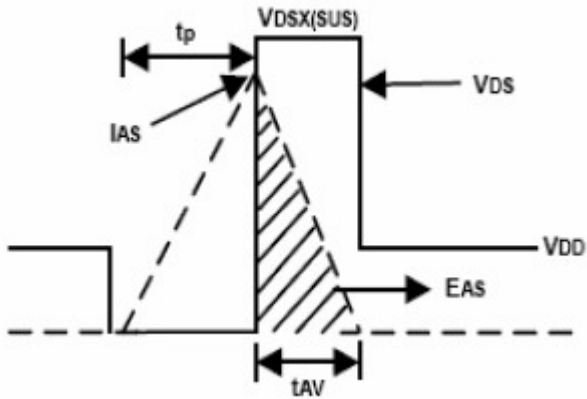

2) Gate Charge Test Circuit:

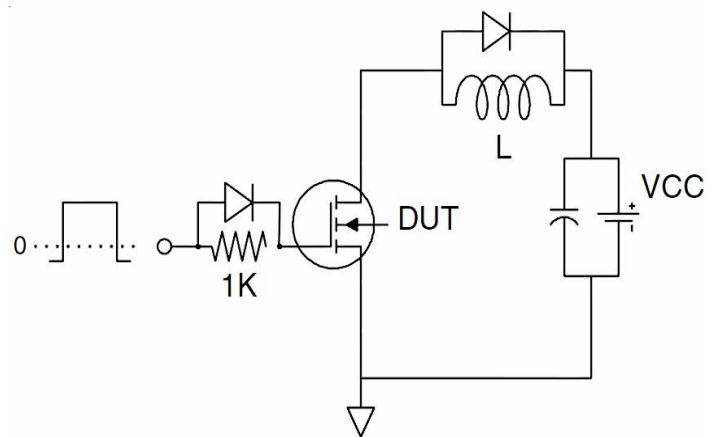
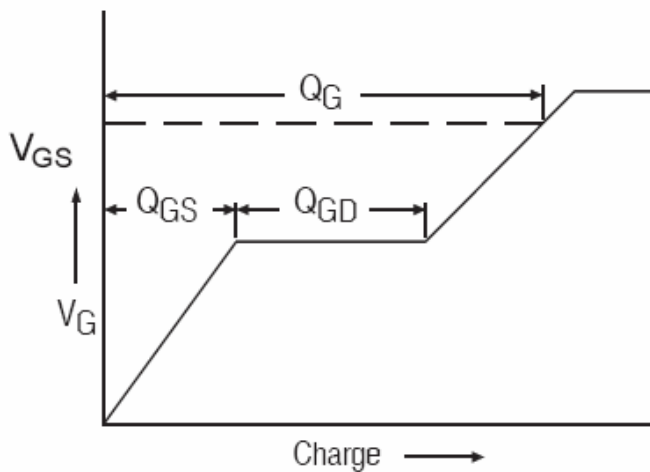

3) Switch Time Test Circuit:

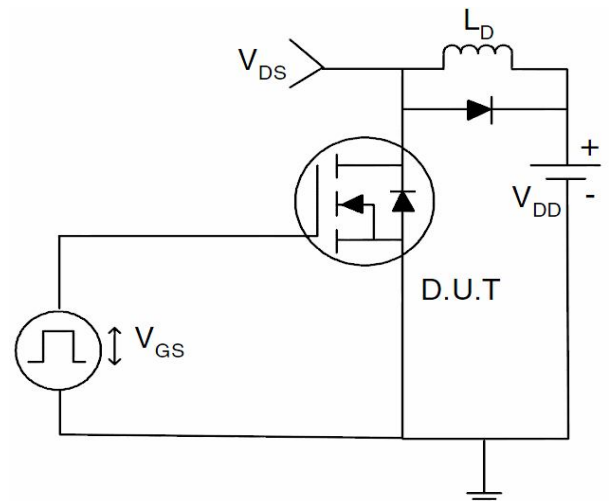
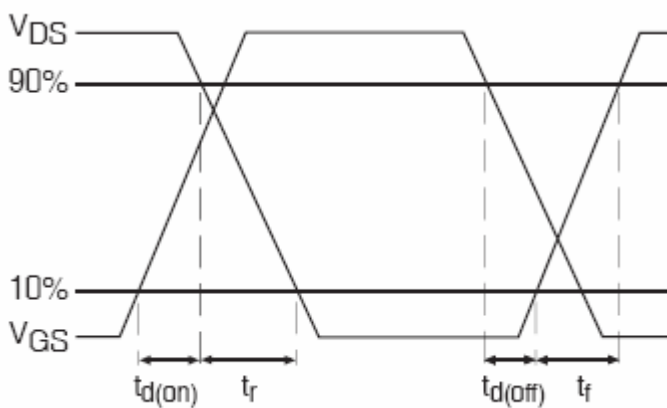

TYPICAL ELECTRICAL AND THERMAL CHARACTERISTICS (Curves)

Figure1. Output Characteristics

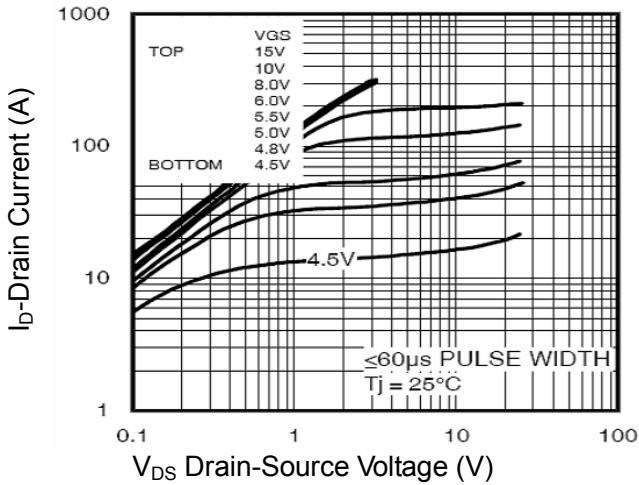

Figure2. Transfer Characteristics

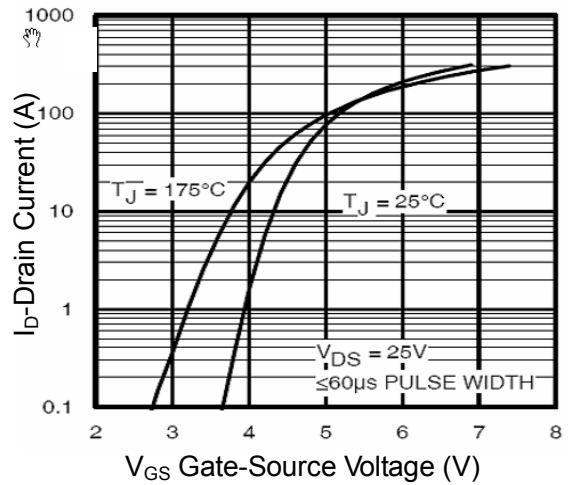

Figure3. BV_{DSS} vs Junction Temperature

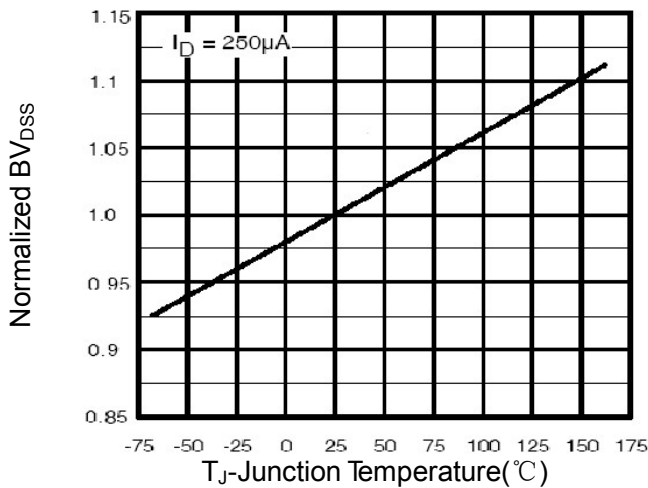

Figure4. ID vs Junction Temperature

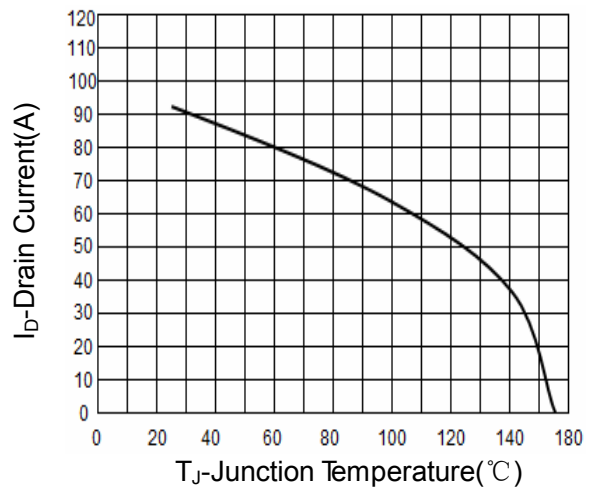

Figure5. VGS(th) vs Junction Temperature

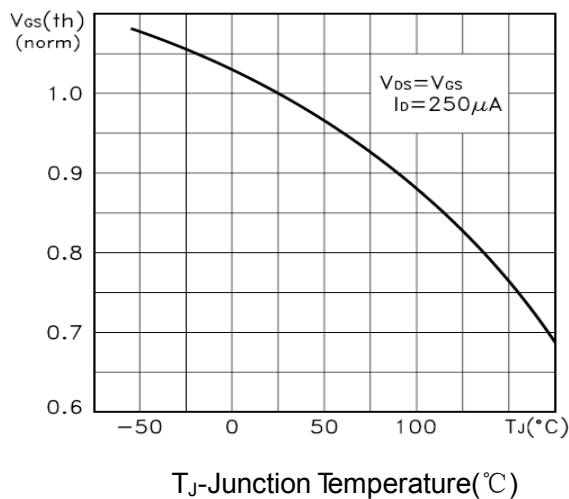

Figure6. R_{dson} Vs Junction Temperature

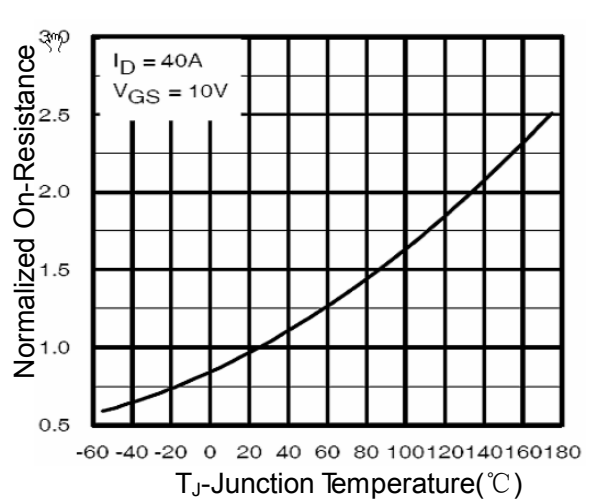

Figure7. Gate Charge

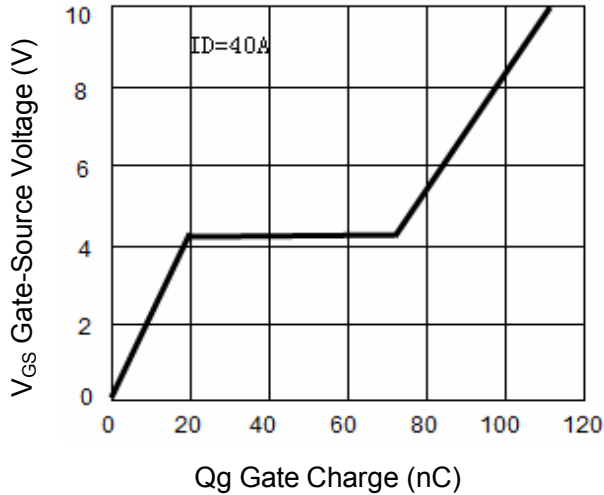

Figure8. Capacitance vs V_{ds}

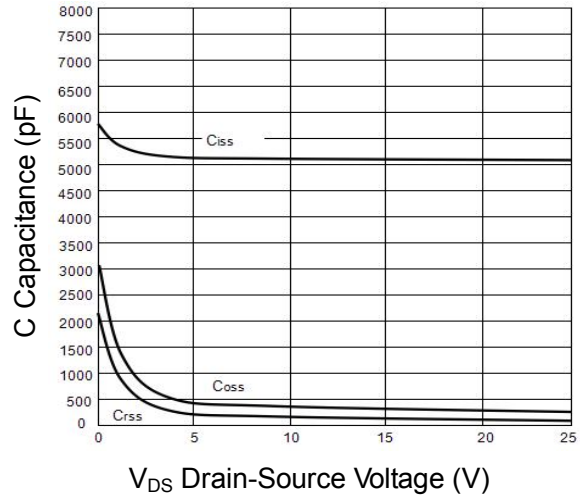

Figure9. Source- Drain Diode Forward

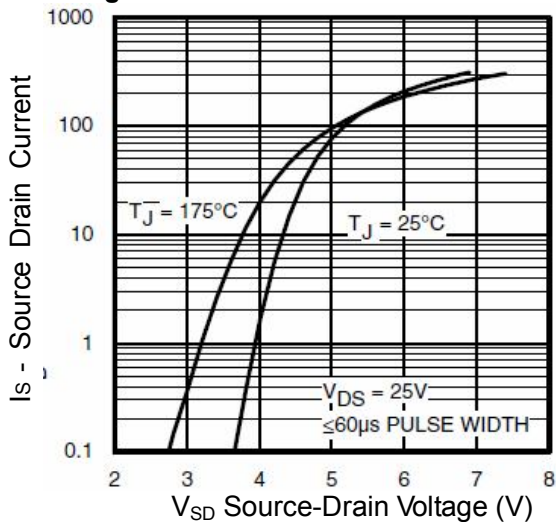

Figure10. Safe Operation Area

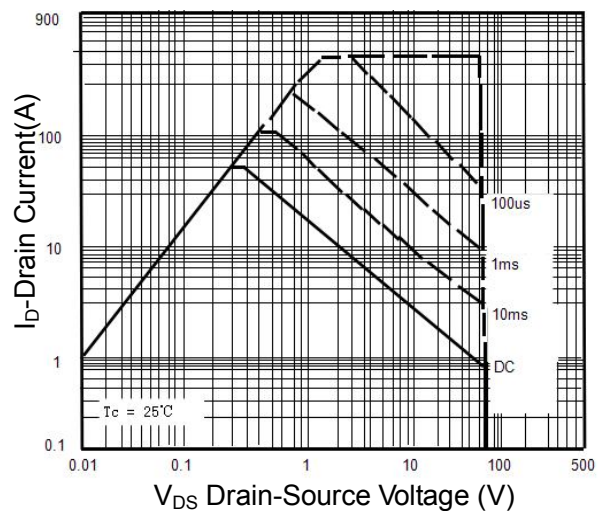
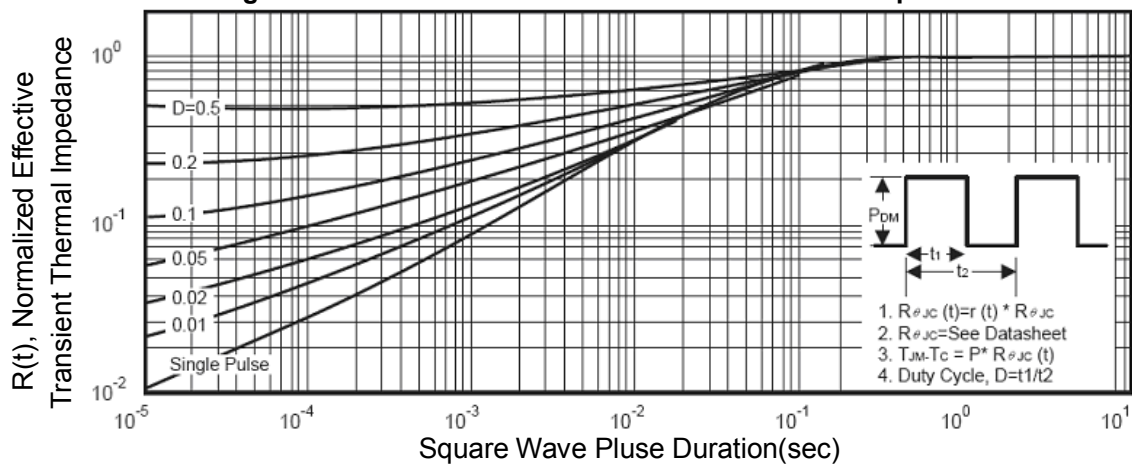
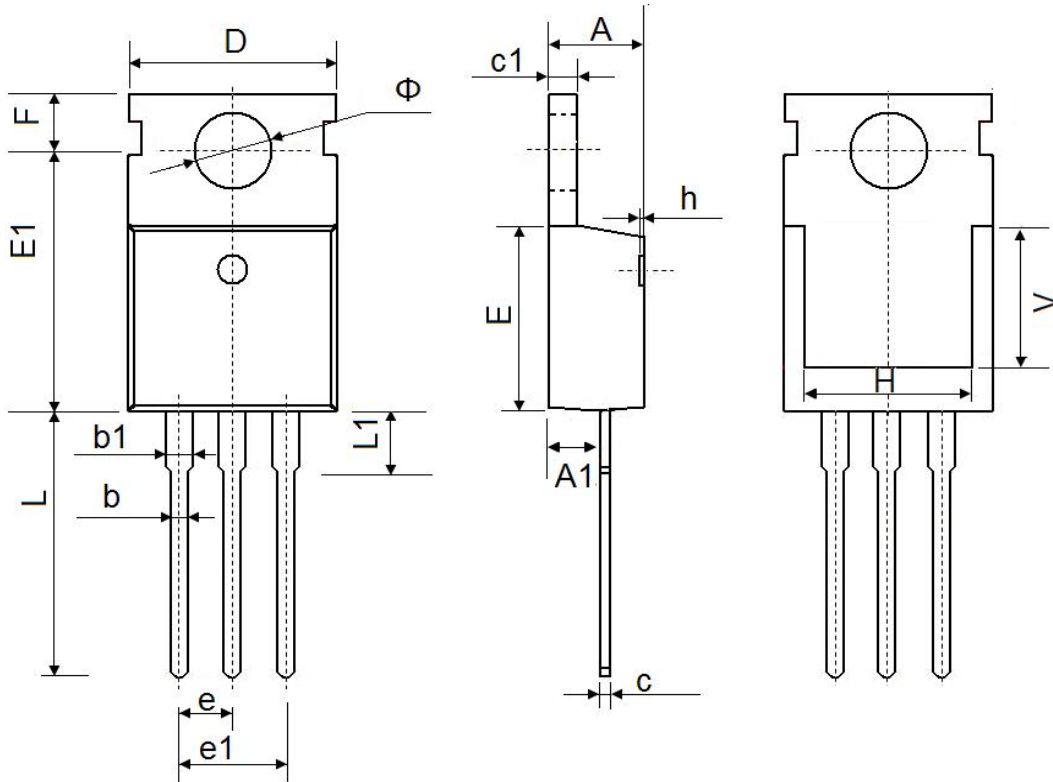

Figure11. Normalized Maximum Transient Thermal Impedance



TO-220 Package Information



Symbol	Dimensions In Millimeters		Dimensions In Inches	
	Min.	Max.	Min.	Max.
A	4.300	4.700	0.169	0.185
A1	2.200	2.600	0.087	0.102
b	0.700	0.950	0.028	0.037
b1	1.170	1.410	0.046	0.056
c	0.450	0.650	0.018	0.026
c1	1.200	1.400	0.047	0.055
D	9.600	10.400	0.378	0.409
E	8.8500	9.750	0.348	0.384
E1	12.650	12.950	0.498	0.510
e	2.540 TYP.		0.100TYP.	
e1	4.980	5.180	0.196	0.204
F	2.650	2.950	0.104	0.116
H	7.900	8.100	0.311	0.319
h	0.000	0.300	0.000	0.012
L	12.750	14.300	0.502	0.563
L1	2.850	3.950	0.112	0.156
V	7.500 REF.		0.295 REF.	
φ	3.400	4.000	0.134	0.157