

Digital MEMS Microphone with High Performance and Low Power Modes

Features

- High acoustic overload point (AOP, 131 dB SPL)
- High signal-to-noise ratio (SNR, 66 dB)
- Low variation in sensitivity (± 1 dB)
- Low current consumption
 - 650 μ A (High Performance Mode)
 - 160 μ A (Low Power Mode)
 - 5 μ A (Standby Mode)
- PDM digital audio output
- Bottom-port LGA package
- 1.8-V supply

Description

The CS7250B is a high-performance digital MEMS microphone, offering class-leading total harmonic distortion (THD) performance, excellent SNR, and low power consumption.

The CS7250B supports two operational modes, selected according to the applied clock frequency. Low Power Mode is ideal for always-on voice activity detection; High Performance Mode is optimized for high fidelity recording.

The CS7250B incorporates a high-performance ADC, which outputs a single-bit data stream using pulse density modulation (PDM) encoding. The CS7250B supports selectable left/right channel assignment for a two-channel digital microphone interface, enabling efficient connection of multiple microphones in stereo/array configurations.

The CS7250B is available in a 3.50 x 2.65 x 0.98-mm bottom-port LGA package, with port diameter of 0.325 mm. It is ideal for portable applications such as smartphones, tablets, wearables and portable speech-recognition devices.

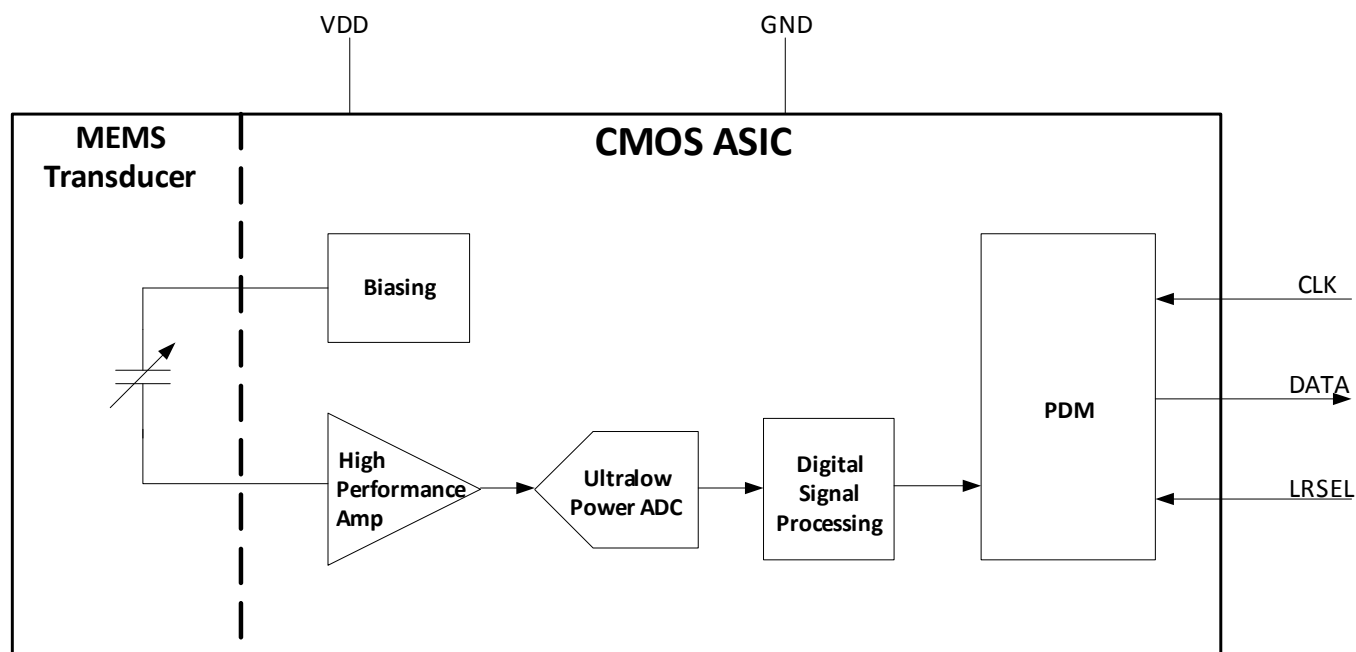

Preliminary Product Information

This document contains information for a new product. Cirrus Logic reserves the right to modify this product without notice.

Table of Contents

1 Pin Descriptions	3
1.1 LGA Pinout	3
1.2 Pin Descriptions	3
2 Typical Connection Diagram	4
3 Characteristics and Specifications	5
Table 3-1. Parameter Definitions	5
Table 3-2. Recommended Operating Conditions	5
Table 3-3. Absolute Maximum Ratings	5
Table 3-4. Acoustic and Electrical Characteristics	6
Table 3-5. Audio Interface Timing	7
4 Typical Performance	8
4.1 Audio Frequency Response	8
4.2 THD Performance	8
5 Applications Information	9
5.1 Important Assembly Guidelines	9
5.2 PCB Land Pattern and Paste Stencil	9
6 Package Dimension	10
7 Ordering Information	10
8 References	11
9 Revision History	11

1 Pin Descriptions

1.1 LGA Pinout

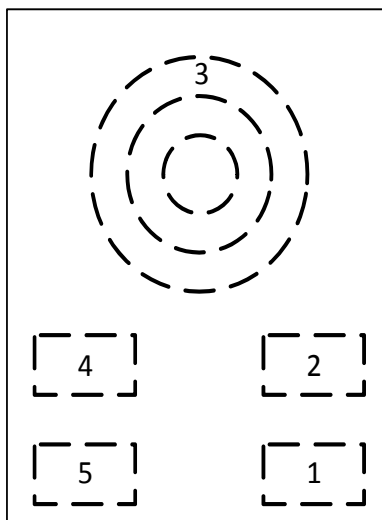

Figure 1-1. Top-Down (Through-Package) View

1.2 Pin Descriptions

A description of each pin on the CS7250B is provided in [Table 1-1](#).

Table 1-1. Pin Descriptions

Name	Pin #	I/O	Description
DATA	1	O	PDM data output
LRSEL	2	I	Channel select 0 = Data output following falling CLK edge 1 = Data output following rising CLK edge This pin must be tied to VDD or GND—there is no internal pull-up/-down provided.
GND	3		Ground
CLK	4	I	Clock input
VDD	5		Power supply

2 Typical Connection Diagram

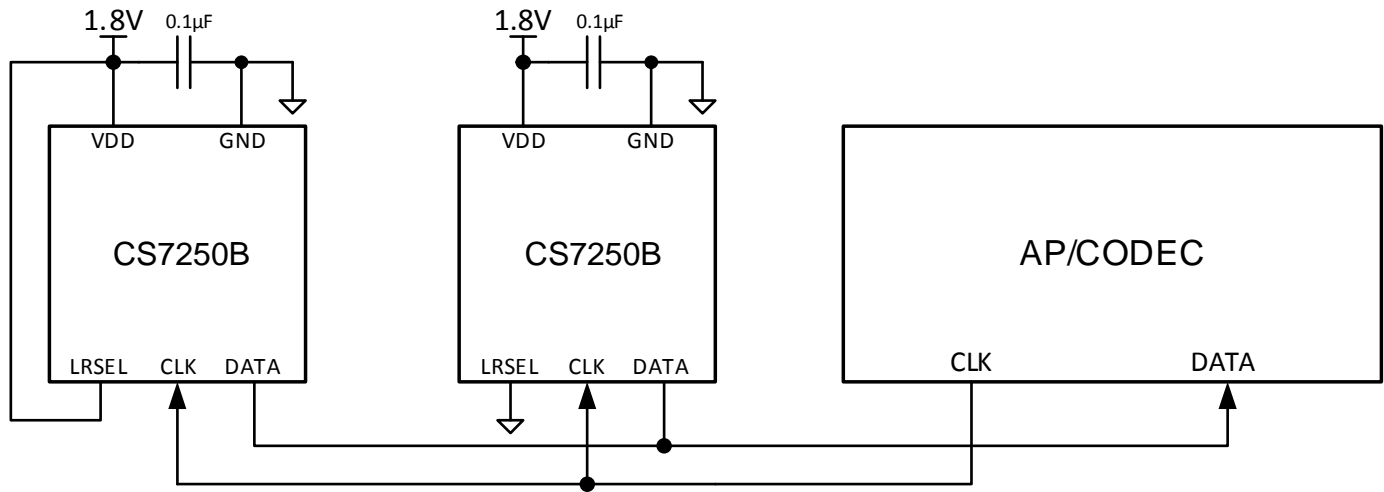

Figure 2-1. Typical Connection Diagram

Stereo connection of two CS7250B digital microphones is shown in [Fig. 2-1](#).

It is recommended to connect a 0.1-µF decoupling capacitor between the VDD and GND pins of the CS7250B. A ceramic 0.1-µF capacitor with X7R dielectric or better is suitable. The capacitor should be placed as close to the CS7250B as possible.

3 Characteristics and Specifications

Table 3-1. Parameter Definitions

Parameter	Definition
Sensitivity	A measure of the microphone output response to the acoustic pressure of a 1-kHz, 94 dB SPL (1 Pa RMS) sine wave. This is referenced to the output Full Scale Range (FSR) of the microphone.
Full Scale Range (FSR)	Sensitivity, electrical noise floor and power supply rejection are measured with reference to the output full scale range (FSR) of the microphone. FSR is defined as the amplitude of a 1-kHz sine-wave output whose positive peak value reaches 100% density of logic 1s and whose negative peak value reaches 0% density of logic 1s. This is the largest 1-kHz sine wave that fits in the digital output range without clipping. Note that, because the definition of FSR is based on a sine wave, it is possible to support a square wave test signal output whose level is +3 dBFS.
Total harmonic distortion (THD)	The ratio of the RMS sum of the harmonic distortion products in the specified bandwidth (see note) relative to the RMS amplitude of the fundamental (i.e., test frequency) output.
Signal-to-noise ratio (SNR)	A measure of the difference in level between the output response of a 1-kHz, 94 dB SPL sine wave and the idle noise output.
Dynamic Range (DR)	The ratio of the 10% THD microphone output level (in response to a sine wave input) and the idle noise output.

Note: Unless otherwise specified, all performance measurements are specified with a low-pass brick-wall filter and, where noted, an A-weighted filter. The low-pass filter removes out-of-band noise.

Table 3-2. Recommended Operating Conditions

Parameter	Symbol	Min	Typ	Max	Units
Supply voltage	VDD	1.62	1.8	1.98	V
Ground	GND	—	0	—	V
Clock frequency	F _{CLK}	0.3	—	3.2	MHz
Operating temperature range	T _A	-40	—	+85	°C

Table 3-3. Absolute Maximum Ratings

Absolute maximum ratings are stress ratings only. Permanent damage to the device may be caused by continuously operating at or beyond these limits. Device functional operating limits and guaranteed performance specifications are given under electrical characteristics at the test conditions specified.

Parameter	Symbol	Min	Max	Units
Supply voltage ¹	VDD	-0.3	2.4	V
Input voltage ¹	V _{IN}	-0.3	2.3 [2]	V
Input current ³	I _{IN}	-10	+10	mA
Operating temperature range	T _A	-40	+105	°C
Storage temperature prior to soldering	T _{Stgp}	—	30	°C
Storage relative humidity prior to soldering	RH _{Stgp}	—	60	%
Storage temperature after soldering	T _{Stg}	-40	+105	°C



ESD-sensitive device. The CS7250B is manufactured on a CMOS process. It is therefore generically susceptible to damage from excessive static voltages. Proper ESD precautions must be taken during handling and storage of this device. This device is qualified to current JEDEC ESD standards

1. All voltages are measured with respect to GND.

2. If VDD is above the minimum recommended operating level (see [Table 3-2](#)), the maximum input voltage is VDD + 0.3 V.

3. Input current is positive when flowing into the device.

Table 3-4. Acoustic and Electrical Characteristics

Test conditions (unless specified otherwise):

 VDD = 1.8 V, GND = 0 V, CLK = 3.072 MHz, T_A = +25°C, 55 ±15% RH, 1-kHz, 94 dB SPL test signal, no load on DATA pin.

Parameter ¹		Min	Typ	Max	Units		
General characteristics	Directivity	Omnidirectional			—		
	Polarity	Positive sound pressure			Increasing density of 1s		
	Sensitivity ²	-37	-36	-35	dBFS		
High Performance Mode (CLK = 3.072 MHz)	Acoustic overload	THD < 10%	—	131	—	dB SPL	
	THD	94 dB SPL	—	0.2	—	%	
		125 dB SPL	—	1	—	%	
	SNR	A-weighted	—	66	—	dB	
	DR	A-weighted	—	103	—	dB	
	Acoustic noise floor	A-weighted	—	28	—	dB SPL	
	Electrical noise floor	A-weighted	—	-102	—	dBFS	
PSR (with respect to VDD)	100 mV p-p, swept sine wave, 20 Hz–20 kHz, A-weighted	—	-90	—	dBFS		
Low Power Mode (CLK = 768 kHz)	Acoustic overload	THD < 10%	—	120	—	dB SPL	
	THD	117 dB SPL	—	1	—	%	
	SNR	20 Hz–8 kHz, A-weighted	—	62	—	dB	
	DR	20 Hz–8 kHz, A-weighted	—	88	—	dB	
	Acoustic noise floor	20 Hz–8 kHz, A-weighted	—	32	—	dB SPL	
	Electrical noise floor	20 Hz–8 kHz, A-weighted	—	-98	—	dBFS	
	PSR (with respect to VDD)	100 mV p-p, swept sine wave, 20 Hz–8 kHz, A-weighted	—	-90	—	dBFS	
Frequency response	Frequency response	-3 dB low frequency	—	35	—	Hz	
		+3 dB high frequency	—	13	—	kHz	
	Frequency response flatness	200 Hz–8 kHz	-1	—	+1	dB	
Digital I/O ³	Input HIGH Level	0.65 × VDD	—	—	—	V	
	Input LOW Level	—	—	0.35 × VDD	—	V	
	Output HIGH Level	I _{OH} = 1 mA	0.9 × VDD	—	—	—	V
	Output LOW Level	I _{OL} = -1 mA	—	—	0.1 × VDD	—	V
	Input capacitance	—	—	3	5	—	pF
	Input leakage	—	-1	—	1	—	μA
	Load capacitance (DATA)	—	—	—	200	—	pF
Miscellaneous characteristics	Current consumption ⁴	High Performance Mode, CLK = 3.072 MHz	—	650	—	—	μA
		Low Power Mode, CLK = 768 kHz	—	160	—	—	μA
		Standby Mode, CLK = 0 Hz	—	5	10	—	—
	Startup time	From power applied to output within 0.5 dB of sensitivity specification	—	15	—	—	ms
	Mode-transition time	From Low Power Mode to High Performance Mode	—	10	—	—	ms
CLK frequency range ^{5,6}	High Performance Mode	—	1.4	—	3.2	—	MHz
		Low Power Mode	300	—	800	—	kHz
		Standby Mode	—	0	—	—	—

1. Performance measurements are specified with a low-pass brick-wall filter and, where noted, an A-weighted filter. The low-pass filter removes out-of-band noise. The Low Power Mode is measured with a cut-off frequency of 8 kHz; all other measurements are with a 20 kHz cut-off frequency.

2. Sensitivity is measured at production test 0.9 s after power up.

3. Note that digital input pins should not be left unconnected or floating.

4. Measured without a load on the DATA pin.

5. High Performance and Low Power Modes are selected according to the CLK frequency.

6. Standby Mode is selected when the CLK input is stopped; this is a power-saving mode. Normal operation resumes automatically when the CLK input frequency is within the specified operational limits. Note that the VDD supply is still required in Standby Mode.

Table 3-5. Audio Interface Timing

The following timing information is valid across the full range of recommended operating conditions.

Parameter 1	Symbol	Min	Typ	Max	Units
CLK cycle time	t_{CY}	313	—	3333	ns
CLK duty cycle	—	60:40	—	40:60	—
CLK rise/fall time	—	—	—	6	ns
DATA enable time	From rising CLK edge, LRSEL = 0	t_{R_EN}	14	—	ns
	From falling CLK edge, LRSEL = 1	t_{L_EN}	14	—	ns
DATA valid time	From rising CLK edge, LRSEL = 0	t_{R_DV}	20	90	ns
	From falling CLK edge, LRSEL = 1	t_{L_DV}	20	90	ns
DATA disable time	From falling CLK edge, LRSEL = 0	t_{R_DIS}	—	10	ns
	From rising CLK edge, LRSEL = 1	t_{L_DIS}	—	10	ns

Notes:

- The DATA output is high-impedance when not outputting data; this enables the outputs of two microphones to be connected together with the data from one microphone interleaved with the data from the other. (The microphones must be configured to transmit on opposite channels in this case.)
- In a typical configuration, the left channel is transmitted following the rising CLK edge (LRSEL = 1). In this case, the left channel should be sampled by the receiving device on the falling CLK edge.
- Similarly, the right channel is typically transmitted following the falling CLK edge (LRSEL = 0). In this case, the right channel should be sampled by the receiving device on the rising CLK edge.
- The CS7250B operating mode is selected according to the CLK frequency; see [Table 3-4](#) for further details.

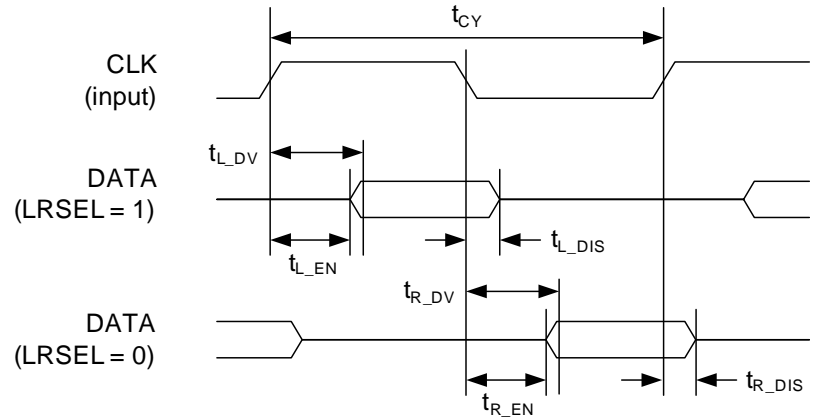
1. Digital microphone interface timing.

DATA is high-impedance (Hi-Z) when not outputting data

4 Typical Performance

4.1 Audio Frequency Response

Test conditions: VDD = 1.8 V, GND = 0 V, CLK = 3.072 MHz, no load on DATA pin.

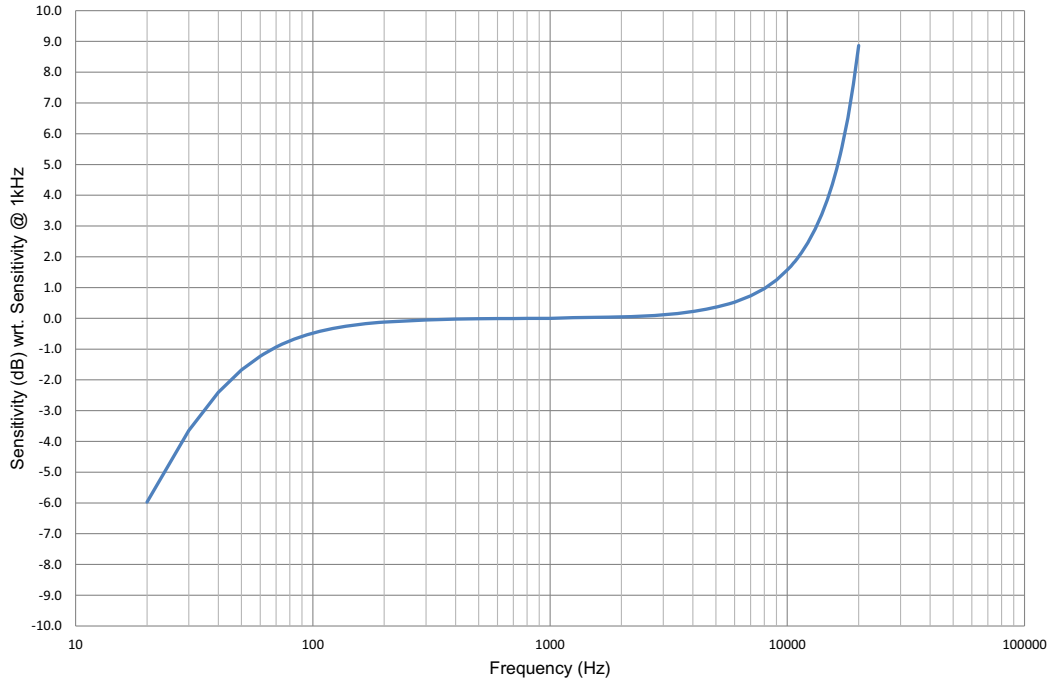

Figure 4-1. Sensitivity vs. Audio Frequency (20 Hz–20 kHz)

4.2 THD Performance

Test conditions: VDD = 1.8 V, GND = 0 V, CLK = 3.072 MHz, no load on DATA pin.

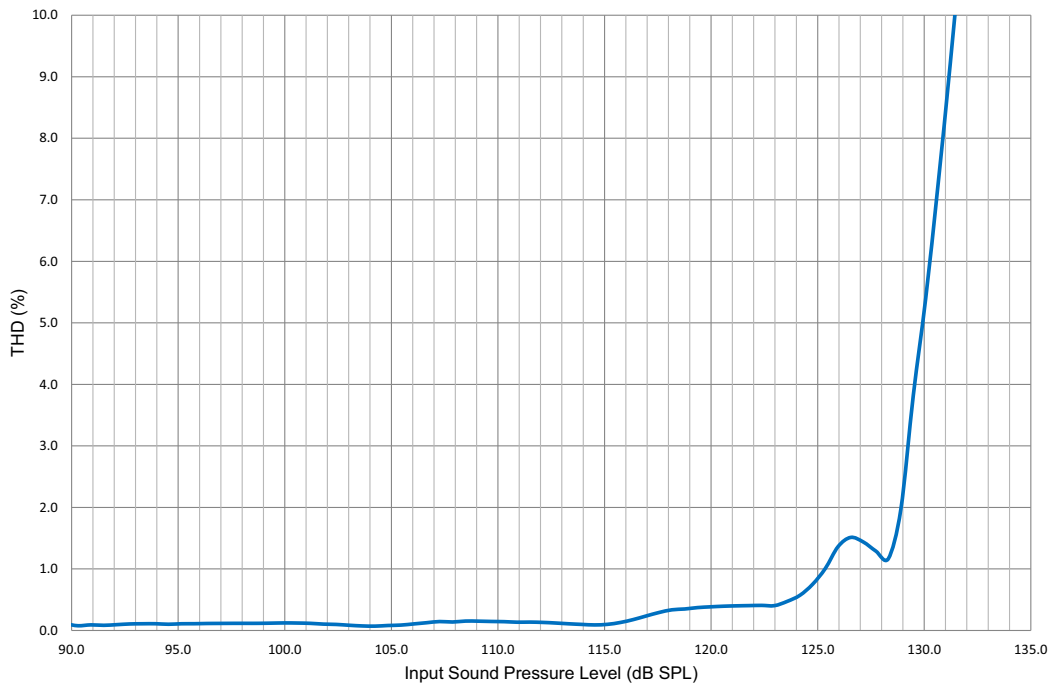

Figure 4-2. THD (%) vs. Input Sound Pressure Level (dB SPL)

5 Applications Information

Cirrus Logic provides a range of audio codecs incorporating a digital microphone input interface; these support direct connection to digital microphones such as the CS7250B.

Further information on Cirrus Logic audio codecs is provided in the respective product data sheet, which is available from the Cirrus Logic website

5.1 Important Assembly Guidelines

- Do not put a vacuum over the port hole of the microphone. Placing a vacuum over the port hole can damage the device.
- Do not board wash the microphone after a reflow process. Board washing and the associated cleaning agents can damage the device.
- Do not expose to ultrasonic cleaning methods.
- Do not use a vapor phase reflow process. The vapor can damage the device.
- Please refer to application note WAN0273 *MEMS Mic Assembly and Handling Guidelines* for further assembly and handling guidelines.

5.2 PCB Land Pattern and Paste Stencil

The recommended PCB land pattern and paste stencil pattern for the CS7250B microphone are shown in [Fig. 5-1](#) and [Fig. 5-2](#) respectively.

See also application note WAN0284 *General Design Considerations for MEMS Microphones* for further details of PCB footprint design. Full definition of the package dimensions is provided in [Section 6](#).

The recommended PCB land pattern is shown in [Fig. 5-1](#).

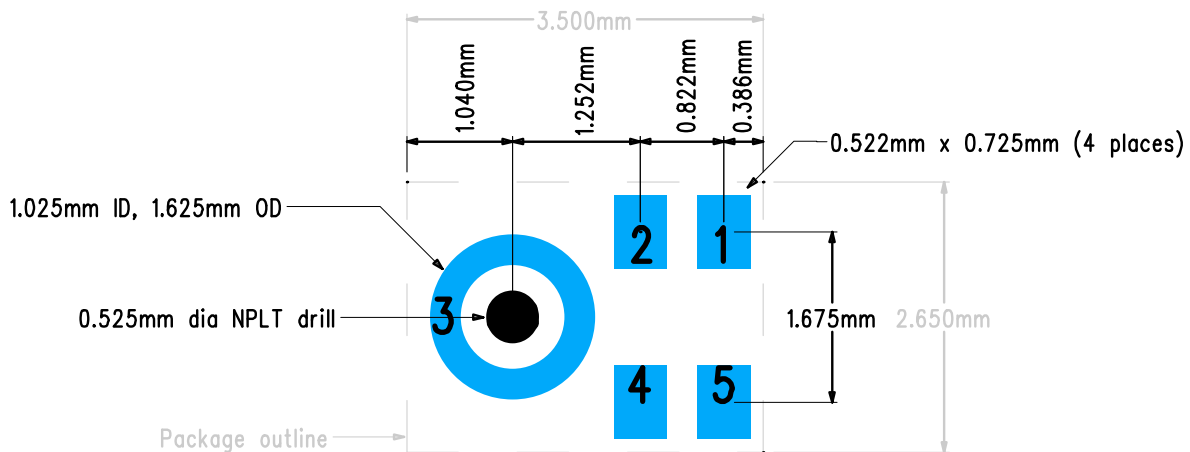

Figure 5-1. PCB Land Pattern, Top View

The recommended PCB paste stencil pattern is shown in Fig. 5-2.

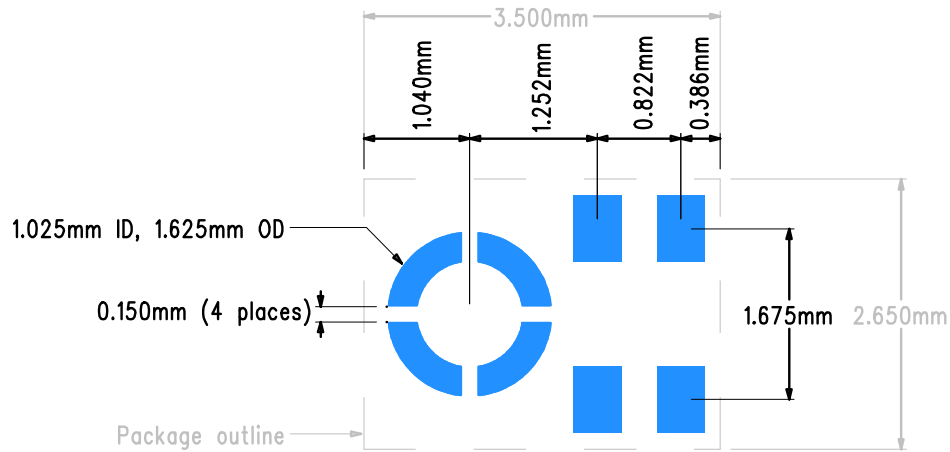
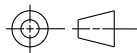
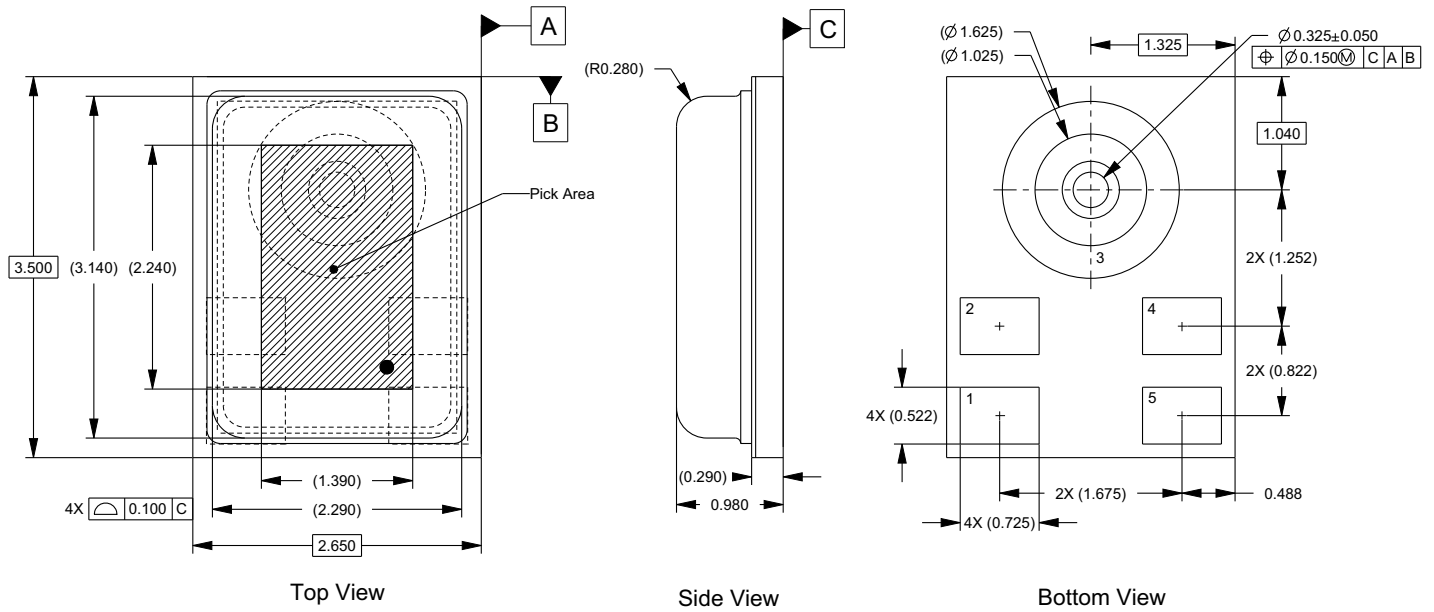

Figure 5-2. PCB Paste Stencil, Top View

6 Package Dimension



Unless otherwise specified, dimensions are in millimeters and tolerance is ± 0.100

7 Ordering Information

Table 7-1. Ordering Information

Product	Description	Package	Halogen Free	Pb Free	Grade	Temperature Range	Container	Order #
CS7250B	Digital MEMS Microphone with High Performance and Low Power Modes	LGA	Yes	Yes	Commercial	-40 to +85°C	Tape and Reel 1	CS7250B-CAZR

1. Reel quantity = 5000

8 References

- WAN0273 *MEMS Mic Assembly and Handling Guidelines*
- WAN0284 *General Design Considerations for MEMS Microphones*

9 Revision History

Table 9-1. Revision History

Revision	Changes
PP1 MAY '17	<ul style="list-style-type: none"> • Clarification of sensitivity specification added (Table 3-4). • THD and frequency-response specifications updated (Table 3-4). • Frequency response plot updated (Section 4.2). • Order quantity updated (Section 7).

Contacting Cirrus Logic Support

For all product questions and inquiries, contact a Cirrus Logic Sales Representative.

To find the one nearest you, go to www.cirrus.com.

IMPORTANT NOTICE

"Preliminary" product information describes products that are in production, but for which full characterization data is not yet available. For the purposes of our terms and conditions of sale, "Preliminary" or "Advanced" data sheets are nonfinal data sheets that include, but are not limited to, data sheets marked as "Target", "Advance", "Product Preview", "Preliminary Technical Data", and/or "Preproduction". Products provided with any such data sheet are therefore subject to relevant terms and conditions associated with "Preliminary" or "Advanced" designations. The products and services of Cirrus Logic International (UK) Limited; Cirrus Logic, Inc.; and other companies in the Cirrus Logic group (collectively either "Cirrus Logic" or "Cirrus") are sold subject to Cirrus Logic's terms and conditions of sale supplied at the time of order acknowledgment, including those pertaining to warranty, indemnification, and limitation of liability. Software is provided pursuant to applicable license terms. Cirrus Logic reserves the right to make changes to its products and specifications or to discontinue any product or service without notice. Customers should therefore obtain the latest version of relevant information from Cirrus Logic to verify that the information is current and complete. Testing and other quality control techniques are utilized to the extent Cirrus Logic deems necessary. Specific testing of all parameters of each device is not necessarily performed. In order to minimize risks associated with customer applications, the customer must use adequate design and operating safeguards to minimize inherent or procedural hazards. Cirrus Logic is not liable for applications assistance or customer product design. The customer is solely responsible for its selection and use of Cirrus Logic products. Use of Cirrus Logic products may entail a choice between many different modes of operation, some or all of which may require action by the user, and some or all of which may be optional. Nothing in these materials should be interpreted as instructions or suggestions to choose one mode over another. Likewise, description of a single mode should not be interpreted as a suggestion that other modes should not be used or that they would not be suitable for operation. Features and operations described herein are for illustrative purposes only.

CERTAIN APPLICATIONS USING SEMICONDUCTOR PRODUCTS MAY INVOLVE POTENTIAL RISKS OF DEATH, PERSONAL INJURY, OR SEVERE PROPERTY OR ENVIRONMENTAL DAMAGE ("CRITICAL APPLICATIONS"). CIRRUS LOGIC PRODUCTS ARE NOT DESIGNED, AUTHORIZED OR WARRANTED FOR USE IN PRODUCTS SURGICALLY IMPLANTED INTO THE BODY, AUTOMOTIVE SAFETY OR SECURITY DEVICES, NUCLEAR SYSTEMS, LIFE SUPPORT PRODUCTS OR OTHER CRITICAL APPLICATIONS. INCLUSION OF CIRRUS LOGIC PRODUCTS IN SUCH APPLICATIONS IS UNDERSTOOD TO BE FULLY AT THE CUSTOMER'S RISK AND CIRRUS LOGIC DISCLAIMS AND MAKES NO WARRANTY, EXPRESS, STATUTORY OR IMPLIED, INCLUDING THE IMPLIED WARRANTIES OF MERCHANTABILITY AND FITNESS FOR PARTICULAR PURPOSE, WITH REGARD TO ANY CIRRUS LOGIC PRODUCT THAT IS USED IN SUCH A MANNER. IF THE CUSTOMER OR CUSTOMER'S CUSTOMER USES OR PERMITS THE USE OF CIRRUS LOGIC PRODUCTS IN CRITICAL APPLICATIONS, CUSTOMER AGREES, BY SUCH USE, TO FULLY INDEMNIFY CIRRUS LOGIC, ITS OFFICERS, DIRECTORS, EMPLOYEES, DISTRIBUTORS AND OTHER AGENTS FROM ANY AND ALL LIABILITY, INCLUDING ATTORNEYS' FEES AND COSTS, THAT MAY RESULT FROM OR ARISE IN CONNECTION WITH THESE USES.

This document is the property of Cirrus Logic and by furnishing this information, Cirrus Logic grants no license, express or implied, under any patents, mask work rights, copyrights, trademarks, trade secrets or other intellectual property rights. Any provision or publication of any third party's products or services does not constitute Cirrus Logic's approval, license, warranty or endorsement thereof. Cirrus Logic gives consent for copies to be made of the information contained herein only for use within your organization with respect to Cirrus Logic integrated circuits or other products of Cirrus Logic, and only if the reproduction is without alteration and is accompanied by all associated copyright, proprietary and other notices and conditions (including this notice). This consent does not extend to other copying such as copying for general distribution, advertising or promotional purposes, or for creating any work for resale. This document and its information is provided "AS IS" without warranty of any kind (express or implied). All statutory warranties and conditions are excluded to the fullest extent possible. No responsibility is assumed by Cirrus Logic for the use of information herein, including use of this information as the basis for manufacture or sale of any items, or for infringement of patents or other rights of third parties. Cirrus Logic, Cirrus, the Cirrus Logic logo design, and SoundClear are among the trademarks of Cirrus Logic. Other brand and product names may be trademarks or service marks of their respective owners.

Copyright © 2015–2017 Cirrus Logic, Inc. All rights reserved.