

## N-Channel Trench Power MOSFET

### General Description

The CS8205 uses advanced trench technology to provide excellent  $R_{DS(ON)}$ , low gate charge and operation with gate voltages as low as 2.5V. This device is suitable for use as a Battery protection or in other Switching applications.

### Features

- $V_{DS} = 20V, I_D = 4.2A$   
 $R_{DS(ON)} < 26m\Omega @ V_{GS} = 4.5V$   
 $R_{DS(ON)} < 36m\Omega @ V_{GS} = 2.5V$
- High Power and current handling capability
- Lead free product is acquired
- Surface Mount Package

### Application

- Battery protection
- Load switch
- Power management

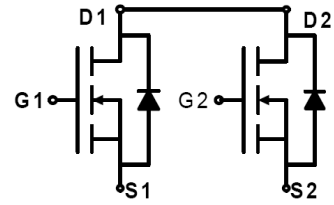

Schematic Diagram

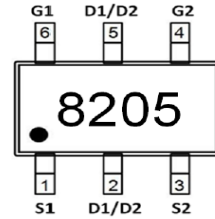

Marking and pin Assignment

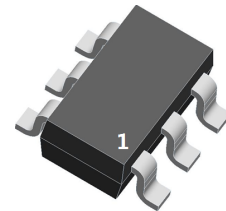

SOT23-6 top view

### Package Marking and Ordering Information

Device Marking	Device	Device Package	Reel Size	Tape width	Quantity
8205	CS8205	SOT23-6	Ø180mm	8mm	3000 units

Table 1. Absolute Maximum Ratings ( $T_A = 25^\circ C$ )

Symbol	Parameter	Value	Unit
$V_{DS}$	Drain-Source Voltage ( $V_{GS} = 0V$ )	20	V
$V_{GS}$	Gate-Source Voltage ( $V_{DS} = 0V$ )	$\pm 10$	V
$I_D$	Drain Current-Continuous	4.2	A
$I_{DM (pluse)}$	Drain Current-Continuous@ Current-Pulsed (Note 1)	25	A
$P_D$	Maximum Power Dissipation	1.25	W
$T_J, T_{STG}$	Operating Junction and Storage Temperature Range	-55 To 150	$^\circ C$

Notes 1. Repetitive Rating: Pulse width limited by maximum junction temperature

Table 2. Thermal Characteristic

Symbol	Parameter	Value	Unit
$R_{\theta JA}$	Thermal Resistance, Junction-to-Ambient	100	$^\circ C/W$

**Table 3. Electrical Characteristics (TA=25°C unless otherwise noted)**

Symbol	Parameter	Conditions	Min	Typ	Max	Unit
<b>On/Off States</b>						
BV <sub>DSS</sub>	Drain-Source Breakdown Voltage	V <sub>GS</sub> =0V, I <sub>D</sub> =250μA	20	21.5		V
I <sub>DSS</sub>	Zero Gate Voltage Drain Current	V <sub>DS</sub> =19.5V, V <sub>GS</sub> =0V			1	μA
I <sub>GSS</sub>	Gate-Body Leakage Current	V <sub>GS</sub> =±10V, V <sub>DS</sub> =0V			±100	nA
V <sub>GS(th)</sub>	Gate Threshold Voltage	V <sub>DS</sub> =V <sub>GS</sub> , I <sub>D</sub> =250μA	0.5	0.65	1.1	V
g <sub>FS</sub>	Forward Transconductance	V <sub>DS</sub> =5V, I <sub>D</sub> =4.2A	4	10		S
R <sub>DS(ON)</sub>	Drain-Source On-State Resistance	V <sub>GS</sub> =4.5V, I <sub>D</sub> =4.2A		18	26	mΩ
		V <sub>GS</sub> =2.5V, I <sub>D</sub> =3A		24	36	mΩ
<b>Dynamic Characteristics</b>						
C <sub>iss</sub>	Input Capacitance	V <sub>DS</sub> =8V, V <sub>GS</sub> =0V, f=1.0MHz		605		pF
C <sub>oss</sub>	Output Capacitance			315		pF
C <sub>rss</sub>	Reverse Transfer Capacitance			132		pF
<b>Switching Times</b>						
t <sub>d(on)</sub>	Turn-on Delay Time	V <sub>DD</sub> =10V, I <sub>D</sub> =1A, V <sub>GS</sub> =4.5V, R <sub>G</sub> =6Ω		11		nS
t <sub>r</sub>	Turn-on Rise Time			12		nS
t <sub>d(off)</sub>	Turn-Off Delay Time			36		nS
t <sub>f</sub>	Turn-Off Fall Time			32		nS
Q <sub>g</sub>	Total Gate Charge	V <sub>DS</sub> =10V, I <sub>D</sub> =4A, V <sub>GS</sub> =4.5V		10		nC
Q <sub>gs</sub>	Gate-Source Charge			2.8		nC
Q <sub>gd</sub>	Gate-Drain Charge			1.8		nC
<b>Source-Drain Diode Characteristics</b>						
I <sub>SD</sub>	Source-Drain Current(Body Diode)				1.7	A
V <sub>SD</sub>	Forward on Voltage <sup>(Note 1)</sup>	V <sub>GS</sub> =0V, I <sub>S</sub> =1.7A		0.79	1.2	V

Notes 1. Repetitive Rating: Pulse width limited by maximum junction temperature.

**Switch Time Test Circuit and Switching Waveforms:**

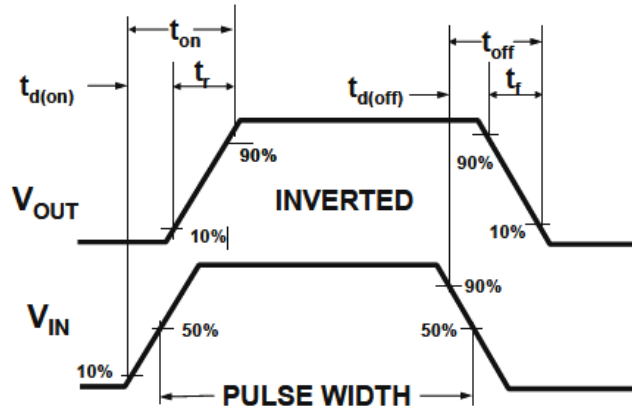
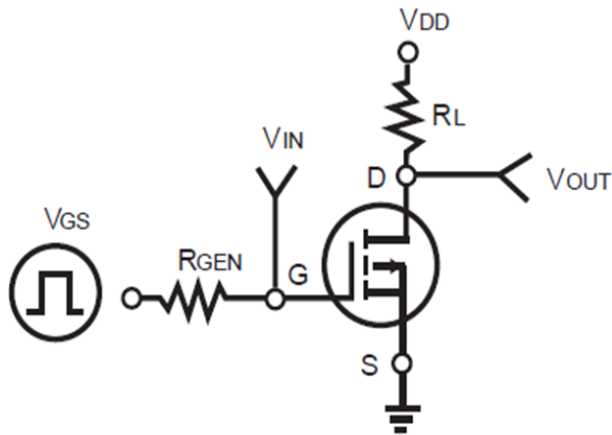

**TYPICAL ELECTRICAL AND THERMAL CHARACTERISTICS (Curves)**

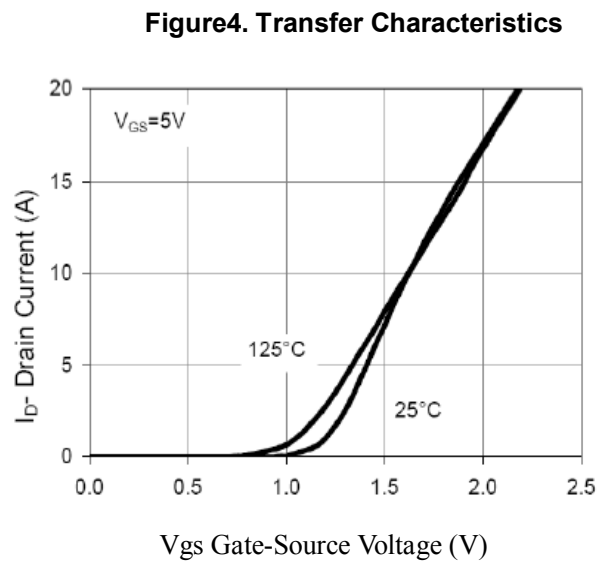
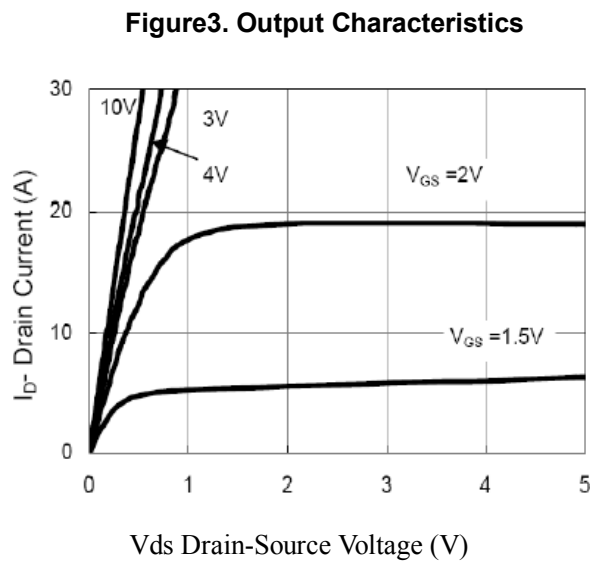
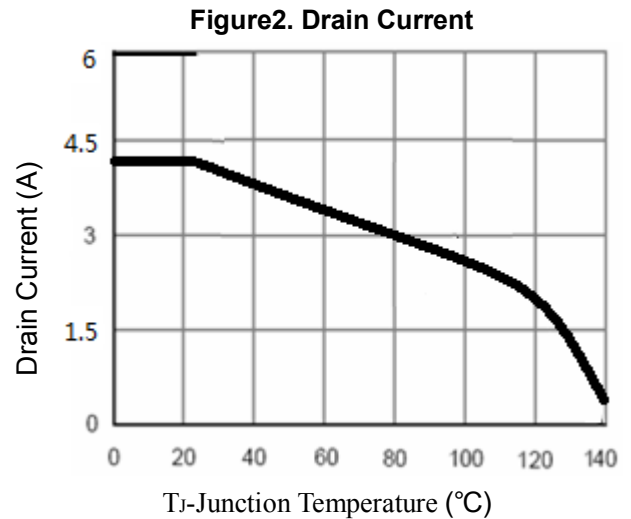
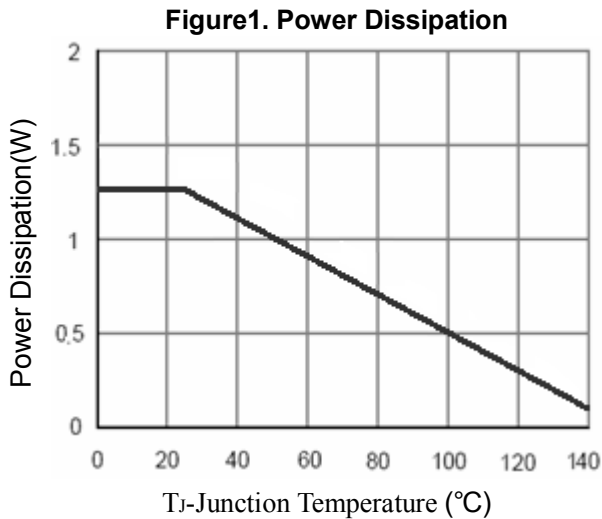

**Figure5. Capacitance**

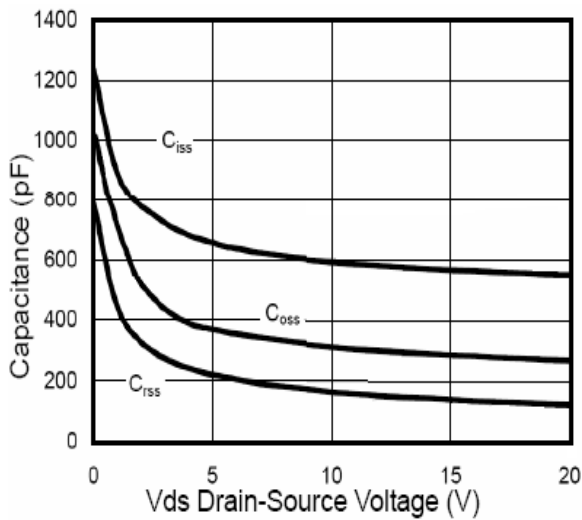

**Figure6.  $R_{DS(ON)}$  vs Junction Temperature**

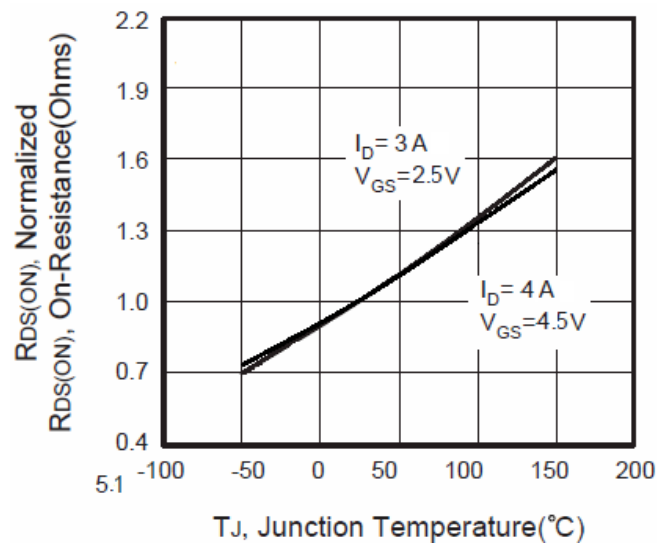

**Figure7. Max  $BV_{DSS}$  vs Junction Temperature**

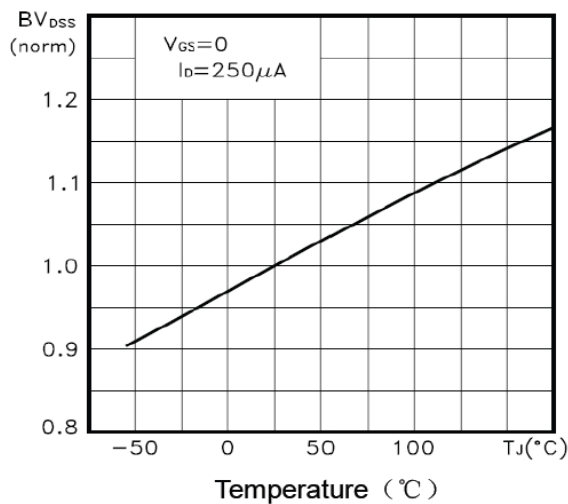

**Figure8.  $V_{GS(th)}$  vs Junction Temperature**

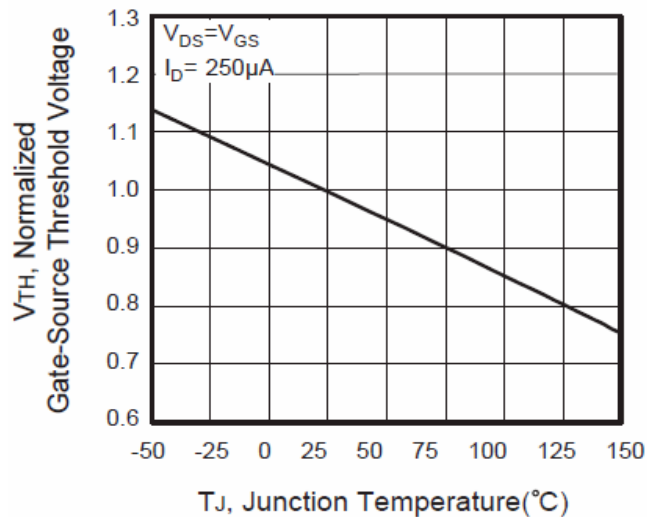

**Figure9. Gate Charge Waveforms**

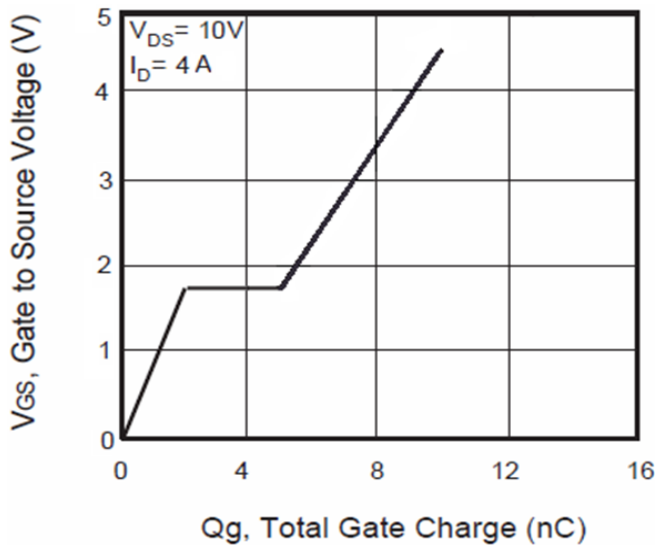

**Figure10. Maximum Safe Operating Area**

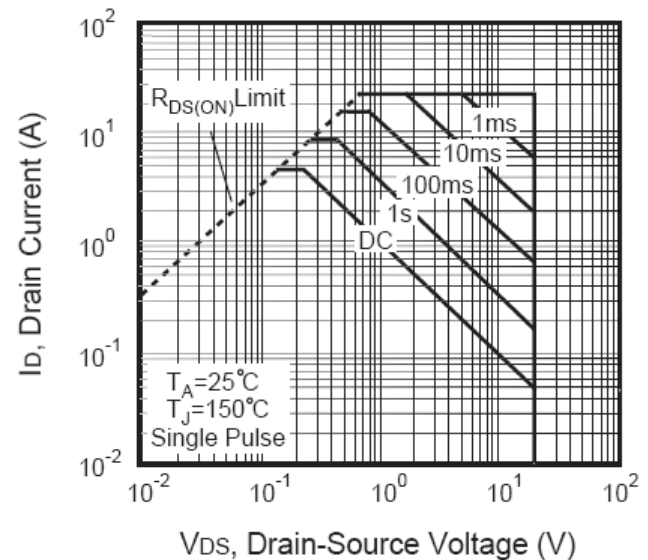
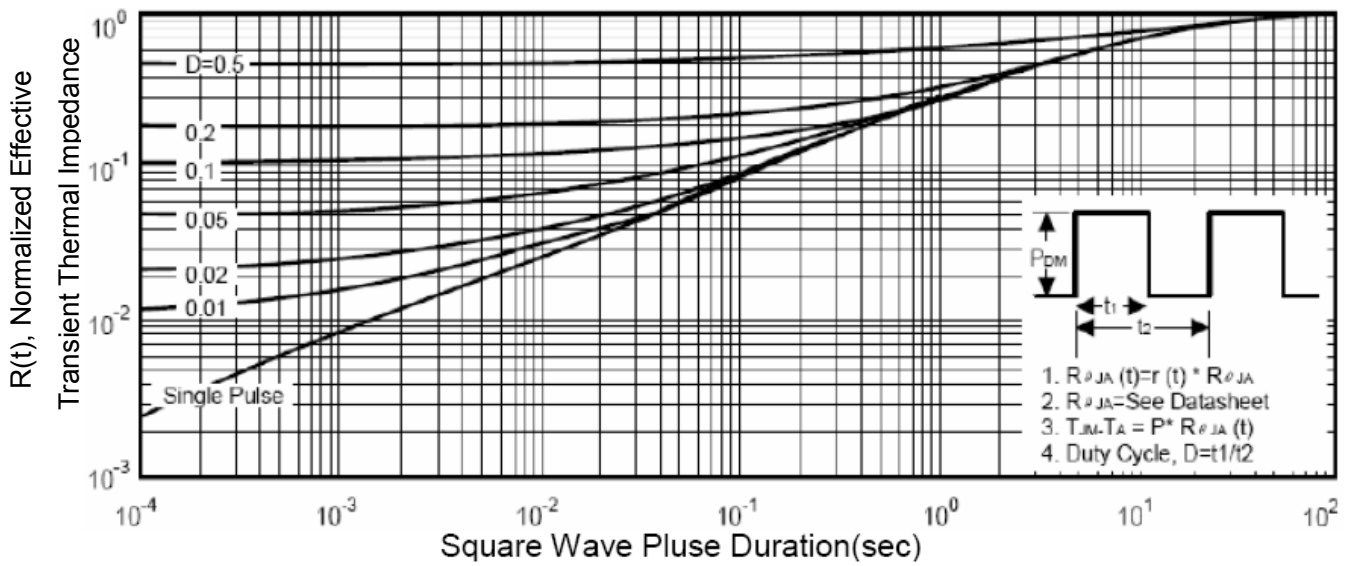
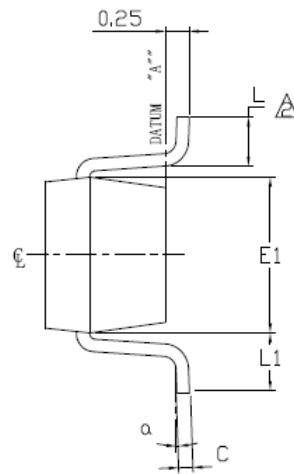
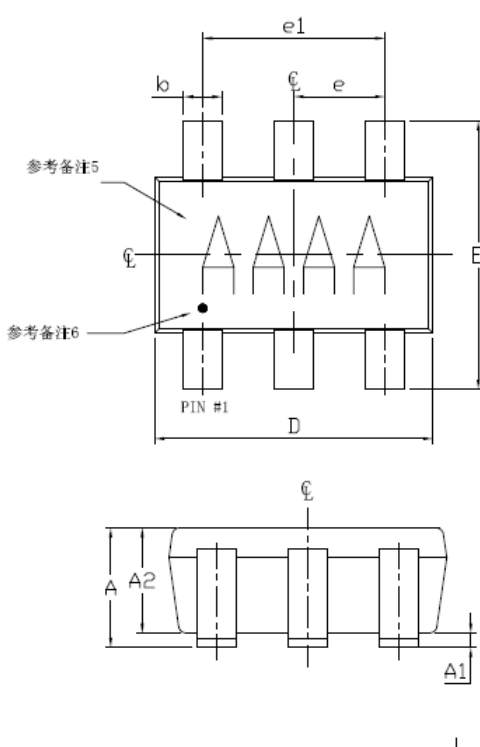

Figure11. Normalized Maximum Transient Thermal Impedance



## SOT23-6 Package Information



SYMBOL	MIN	NOM	MAX
A	0.90	1.25	1.45
A1	0.00	0.05	0.15
A2	0.90	1.10	1.30
b	0.35	0.40	0.50
C	0.08	0.15	0.20
D	2.80	2.90	3.00
E	2.60	2.80	3.00
E1	1.50	1.625	1.75
L	0.35	0.45	0.60
L1	0.60 REF.		
e1	1.90 BSC.		
e	0.95 BSC.		
a	0°	2.5°	8°

PKG CODES:  
 U6-1, U6-2, U6-4, U6CN-2,  
 U6SN-1, U6F-6, U6FH-6

备注:

1. 标注单位:MM.
2. 引脚长度的测量点为引脚与塑封体接触点及引脚边缘最长处。
3. 塑封体测量尺寸不包括毛刺及金属毛刺, 另塑封体毛刺及金属毛刺长度不超过0.25mm.
4. 引脚平面度控制小于0.1mm.
5. 印字面向上进行读取时, PIN1 位于左下方 (参考图解).
6. PIN1的标记最小为 $\varnothing$ 0.3mm, 并位于PIN1脚位上方.
7. 考文献: JEDECT0236-VARIATION AB.