

## 100mΩ Power Distribution Switches

### General Description

The CS9729 is an integrated 100mΩ power switch for self-powered and bus-powered Universal Serial Bus (USB) applications. A built-in charge pump is used to drive the N-MOSFET that is free of parasitic body diode to eliminate any reversed current flow across the switch when it is powered off. Its low quiescent current (23μA) and small package (SOT-23-5) is particularly suitable in battery-powered portable equipment.

Several protection functions include soft start to limit inrush current during plug-in, current limiting at 1.5A to meet USB power requirement, and thermal shutdown to protect damage under over current conditions.

### Ordering Information

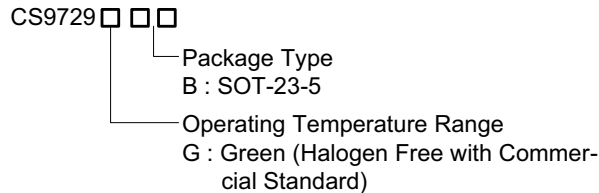

Note :

Richtek Green products are :

- ▶ RoHS compliant and compatible with the current requirements of IPC/JEDEC J-STD-020.
- ▶ Suitable for use in SnPb or Pb-free soldering processes.

### Marking Information

For marking information, contact our sales representative directly or through a Richtek distributor located in your area, otherwise visit our website for detail.

### Features

- 100mΩ Typ. High-Side N-MOSFET
- Guaranteed 1.1A Continuous Current
- 1.5A Current Limit
- Small SOT-23-5 Package Minimizes Board Space
- Soft Start
- Thermal Protection
- Low 23μA Supply Current
- Wide Input Voltage Range : 2.2V to 6V
- UL Approved - #E219878
- RoHS Compliant and Halogen Free

### Applications

- Battery-Powered Equipment
- Motherboard USB Power Switch
- USB Device Power Switch
- Hot-Plug Power Supplies
- Battery-Charger Circuits

### Pin Configurations

(TOP VIEW)

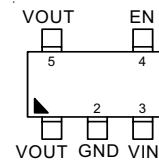

SOT-23-5

### Typical Application Circuit

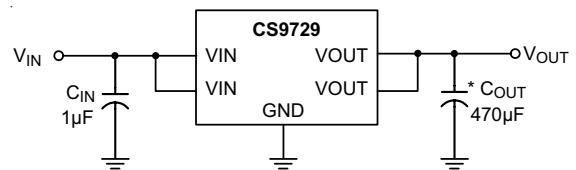

\* 470uF, Low ESR Electrolytic

## Test Circuits

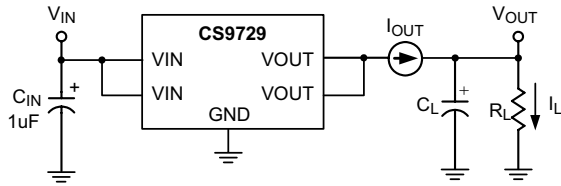

Test Circuit 1

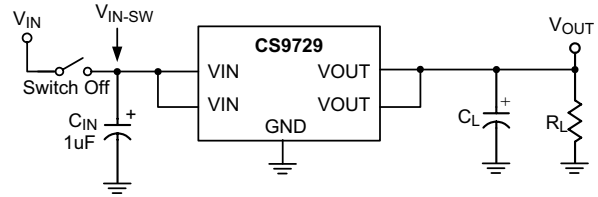

Test Circuit 2

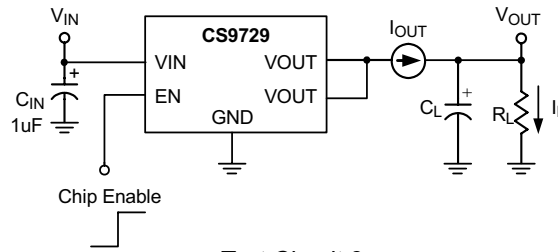

Test Circuit 3

Test Circuit 2 is performed by charging an external tank of bulk capacitor to the input then applying this voltage to the input of the unit.

All typical operating characteristics curves showed are referred to Test Circuit 1, unless specified to Test Circuit 2 or Test Circuit 3.

## Functional Pin Description

Pin Name	Pin Function
VIN	Power Input Voltage.
VOUT	Output Voltage.
GND	Ground.
EN	Chip Enable (Active High).

## Function Block Diagram

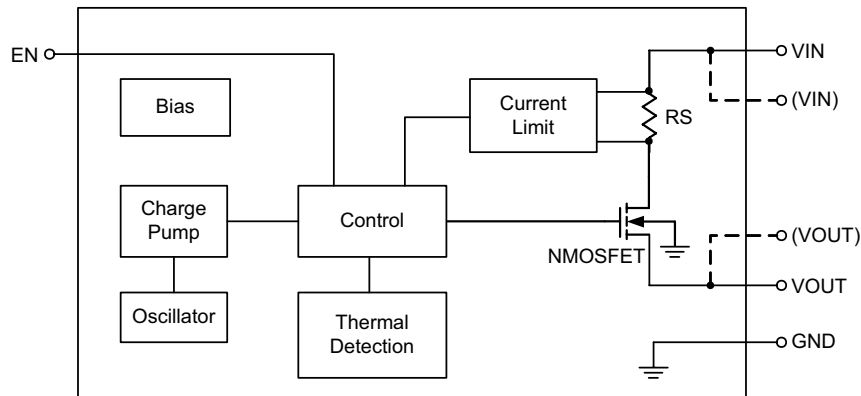

**Absolute Maximum Ratings**

- Supply Voltage ----- 7V
- Chip Enable ----- -0.3V to 7V
- Power Dissipation,  $P_D @ T_A = 25^\circ\text{C}$   
   SOT-23-5 ----- 0.25W
- Package Thermal Resistance  
   SOT-23-5,  $\theta_{JA}$  ----- 250°C/W
- Lead Temperature (Soldering, 10 sec.) ----- 260°C
- Operating Junction Temperature Range ----- -20°C to 100°C
- Storage Temperature Range ----- -65°C to 150°C
- $V_{OUT}$  ESD Level  
   HBM (Human Body Mode) ----- 8kV  
   MM (Machine Mode) ----- 800V

**Electrical Characteristics**

( $V_{IN} = 5V$ ,  $C_{IN} = C_{OUT} = 1\mu\text{F}$ ,  $T_A = 25^\circ\text{C}$ , unless otherwise specified)

Parameter		Symbol	Test Conditions	Min	Typ	Max	Units
Input Voltage Range		$V_{IN}$		2.2	--	6	V
Output N-MOSFET $R_{DS(ON)}$		$R_{DS(ON)}$	$I_L = 1A$	--	87	100	mΩ
Quiescent Current			$V_{IN} = 3V$	--	19	40	μA
			$V_{IN} = 5V$	--	23	45	
Output Turn-On Rising Time		$T_R$	$R_L = 10\Omega$ , 90% Settling	--	400	--	μs
Current Limit Threshold		$I_{LIM}$	$R_L = 2\Omega$	1.1	1.5	2	A
Short-circuit Fold Back Current		$I_{OS}$	$V_{OUT} = 0V$ , measured prior to thermal shutdown	--	1.0	--	A
EN Threshold	Logic-High Voltage	$V_{IH}$		2	--	--	V
	Logic-Low Voltage	$V_{IL}$		--	--	0.8	V
Shutdown Supply Current		$I_{OFF}$	EN = "0"	--	0.1	1	μA
Output Leakage Current		$I_{LEAKAGE}$	EN = "0", $V_{OUT} = 0V$	--	0.5	10	μA
$V_{IN}$ Under Voltage Lockout		UVLO		1.3	1.8	--	V
$V_{IN}$ Under Voltage Hysteresis				--	100	--	mV
Thermal Limit		$T_{SD}$		--	130	--	°C
Thermal Limit Hysteresis		$\Delta T_{SD}$		--	20	--	°C

Typical Operating Characteristics

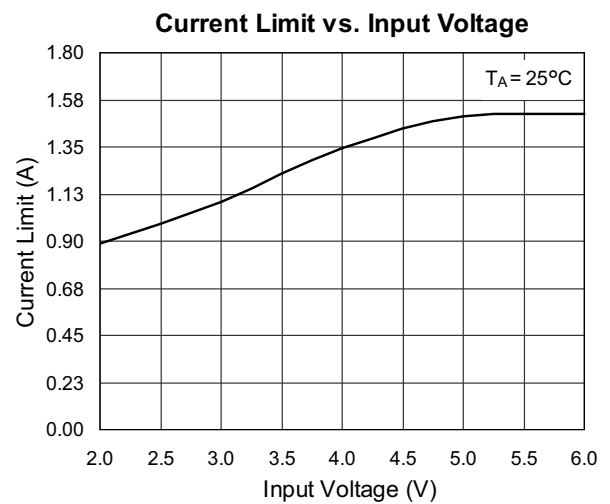
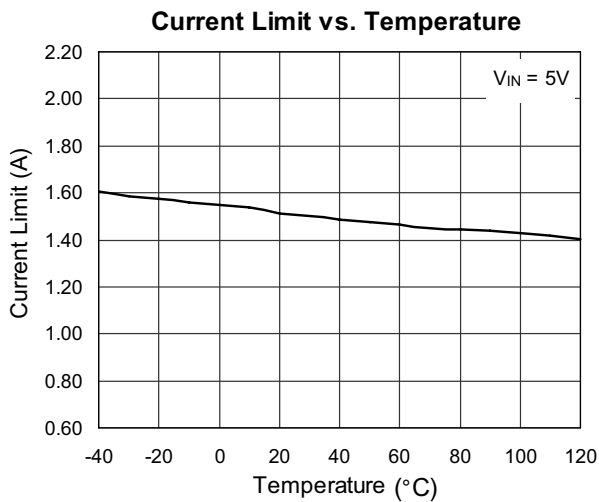
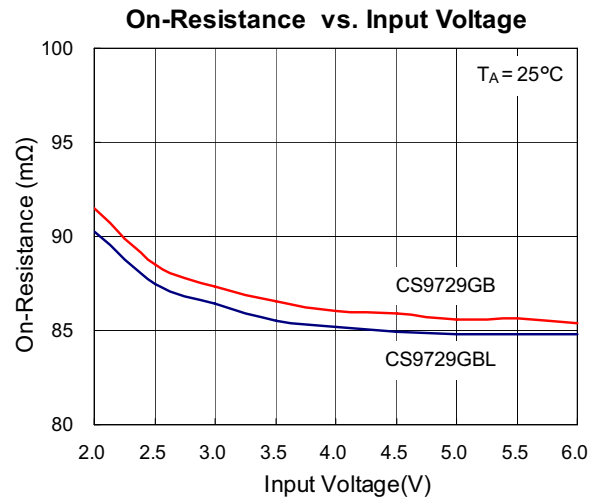
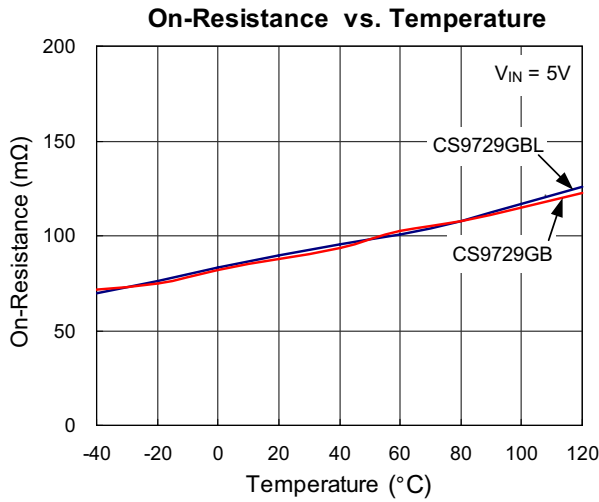
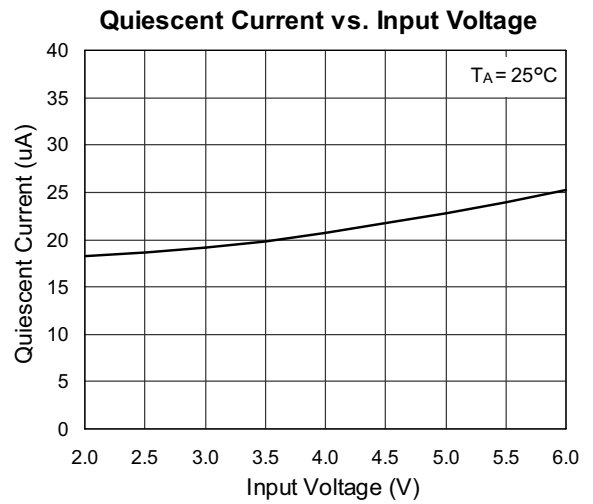
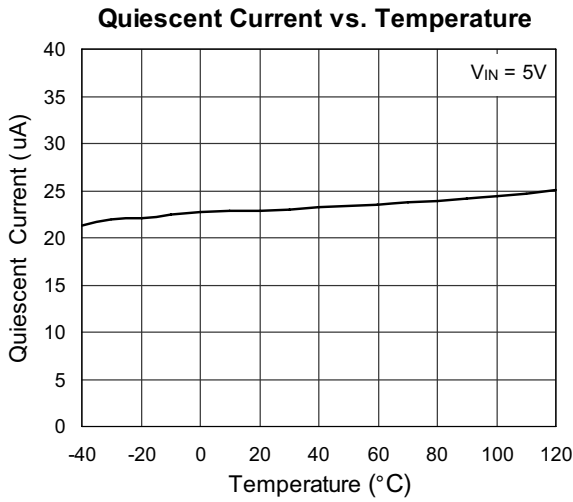

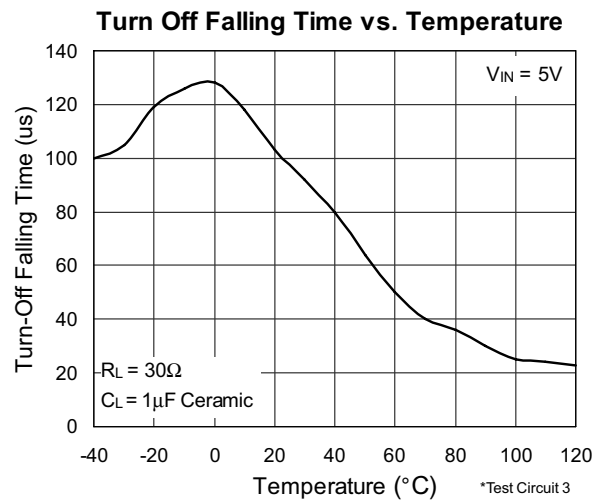
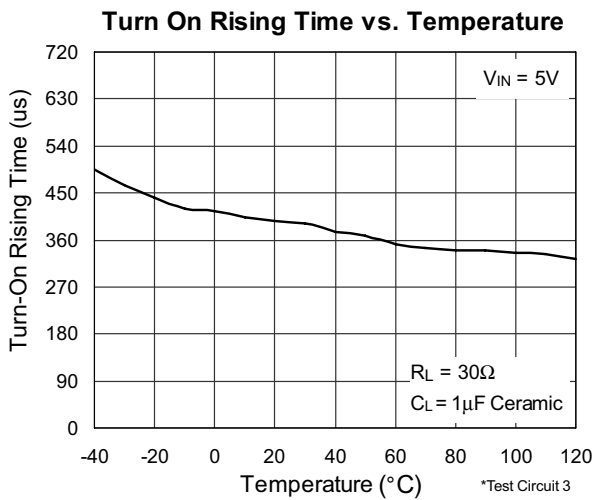
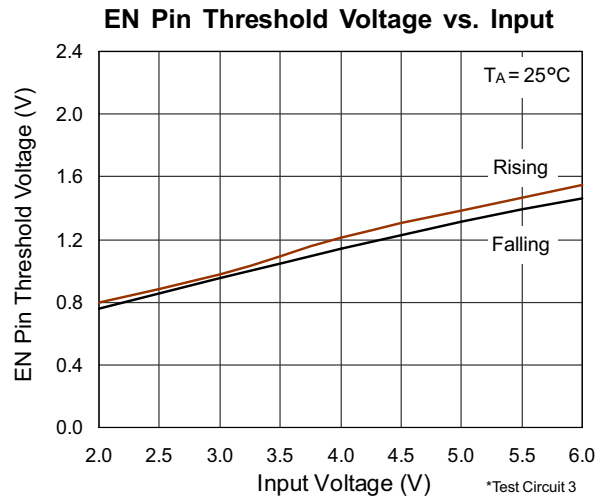
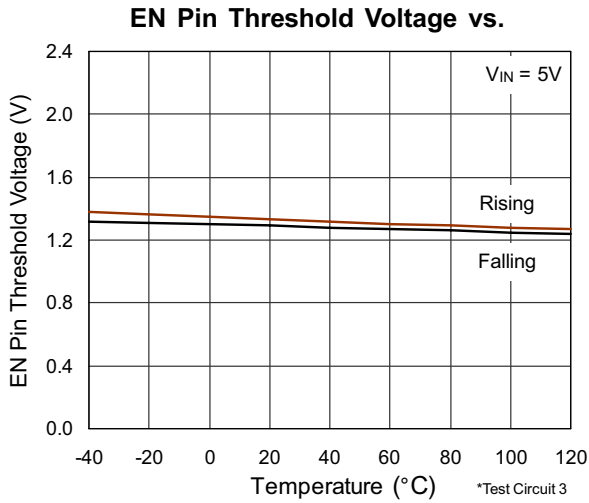
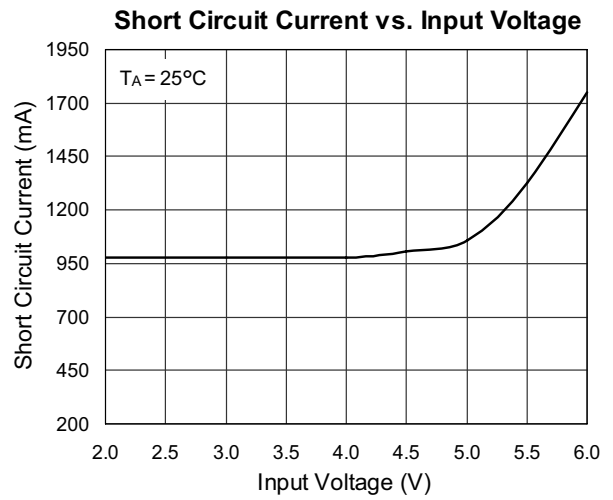
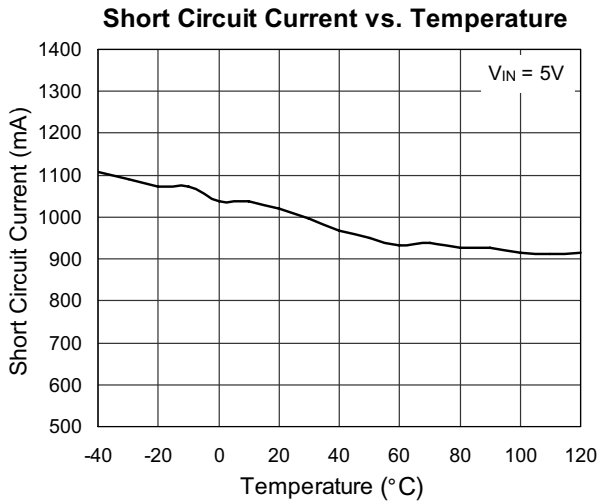

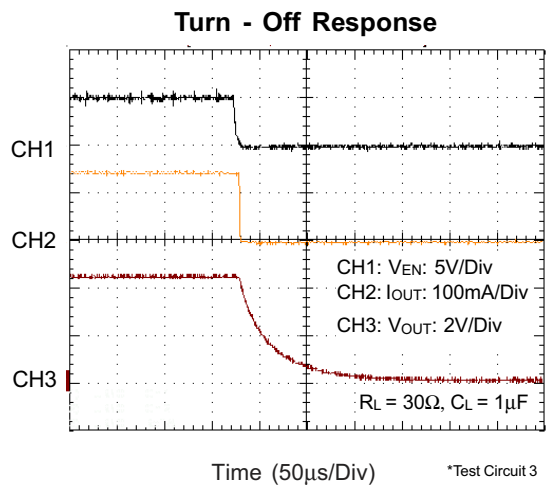
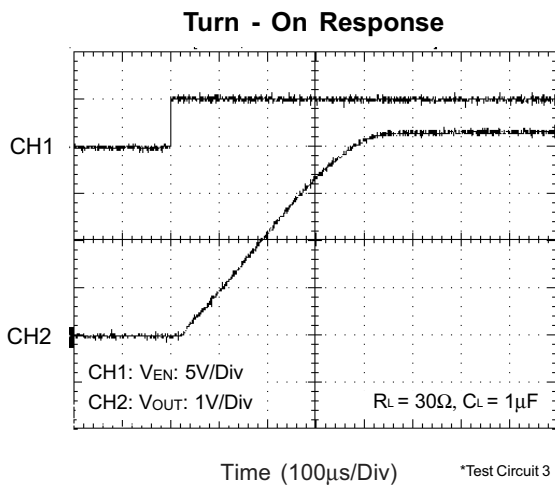
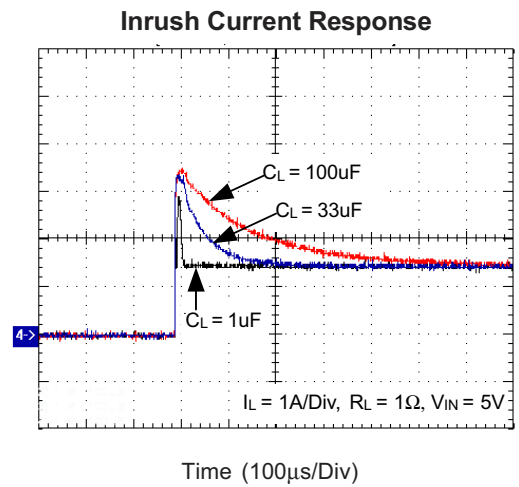
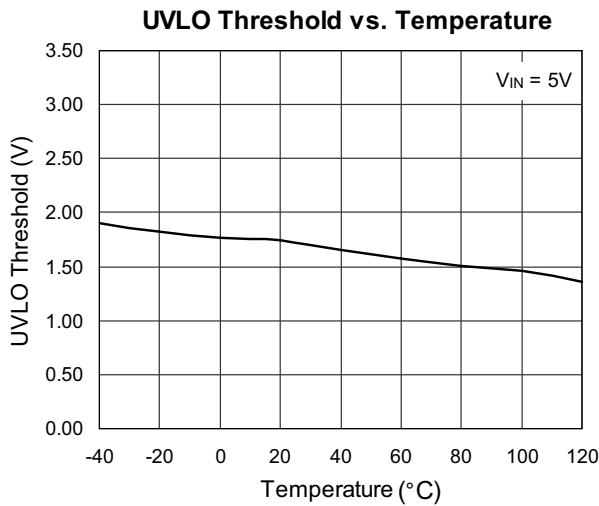
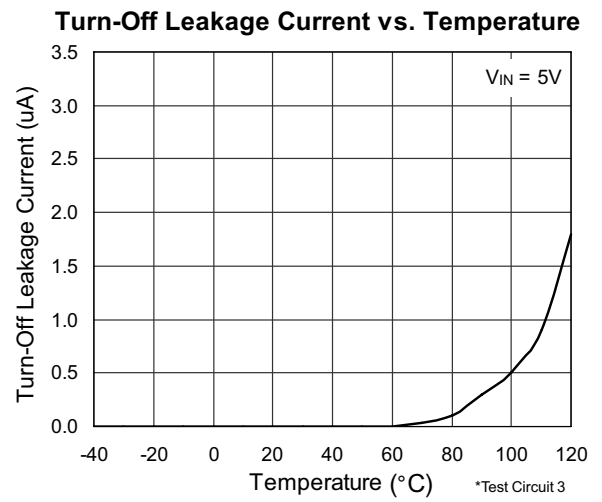
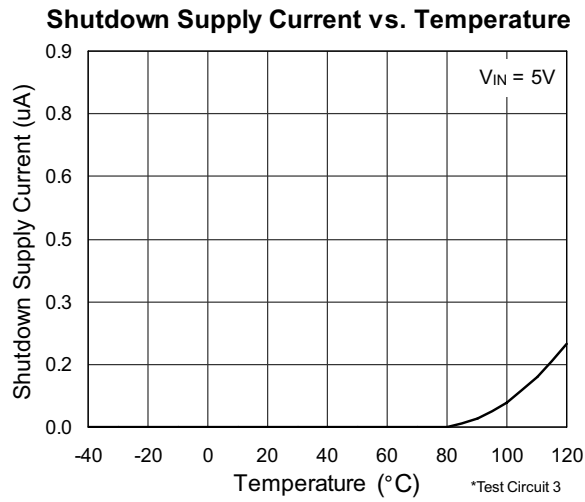

**UVLO at Rising**

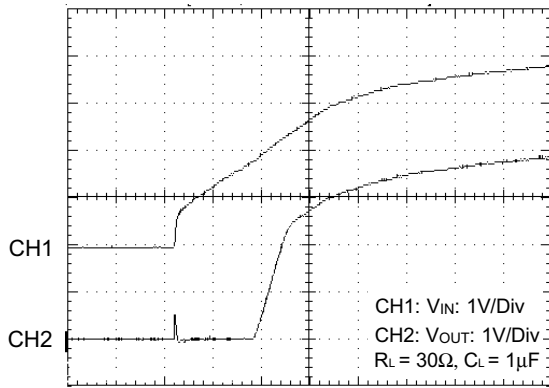

Time (500 $\mu$ s/Div)

**UVLO at Falling**

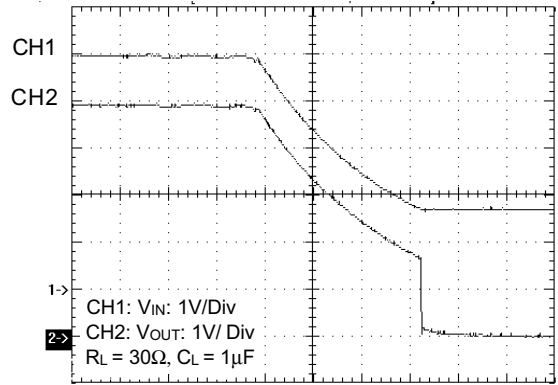

Time (100ms/Div)

\*Test Circuit 2

**Inrush Short Circuit Response**

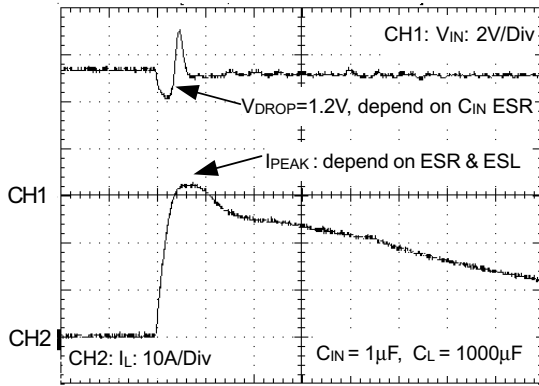

Time (25 $\mu$ s/Div)

**Soft - start Short Circuit Response**

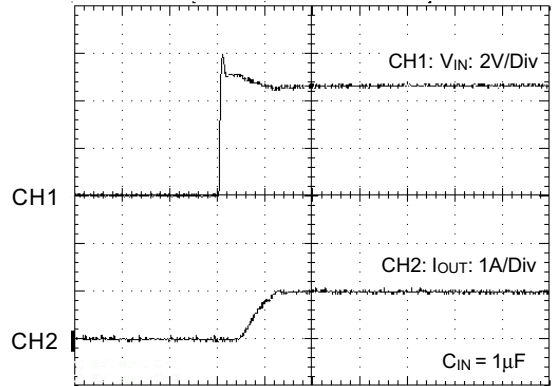

Time (5 $\mu$ s/Div)

**Ramped Load Response**

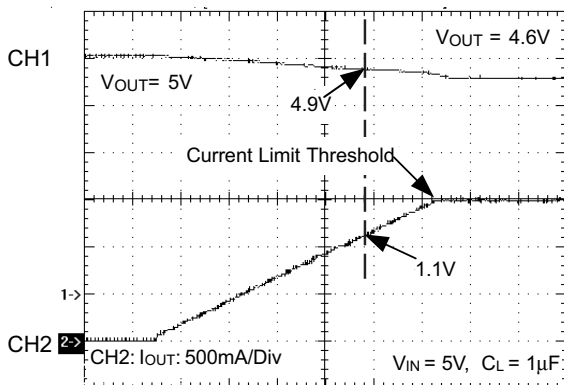

Time (1ms/Div)

**Current Limit Response**

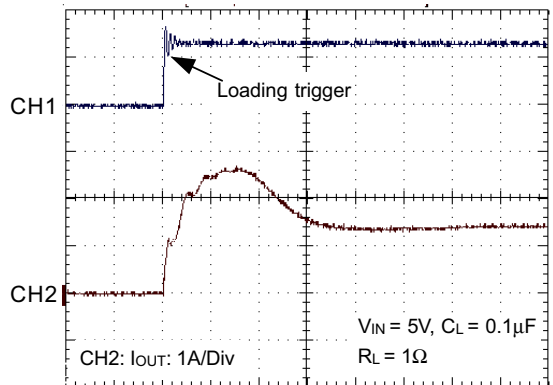

Time (5 $\mu$ s/Div)

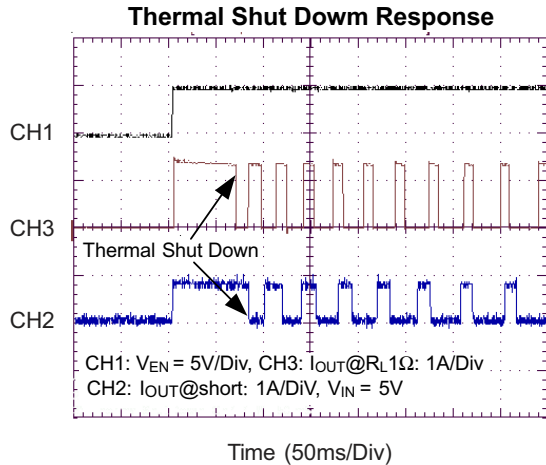

### Application Information

The CS9729 is a high-side single N-MOSFET switch with active-high enable input.

#### Input and Output

V<sub>IN</sub> (input) is the power supply connection to the circuitry and the drain of the output MOSFET. V<sub>OUT</sub> (output) is the source of the output MOSFET. In a typical circuit, current flows through the switch from V<sub>IN</sub> to V<sub>OUT</sub> toward the load. Both V<sub>OUT</sub> pins must be short on the board and connected to the load and so do both V<sub>IN</sub> pins but connected to the power source.

#### Thermal Shutdown

Thermal shutdown shuts off the output MOSFET if the die temperature exceeds 130°C and 20°C of hysteresis forces the switch turning off until the die temperature drops to 110°C.

#### Soft Start

In order to eliminate the upstream voltage droop caused by the large inrush current during hot-plug events, the “soft-start” feature effectively isolates power supplies from such highly capacitive loads.

#### Under-voltage Lockout

UVLO prevents the MOSFET switch from turning on until input voltage exceeds 1.8V (typical). If input voltage drops below 1.8V (typical), UVLO shuts off the MOSFET switch.

### Current Limiting and Short Protection

The current limit circuit is designed to protect the system supply, the MOSFET switch and the load from damage caused by excessive currents. The current limit threshold is set internally to allow a minimum of 1.1A through the MOSFET but limits the output current to approximately 1.5A typical. When the output is short to ground, it will limit to a constant current 1A until thermal shutdown or short condition removed.

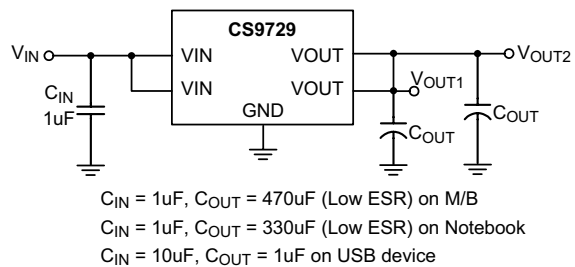

Figure 1. High Side Power Switch

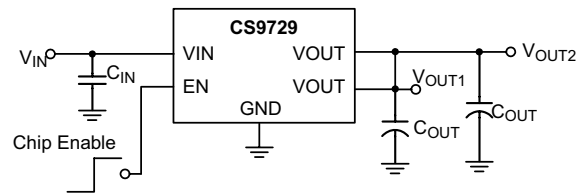

Figure 2. High Side Power Switch with Chip Enable Control

### Filtering

To limit the input voltage drop during hot-plug events, connect a 1μF ceramic capacitor from V<sub>IN</sub> to GND. However, higher capacitor values will further reduce the voltage drop at the input.

Connect a sufficient capacitor from V<sub>OUT</sub> to GND. This capacitor helps to prevent inductive parasitics from pulling V<sub>OUT</sub> negative during turn-off or EMI damage to other components during the hot-detachment. It is also necessary for meeting the USB specification during hot plug-in operation. If CS9729 is implanted in device end application, minimum 1μF capacitor from V<sub>OUT</sub> to GND is recommended and higher capacitor values are also preferred.



In choosing these capacitors, special attention must be paid to the Effective Series Resistance, ESR, of the capacitors to minimize the IR drop across the capacitor ESR. A lower ESR on this capacitor can get a lower IR drop during the operation.

Ferrite beads in series with all power and ground lines are recommended to eliminate or significantly reduce EMI. In selecting a ferrite bead, the DC resistance of the wire used must be kept to a minimum to reduce the voltage drop.

**Reverse Current Preventing**

The output MOSFET and driver circuitry are also designed to allow the MOSFET source to be externally forced to a higher voltage than the drain ( $V_{OUT} > V_{IN} \geq 0$ ). To prevent reverse current from such condition, disable the switch or connect VIN to a fixed voltage under 1.3V.

**Layout and Thermal Dissipation**

- ▶ Place the switch as close to the USB connector as possible. Keep all traces as short as possible to reduce the effect of undesirable parasitic inductance.
- ▶ Place the ot capacitor and ferrite beads asclose to the USB connector as possible.
- ▶ If ferrite beads are used, use wires with minimum resistance and large solder pads to minimize connection resistance.
- ▶ If the package is with dual VOUT or VIN pins, short both the same function pins as Figure 1 or Figure 2 to reduce the internal turn-on resistance. If the output power will be delivered to two individual ports, it is specially necessary to short both VOUT pin at the switch output side in order to protect the switch when each port are plug-in separately.
- ▶ Under normal operating conditions, the package can dissipate the channel heat away. Wide power-bus planes connected to VIN and VOUT and a ground plane in contact with the device will help dissipate additional heat.

## Outline Dimension

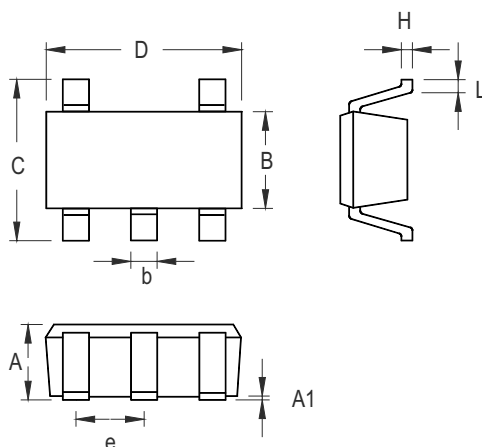

Symbol	Dimensions In Millimeters		Dimensions In Inches	
	Min	Max	Min	Max
A	0.889	1.295	0.035	0.051
A1	0.000	0.152	0.000	0.006
B	1.397	1.803	0.055	0.071
b	0.356	0.559	0.014	0.022
C	2.591	2.997	0.102	0.118
D	2.692	3.099	0.106	0.122
e	0.838	1.041	0.033	0.041
H	0.080	0.254	0.003	0.010
L	0.300	0.610	0.012	0.024

### SOT-23-5 Surface Mount Package

#### Richtek Technology Corporation

Headquarter

5F, No. 20, Taiyuen Street, Chupei City

Hsinchu, Taiwan, R.O.C.

Tel: (8863)5526789 Fax: (8863)5526611

#### Richtek Technology Corporation

Taipei Office (Marketing)

8F, No. 137, Lane 235, Paochiao Road, Hsintien City

Taipei County, Taiwan, R.O.C.

Tel: (8862)89191466 Fax: (8862)89191465

Email: [marketing@richtek.com](mailto:marketing@richtek.com)

Information that is provided by Richtek Technology Corporation is believed to be accurate and reliable. Richtek reserves the right to make any change in circuit design, specification or other related things if necessary without notice at any time. No third party intellectual property infringement of the applications should be guaranteed by users when integrating Richtek products into any application. No legal responsibility for any said applications is assumed by Richtek.