

### N-Channel Trench Power MOSFET

#### General Description

The CSD30N210 uses advanced trench technology to provide excellent  $R_{DS(ON)}$ , low gate charge and operation with gate voltages as low as 4.5V. This device is suitable for use as a wide variety of applications.

#### Features

- $V_{DS} = 30V, I_D = 23A$   
 $R_{DS(ON)} < 32m\Omega @ V_{GS} = 10V$   
 $R_{DS(ON)} < 45m\Omega @ V_{GS} = 4.5V$
- High Power and current handing capability
- Lead free product is acquired
- Surface Mount Package

#### Application

- PWM applications
- Load switch
- Power management

**100% UIS TESTED!**  
**100%  $\Delta V_{ds}$  TESTED!**

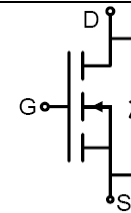

Schematic Diagram



Marking and pin Assignment

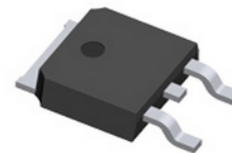

TO-252(DPAK) top view

#### Package Marking and Ordering Information

Device Marking	Device	Device Package	Reel Size	Tape width	Quantity
CSD30N210	CSD30N210	TO-252	325mm	16mm	2500

Table 1. Absolute Maximum Ratings ( $T_A=25^\circ C$ )

Symbol	Parameter	Value	Unit
$V_{DS}$	Drain-Source Voltage ( $V_{GS}=0V$ )	30	V
$V_{GS}$	Gate-Source Voltage ( $V_{DS}=0V$ )	$\pm 20$	V
$I_D$	Drain Current-Continuous( $T_C=25^\circ C$ ) (Note 1)	23	A
	Drain Current-Continuous( $T_C=100^\circ C$ )	16	A
$I_{DM (pluse)}$	Drain Current-Continuous@ Current-Pulsed (Note 2)	92	A
$P_D$	Maximum Power Dissipation( $T_C=25^\circ C$ )	37	W
	Maximum Power Dissipation( $T_C=100^\circ C$ )	18	W
$E_{AS}$	Avalanche energy (Note 3)	36	mJ
$T_J, T_{STG}$	Operating Junction and Storage Temperature Range	-55 To 175	$^\circ C$

Table 2. Thermal Characteristic

Symbol	Parameter	Typ	Max	Unit
$R_{\theta JC}$	Thermal Resistance, Junction-to-Case	-	4	$^\circ C/W$

**Table 3. Electrical Characteristics (TA=25°C unless otherwise noted)**

Symbol	Parameter	Conditions	Min	Typ	Max	Unit
<b>On/Off States</b>						
B <sub>V</sub> DSS	Drain-Source Breakdown Voltage	V <sub>GS</sub> =0V, I <sub>D</sub> =250μA	30			V
I <sub>DSS</sub>	Zero Gate Voltage Drain Current	V <sub>DS</sub> =30V, V <sub>GS</sub> =0V			1	μA
I <sub>GSS</sub>	Gate-Body Leakage Current	V <sub>GS</sub> =±20V, V <sub>DS</sub> =0V			±100	nA
V <sub>GS(th)</sub>	Gate Threshold Voltage	V <sub>DS</sub> =V <sub>GS</sub> , I <sub>D</sub> =250μA	1.0	1.5	2.5	V
g <sub>FS</sub>	Forward Transconductance	V <sub>DS</sub> =5V, I <sub>D</sub> =6A		10		S
R <sub>DS(ON)</sub>	Drain-Source On-State Resistance	V <sub>GS</sub> =10V, I <sub>D</sub> =20A		21	32	mΩ
		V <sub>GS</sub> =4.5V, I <sub>D</sub> =15A		30	45	mΩ
<b>Dynamic Characteristics</b>						
C <sub>iss</sub>	Input Capacitance	V <sub>DS</sub> =15V, V <sub>GS</sub> =0V, f=1.0MHz		540		pF
C <sub>oss</sub>	Output Capacitance			59		pF
C <sub>rss</sub>	Reverse Transfer Capacitance			51		pF
R <sub>g</sub>	Gate resistance	V <sub>GS</sub> =0V, V <sub>DS</sub> =0V, f=1.0MHz		6.7		Ω
<b>Switching Times</b>						
t <sub>d(on)</sub>	Turn-on Delay Time	V <sub>GS</sub> =10V, V <sub>DS</sub> =15V, R <sub>L</sub> =0.75Ω, R <sub>GEN</sub> =3Ω		3		nS
t <sub>r</sub>	Turn-on Rise Time			10		nS
t <sub>d(off)</sub>	Turn-Off Delay Time			12		nS
t <sub>f</sub>	Turn-Off Fall Time			3		nS
Q <sub>g</sub>	Total Gate Charge	V <sub>GS</sub> =10V, V <sub>DS</sub> =15V, I <sub>D</sub> =3.6A		12		nC
Q <sub>gs</sub>	Gate-Source Charge			2		nC
Q <sub>gd</sub>	Gate-Drain Charge			4		nC
<b>Source-Drain Diode Characteristics</b>						
I <sub>SD</sub>	Source-Drain Current(Body Diode)				23	A
V <sub>SD</sub>	Forward on Voltage	V <sub>GS</sub> =0V, I <sub>S</sub> =20A			1.2	V
t <sub>rr</sub>	Body Diode Reverse Recovery Time	I <sub>F</sub> =20A, dI/dt=100A/μs		4		ns
Q <sub>rr</sub>	Body Diode Reverse Recovery Charge	I <sub>F</sub> =20A, dI/dt=100A/μs		2		nC

Notes 1.The maximum current rating is package limited.

Notes 2.Repetitive Rating: Pulse width limited by maximum junction temperature

Notes 3.EAS condition: T<sub>J</sub>=25°C, V<sub>DD</sub>=30V, V<sub>G</sub>=10V, R<sub>G</sub>=25Ω

## Test Circuit

### 1) $E_{AS}$ Test Circuits

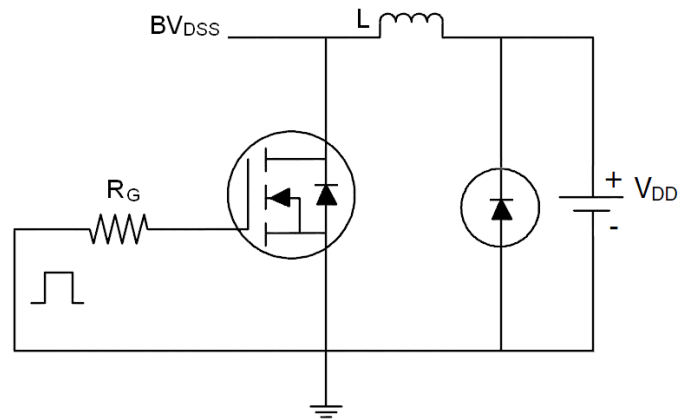
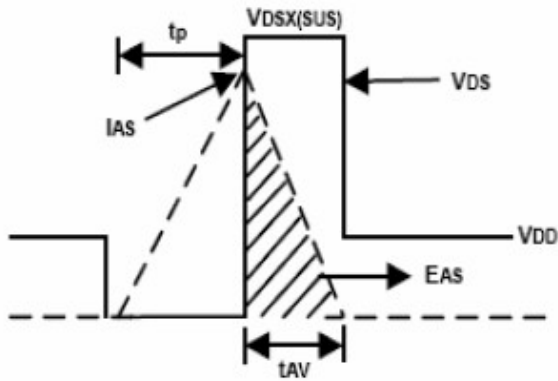

### 2) Gate Charge Test Circuit:

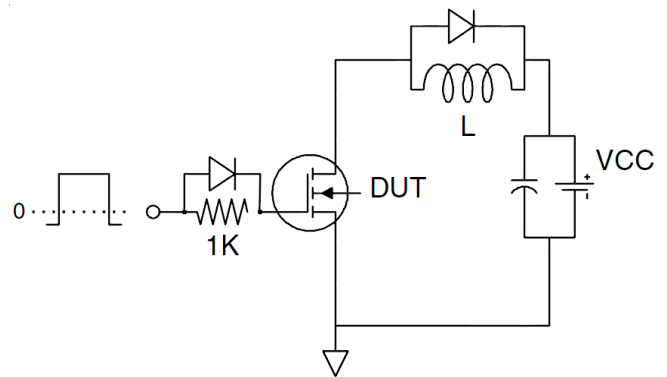
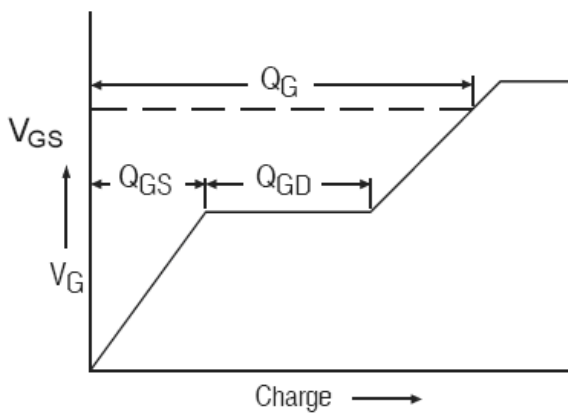

### 3) Switch Time Test Circuit:

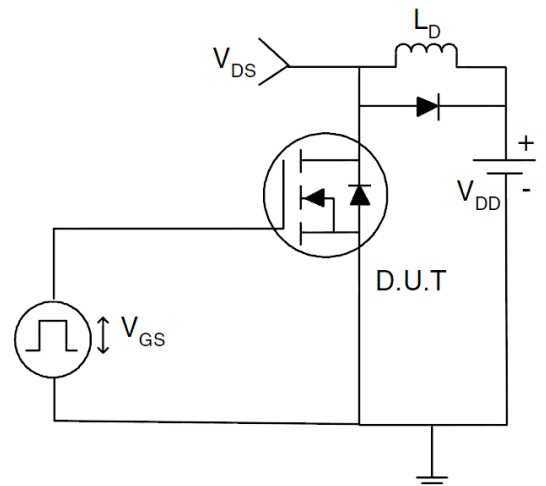
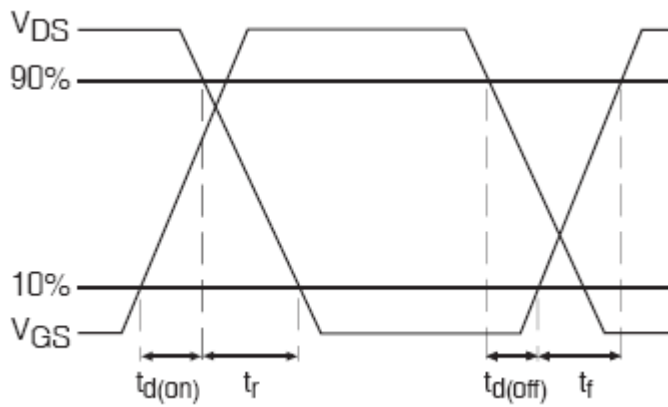

## TYPICAL ELECTRICAL AND THERMAL CHARACTERISTICS (Curves)

Figure 1. Output Characteristics

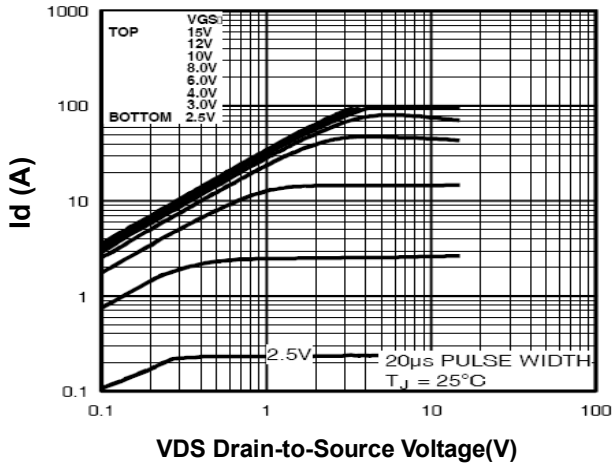

Figure 2. Transfer Characteristics

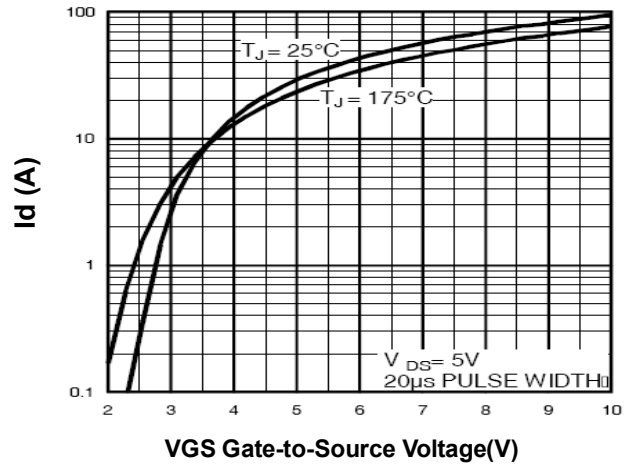

Figure 3. Max  $BV_{DSS}$  vs Junction Temperature

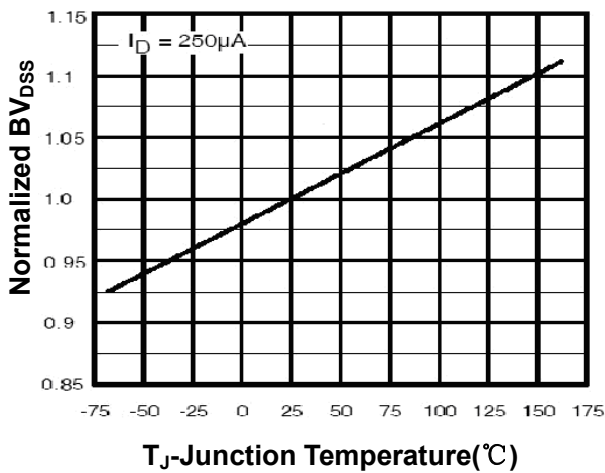

Figure 4. Drain Current

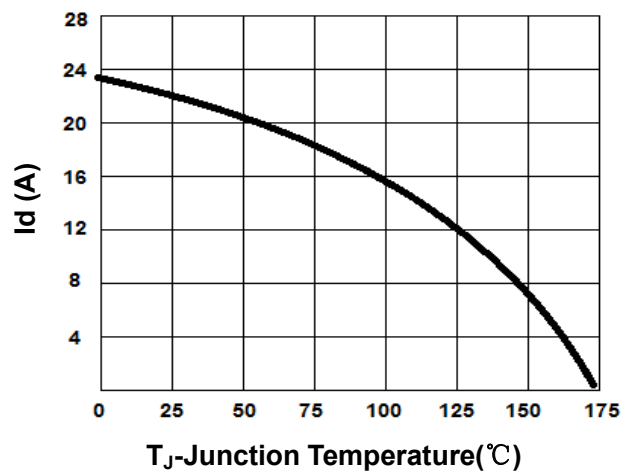

Figure 5.  $V_{GS(th)}$  vs Junction Temperature

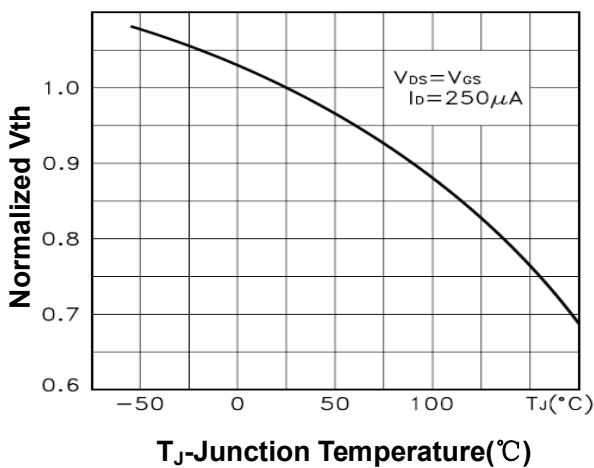

Figure 6.  $R_{DS(ON)}$  vs Junction Temperature

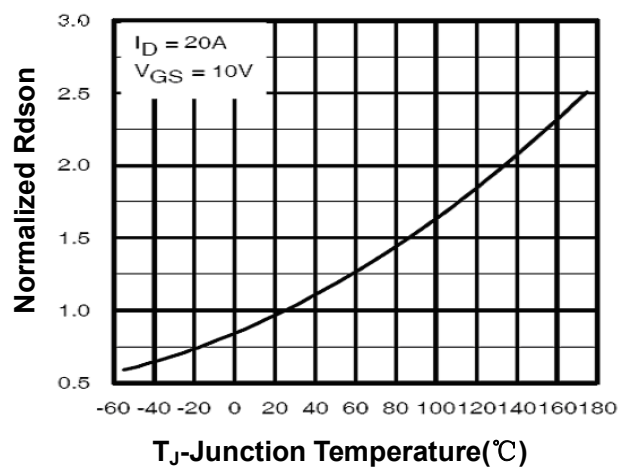

Figure 7. Gate Charge Waveforms

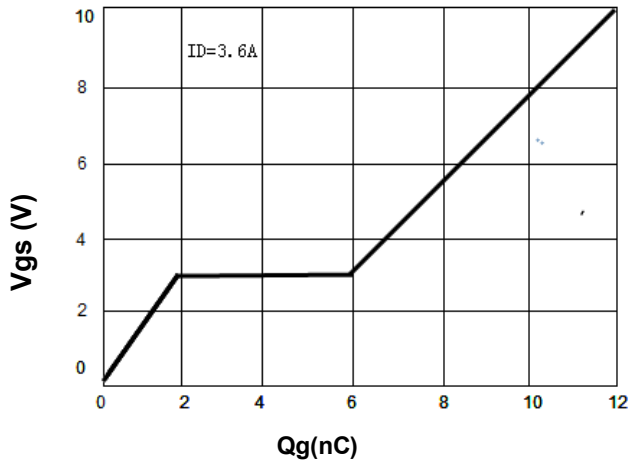

Figure 8. Capacitance

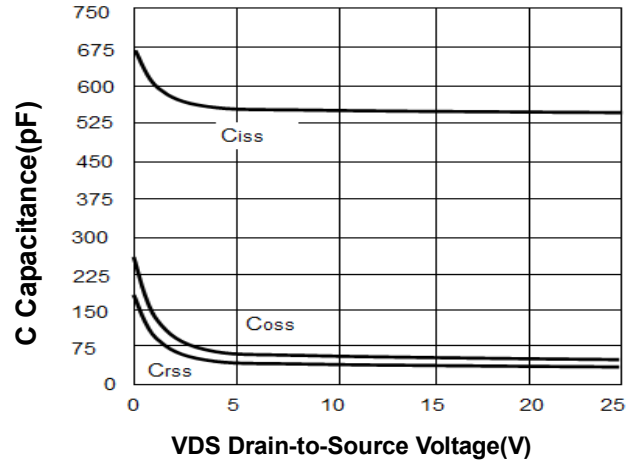

Figure 9. Body-Diode Characteristics

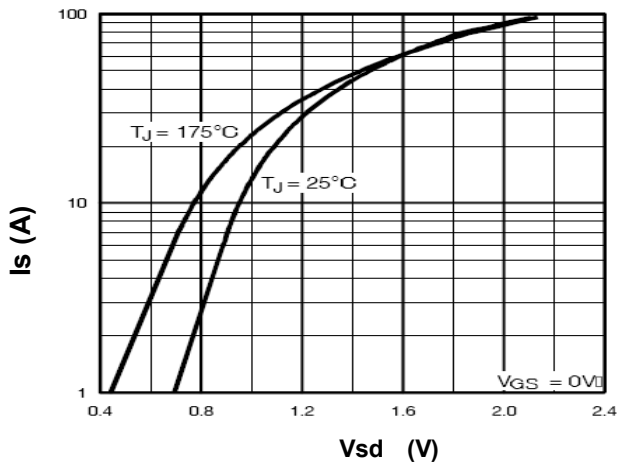

Figure 10. Maximum Safe Operating Area

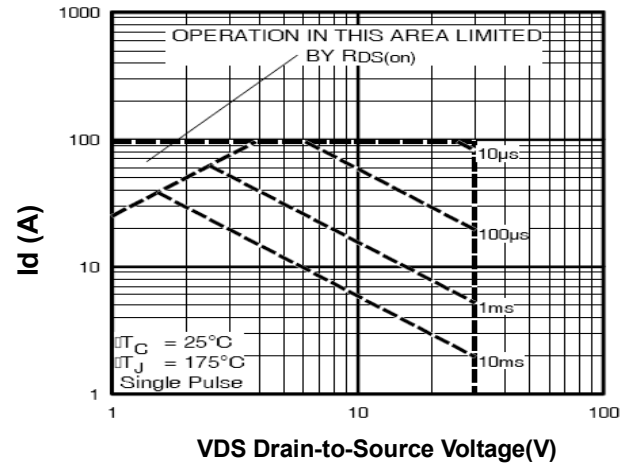
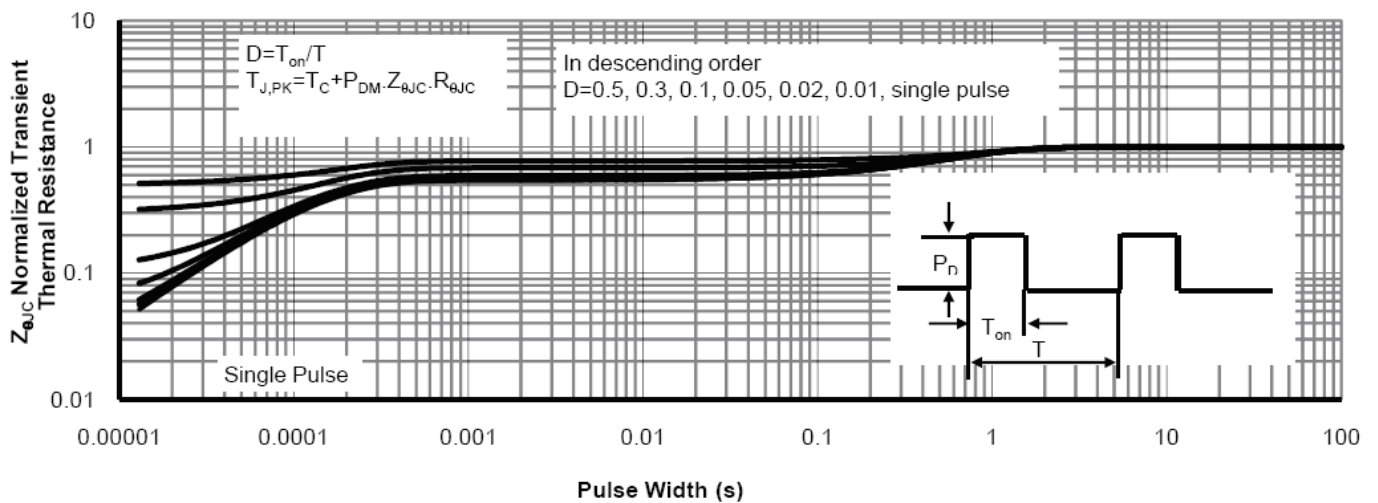
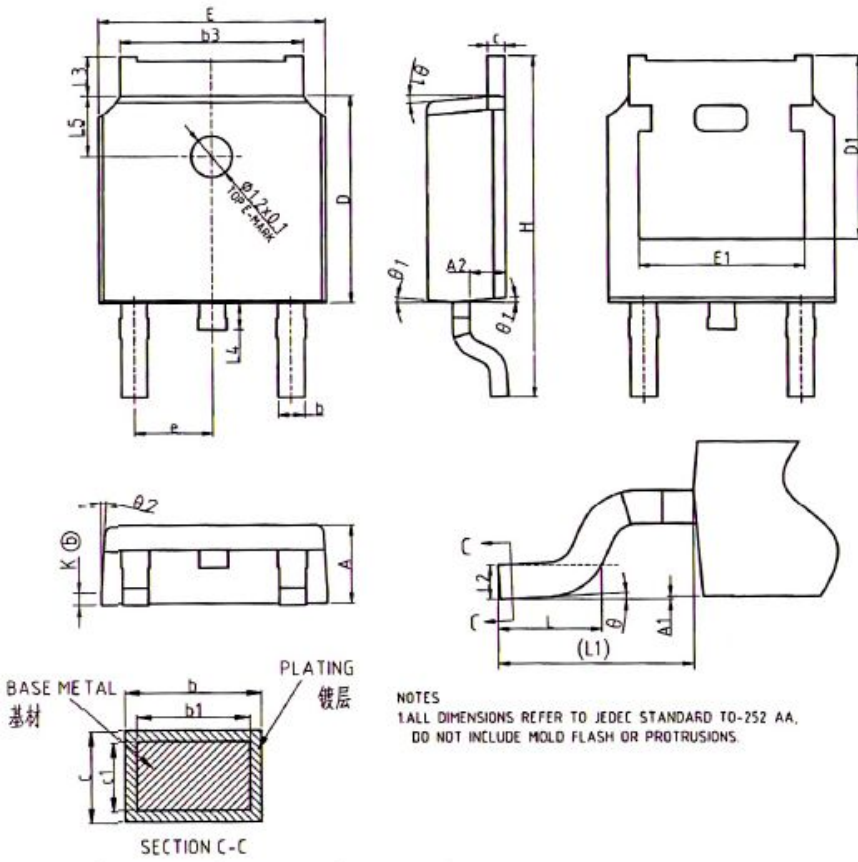

Figure 11. Normalized Maximum Transient Thermal Impedance



## TO-252 Package Information



NOTES  
 1. ALL DIMENSIONS REFER TO JEDEC STANDARD TO-252 AA.  
 DO NOT INCLUDE MOLD FLASH OR PROTRUSIONS.

COMMON DIMENSIONS			
SYMBOL	mm		
	MIN	NOM	MAX
A	2.20	2.30	2.38
A1	0.00	-	0.10
A2	0.97	1.07	1.17
b	0.72	0.78	0.85
b1	0.71	0.76	0.81
b3	5.23	5.33	5.46
c	0.47	0.53	0.58
c1	0.46	0.51	0.56
D	6.00	6.10	6.20
D1	5.30REF		
E	6.50	6.60	6.70
E1	4.70	4.83	4.92
e	2.286BSC		
H	9.90	10.10	10.30
L	1.40	1.50	1.70
L1	2.90REF		
L2	0.51BSC		
L3	0.90	-	1.25
L4	0.60	0.80	1.00
L5	1.70	1.80	1.90
$\theta$	0°	-	8°
$\theta_1$	5°	7°	9°
$\theta_2$	5°	7°	9°
K	0.40REF		