

## N-Channel Trench Power MOSFET

### General Description

The CSD60N53 combines advanced trench MOSFET technology with a low resistance package to provide extremely low  $R_{DS(ON)}$ . Those devices are suitable for use in PWM, load switching and general purpose applications.

### Features

- $V_{DS}=60V$ ;  $I_D=88A$   
 $R_{DS(ON)}<6.6m\Omega @ V_{GS}=10V$
- Ultra Low On-Resistance
- High UIS and UIS 100% Test

### Application

- Power switching application
- load switching

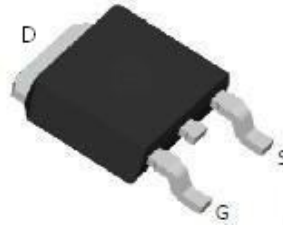

To-252 Top View

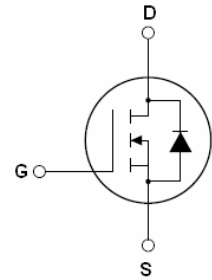

Schematic Diagram

$$V_{DS} = 60V$$

$$I_D = 88A$$

$$R_{DS(ON)} = 5.5m\Omega$$

### Package Marking and Ordering Information

Device Marking	Device	Device Package	Reel Size	Tape width	Quantity
CSD60N53	CSD60N53	TO-252	-	-	-

Table 1. Absolute Maximum Ratings (TA=25°C)

Symbol	Parameter	Value	Unit
$V_{DS}$	Drain-Source Voltage ( $V_{GS}=0V$ )	60	V
$V_{GS}$	Gate-Source Voltage ( $V_{DS}=0V$ )	$\pm 20$	V
$I_{D(DC)}$	Drain Current (DC) at $T_c=25^\circ C$	88	A
$I_{D(DC)}$	Drain Current (DC) at $T_c=100^\circ C$	62	A
$I_{DM(pulse)}$	Drain Current-Continuous@ Current-Pulsed (Note 1)	352	A
$P_D$	Maximum Power Dissipation( $T_c=25^\circ C$ )	111	W
$E_{AS}$	Single Pulse Avalanche Energy (Note 2)	484	mJ
$T_J, T_{STG}$	Operating Junction and Storage Temperature Range	-55 To 175	$^\circ C$

Notes 1. Repetitive Rating: Pulse width limited by maximum junction temperature

2. EAS condition:  $T_J=25^\circ C, V_{DD}=30V, V_G=10V, R_G=25\Omega$

**Table 2. Thermal Characteristic**

Symbol	Parameter	Value	Max	Unit
R <sub>θJC</sub>	Thermal Resistance, Junction-to-Case	---	1.35	°C/W

**Table 3. Electrical Characteristics (TA=25°C unless otherwise noted)**

Symbol	Parameter	Conditions	Min	Typ	Max	Unit
<b>On/Off States</b>						
BV <sub>DSS</sub>	Drain-Source Breakdown Voltage	V <sub>GS</sub> =0V, I <sub>D</sub> =250μA	60			V
I <sub>DSS</sub>	Zero Gate Voltage Drain Current(Tc=25°C)	V <sub>DS</sub> =60V, V <sub>GS</sub> =0V			1	μA
I <sub>DSS</sub>	Zero Gate Voltage Drain Current(Tc=100°C)	V <sub>DS</sub> =60V, V <sub>GS</sub> =0V			5	μA
I <sub>GSS</sub>	Gate-Body Leakage Current	V <sub>GS</sub> =±20V, V <sub>DS</sub> =0V			±100	nA
V <sub>GS(th)</sub>	Gate Threshold Voltage	V <sub>DS</sub> =V <sub>GS</sub> , I <sub>D</sub> =250μA	2		4	V
R <sub>DS(ON)</sub>	Drain-Source On-State Resistance	V <sub>GS</sub> =10V, I <sub>D</sub> =12A		5.5	6.6	mΩ
<b>Dynamic Characteristics</b>						
g <sub>FS</sub>	Forward Transconductance	V <sub>DS</sub> =10V, I <sub>D</sub> =15A	20			S
C <sub>iss</sub>	Input Capacitance	V <sub>DS</sub> =30V, V <sub>GS</sub> =0V f=1.0MHz		4060		PF
C <sub>oss</sub>	Output Capacitance			385		PF
C <sub>rss</sub>	Reverse Transfer Capacitance			292		PF
Q <sub>g</sub>	Total Gate Charge	V <sub>DS</sub> =30V, I <sub>D</sub> =15A V <sub>GS</sub> =10V		102		nC
Q <sub>gs</sub>	Gate-Source Charge			20		nC
Q <sub>gd</sub>	Gate-Drain Charge			49		nC
<b>Switching Times</b>						
t <sub>d(on)</sub>	Turn-on Delay Time	V <sub>DS</sub> =30V, R <sub>L</sub> =2.5Ω V <sub>GS</sub> =10V, R <sub>G</sub> =3Ω		24		nS
t <sub>r</sub>	Turn-on Rise Time			32		nS
t <sub>d(off)</sub>	Turn-Off Delay Time			69		nS
t <sub>f</sub>	Turn-Off Fall Time			31		nS
<b>Source-Drain Diode Characteristics</b>						
I <sub>SD</sub>	Source-Drain Current(Body Diode)			88		A
I <sub>SDM</sub>	Pulsed Source-Drain Current(Body Diode)			352		A
V <sub>SD</sub>	Forward On Voltage <sup>(Note 1)</sup>	T <sub>J</sub> =25°C, I <sub>SD</sub> =1A, V <sub>GS</sub> =0V		0.87	0.99	V
t <sub>rr</sub>	Reverse Recovery Time <sup>(Note 1)</sup>	T <sub>J</sub> =25°C, I <sub>F</sub> =15A di/dt=100A/μs		28		nS
Q <sub>rr</sub>	Reverse Recovery Charge <sup>(Note 1)</sup>				39	
t <sub>on</sub>	Forward Turn-on Time	Intrinsic turn-on time is negligible(turn-on is dominated by L <sub>S</sub> +L <sub>D</sub> )				

Notes 1. Pulse Test: Pulse Width ≤ 300μs, Duty Cycle ≤ 1.5%, Starting T<sub>J</sub>=25°C

## Test Circuit

### 1) E<sub>AS</sub> Test Circuits

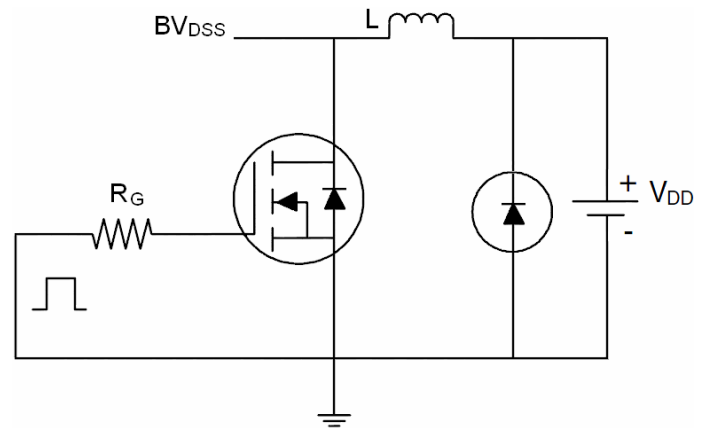
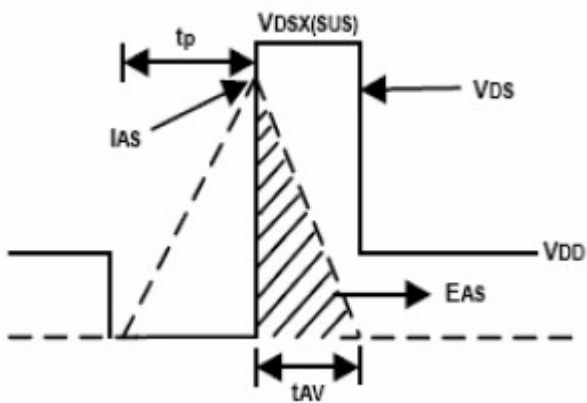

### 2) Gate Charge Test Circuit:

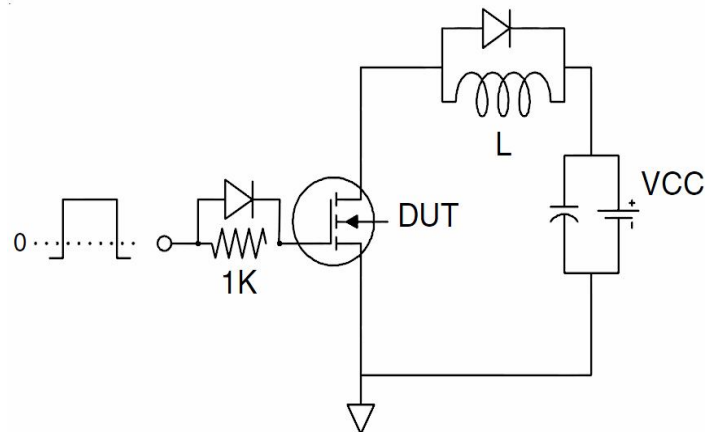
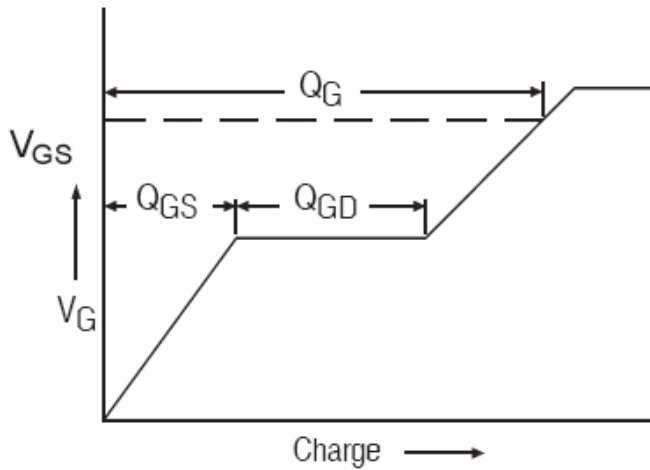

### 3) Switch Time Test Circuit:

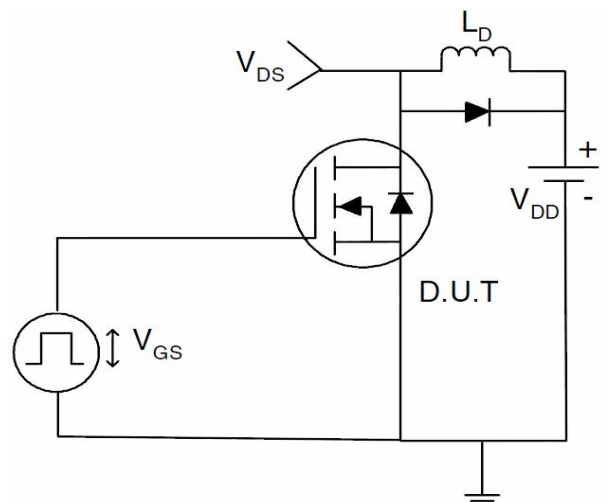
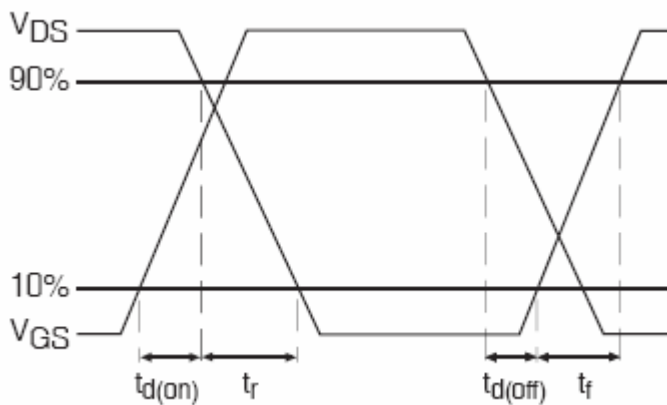

## TYPICAL ELECTRICAL AND THERMAL CHARACTERISTICS (Curves)

**Figure1. Output Characteristics**

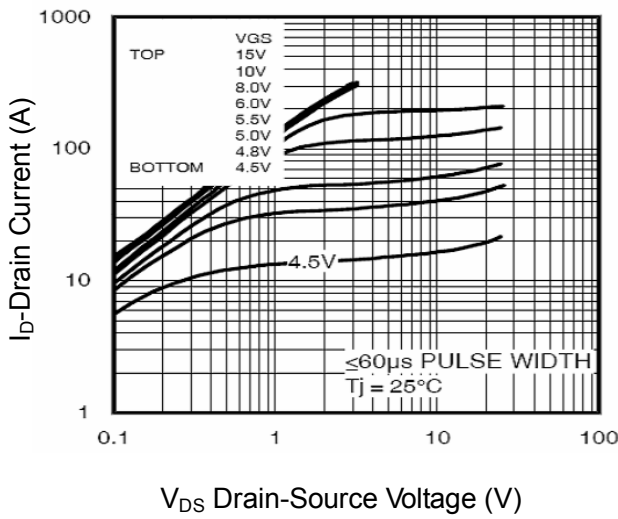

**Figure2. Transfer Characteristics**

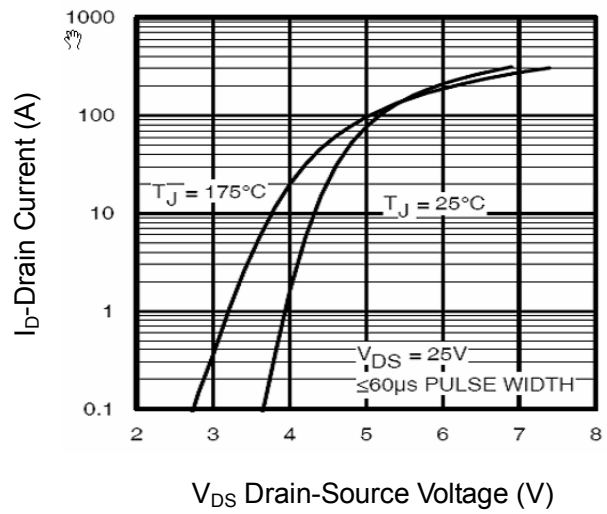

**Figure3. BV<sub>DSS</sub> vs Junction Temperature**

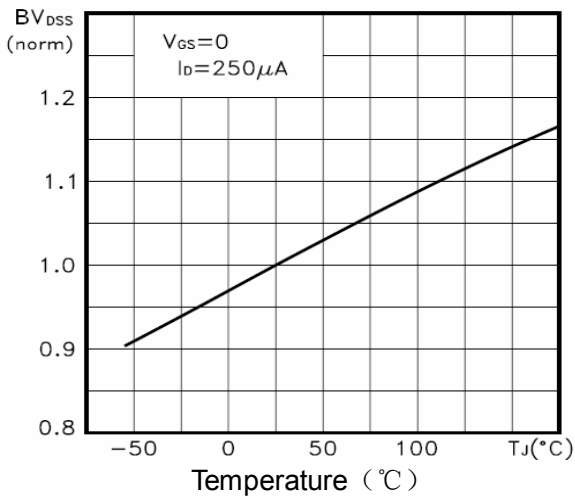

**Figure4. ID vs Junction Temperature**

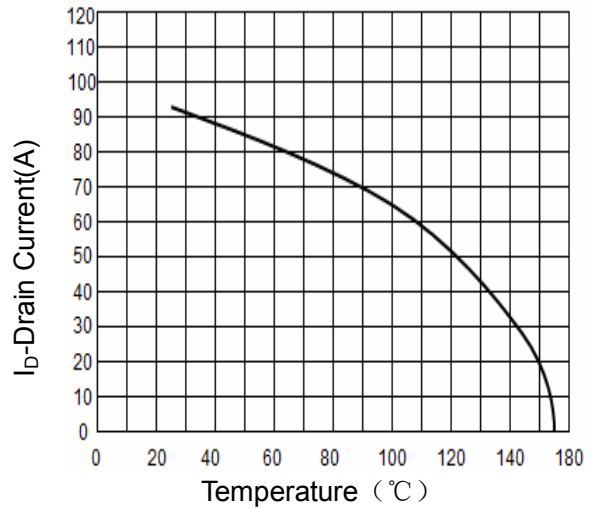

**Figure5. VGS(th) vs Junction Temperature**

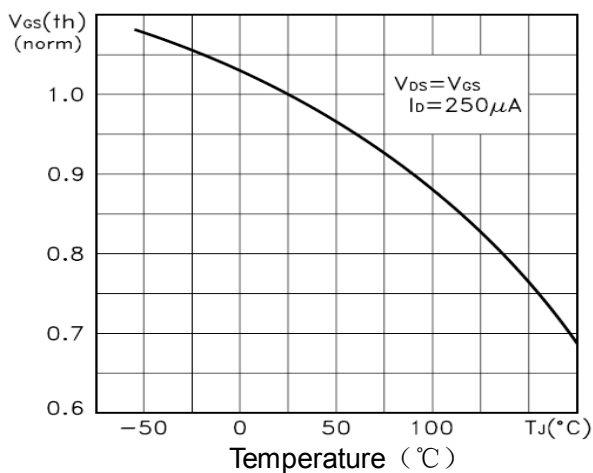

**Figure6. R<sub>dson</sub> Vs Junction Temperature**

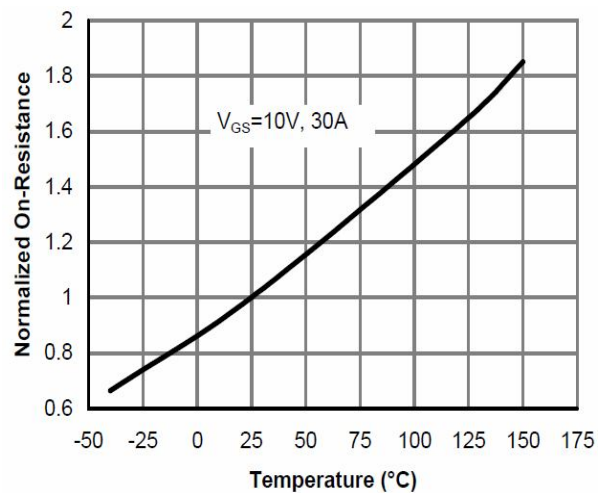

**Figure7. Gate Charge**

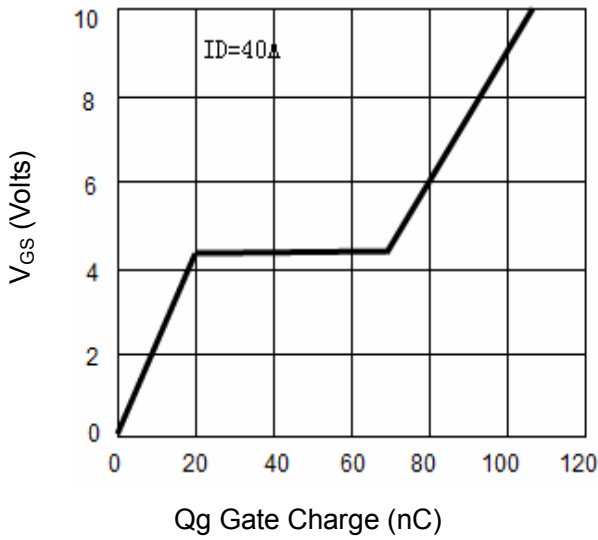

**Figure8. Capacitance vs Vds**

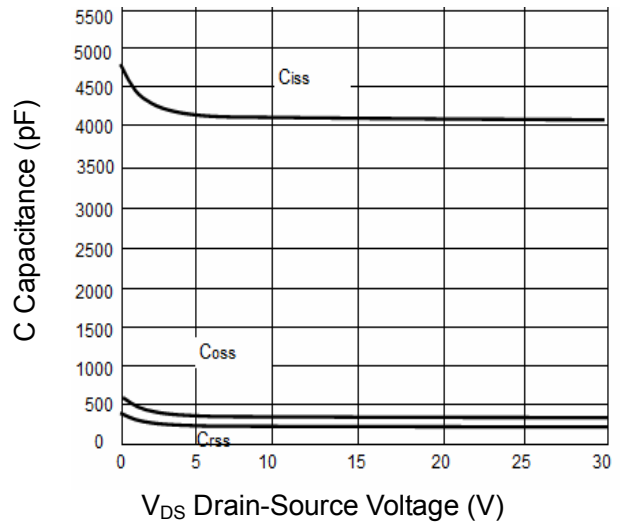

**Figure9. Source- Drain Diode Forward**

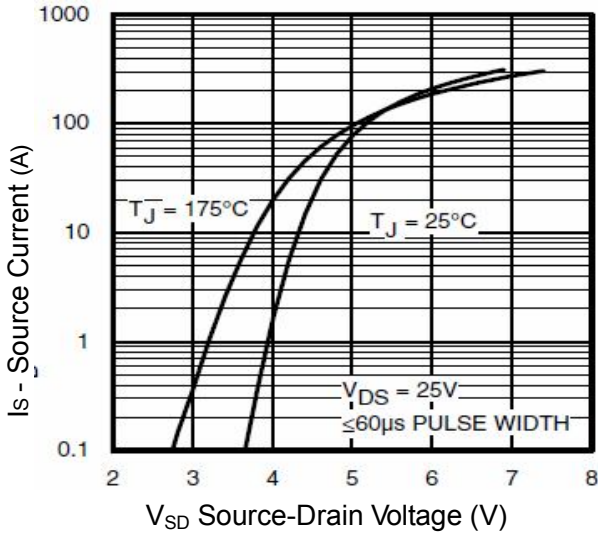

**Figure10. Safe Operation Area**

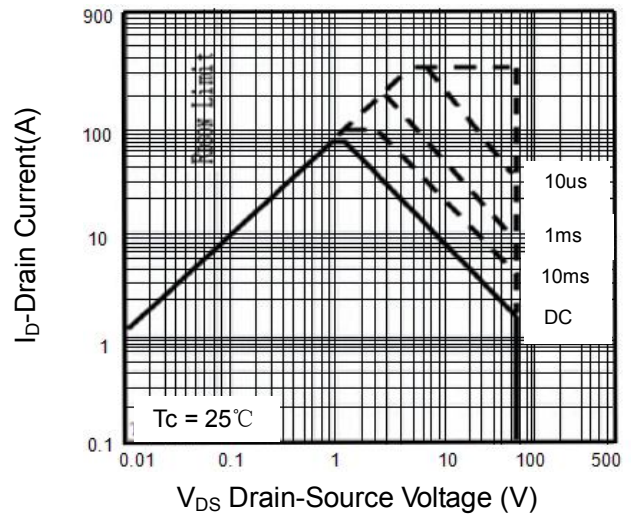

**Figure11. Normalized Maximum Transient Thermal Impedance**

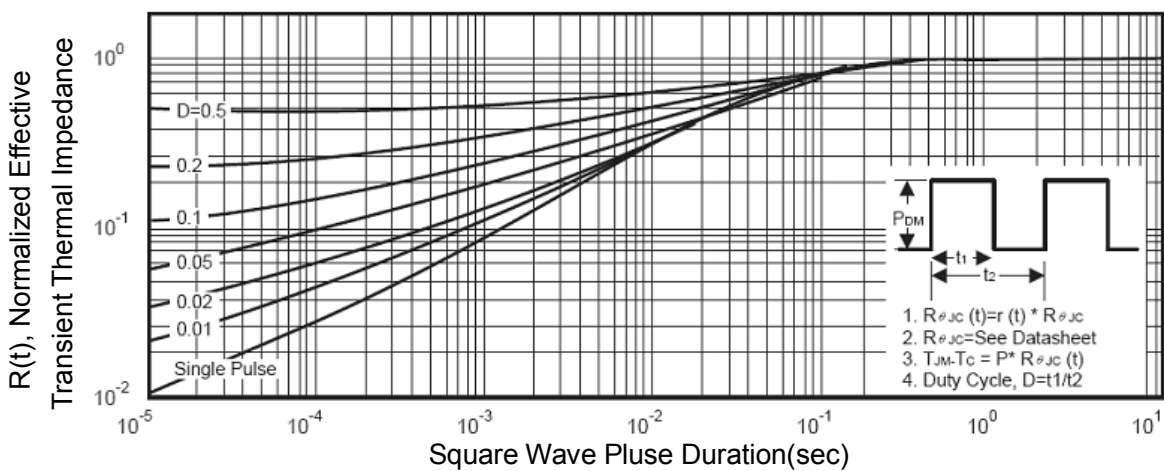

## TO-252 Package Information

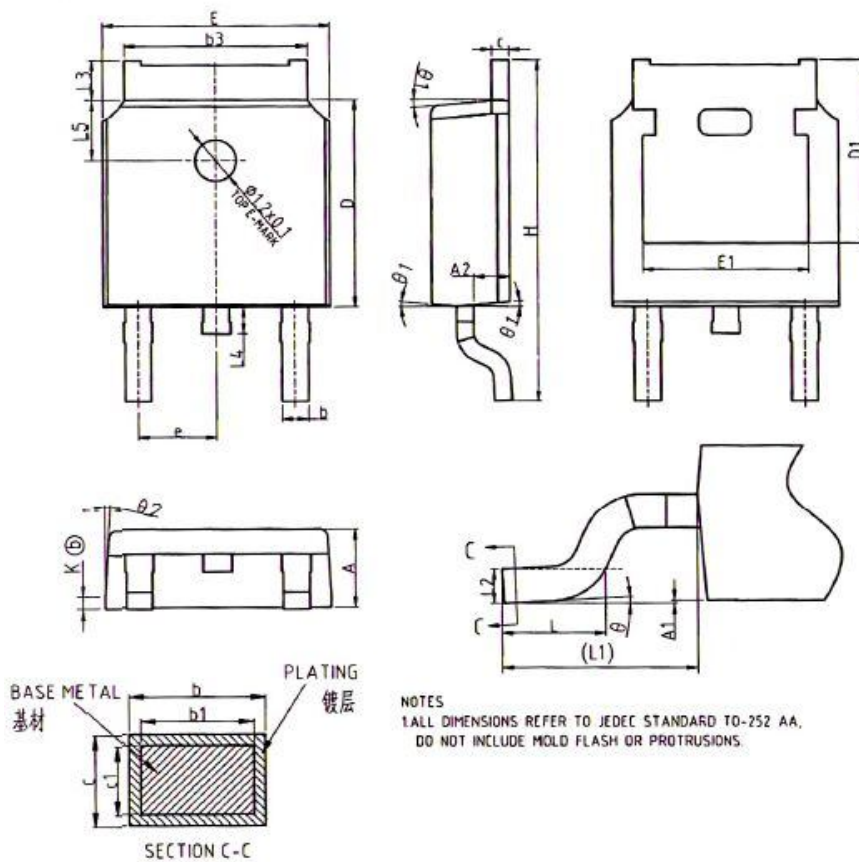

COMMON DIMENSIONS			
SYMBOL	mm		
	MIN	NOM	MAX
A	2.20	2.30	2.38
A1	0.00	-	0.10
A2	0.97	1.07	1.17
b	0.72	0.78	0.85
b1	0.71	0.76	0.81
b3	5.23	5.33	5.46
c	0.47	0.53	0.58
c1	0.46	0.51	0.56
D	6.00	6.10	6.20
D1	5.30REF		
E	6.50	6.60	6.70
E1	4.70	4.83	4.92
e	2.286BSC		
H	9.90	10.10	10.30
L	1.40	1.50	1.70
L1	2.90REF		
L2	0.51BSC		
L3	0.90	-	1.25
L4	0.60	0.80	1.00
L5	1.70	1.80	1.90
$\theta$	0°	-	8°
$\theta 1$	5°	7°	9°
$\theta 2$	5°	7°	9°
K	0.40REF		

NOTES  
 1 ALL DIMENSIONS REFER TO JEDEC STANDARD TO-252 AA.  
 DO NOT INCLUDE MOLD FLASH OR PROTRUSIONS.