

**10Amp. Schottky Barrier Rectifiers**

# CSK1040J3

**Features**

- Excellent power dissipation offers better reverse leakage current and thermal resistance
- Low profile surface mount application in order to optimize board space
- Metal silicon junction, major carrier conduction
- 10A total (5A per diode leg)
- Guardring for over voltage protection
- Low power loss, high efficiency
- High surge capability
- High current capability, low forward voltage drop
- Ultra-high speed switching
- Lead-free parts meet environmental standard MIL-STD-19500 /228

**Mechanical Data**

- Case: Molded plastic, TO-252
- Mounting Position: Any
- Weight: 0.34 grams approximately
- Terminals: Pure tin plated, lead-free, solderable per MIL-STD-750 method 2026
- Epoxy: UL 94V-0 rate flame retardant
- Polarity : Indicated by diode symbol

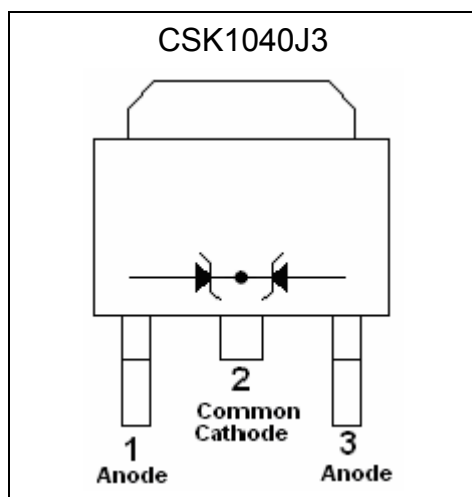
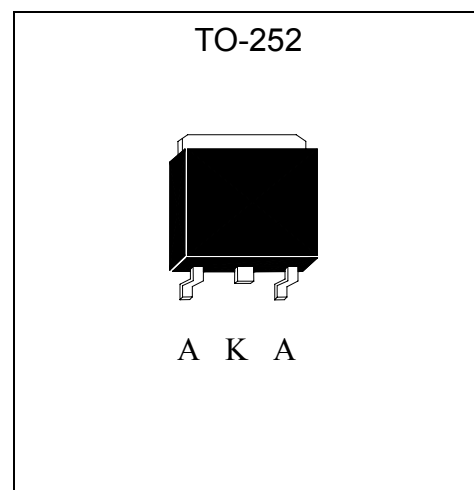
**Equivalent Circuit****Outline**

## Maximum Ratings and Electrical Characteristics (Per Diode Leg)

(Rating at 25°C ambient temperature unless otherwise specified. Single phase, half wave, 60Hz, resistive or inductive load. For capacitive load, derate current by 20%.)

Parameter	Symbol	Limits	Units
Maximum Recurrent peak reverse voltage	V <sub>RRM</sub>	40	V
Maximum RMS voltage	V <sub>RMS</sub>	28	V
Maximum DC blocking voltage	V <sub>DC</sub>	40	V
Maximum instantaneous forward voltage at I <sub>F</sub> =5A	V <sub>F</sub>	0.55	V
Maximum Average forward rectified current	Per Diode	5	A
	Per Device	10	
Non-repetitive peak forward surge current @8.3ms single half sine wave superimposed on rated load (JEDEC method)	I <sub>FSM</sub>	100	A
Maximum instantaneous reverse current at V <sub>R</sub> =40V, T <sub>A</sub> = 25°C V <sub>R</sub> =40V, T <sub>A</sub> = 100°C	I <sub>R</sub>	0.5	mA
		20	
Maximum Thermal Resistance, Junction-to-case	R <sub>θJC</sub>	3	°C/W
Maximum Thermal Resistance, Junction-to-ambient	R <sub>θJA</sub>	125	°C/W
Storage temperature range	T <sub>stg</sub>	-65 ~ +175	°C
Operating junction temperature range	T <sub>J</sub>	-55 ~ +125	°C

## Ordering Information

Device	Package	Shipping	Marking
CSK1040J3	TO-252 (Pb-free)	3000 pcs / Tape & Reel	SK1040

## Recommended soldering footprint

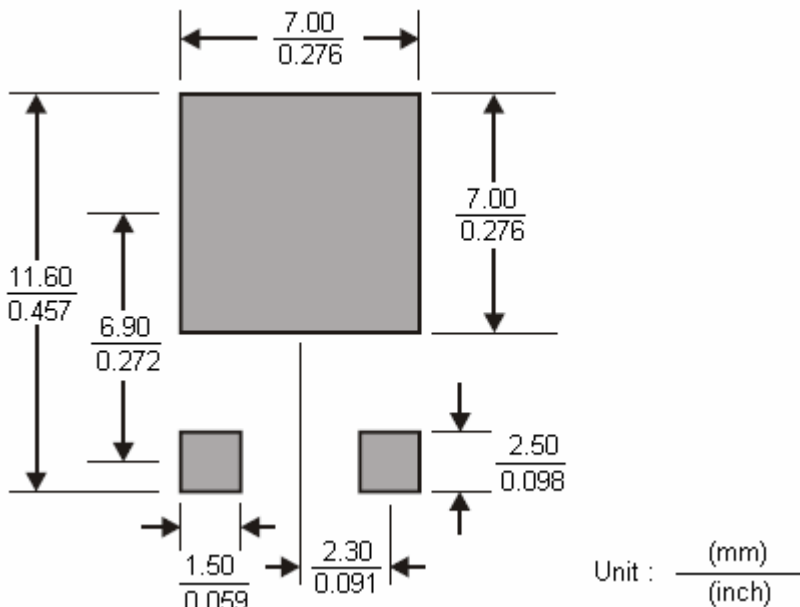

**Characteristic Curves**

Forward Current Derating Curve

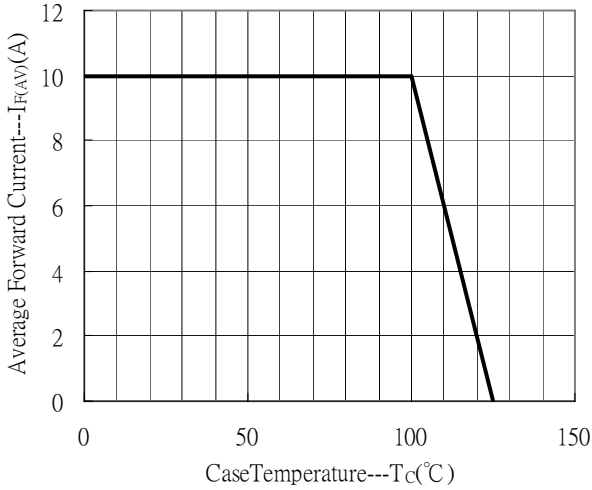

Maximum Non-Repetitive Forward Surge Current

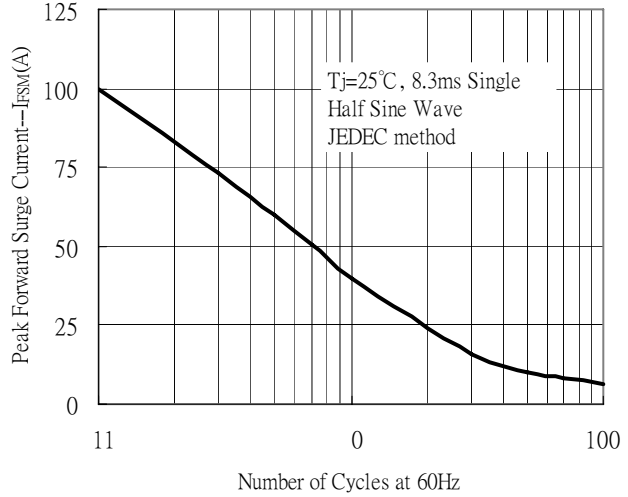

Forward Current vs Forward Voltage

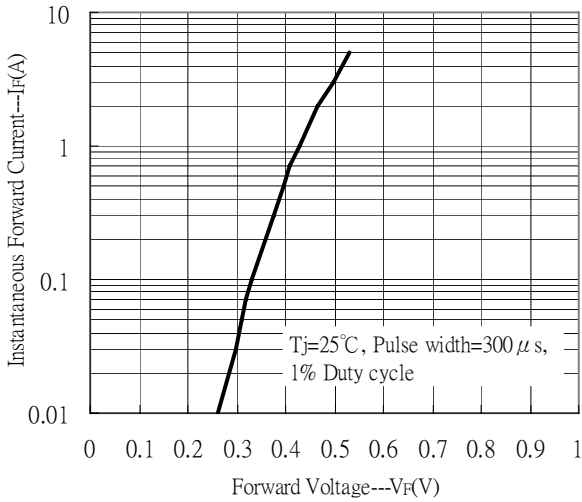

Reverse Leakage Current vs Reverse Voltage

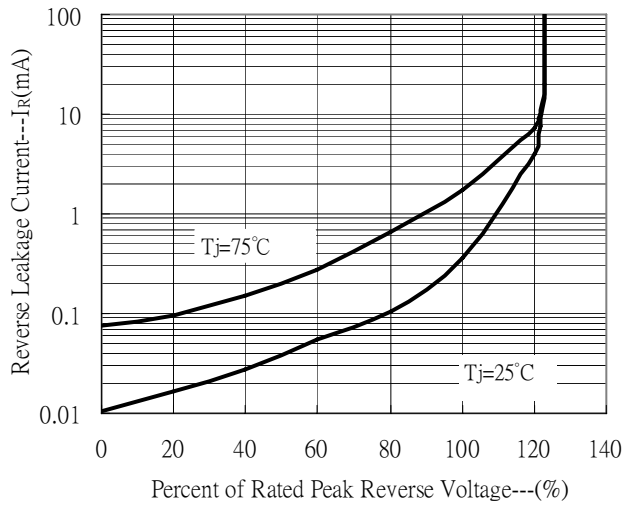

## Reel Dimension

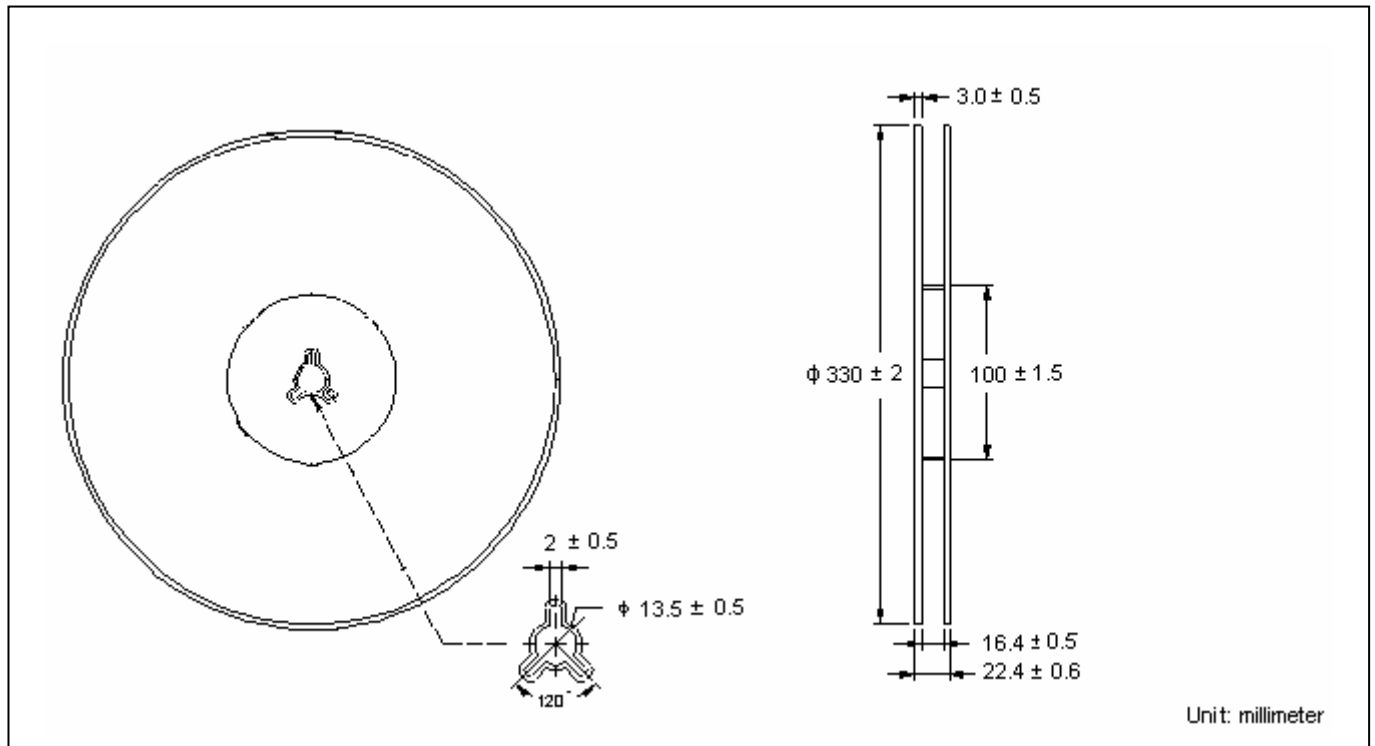

## Carrier Tape Dimension

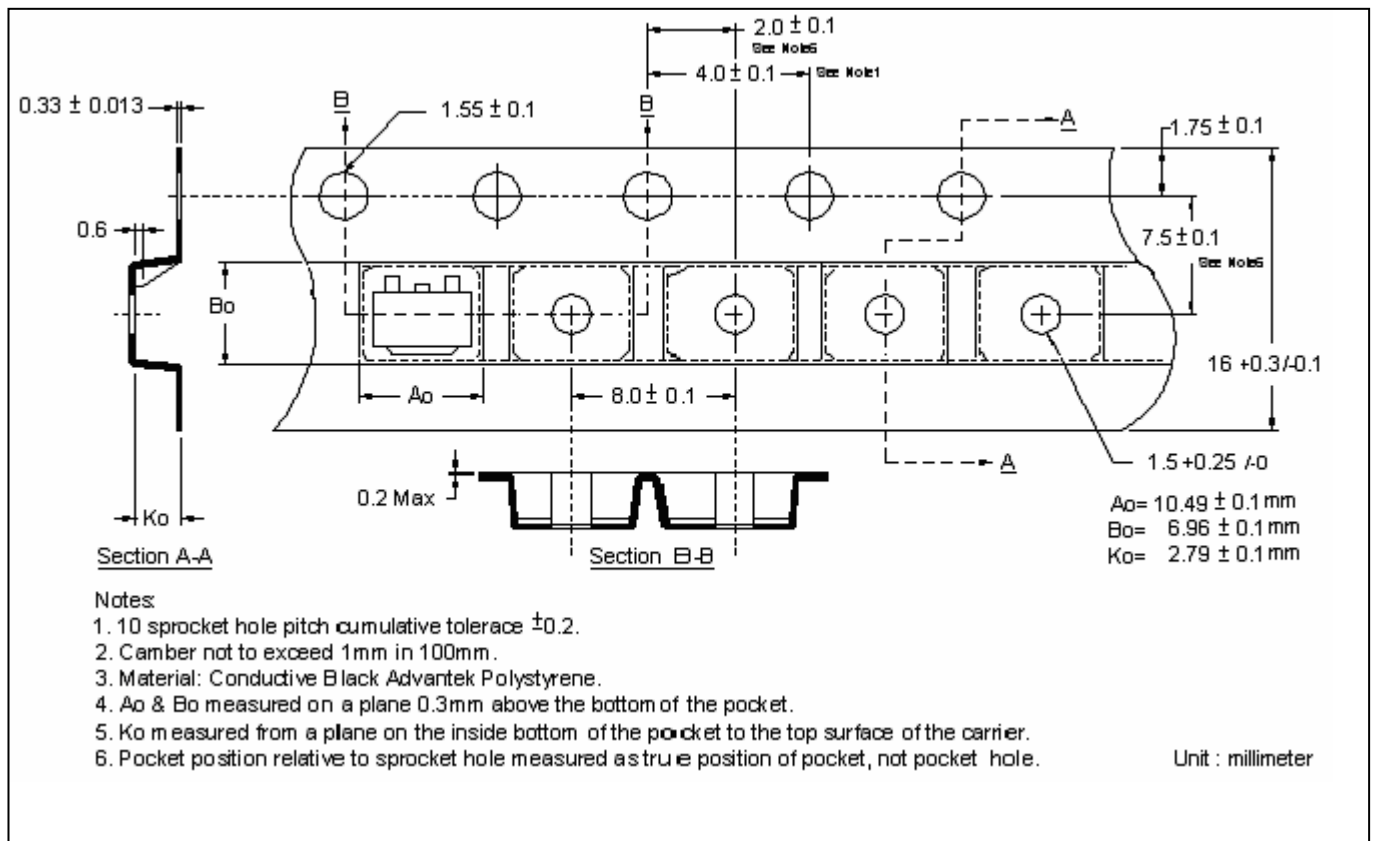

**Recommended wave soldering condition**

Product	Peak Temperature	Soldering Time
Pb-free devices	260 +0/-5 °C	5 +1/-1 seconds

**Recommended temperature profile for IR reflow**

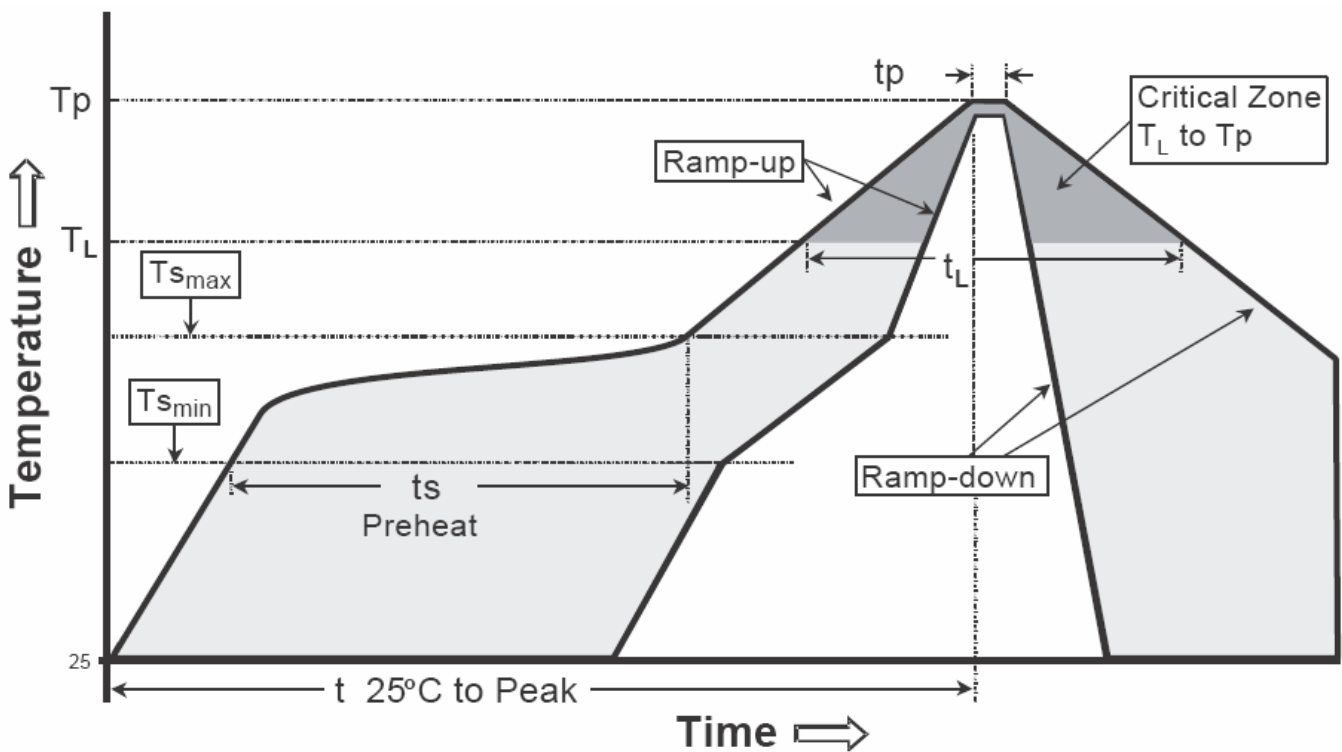

Profile feature	Sn-Pb eutectic Assembly	Pb-free Assembly
Average ramp-up rate (Tsmmax to Tp)	3°C/second max.	3°C/second max.
Preheat		
-Temperature Min(Ts min)	100°C	150°C
-Temperature Max(Ts max)	150°C	200°C
-Time(ts min to ts max)	60-120 seconds	60-180 seconds
Time maintained above:		
-Temperature (Tl)	183°C	217°C
- Time (tL)	60-150 seconds	60-150 seconds
Peak Temperature(Tp)	240 +0/-5 °C	260 +0/-5 °C
Time within 5°C of actual peak temperature(tp)	10-30 seconds	20-40 seconds
Ramp down rate	6°C/second max.	6°C/second max.
Time 25 °C to peak temperature	6 minutes max.	8 minutes max.

**TO-252 Dimension**

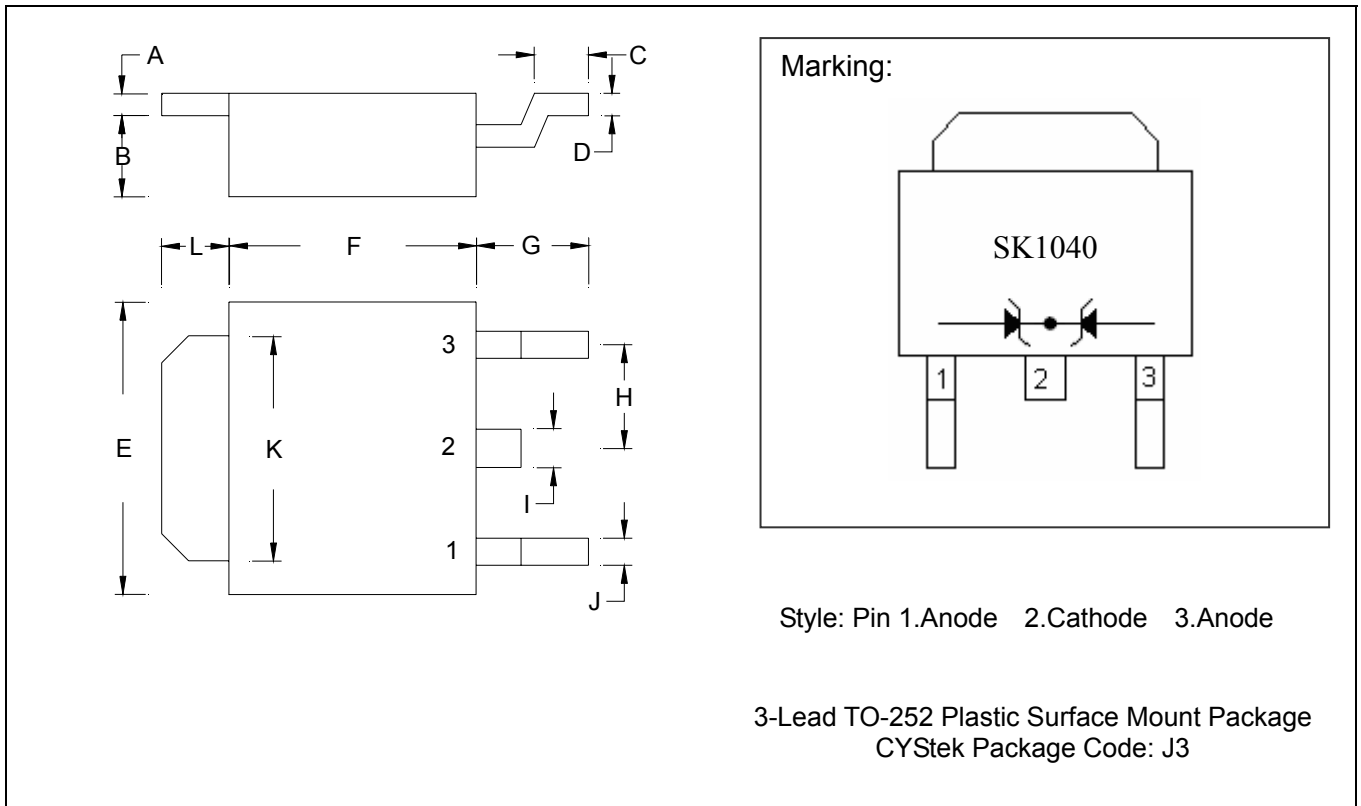

\*: Typical

DIM	Inches		Millimeters		DIM	Inches		Millimeters	
	Min.	Max.	Min.	Max.		Min.	Max.	Min.	Max.
A	0.0157	0.0236	0.40	0.60	G	0.0984	0.1142	2.50	2.90
B	0.0591	0.0827	1.50	2.10	H	-	*0.0906	-	*2.30
C	0.0157	0.0315	0.40	0.80	I	0.0315	0.0394	0.80	1.00
D	0.0157	0.0236	0.40	0.60	J	0.0315	0.0394	0.80	1.00
E	0.2480	0.2638	6.30	6.70	K	0.2008	0.2165	5.10	5.50
F	0.2283	0.2441	5.80	6.20	L	0.0315	0.0394	0.80	1.00

- Notes: 1.Controlling dimension: millimeters.  
 2.Maximum lead thickness includes lead finish thickness, and minimum lead thickness is the minimum thickness of base material.  
 3.If there is any question with packing specification or packing method, please contact your local CYStek sales office.

**Material:**

- Lead: KFC; pure tin plated
- Mold Compound: Epoxy resin family, flammability solid burning class: UL94V-0

**Important Notice:**

- All rights are reserved. Reproduction in whole or in part is prohibited without the prior written approval of CYStek.
- CYStek reserves the right to make changes to its products without notice.
- CYStek **semiconductor products are not warranted to be suitable for use in Life-Support Applications, or systems.**
- CYStek assumes no liability for any consequence of customer product design, infringement of patents, or application assistance.