

SMD Magnetic Transducer (AC)

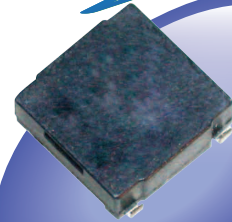

CSMT0802-S

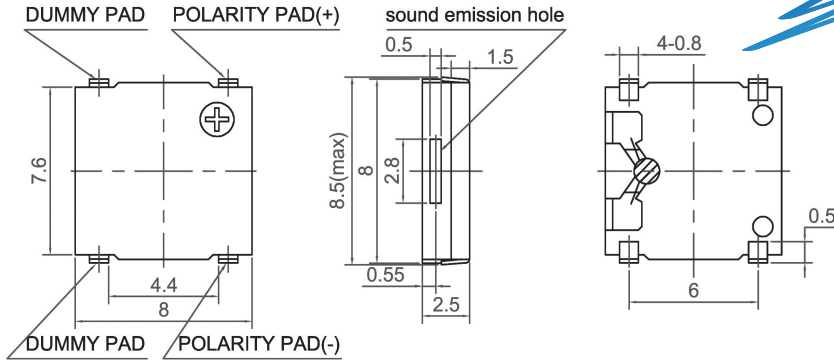
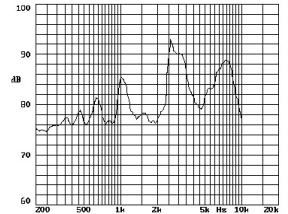

Canopus Part no.	Operating Voltage (V)	Rated Voltage (V)	Max Rated Current (mA)	Coil Resistance (Ω)	Min Sound Output (dBA)	Resonant Frequency (Hz)	Operating Temperature ($^{\circ}$ C)	Housing	Weight (g)
CSMT0802D2670LS	2 ~ 5	3.6	90	16 \pm 2.4	88 at 10cm	2670	-20 ~ +70	LCP	0.37
CSMT0802D2731LS	2 ~ 5	3.6	90	16 \pm 2.4	88 at 10cm	2731	-20 ~ +70	LCP	0.37

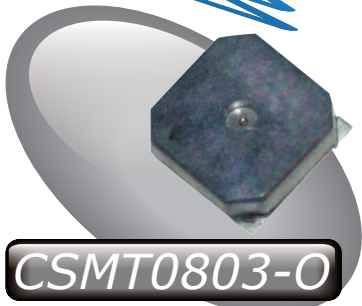

CSMT0803-O

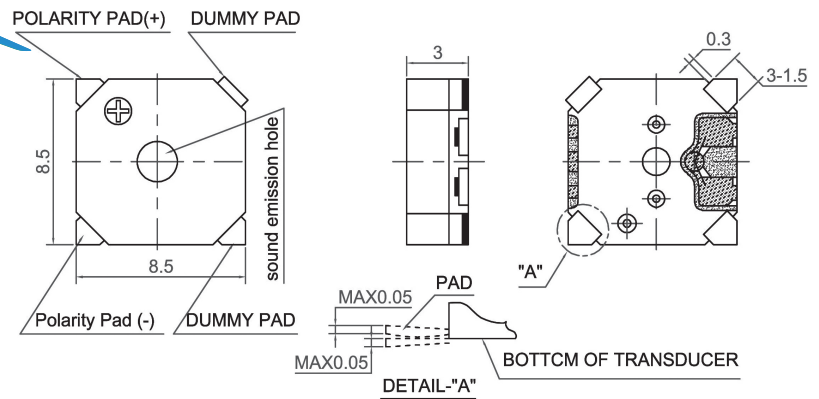
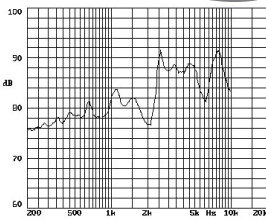

Canopus Part no.	Operating Voltage (V)	Rated Voltage (V)	Max Rated Current (mA)	Coil Resistance (Ω)	Min Sound Output (dBA)	Resonant Frequency (Hz)	Operating Temperature ($^{\circ}$ C)	Housing	Weight (g)
CSMT0803D2500L	2 ~ 5	3.6	90	16 \pm 2.4	88 at 10cm	2500	-20 ~ +70	LCP	0.4

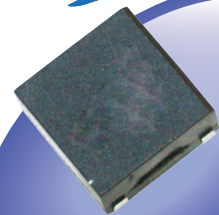
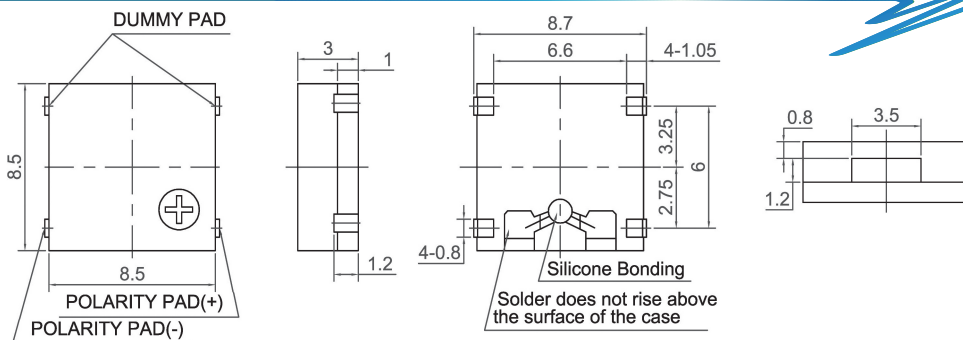

CSMT0803-S

Canopus Part no.	Operating Voltage (V)	Rated Voltage (V)	Max Rated Current (mA)	Coil Resistance (Ω)	Min Sound Output (dBA)	Resonant Frequency (Hz)	Operating Temperature ($^{\circ}$ C)	Housing	Weight (g)
CSMT0803A2350LS	1.2 ~ 1.7	1.5	80	5.5 \pm 2	80 at 10cm	2350	-20 ~ +60	LCP	0.6
CSMT0803A2730LS	1.2 ~ 1.7	1.5	80	5.5 \pm 2	80 at 10cm	2730	-30 ~ +70	LCP	0.6
CSMT0803C2350LS	3 ~ 4.5	3	80	17 \pm 3	85 at 10cm	2350	-30 ~ +70	LCP	0.6
CSMT0803C2730LS	3 ~ 4.5	3	80	17 \pm 3	85 at 10cm	2730	-30 ~ +70	LCP	0.6

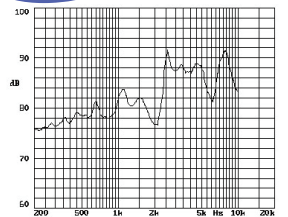

Your Efficient Supplier
www.canopus.com.hk

TEL.: (852) 2806 2812

Fax: (852) 2652 2216

CANOPUS