



CSPEMI607

4-Channel LCD EMI Filter Array with ESD Protection plus 4-Channel of ESD Protection Array

Features

- Four channels of EMI filtering
- Four channels of ESD Protection
- $\pm 15\text{kV}$ ESD protection (IEC 61000-4-2, contact discharge)
- $\pm 30\text{kV}$ ESD protection (HBM)
- Better than 30dB of attenuation at 1GHz for 15pF-100 Ω -15pF filter configuration
- Chip scale packaging features extremely low lead inductance for optimum filter and ESD performance

Applications

- LCD data lines in mobile handsets
- I/O port protection for mobile handsets, notebook computers, PDAs etc.
- EMI filtering for data ports in cell phones, PDAs or notebook computers.

General Description

CAMD's CSPEMI607 is an EMI filter array with ESD protection, which integrates four Pi- filters (C-R-C) and 4 channels of ESD protection. The CSPEMI607 has component values of 15pF-100 Ω -15pF). The parts include avalanche-type ESD diodes on every pin, which provide a very high level of protection for sensitive electronic components that may be subjected to electrostatic discharge (ESD). The ESD diodes connected to the filter ports and the standalone ESD diode channels are designed and characterized to safely dissipate ESD strikes of $\pm 15\text{kV}$, beyond the maximum requirement of the IEC 61000-4-2 international standard. Using the MIL-STD-883 (Method 3015) specification for Human Body Model (HBM) ESD, the pins are protected for contact discharges at greater than $\pm 30\text{kV}$.

This device is particularly well suited for portable electronics (e.g. mobile handsets, PDAs, notebook computers) because of its small package format and easy-to-use pin assignments. In particular, the CSPEMI607 is ideal for EMI filtering and protecting data lines from ESD for the LCD display in mobile handsets.

The CSPEMI607 is available in a space-saving, low-profile, chip-scale package, and is fabricated with one of California Micro Devices' semiconductor processes.

Package Diagram

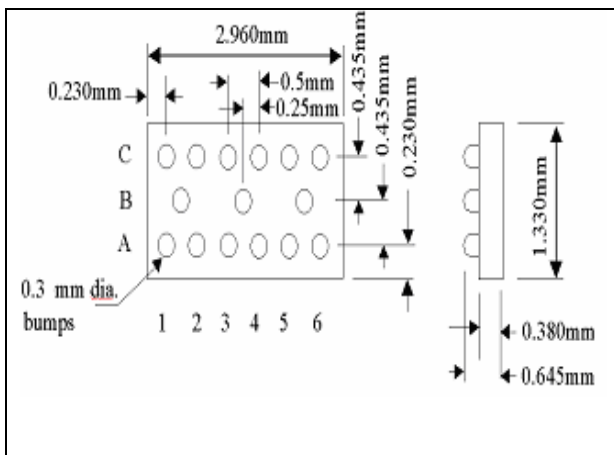
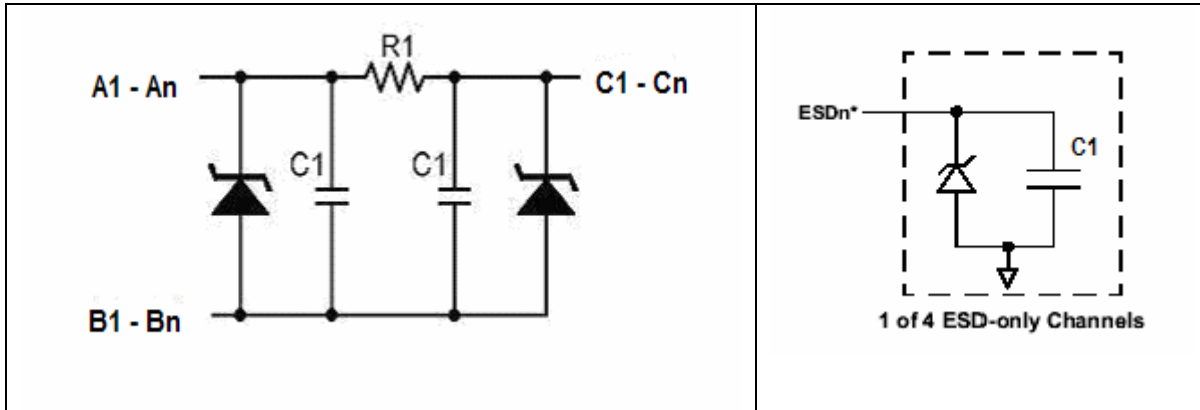



Figure 1. Dimensions of CSPEMI607.

Schematic Diagram



Pin Number	Pin Description	Pin Number	Pin Description
A1	ESD Channel #1	B3	GND
A2	Filter #1	C1	ESD Channel #3
A3	Filter #2	C2	Filter #1
A4	Filter #3	C3	Filter #2
A5	Filter #4	C4	Filter #3
A6	ESD Channel #2	C5	Filter #4
B1	GND	C6	ESD Channel #4
B2	GND		

Specifications: (At 25°C unless specified otherwise)	Min.	Typ.	Max.	Unit
Resistance R1	80	100	120	Ω
Capacitance C1 at 2.5V dc; 1MHz, 30mV ac	12	15	18	pF
Stand-off Voltage, I = 10μA	5.5			V
Diode Leakage at +/-3.3V reverse bias voltage		100		nA
Signal Clamp Voltage:				
Positive Clamp, 10mA	5.6	6.8	9.0	V
Negative Clamp, -10mA	-1.5	-0.8	-0.4	V
In-system ESD withstand voltage*:				
Human Body Model (MIL-STD-883, method 3015)	±30			kV
IEC 61000-4-2, contact discharge method	±15			kV
Clamping voltage during ESD discharge*				
MIL-STD-883 (Method 3015), 8kV		12		V
		-7		V
Temperature Range:				
Operating	-40		85	°C
Storage	-65		150	
DC Power per Resistor:			0.1	W
DC Package Power Rating:			0.5	W

* ESD applied to input / output pins with respect to GND, one at a time. Clamping voltage is measured at the opposite side of the EMI filter to the ESD pin (i.e. if ESD is applied to pin A1 then clamping voltage is measured at pin C1). Unused pins are left open. These parameters are guaranteed by design.



Typical EMI filter performance (2.5V d.c., 50Ω environment)

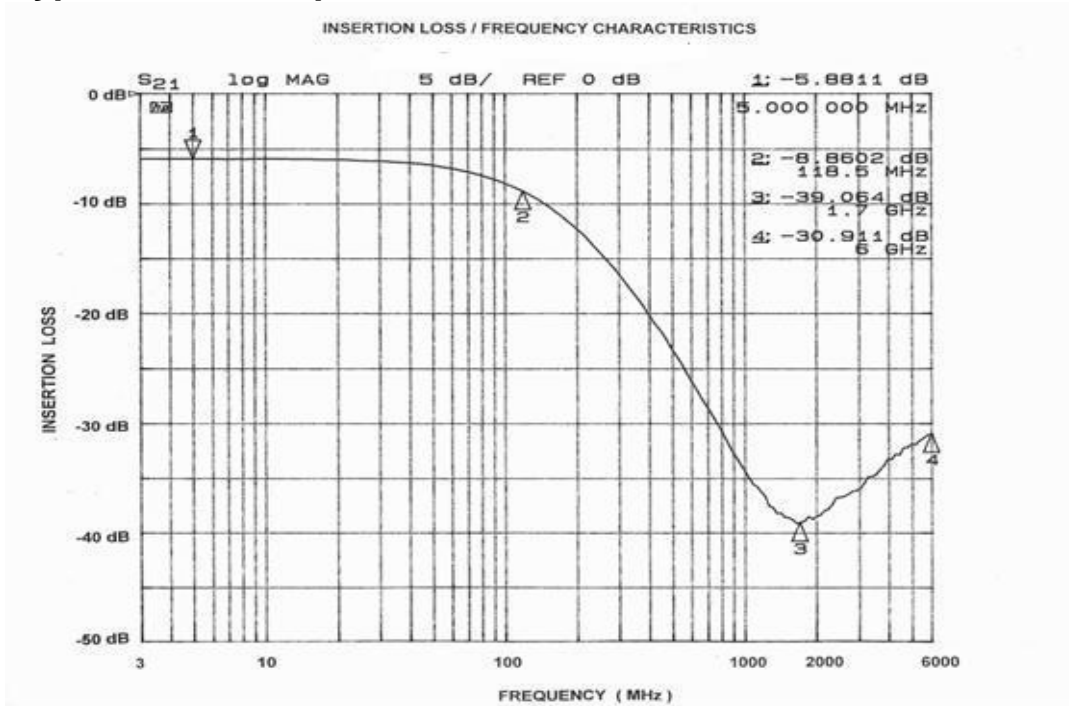

Cut-off Frequency (MHz)	R1 (Ω)	C1 (pF)	20dB Attenuation (MHz)	Over 25dB Range (MHz)
118	100	15	533	738 - 3000

All parameters in the table are typical values.

Typical diode capacitance vs. input voltage (normalized to 2.5V d.c.)

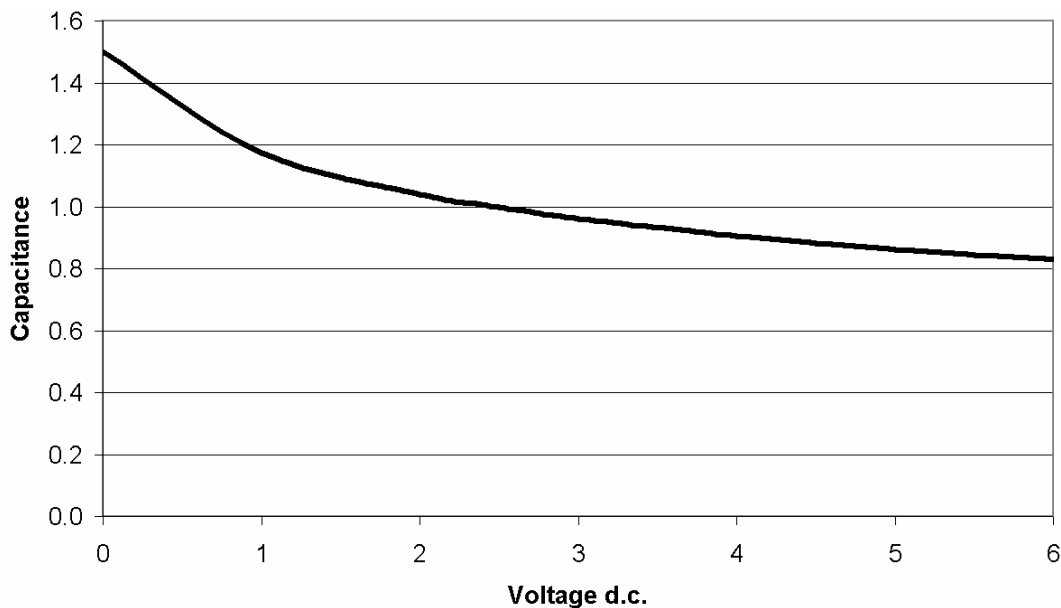



PRINTED CIRCUIT BOARD RECOMMENDATIONS	
Pad size in PCB	0.275mm
Pad Shape	Round
Pad Definition	Non Solder Mask Defined Pads
Solder Mask Opening	0.325mm Round
Solder Stencil Thickness	0.125mm - 0.150mm
Solder Stencil Aperture Opening (Laser cut, 5% tapered walls)	0.330mm (round)
Solder Flux Ratio	50/50 by volume
Solder Paste Type	No Clean
Bond Trace Finish	OSP (Entek Cu Plus 106A)
Tolerance – Edge to Corner Ball	±50µm
Solder Ball Side Coplanarity	±20µm
Soldering Minimum Temperature	205°C for at least 30 seconds
Maximum Dwell Time above Liquidous (183°C)	60 seconds
Soldering Maximum Temperature	240°C for at less than 2 minutes

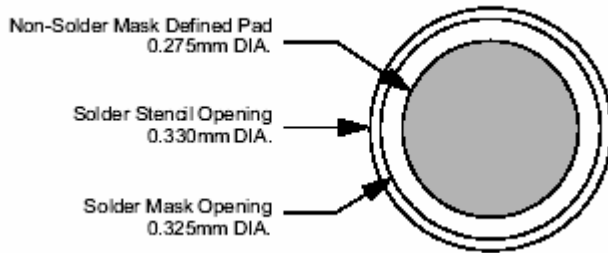

Solder Reflow Profile

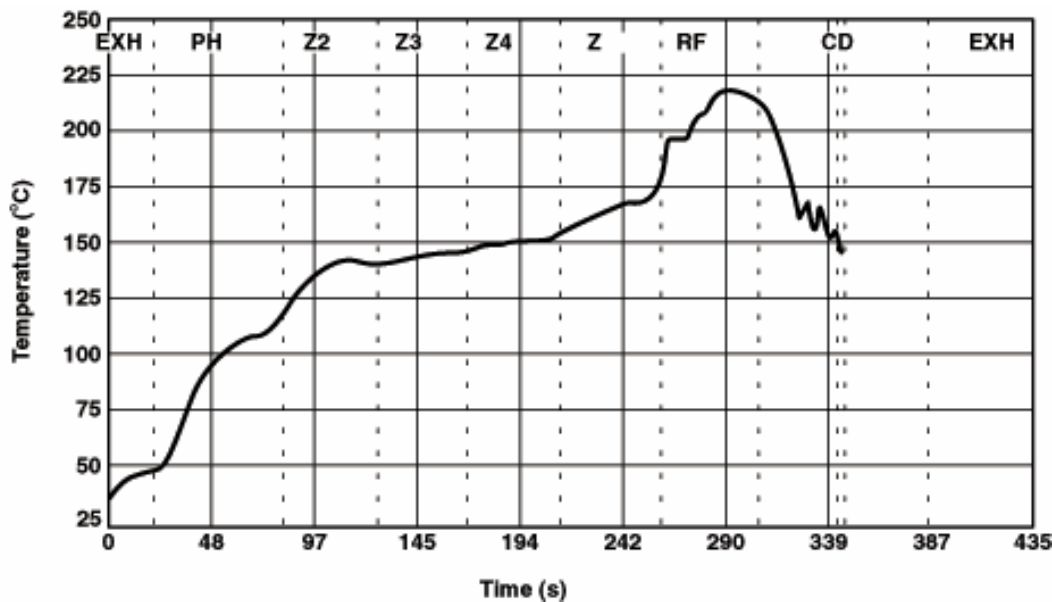



Tape & Reel Information

CMD PART #	CHIP SIZE (mm)	POCKET SIZE (mm) Bo x Ao x Ko	TAPE WIDTH W	REEL DIAMETER	QTY PER REEL	P ₀	P ₁
CSPEMI607	2.96 x 1.33 x 0.6	TBD	8mm	178mm (7")	3500	4mm	4mm

