



CST80P03 P-Ch 30V Fast Switching MOSFETs

- ★ 100% EAS Guaranteed
- ★ Green Device Available
- ★ Super Low Gate Charge
- ★ Excellent CdV/dt effect decline
- ★ Advanced high cell density Trench technology

CST80P03 Product Summary

BVDSS	RDSON	ID
-30V	6.0mΩ	-80A

CST80P03 Description

The CST80P03 is the high cell density trenched P-ch MOSFETs, which provide excellent RDSON and gate charge for most of the synchronous buck converter applications.

The CST80P03 meet the RoHS and Gree Product requirement 100% EAS guaranteed with full function reliability approved.

CST80P03 TO252 Pin Configuration

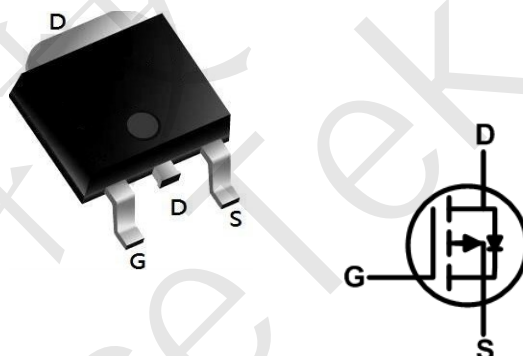

CST80P03 Absolute Maximum Ratings

Parameter		Symbol	Value	Unit
Drain-Source Voltage		V_{DS}	-30	V
Gate-Source Voltage		V_{GS}	±20	V
Continuous Drain Current@-10V ¹	$T_C=25^{\circ}C$	I_D	-80	A
	$T_C=75^{\circ}C$		-42	
Pulsed Drain Current ²		I_{DM}	-175	A
Single Pulse Avalanche Energy ³		EAS	31	mJ
Avalanche Current		I_{AS}	-25	A
Total Power Dissipation ⁴	$T_C=25^{\circ}C$	P_D	31.2	W
Operating Junction and Storage Temperature Range		T_J, T_{STG}	-55 to+150	°C

Thermal Characteristics

Parameter	Symbol	Value	Unit
Thermal Resistance from Junction-to-Ambient ¹	$R_{\theta JA}$	43	°C/W
Thermal Resistance from Junction-to-Case ¹	$R_{\theta JC}$	4	°C/W



CST80P03 Electrical Characteristics $T_c = 25^\circ\text{C}$, unless otherwise noted

Parameter	Symbol	Test Conditions	Min.	Typ.	Max.	Unit
Static Characteristics						
Drain-Source Breakdown Voltage	$V_{(BR)DSS}$	$V_{GS} = 0V, I_D = -250\mu A$	-30	-	-	V
Gate-body Leakage current	I_{GSS}	$V_{DS} = 0V, V_{GS} = \pm 20V$	-	-	± 100	nA
Zero Gate Voltage Drain Current	$T_J = 25^\circ\text{C}$	$V_{DS} = -24V, V_{GS} = 0V$	-	-	-1	μA
	$T_J = 55^\circ\text{C}$		-	-	-5	
Gate-Threshold Voltage	$V_{GS(th)}$	$V_{DS} = V_{GS}, I_D = -250\mu A$	-1.0	-1.6	-2.5	V
Drain-Source On-Resistance ²	$R_{DS(on)}$	$V_{GS} = -10V, I_D = -12A$	-	6	8.8	m Ω
		$V_{GS} = -4.5V, I_D = -8A$	-	9	14	
Forward Transconductance	g_{fs}	$V_{DS} = -5V, I_D = -20A$	-	28	-	S
Dynamic Characteristics						
Input Capacitance	C_{iss}	$V_{DS} = -15V, V_{GS} = 0V, f = 1\text{MHz}$	-	4320	-	pF
Output Capacitance	C_{oss}		-	529	-	
Reverse Transfer Capacitance	C_{rss}		-	487	-	
Switching Characteristics						
Gate Resistance	R_g	$V_{DS} = 0V, V_{GS} = 0V, f = 1.0\text{MHz}$	-	4.0	-	Ω
Total Gate Charge	Q_g	$V_{GS} = -10V, V_{DS} = -15V, I_D = -15A$	-	45	-	nC
Gate-Source Charge	Q_{gs}		-	8.5	-	
Gate-Drain Charge	Q_{gd}		-	12.8	-	
Turn-On Delay Time	$t_{d(on)}$	$V_{GS} = -10V, V_{DD} = -15V, R_G = 2.5\Omega, I_D = -15A$	-	18.9	-	nS
Rise Time	t_r		-	15.7	-	
Turn-Off Delay Time	$t_{d(off)}$		-	64.8	-	
Fall Time	t_f		-	36.5	-	
Drain-Source Body Diode Characteristics						
Diode Forward Voltage ²	V_{SD}	$I_S = -1A, V_{GS} = 0V$	-	-	-1	V
Continuous Source Current ^{1,5}	I_S	$V_G = V_D = 0V$, Force Current	-	-	-80	A

Note :

- 1.The data tested by surface mounted on a 1 inch² FR-4 board with 2OZ copper.
- 2.The data tested by pulsed , pulse width $\leq 300\mu s$, duty cycle $\leq 2\%$
- 3.The EAS data shows Max. rating . The test condition is $V_{DD} = -25V, V_{GS} = -10V, L = 0.1\text{mH}, I_{AS} = -25A$
- 4.The power dissipation is limited by 150°C junction temperature
- 5.The data is theoretically the same as I_D and I_{DM} , in real applications , should be limited by total power dissipation.

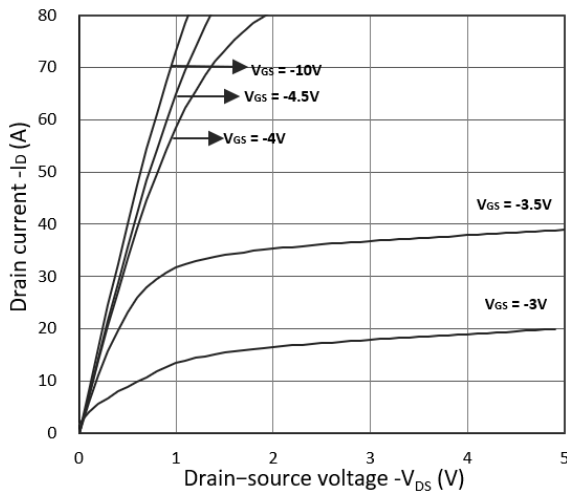

Figure 1. Output Characteristics

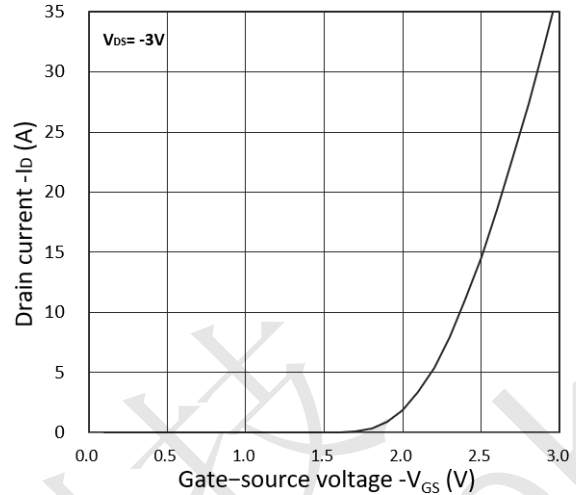

Figure 2. Transfer Characteristics

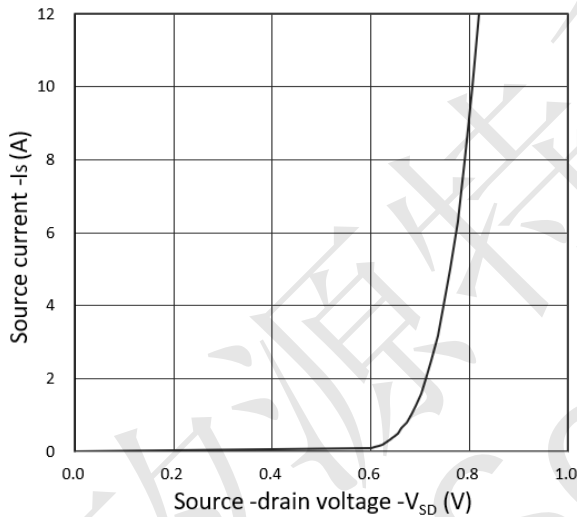

Figure 3. Forward Characteristics of Reverse

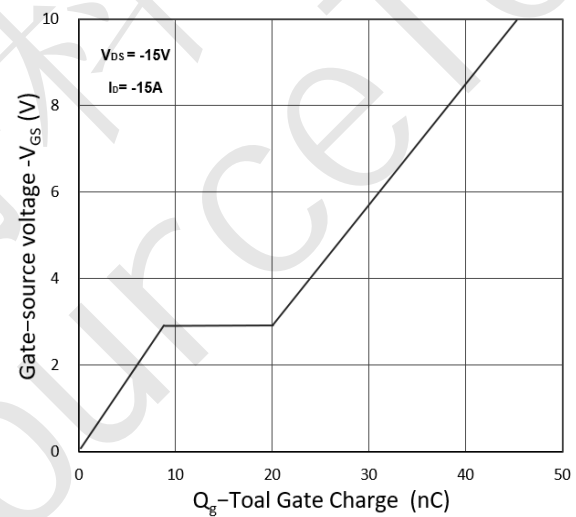

Figure 4. Gate Charge Characteristics

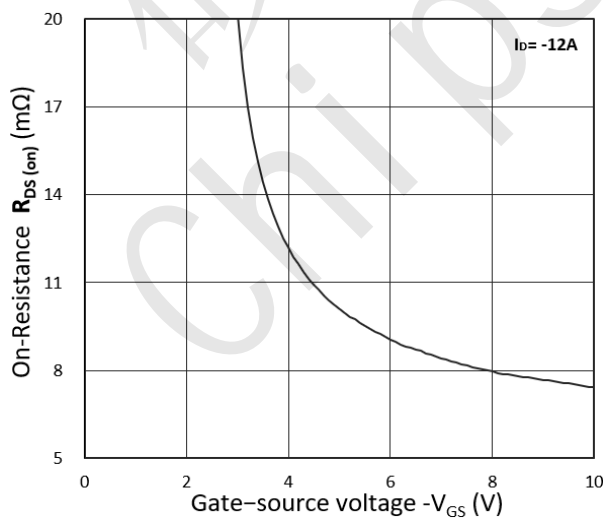

Figure 5. $R_{DS(on)}$ vs. V_{GS}

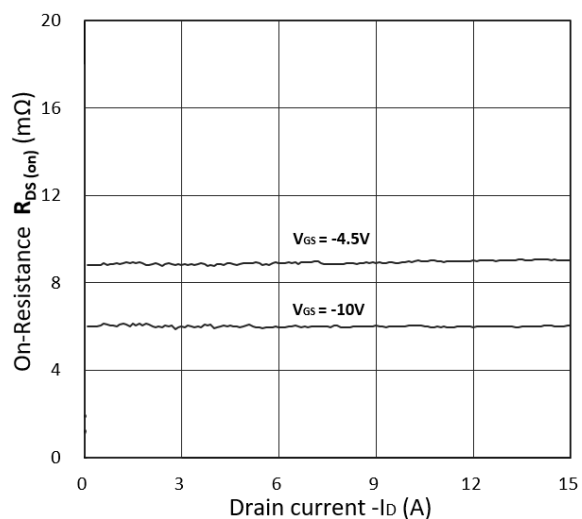

Figure 6. $R_{DS(on)}$ vs. I_D

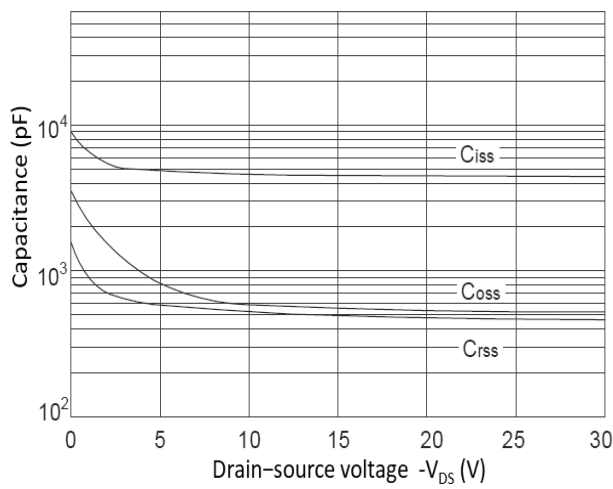

Figure 7. Capacitance Characteristics

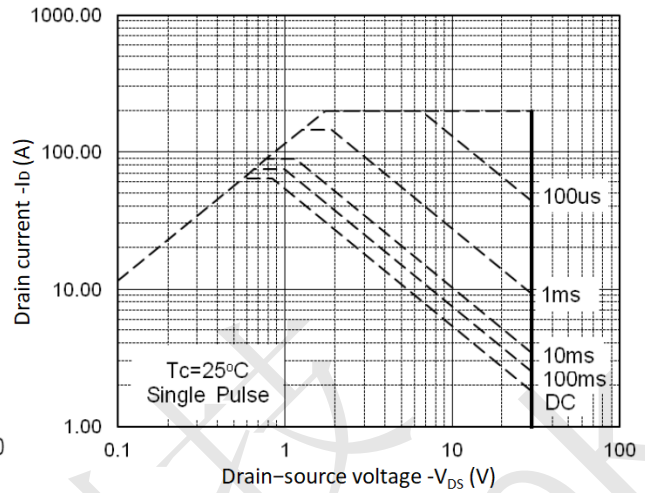

Figure 8. Safe Operating Area

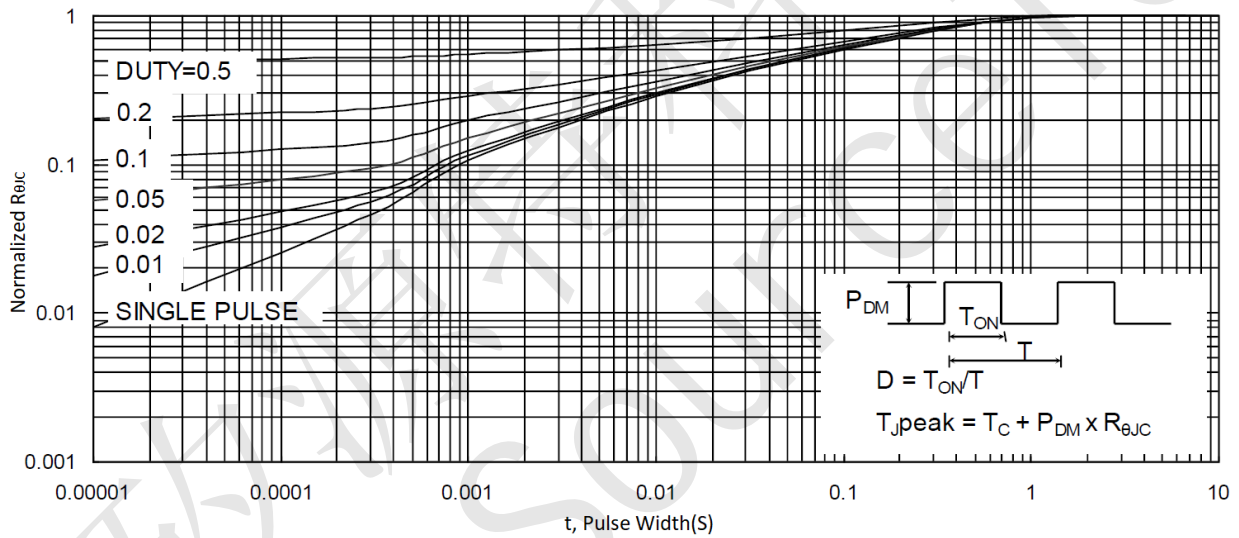

Figure 9. Normalized Maximum Transient Thermal Impedance

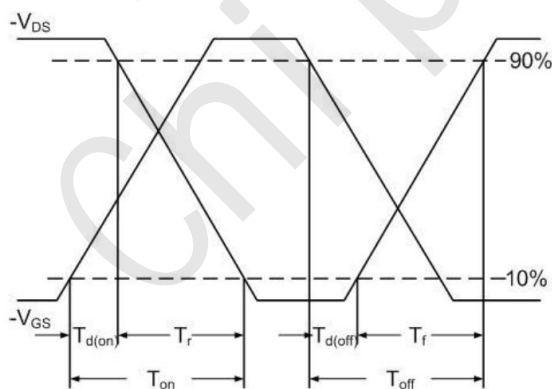

Figure 10. Switching Time Waveform

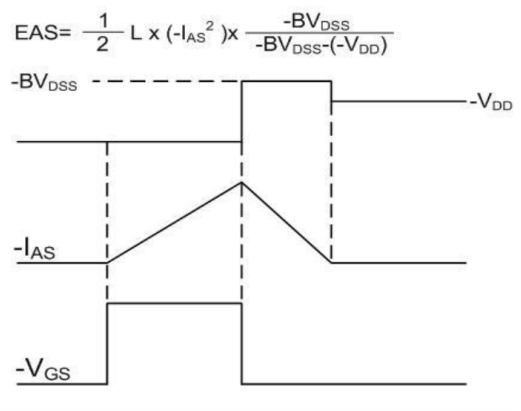
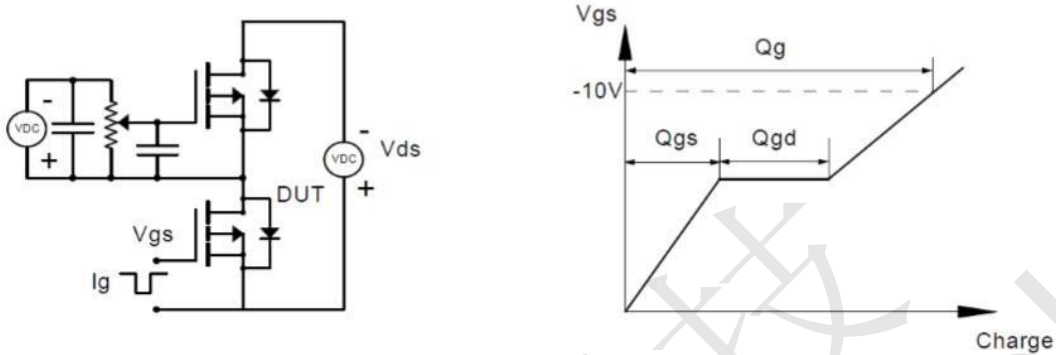

Figure 11. Unclamped Inductive Switching Waveform



CST80P03 Test Circuit

Gate Charge Test Circuit & Waveform



Resistive Switching Test Circuit & Waveforms

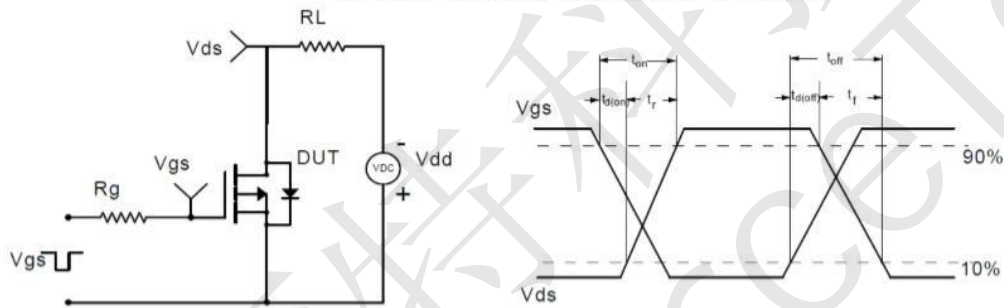

Unclamped Inductive Switching (UIS) Test Circuit & Waveforms

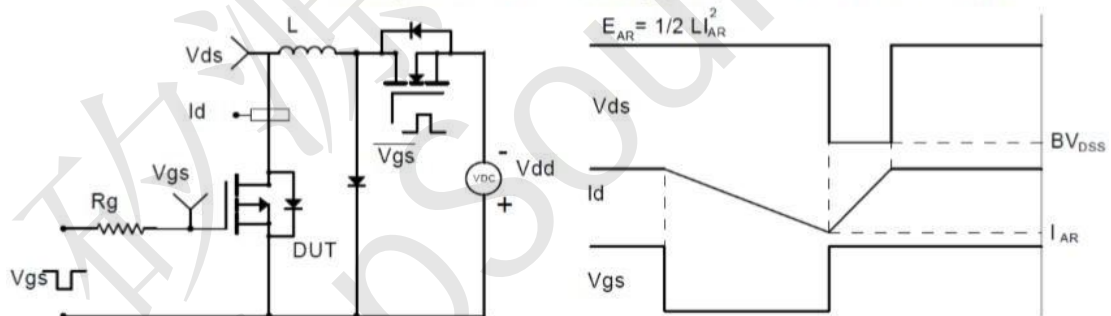

Diode Recovery Test Circuit & Waveforms

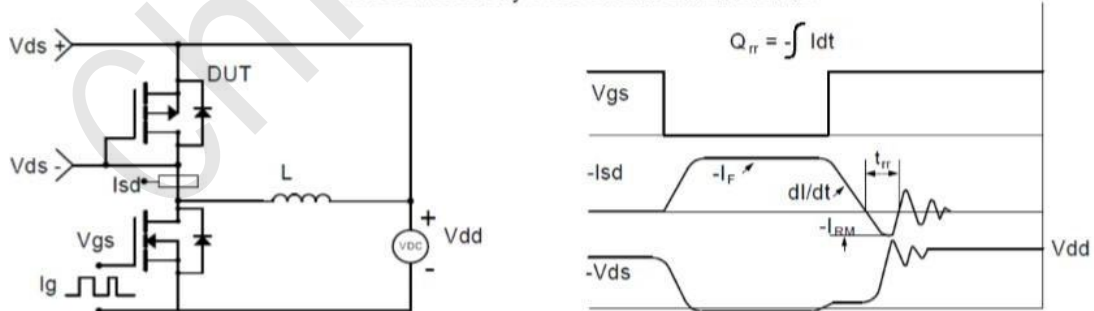



CST80P03 TO-252 Package outline

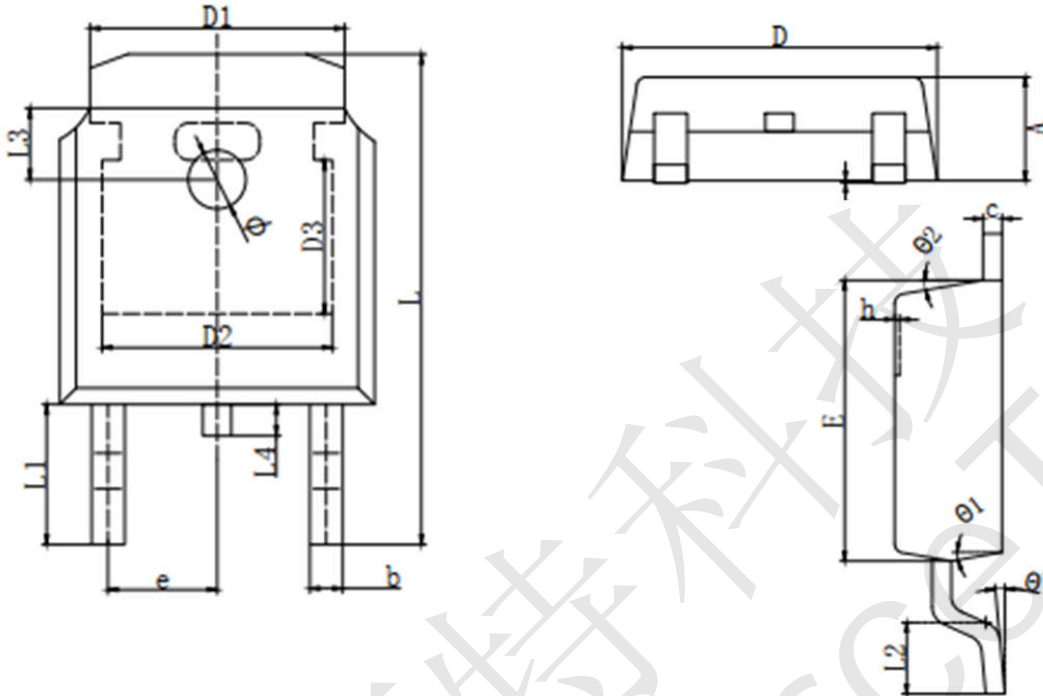

SYMBOL	MILLIMETER		SYMBOL	MILLIMETER	
	MIN	MAX		MIN	MAX
A	2.200	2.400	h	0.000	0.200
A1	0.000	0.127	L	9.900	10.30
b	0.640	0.740	L1	2.888 REF	
c	0.460	0.580	L2	1.400	1.700
D	6.500	6.700	L3	1.600 REF	
D1	5.334 REF		L4	0.600	1.000
D2	4.826 REF		ϕ	1.100	1.300
D3	3.166 REF		θ	0°	8°
E	6.000	6.200	$\theta 1$	9° TYP2	
e	2.286 TYP		$\theta 2$	9° TYP	