

0.5-18 GHz GaAs pHEMT MMIC SPDT Switch

Features

- ✗ Broadband Coverage: 0.5 to 18.0 GHz
- ✗ Insertion Loss: 1.8 dB Typ. @ 10 GHz
- ✗ Isolation: 35 dB
- ✗ P1dB: +20 dBm, Typical
- ✗ Current Consumption: 50 μ A, Typ. with Control Voltage of -7.0V, 0.0V
- ✗ 2 nsec Rise/Fall Time
- ✗ 0.5 μ m pHEMT Technology
- ✗ Small Size: 670 x 590 x 76 μ m (26.4 x 23.2 x 3.0 mil)

Applications

- ✗ Radar
- ✗ Communications
- ✗ Avionics
- ✗ Test and Measurement

Description

The CSW0118-BD is a single-pole double-throw (SPDT) GaAs pHEMTMMIC switch that covers the frequency range from 0.5 to 18 GHz. The CSW0118-BD is 80% smaller than comparable broadband FETswitch MMICs offering similar performance. It has very low power consumption requirements and offers very fast switching speeds. The 0.5 μ m pHEMT GaAs process used for this device provides for excellent uniformity and high manufacturing yields.

Chip Diagram

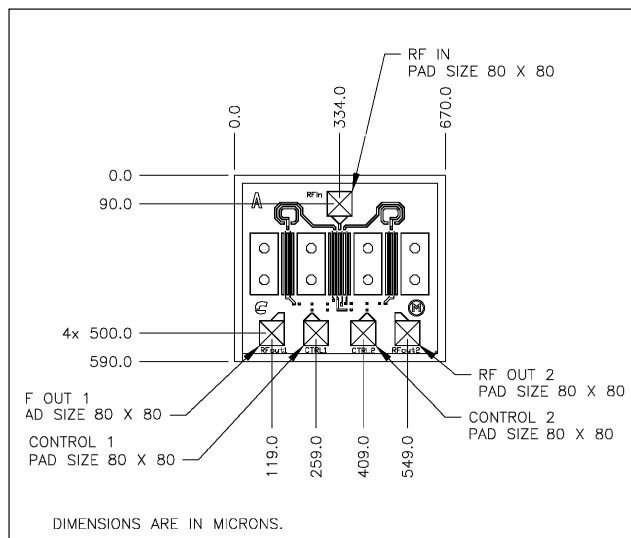

Backside via holes are used to provide low inductance ground connections and to facilitate ease of use. Gold-plated metallization is used on both front side and backside metal. The MMIC is compatible with either eutectic or conductive epoxy die attach and either thermocompression or thermosonic wire bonding. Minimal off-chip components provides ease of use in design and manufacturing steps.

CSW0118-BD SPDTMMIC switches are shipped in Gel Pack.

Specifications ($T_A = 25^\circ\text{C}, V_{DD} = 0.0\text{V}$)

Parameters	Units	Min	Typ	Max
Frequency Range	GHz	0.5		18.0
Vp (Vds = 3.0V, Id = 1 mA)	Volts	-1.5	-1.0	-0.5
BVdg0 (100 μ A/mm)	Volts	16.0	19.0	
Idss (Vds = 3.0V)	mA/mm		150	

RFSpecifications at Frequency ($T_A = 25^\circ\text{C}$)

Parameters	@ 0.5 GHz	@ 2.0 GHz	@ 10.0 GHz	@ 18.0
Insertion Loss, dB	1.4	1.6	1.8	2.7
Isolation, dB	-40	-30	-23	-24
P-1dB, dBm	20.0	21.5	21.0	21.5
VSWR In/Out	2.5:1	1.5:1	1.5:1	1.5:1

0.5-18 GHz GaAs pHEMT MMIC SPDT Switch

Absolute Maximum Ratings

Parameter	Rating
Input Power (Pin)	≥ +30 dBm
Control Voltage (Vctrl)	-10 V (min.) 0.0V (max)
Operating Channel Temperature	+150°C
Mounting Temperature	+320°C
Storage Temperature	-65°C to +150°C

Die Attach and Bonding Procedures

Die Attach: Eutectic die attach is recommended. For eutectic die attach: Preform: AuSn (80% Au, 20% Sn); Stage Temperature: 290°C, ±5°C; Handling Tool: Tweezers; Time: 1 min or less.

Wire Bonding: Wire Size: 0.7 to 1.0 mil in diameter (pre-stressed); Thermocompression or thermosonic bonding is acceptable. For thermocompression bonding: Stage Temperature: 250°C; Bond Tip Temperature: 150°C; Bonding Tip Pressure: 18 to 40 gms depending on size of wire.

Biasing and Operation

No voltage is required at the RF input or RF output ports to turn the switch "ON." The control voltage for the desired through path should be set to 0.0V in order to turn that leg of the switch "ON." The control voltage of the isolated path should be set to a negative voltage exceeding -1.5V (more negative than -1.5V). As the voltage of the isolated path control voltage pad is taken more negative the isolation will improve up to the voltage limit of -7.0V. See the following Truth Table for an explanation of how to set the through path and the isolated path of the switch.

Truth Table

Vctrl 1	Vctrl 2	Path 1	Path 2
-2.0V	0.0V	OFF	ON
0.0V	-2.0V	ON	OFF

Schematic Diagram

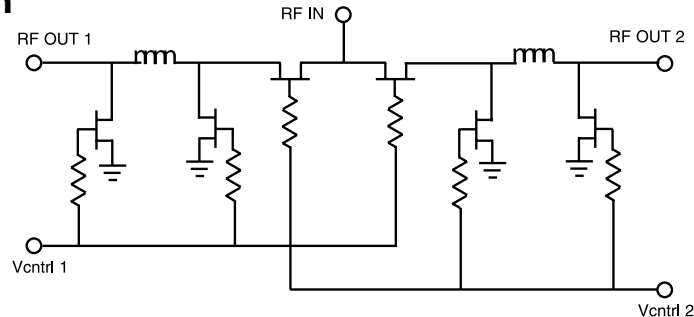

Bonding Diagram

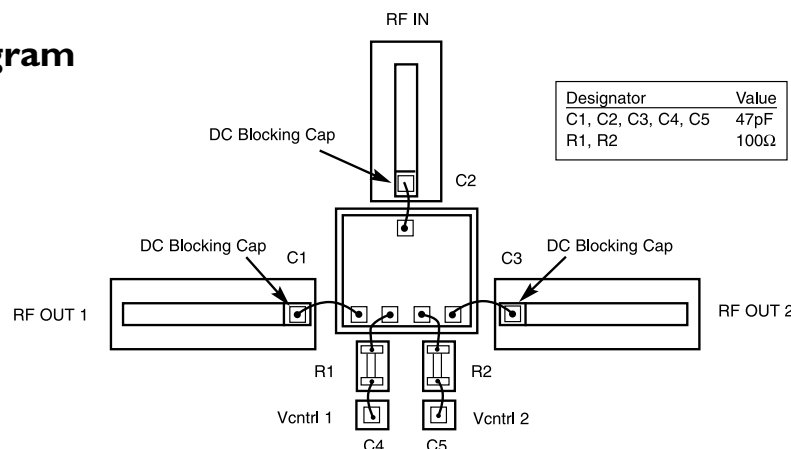

0.5-18 GHz GaAs pHEMT MMIC SPDT Switch

Typical Performance

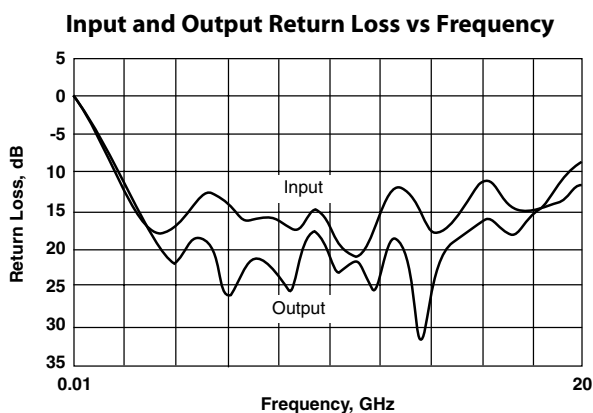
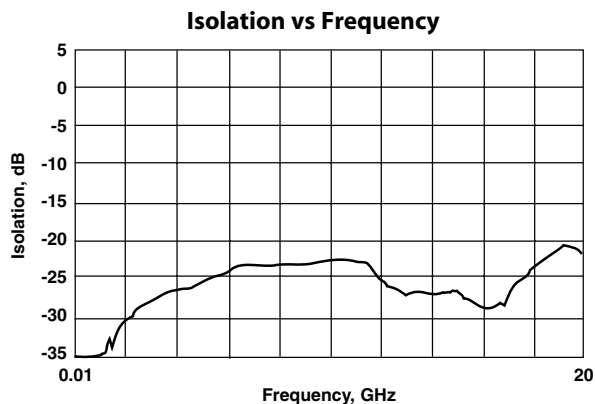
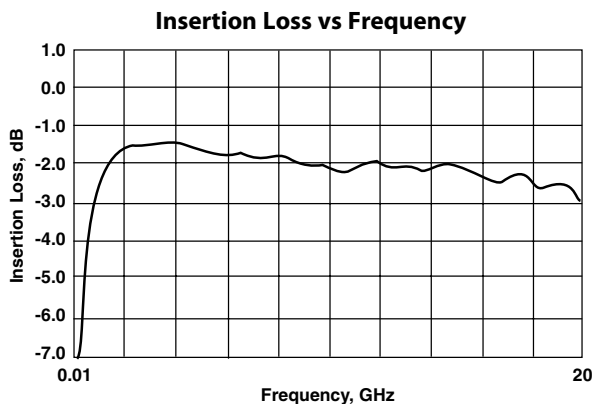

0.5-18 GHz GaAs pHEMT MMIC SPDT Switch



CSW0118-BD

January 2007 - Rev 22-Jan-07

Handling and Assembly Information

CAUTION! - Mimix Broadband MMIC Products contain gallium arsenide (GaAs) which can be hazardous to the human body and the environment. For safety, observe the following procedures:

- *Do not ingest.*
- *Do not alter the form of this product into a gas, powder, or liquid through burning, crushing, or chemical processing as these by-products are dangerous to the human body if inhaled, ingested, or swallowed.*
- *Observe government laws and company regulations when discarding this product. This product must be discarded in accordance with methods specified by applicable hazardous waste procedures.*

Life Support Policy - Mimix Broadband's products are not authorized for use as critical components in life support devices or systems without the express written approval of the President and General Counsel of Mimix Broadband. As used herein: (1) Life support devices or systems are devices or systems which, (a) are intended for surgical implant into the body, or (b) support or sustain life, and whose failure to perform when properly used in accordance with instructions for use provided in the labeling, can be reasonably expected to result in a significant injury to the user. (2) A critical component is any component of a life support device or system whose failure to perform can be reasonably expected to cause the failure of the life support device or system, or to affect its safety or effectiveness.

ESD - Gallium Arsenide (GaAs) devices are susceptible to electrostatic and mechanical damage. Die are supplied in anti-static containers, which should be opened in cleanroom conditions at an appropriately grounded antistatic workstation. Devices need careful handling using correctly designed collets, vacuum pickups or, with care, sharp tweezers.

Die Attachment - GaAs Products from Mimix Broadband are 0.100 mm (0.004") thick and have vias through to the back-side to enable grounding to the circuit. Microstrip substrates should be brought as close to the die as possible. The mounting surface should be clean and flat. If using conductive epoxy, recommended epoxies are Tanaka TS3332LD, Die Mat DM6030HK or DM6030HK-Pt cured in a nitrogen atmosphere per manufacturer's cure schedule. Apply epoxy sparingly to avoid getting any on to the top surface of the die. An epoxy fillet should be visible around the total die periphery. For additional information please see the Mimix "Epoxy Specifications for Bare Die" application note. If eutectic mounting is preferred, then a fluxless gold-tin (AuSn) preform, approximately 0.001² thick, placed between the die and the attachment surface should be used. A die bonder that utilizes a heated collet and provides scrubbing action to ensure total wetting to prevent void formation in a nitrogen atmosphere is recommended. The gold-tin eutectic (80% Au 20% Sn) has a melting point of approximately 280° C (Note: Gold Germanium should be avoided). The work station temperature should be 310°C +/- 10° C. Exposure to these extreme temperatures should be kept to minimum. The collet should be heated, and the die pre-heated to avoid excessive thermal shock. Avoidance of air bridges and force impact are critical during placement.

Wire Bonding - Windows in the surface passivation above the bond pads are provided to allow wire bonding to the die's gold bond pads. The recommended wire bonding procedure uses 0.076 mm x 0.013 mm (0.003" x 0.0005") 99.99% pure gold ribbon with 0.5-2% elongation to minimize RF port bond inductance. Gold 0.025 mm (0.001") diameter wedge or ball bonds are acceptable for DC Bias connections. Aluminum wire should be avoided. Thermo-compression bonding is recommended though thermosonic bonding may be used providing the ultrasonic content of the bond is minimized. Bond force, time and ultrasonics are all critical parameters. Bonds should be made from the bond pads on the die to the package or substrate. All bonds should be as short as possible.

Ordering Information

The CSW0118-BD is available in bare die and is shipped in Gel Pak.

<u>Part Number for Ordering</u>	<u>Description</u>
CSW0118-BD	Bare Die

Mimix Broadband, Inc., 10795 Rockley Rd., Houston, Texas 77099
Tel: 281.988.4600 Fax: 281.988.4615 mimixbroadband.com

Page 4 of 4