

MODEL NUMBER CSW18066

Switch SPST

FEATURES

- 240-2800 MHz
- Flat Pack
- 88 db Isolation

- 300 nSec Switching Speed
- +44 dBm 3rd Order Intercept Point

SPST

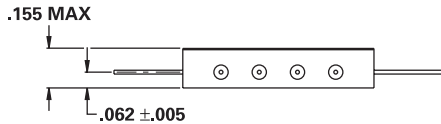
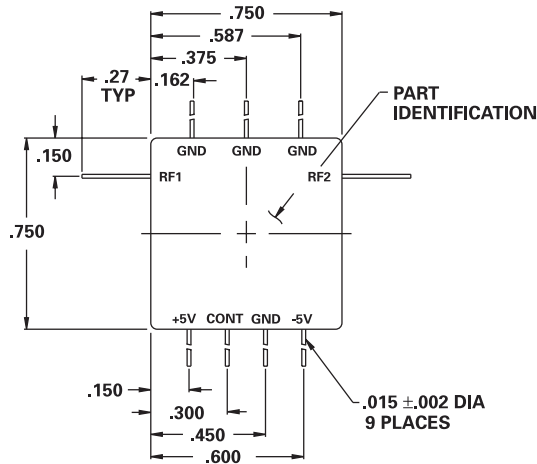

.xx = .02
.xxx = .010

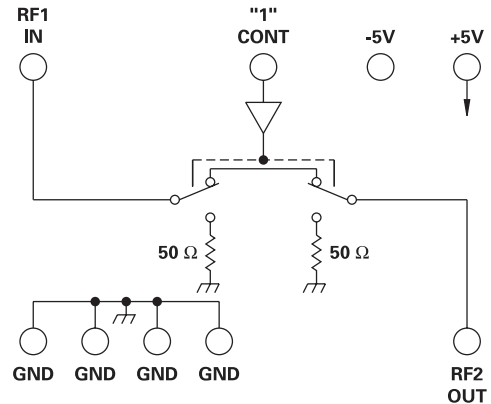

GUARANTEED PERFORMANCE

Parameter	Min	Typ	Max	Units	Conditions
Operating Frequency	240		2800	MHz	
DC Current		9.1 0	15 3	mA mA	At +5 VDC Supply At -5 VDC Supply
Control Type		TTL			1 Line Logic "0" = Isolation Logic "1" = Thru
Control Current	High Low	±1.0 ±1.0	±10 ±10	μA μA	V _{IH} = +2.7 V V _{IL} = +0.5 V
Insertion Loss			1.5 2.0	dB	
Isolation		65	88	dB	
VSWR	Thru Termination	1.07/1 1.07/1	1.4/1 1.4/1		
Impedance			50	OHMS	
Switching Speed		127	300	nSec	50% TTL to 90% / 10% RF
Switching (Video) Transients			450	mV	Peak Value
Intercept Points	2nd 3rd	+60 +30	+63 +44	dBm dBm	
RF Power	Operate No Damage		+23 0 +30	dBm dBm	0.1 dB Compression
Operating Temperature		-20	+25	+70	°C TA
Storage Temperature		-45		+85	°C TA

TYPICAL PERFORMANCE at 25°C

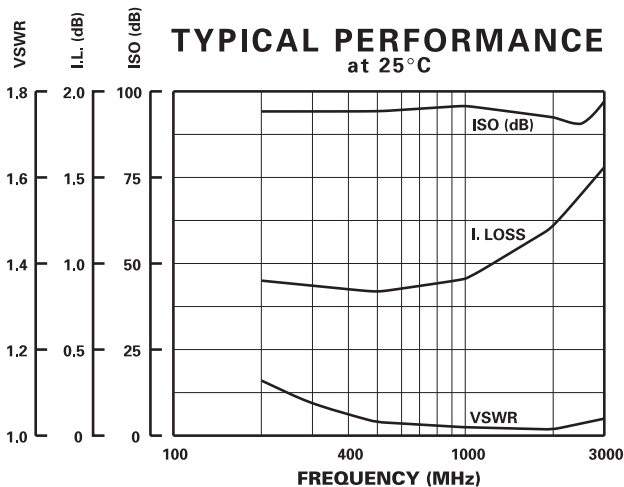

DAICO Industries

310.507.3242 • FAX 310.507.5701 • www.daico.com