

INNOLUX DISPLAY CORPORATION

LCD MODULE

SPECIFICATION

Customer: _____
Model Name: CT025TN01
Spec. No.: C025-01-TT-01
Data: 2008/01/02
Version: 04

Preliminary Specification

Final Specification

For Customer's Acceptance

Approved by	Comment

Approved by	Reviewed by	Prepared by
Rock Chi 2008/01/10	Jack Huang 2008/01/07	Kevin Chen 2008/01/07

The copyright belongs to InnoLux. Any unauthorized use is prohibited.

The copyright belongs to INNOLUX. Any unauthorized use is prohibited.

Record of Revision

Version	Revise Date	Page	Content
Pre-SPEC 01	2007/02/16	All	Initial release
02	2007/02/27	1,6,13	Color arrangement change to RGB-stripe
03	2007/04/19	2	Update Block Diagram
		3	Update Pin Assignment
		15	Update Mechanical Drawing
04	2007/06/15	1	Update General Specifications
		2	Update Block Diagram
		5~9	Update Electrical Specifications
		8	Update VDD
		12	Add the tolerance of the white Color chromaticity
		19	Update the lable of Mechanical Drawing
Final-SPEC 01	2007/07/04	1	Update General Specifications
		3	Modify Pin 7 from NC to VCOMH
			Add remark for pin 7 and pin 8
		12	Add Min. Values of Color Gamut
			Add Min. Values of Luminance Uniformity
			Add Min. Values of Viewing Angle
		17	Update Note1 and Note2
		19	Add DC number of the Mechanical Drawing
		20,21	Add Package Drawing
02	2007/08/16	8	Add Power on sequence
03	2007/12/07	1	Modify Weight Specification
		14	Modify Fig. 1 Definition of uniformity
		16	Modify Fig. 2 Definition of viewing direction for display
		19	Modify Mechanical Drawing
		20	Modify Weight Specification
04	2008/01/02	19	Modify Mechanical Drawing

Contents

1.	General Specifications.....	1
2.	Block Diagram.....	2
3.	Pin Assignments.....	3
4.	Electrical Specifications.....	5
4.1.	Absolute Maximum Ratings.....	5
4.2.	Typical Operation Conditions.....	5
4.3.	Backlight Unit (LED Type).....	7
4.4.	Instruction List.....	7
4.5.	Instruction Setting Flow.....	8
4.6.	Timing Characteristics.....	9
4.6.1	SPI Interface Timing.....	9
4.6.2	Parallel RGB Interface Timing.....	10
5.	Optical Specifications.....	12
6.	Reliability Test Items.....	17
7.	Handling Precautions.....	18
7.1	Safety.....	18
7.2	Handling.....	18
7.3	Static Electricity.....	18
7.4	Storage.....	18
7.5	Cleaning.....	18
8	Mechanical Drawing.....	19
9	Package Drawing.....	20
9.1.	Packaging Material Table.....	20
9.2.	Packaging Quantity.....	20
9.3.	Package Drawing.....	21

1. General Specifications

1.1. Description

The CT025TN01 is a color active matrix Thin Film Transistor (TFT) Liquid Crystal Display (LCD) that uses amorphous silicon (a-Si) TFT as a switching device. This module is composed of a single 2.5 inches transmissive type main TFT-LCD Panel. The resolution of the panel is 320x240 pixels and can display 262K color.

1.2. Features:

- TM type for main TFT-LCD panel
- One backlight with 3 white LED
- RGB interface
- Full, Still & Standby mode are available

1.3. Application:

- Display terminals for host computer

1.4. General Specifications

No.	Item	Specification	Unit	Remark
1	LCD Size	2.5 (diagonal)(landscape)	Inch	-
2	Panel Type	a-Si TFT	-	-
3	Resolution	320(RGB) x 240	Pixel	-
4	Display Mode	Normally white, Transmissive	-	-
5	Display Number of Colors	262 K	-	-
6	Viewing Direction	12 o'clock	-	Note 1
7	Module Size	56.40(W) x 49.12(L) x 2.70(T)	mm	Note 1
8	Active Area	49.92(W) x 37.44(L)	mm	-
9	Pixel Pitch	52 x 156	um	-
10	Weight	15.4	g	-
11	Color Arrangement	RGB Stripe	-	-
12	Polarizer Surface Treatment	Hard Coating	-	-
13	Driver IC	ILI9322	-	-
14	Light Source	3 white LEDs	-	-
15	Interface	RGB	-	-

Note 1: Refer to mechanical drawing.

The copyright belongs to InnoLux. Any unauthorized use is prohibited

版權屬於群創所有。禁止任何未經授權的使用

The copyright belongs to INNOLUX. Any unauthorized use is prohibited.

2. Block Diagram

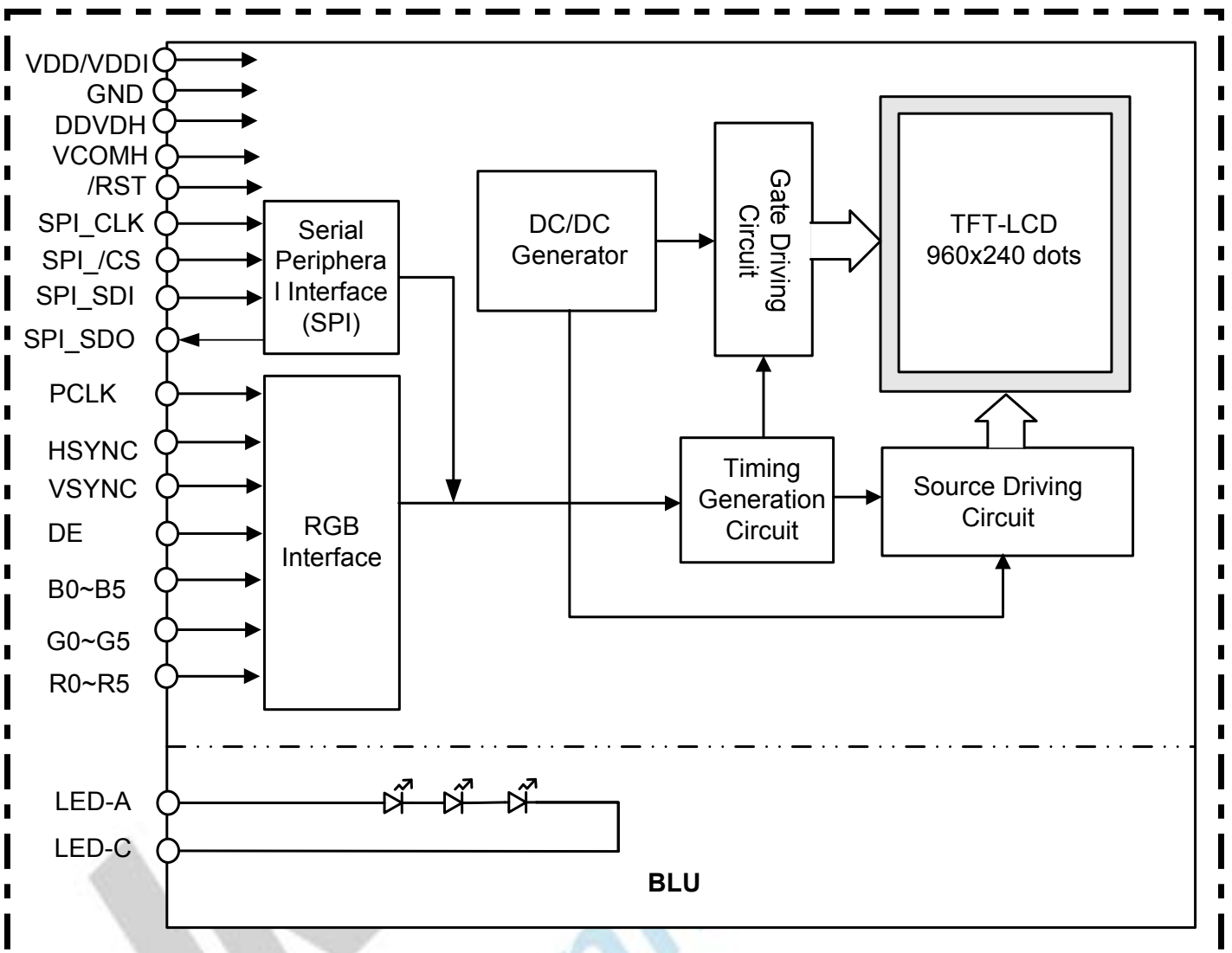

The copyright belongs to InnoLux. Any unauthorized use is prohibited

版權屬於群創所有，禁止任何未經授權的使用

The copyright belongs to INNOLUX. Any unauthorized use is prohibited.

3. Pin Assignments

(ZIF Molex SD-54393-3918)

Pin No.	Symbol	I/O	Function	Remark
1	LED-A	P	Anode for LEDs	-
2	LED-C	P	Cathode for LEDs	-
3	VDDI	P	Voltage input for I/O logic	-
4	VDD	P	Voltage supply pin for analog circuit	-
5	GND	P	Ground	-
6	GPIO	P	Ground	-
7	VCOMH	P	Test pad for OTP	Only for Innolux
8	DDVDH	P	Power supply for OTP	Only for Innolux
9	NC	-	-	-
10	SPI_/CS	I	Chip select pin of serial interface	-
11	SPI_SDI	I	Data input pin in serial mode	-
12	SPI_SDO	O	Data output pin in serial mode	-
13	SPI_CLK	I	Clock pin of serial interface	-
14	NC	-	-	-
15	/RST	I	Reset Signal Pin	-
16	B0	I	Blue Data (Bit 0)	-
17	B1	I	Blue Data (Bit 1)	-
18	B2	I	Blue Data (Bit 2)	-
19	B3	I	Blue Data (Bit 3)	-
20	B4	I	Blue Data (Bit 4)	-
21	B5	I	Blue Data (Bit 5)	-
22	G0	I	Green Data (Bit 0)	-
23	G1	I	Green Data (Bit 1)	-
24	G2	I	Green Data (Bit 2)	-
25	G3	I	Green Data (Bit 3)	-
26	G4	I	Green Data (Bit 4)	-
27	G5	I	Green Data (Bit 5)	-
28	R0	I	Red Data (Bit 0)	-
29	R1	I	Red Data (Bit 1)	-
30	R2	I	Red Data (Bit 2)	-
31	R3	I	Red Data (Bit 3)	-

The copyright belongs to InnoLux. Any unauthorized use is prohibited

版權屬於群創所有。禁止任何未經授權的使用

The copyright belongs to INNOLUX. Any unauthorized use is prohibited.

32	R4	I	Red Data (Bit 4)	
33	R5	I	Red Data (Bit 5)	-
34	GND	P	Ground	-
35	PCLK	I	Dot-clock signal	-
36	GND	P	Ground	
37	VSYNC	I	Frame synchronization signal	
38	HSYNC	I	Line synchronization signal	
39	DE	I	Display enable pin	

INNO LUX
Confidential

The copyright belongs to InnoLux. Any unauthorized use is prohibited

版權屬於群創所有。禁止任何未經授權的使用

The copyright belongs to INNOLUX. Any unauthorized use is prohibited.

4. Electrical Specifications

4.1. Absolute Maximum Ratings

Item		Symbol	Values		Unit	Remark
			Min.	Max.		
TFT Module	Logic Supply Voltage	VDDI	-0.3	+4.6	V	Note 1
	Analog Supply Voltage	VDD	-0.3	+4.6	V	Note 1
Backlight Unit	Current	I _B	-	30	mA	Note 2
	Power Consumption	P _{BL}	-	324	mW	Note 2

Note1: Permanent damage to the device may occur if maximum values are exceeded or reverse voltage is applied.

Note2: Without LED driver IC, please refer to 4.3.

4.2. Typical Operation Conditions

4.2.1 DC Characteristics

(Ta=+25°C, VDD =+3.3V)

Item	Symbol	Values			Unit	Remark
		Min.	Typ.	Max.		
Logic Supply Voltage	VDDI	3.13	3.3	3.46	V	Ta=25°C
Analog Supply Voltage	VDD	3.13	3.3	3.46	V	
Input High Voltage	V _{IH}	0.7VDDI	-	VDDI	V	
Input Low Voltage	V _{IL}	GND	-	0.3VDDI	V	
Output High Voltage	V _{OH}	GND	-	-	V	
Output Low Voltage	V _{OL}	VDDI-0.4	-	VDDI	V	
Frame Frequency	f _{FRAME}	-	70	-	HZ	

Note: To prevent IC latch up or DC operation in LCD panel, the power on/off sequence should follow the driver IC specification.

The copyright belongs to InnoLux. Any unauthorized use is prohibited

版權屬於群創所有。禁止任何未經授權的使用

The copyright belongs to INNOLUX. Any unauthorized use is prohibited.

4.2.2 Current Consumption

Item	Symbol	Values		Unit	Remark
		Typ.	Max.		
(RGB 18-bit parallel Interface)					
Standby Mode	VDDI	50	200	uA	Note1, Note2
	VDD	5	10	uA	
Still Mode	VDDI	0.54	1	mA	Note1
	VDD	7.5	10	mA	

Note1: Test Condition

Typ: VDD=3.3V

VDDI=3.3V

Display Pattern: 8 Color Bar

Frame Rate=70Hz at Line Inversion

Operating Temperature: 25°C

Max: VDD=3.46V

VDDI=3.46V

Display: Pattern: All Pixel Black

Frame Rate=70Hz at Line Inversion

Operating Temperature: 25°C

Typ. current check pattern:

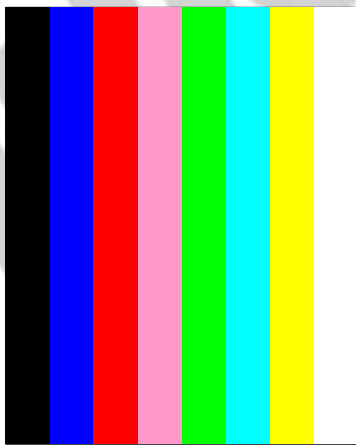

8-Color Bar

Max. current check pattern:

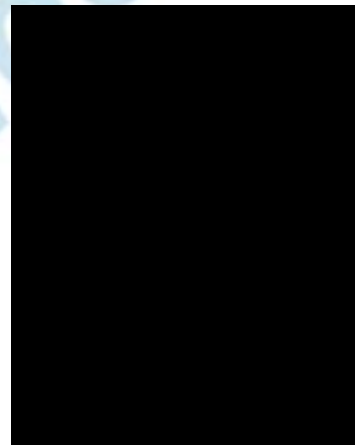

Black

Note2: In the standby mode, all the internal display operations are suspended including the internal R-C oscillator.

The copyright belongs to InnoLux. Any unauthorized use is prohibited

版權屬於群創所有。禁止任何未經授權的使用

The copyright belongs to INNOLUX. Any unauthorized use is prohibited.

4.3. Backlight Unit (LED Type)

The backlight system is an edge lighting type with 3 white LEDs.

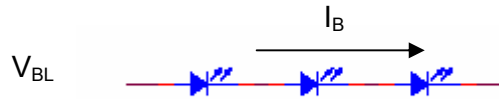

Item	Symbol	Values			Unit	Remark
		Min.	Typ.	Max.		
Current	I_B	-	20	-	mA	Note 1
Power Consumption	P_{BL}	-	217.5	-	mW	Note 1,2

Note1: 3 LEDs are connected in serial; LED current consumption is 20 mA

Note2: Where $I_B = 20\text{mA}$, $P_{BL} = I_B \times V_{BL}$

4.4. Instruction List

Register	Description	Value	Remark
R01	VCOM Amplitude	0x0F	-
R02	VCOM High Voltage	0x2C	-
R03	VREG1OUT Voltage	0x0B	-
R05	Power Setting	0x25	-
R06	Entry Control	0x6C	-
R07	Power Control	0xEF	-
R08	Vertical Back Porch	0x11	-
R09	Horizontal Back Porch	0x80	-
R0A	Polarity	0x49	-
R0B	Display	0x01	-
R0C	DC/DC	0x24	-
R0D	Driving	0x0A	-
R0E	CONTRAST	0x08	-
R0F	BRIGHT	0x82	-
R10	Gamma1	0x6B	-
R11	Gamma2	0x6F	-
R12	Gamma3	0x69	-
R13	Gamma4	0x68	-
R14	Gamma5	0x6A	-
R15	Gamma6	0x5C	-
R16	Gamma7	0x6F	-
R17	Gamma8	0x5B	-
R30	Power	0x09	-
R42	OTP Program	0x40	-

R42 The copyright belongs to Innolux. Any unauthorized use is prohibited

版權屬於群創所有。禁止任何未經授權的使用

The copyright belongs to INNOLUX. Any unauthorized use is prohibited.

4.5. Instruction Setting Flow

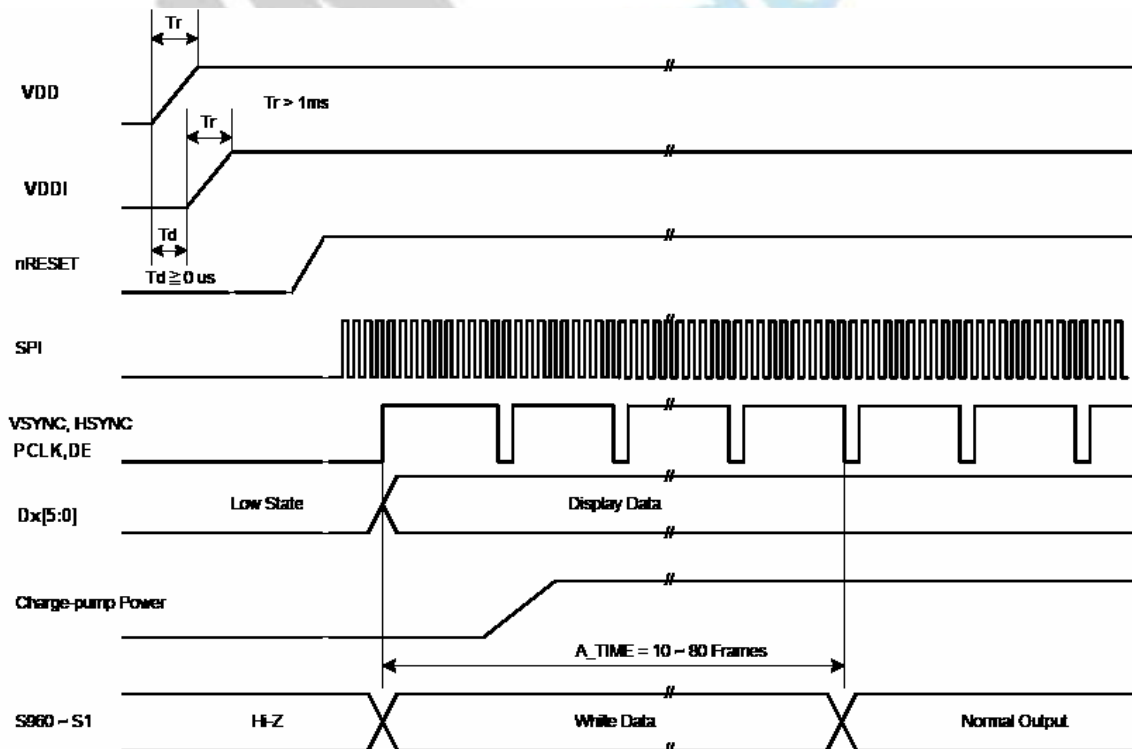
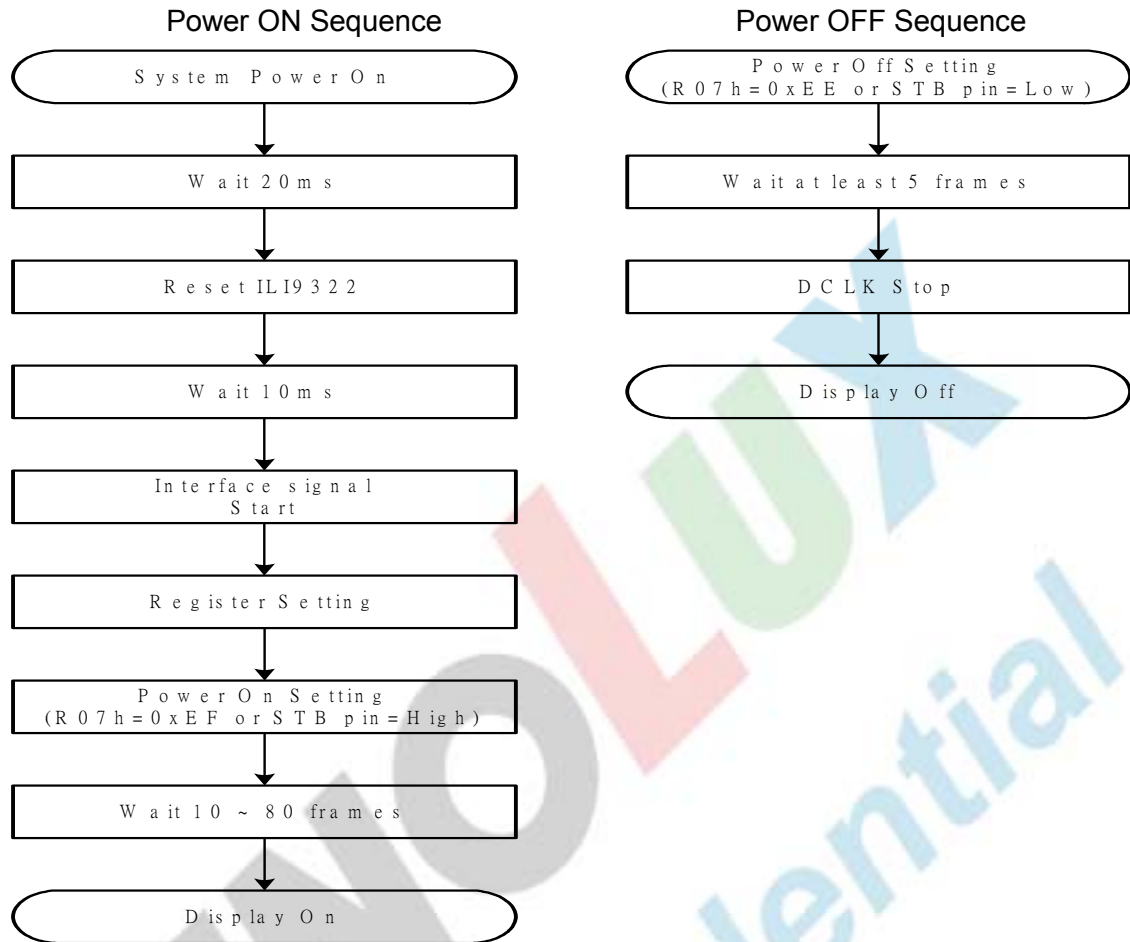

Power on sequence

The copyright belongs to InnoLux. Any unauthorized use is prohibited

版權屬於群創所有。禁止任何未經授權的使用

The copyright belongs to INNOLUX. Any unauthorized use is prohibited.

Standby Mode Sequence

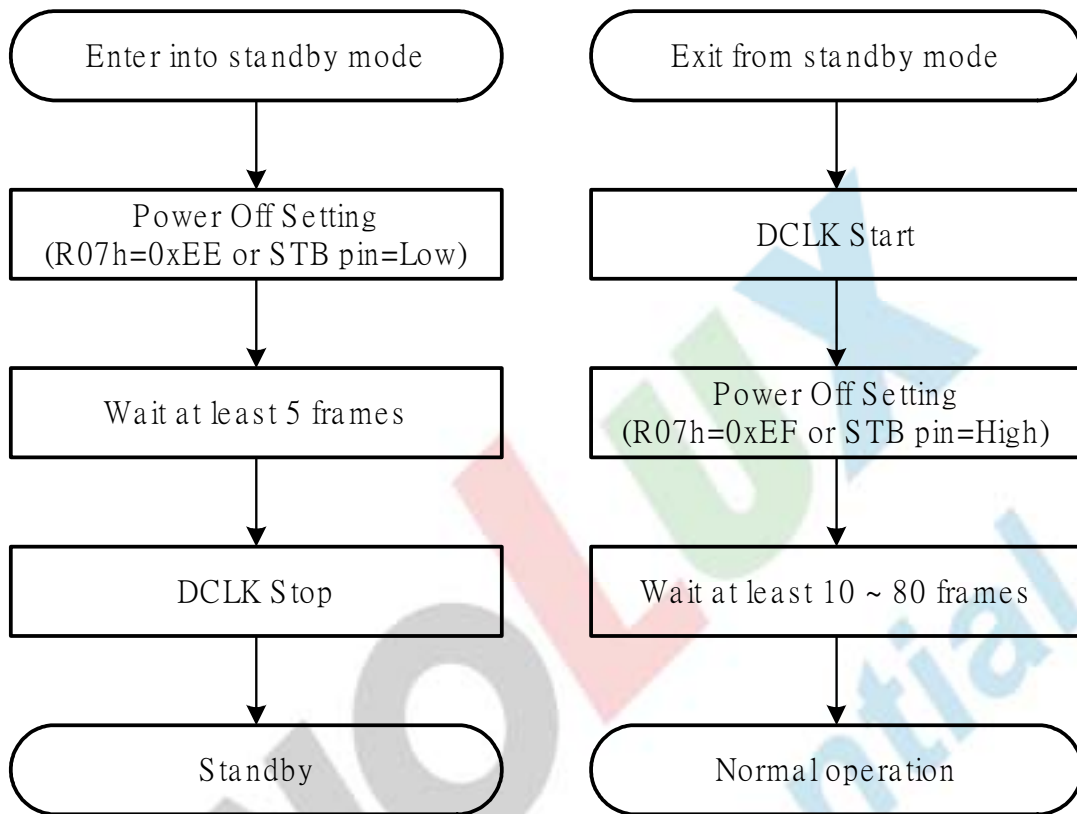

4.6. Timing Characteristics

4.6.1 SPI Interface Timing

Serial Peripheral Interface (SPI) Timing Characteristics

Item		Symbol	Min.	Typ.	Max.	Unit
SPI_/CS to CLK	Setup Time	t _{CS}	50	-	-	ns
	Hold Time	t _{CE}	50	-	-	
SPI_CLK Period		t _{SCK}	50	-	-	ns
SPI_CLK High Period		t _{SKH}	25	-	-	ns
SPI_CLK Low Period		t _{SKL}	25	-	-	ns
SPI_SDI Data Setup Time		t _{SU}	15	-	-	ns
SPI_SDI Data Hold Time		t _{HD}	15	-	-	ns
SPI_/CS High Pulse Period		t _{CH}	50	-	-	ns

The copyright belongs to InnoLux. Any unauthorized use is prohibited

版權屬於群創所有。禁止任何未經授權的使用

The copyright belongs to INNOLUX. Any unauthorized use is prohibited.

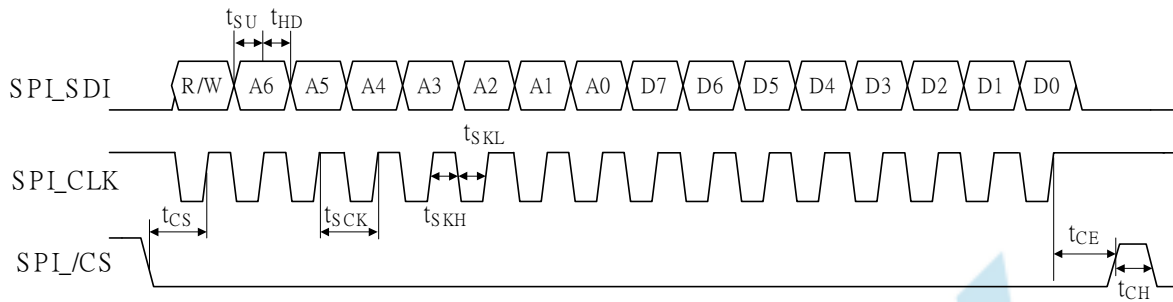

R/W = 1 , Read Mode
R/W = 0 , Write Mode

4.6.2 Parallel RGB Interface Timing

RGB Digital Timing Characteristics

Parameter		Symbol	Min.	Typ.	Max.	Unit.	Note
DCLK Frequency		$1/t_{DCLK}$	-	6.4	10	MHz	-
HSYNC	Period	t_H	360	408	-	t_{DCLK}	-
	Display Period	t_{HD}	320	320	320	t_{DCLK}	-
	Back Porch	t_{HB}	38	38	-	t_{DCLK}	-
	Front Porch	t_{HF}	12	50	-	t_{DCLK}	-
	Pulse Width	t_{HP}	1	1	-	t_{DCLK}	-
VSYNC	Period	t_V	244	262	-	t_H	-
	Display Period	t_{VD}	240	240	240	t_H	-
	Back Porch	t_{VB}	2	18	-	t_H	-
	Front Porch	t_{VF}	2	4	-	t_H	-
	Pulse Width	t_{VP}	1	1	-	t_H	-
Data setup time		t_{SU}	12	-	-	ns	-
Data hold time		t_{HOLD}	12	-	-	ns	-

The copyright belongs to InnoLux. Any unauthorized use is prohibited

版權屬於群創所有，禁止任何未經授權的使用

The copyright belongs to INNOLUX. Any unauthorized use is prohibited.

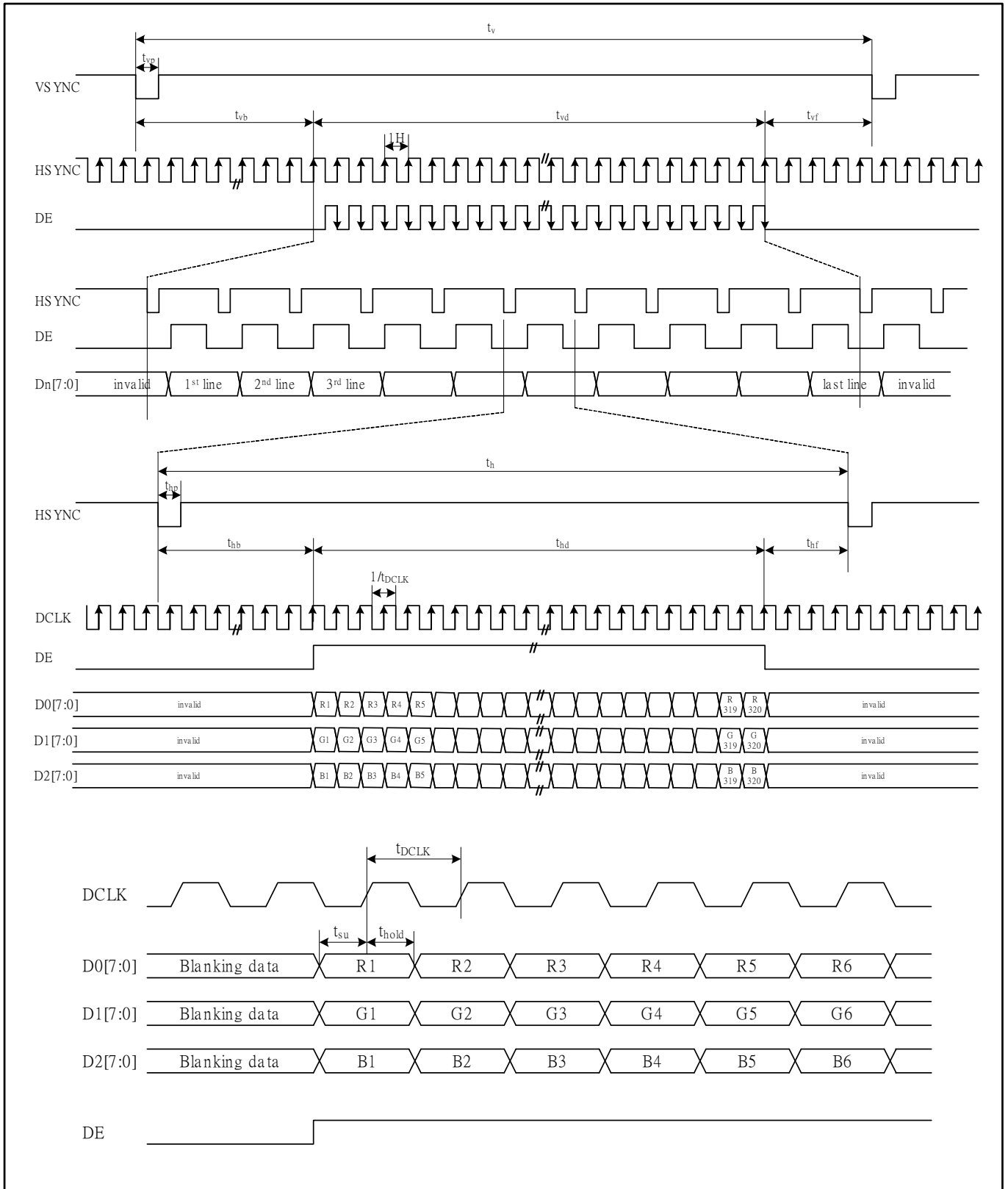

The copyright belongs to InnoLux. Any unauthorized use is prohibited

版權屬於群創所有。禁止任何未經授權的使用

The copyright belongs to INNOLUX. Any unauthorized use is prohibited.

5. Optical Specifications

(Ta=+25°C, VDD=+3.3V, I_B=20mA)

Item	Symbol	Condition	Values			Unit	Remark	
			Min.	Typ.	Max.			
Response time	Ton +Toff	Normal $\theta=\phi=0^\circ$	-	30	50	ms	Note 2	
Contrast ratio	CR	At optimized viewing	150	250	-	-	Note 3	
Luminance	L	Normal $\theta=\phi=0^\circ$	200	250	-	cd/m ²	Note 4,6	
Color chromaticity (CIE1931)	White	W _x	0.26	0.31	0.36	-	Note 5,6	
		W _y	0.28	0.33	0.38			
Viewing angle	Left	ϕ_L	CR \geq 10	40	45	-	Degree	Note 10
	Right	ϕ_R		40	45	-		
	Top	ϕ_T		50	55	-		
	Bottom	ϕ_B		10	15	-		
Color Gamut		CIE1931	40	50	-	%	-	
Luminance uniformity	U _L	Normal $\theta=\phi=0^\circ$	70	75	-	%	Note 7	
Flicker		-	Not visible			-	Note 8	
Cross talk		-	Not visible			-	Note 9	

The copyright belongs to InnoLux. Any unauthorized use is prohibited

版權屬於群創所有，禁止任何未經授權的使用

The copyright belongs to INNOLUX. Any unauthorized use is prohibited.

Note 1: Definition of optical measurement system.

The optical characteristics should be measured in dark room and with ambient temperature $T_a=25C$. After 30 minutes operation, the optical properties are measured at center point of the LCD screen. (Equipment: Photo detector TOPCON BM-5A or BM-7 /Field of view: 1° /Height: 500mm.)

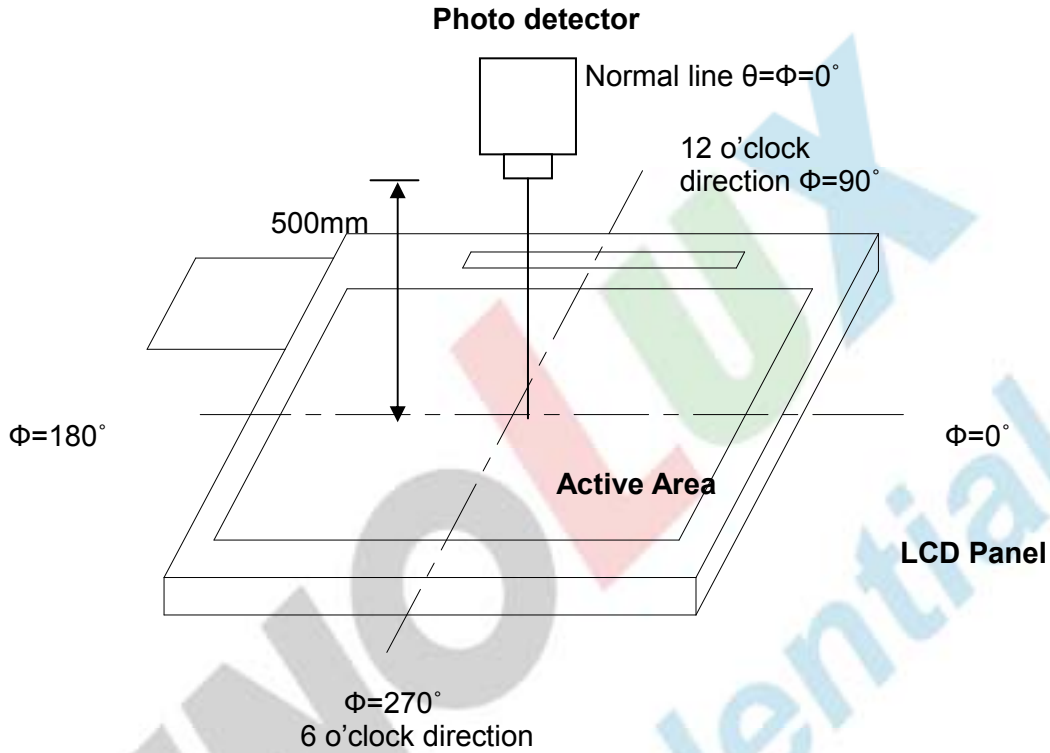

Fig. 1 Optical measurement system setup

Note 2: Definition of response time

The response time is defined as the LCD optical switching time interval between "White" state and "Black" state. Rise time (TON) is the time between photo detector output intensity changed from 90% to 10%. And fall time (TOFF) is the time between photo detector output intensity changed from 10% to 90%.

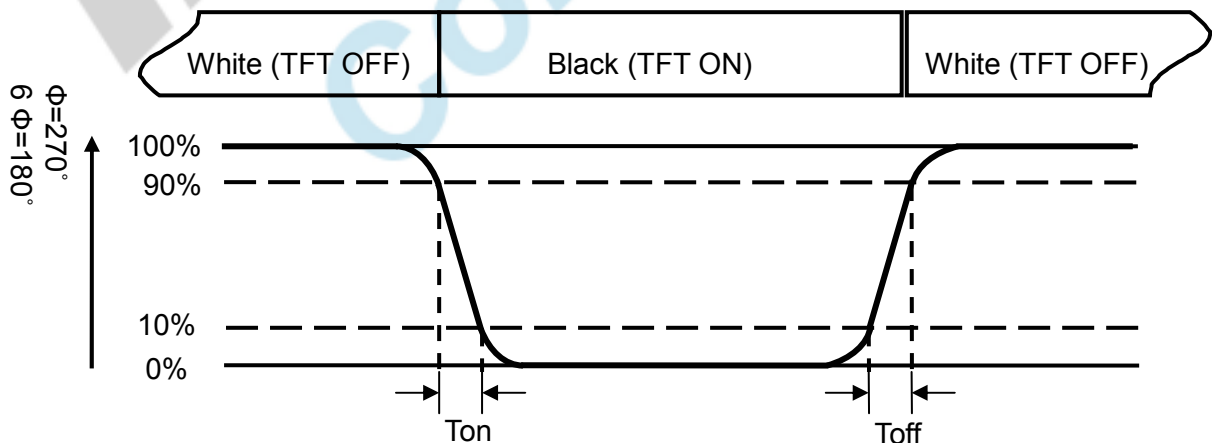

Fig. 2 Definition of response time

The copyright belongs to InnoLux. Any unauthorized use is prohibited

版權屬於群創所有。禁止任何未經授權的使用

The copyright belongs to INNOLUX. Any unauthorized use is prohibited.

Note 3: Definition of contrast ratio

$$\text{Contrast ratio (CR)} = \frac{\text{Luminance measured when LCD on the "White" state}}{\text{Luminance measured when LCD on the "Black" state}}$$

Note 4: Definition of luminance: Luminance of “white” state measured at the center point of LCD.

Note 5: Definition of color chromaticity (CIE1931). Color coordinates measured at the center point of LCD when panel is driven at “White” state respectively.

Note 6: Measured at the center area of the panel when all the input terminals of LCD panel are electrically opened.

Note 7: Definition of uniformity: To test for uniformity, the tested area is divided into 3 rows and 3 columns. The measurement spot is placed at the center of each box.

$$\text{Luminance Uniformity (U}_L\text{)} = \frac{L_{\min}}{L_{\max}}$$

W-----Active area width L----- Active area length

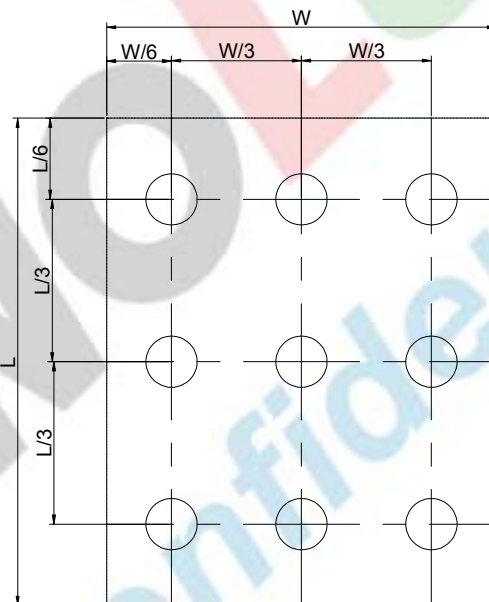

Fig. 3 Definition of uniformity

L_{\max} : The measured maximum luminance of all measurement position.

L_{\min} : The measured minimum luminance of all measurement position.

The copyright belongs to InnoLux. Any unauthorized use is prohibited

版權屬於群創所有。禁止任何未經授權的使用

The copyright belongs to INNOLUX. Any unauthorized use is prohibited.

Note 8: Definition of flicker: There should be no visible flicker in the display when the following figures are loaded.

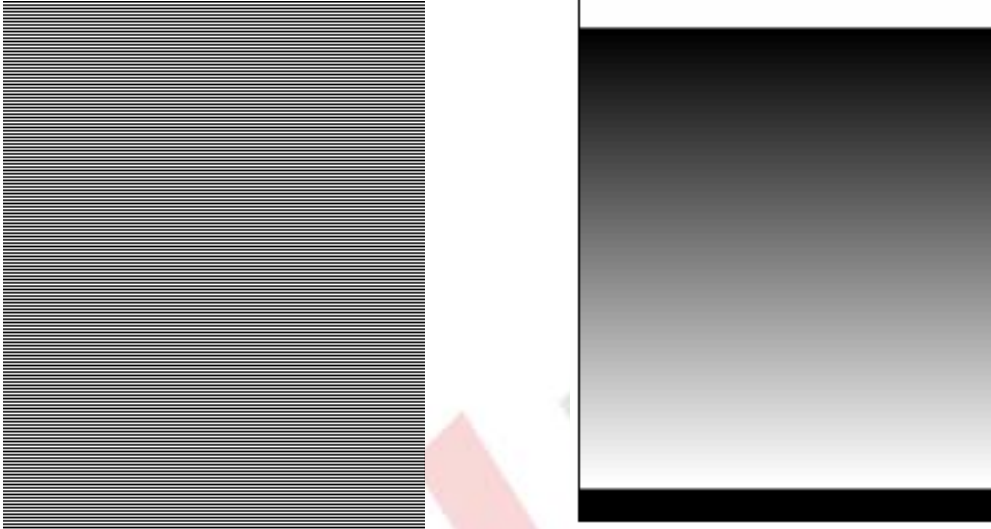

Fig. 4 Flicker check pattern

Note 9: Definition of crosstalk: There should be no visible crosstalk in normal direction of the display when the following figures are loaded

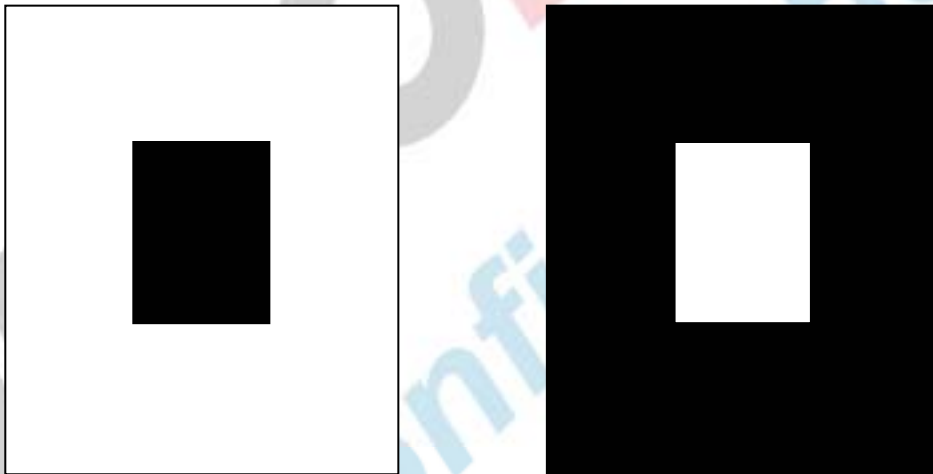

Fig. 5 Crosstalk check pattern

The copyright belongs to InnoLux. Any unauthorized use is prohibited

版權屬於群創所有，禁止任何未經授權的使用

The copyright belongs to INNOLUX. Any unauthorized use is prohibited.

Note 10: Definition of viewing angle range

Fig. 6 Definition of viewing angle

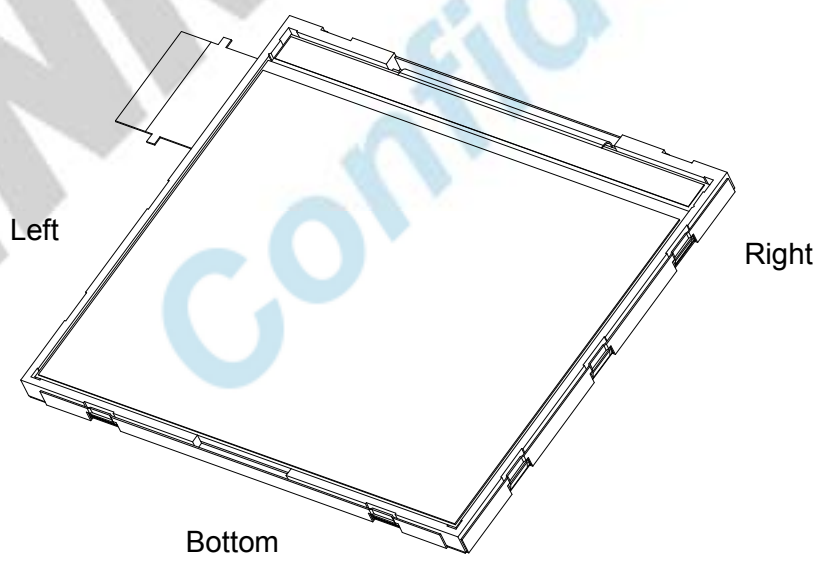
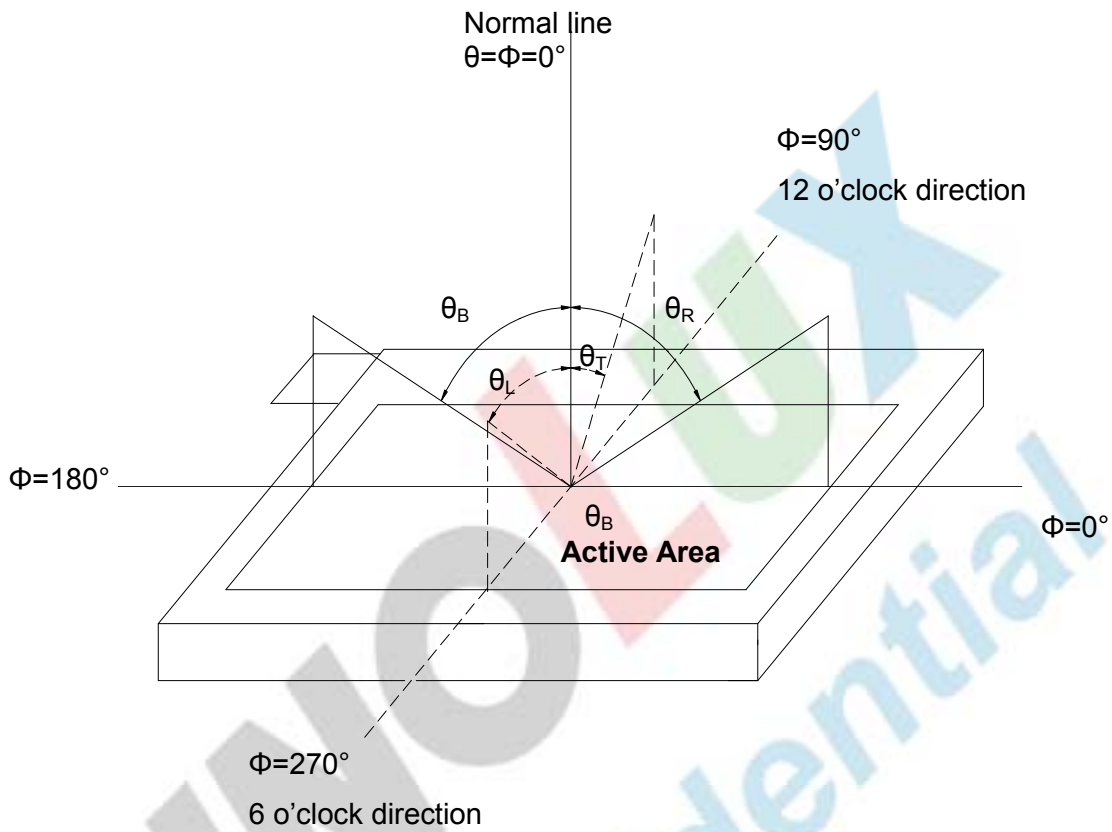

Fig. 7 Definition of viewing direction for display

The copyright belongs to InnoLux. Any unauthorized use is prohibited

版權屬於群創所有。禁止任何未經授權的使用

The copyright belongs to INNOLUX. Any unauthorized use is prohibited.

6. Reliability Test Items

(Note1)

Test Items	Test Conditions	Remark
High Temperature Storage	+70°C±3°C for 240 hours	Note2
Low Temperature Storage	-20°C±3°C for 240 hours	Note2
High Temperature Operation	+60°C±3°C for 240 hours	Note2
Low Temperature Operation	-10°C±3°C for 240 hours	Note2
Operate at High Temperature and Humidity	+60°C±3°C, 90%±3%RH max. for 240 hours	Note2
Thermal Shock	-20°C/0.5h ~ +70°C/0.5h for a total 100 cycles, Start with cold temp and end with high temp	Note2
Vibration Test	Frequency range:10~55Hz Stoke:1.5mm Sweep:10Hz~55Hz~10Hz 2 hours for each direction of X. Y. Z. (6 hours for total)	JIS C7021 A-10 Condition A
Mechanical Shock	100G 6ms,±X, ±Y, ±Z 3 times for each direction	JIS C7021 A-7 Condition C
Package Vibration Test	Random Vibration : 0.015G ² /Hz from 5-200Hz, -6dB/Octave from 200-500Hz 2 hours for each direction of X. Y. Z. (6 hours for total)	IEC 68-34
Package Drop Test	Height:72cm(Weight ≤ 10kg); 60cm(Weight ≥ 10kg) 1 corner, 3 edges, 6 surfaces	JIS Z0202
Electro Static Discharge	± 2KV, Human Body Mode, 100pF/1500Ω, LCM Power ON	

Note1: In the standard condition, there shall be no practical problem that may affect the display function.
After the reliability test, the product only guarantees operation, but doesn't guarantee all the cosmetic specification.

Note2: Before cosmetic and function tests , the product must have enough recovery time,at least 2 hours at room temperature.

The copyright belongs to InnoLux. Any unauthorized use is prohibited

版權屬於群創所有。禁止任何未經授權的使用

The copyright belongs to INNOLUX. Any unauthorized use is prohibited.

7. Handling Precautions

7.1 Safety

7.1.1 The liquid crystal in the LCD is poisonous. DO NOT put it in your mouth. If the liquid crystal touches your skin or clothes, wash it off immediately using soap and water.

7.2. Handling

7.2.1. The LCD panel is plate glass. DO NOT subject the panel to mechanical shock or to excessive force on its surface.

7.2.2. The polarizer attached to the display is very easy to damage, handle it with careful attention.

7.2.3. To avoid contamination on the display surface, DO NOT touch the display surface with bare hands.

7.2.4. Provide a space so that the LCD panel does not come into contact with other components.

7.2.5. To protect the LCD panel from external pressure, put covering glass (acrylic board or similar board) keeping appropriate gap between them.

7.2.6. Transparent electrodes may be disconnected if you use the LCD panel under environmental conditions where dew condensation occurs.

7.2.7. Property of semiconductor devices may be affected when they are exposed to light, possibly resulting in malfunctioning of the ICs.

7.2.8. To prevent such malfunctioning of the ICs, your design and mounting layout done are so that the IC is not exposed to light in actual use.

7.3. Static Electricity

7.3.1. Ground soldering iron tips, tools and testers when you operate.

7.3.2. Ground your body when handling the products.

7.3.3. DO NOT apply voltage to the input terminal without applying power supply.

7.3.4. DO NOT apply voltage which exceeds the absolute maximum rating.

7.3.5. Store the products in an anti-electrostatic container.

7.4. Storage

7.4.1. Store the products in a dark place at $+25^{\circ}\text{C} \pm 10^{\circ}\text{C}$, low humidity (65%RH or less).

7.4.2. DO NOT store the products in an atmosphere containing organic solvents or corrosive gases.

7.5. Cleaning

7.5.1 DO NOT wipe the polarizer with dry cloth, as it might cause scratch.

7.5.2 Wipe the polarizer with a soft cloth soaked with petroleum IPA, other chemical might damage.

The copyright belongs to InnoLux. Any unauthorized use is prohibited

版權屬於群創所有。禁止任何未經授權的使用

The copyright belongs to INNOLUX. Any unauthorized use is prohibited.

8 Mechanical Drawing

REV	EC NUMBER	DESCRIPTION	DATE
▽	XXXXXX	XXXXXXXX	XXXX/XX/XX

10	9	8	7	6	5	4	3	2
----	---	---	---	---	---	---	---	---

LEVEL	GENERAL LINEAR TOLERANCE	3rd ANGLE	SCALE	UNIT	SPEC DIMENSION	D/P/N	PROJ NUMBER	PROJ DESCRIPTION	DATE	DESIGNER	CHECKER	APPROVED
0 - 4	0.5	☉	1:1	mm	○	Jack Huang	AC0250001031	LCM CT025TN01	2007/12/25			
4 - 14	0.2					Zhfeng Fu			2007/12/25			
14 - 25	0.1					Xinghao Huang			2007/12/25			
25 - 50	0.1											
50 - 100	0.1											
100 - 4000	0.1											
GENERAL TOLERANCE	0.1											
LEVEL	RANGE	P	P	P	P	P	P	P	P	P	P	P

Notes:

- DISPLAY TYPE: TFT-LCD, TRANSMISSIVE;
- BRIGHTNESS: 250mTs;
- LED: 3.LEDs 20mA/LED;
- LCD DRIVER: ILI 9322;
- INTERFACE: RGB 18 bit;
- CONNECTOR TYPE: SD-54393-3918;
- VIEWING DIRECTION: 12 o'clock;
- Barcode content including:

INL Model Name: INL P/N

GP: CT025TN01, A02E0010 3I

MITAC P/N: 4160060737

INL S/N: 5-N35355556573859301512 Y7AW

CODE	DESCRIPTION
SI-SIC	INNOVUX PROCESS CONTROL CODE
WW	WEEK CODE
YY	YEAR CODE

P in Assignment	1	2	3	4	5	6	7	8	9	10
1	LED-A									
2	LED-C									
3	VDDI									
4	VDD									
5	GND									
6	GPD									
7	VCOMH									
8	DDVDH									
9	NC									
10	SPI/CS									
11	SPI/SDI									
12	SPI/SDO									
13	SPI/CLK									
14	NC									
15	/RST									
16	B0									
17	B1									
18	B2									
19	B3									
20	B4									
21	B5									
22	G0									
23	G1									
24	G2									
25	G3									
26	G4									
27	G5									
28	R0									
29	R1									
30	R2									
31	R3									
32	R4									
33	R5									
34	GND									
35	PCJK									
36	GND									
37	VSXNC									
38	HSXNC									
39	DE									

The copyright belongs to InnoLux. Any unauthorized use is prohibited

版權屬於群創所有，禁止任何未經授權的使用

The copyright belongs to INNOLUX. Any unauthorized use is prohibited.

9 Package Drawing

9.1.Packaging Material Table

Per Carton

No	Item	Model (Material)	Dimensions(mm)	Unit Weight(Kg)	Quantity	Remark
1	LCM module	CT025TN01	56.4×49.12×2.7	0.015	480	
2	Tray	PE	345×245×18	0.090	42	Anti-static
3	Dust-Proof Bag	PE	410×365×0.8	0.048	2	
4	Partition	Corrugated Paper	340×254×230	0.220	2	
5	Carton	Corrugated Paper	530×355×255	1.100	1	
6	Total weight	12.800kg±5%				

9.2.Packaging Quantity

(1) LCM quantity in per Tray:	12 pcs
(2) Total LCM quantity in per Carton:	2 set x 12pcs per tray x20 pcs tray = 480pcs

The copyright belongs to InnoLux. Any unauthorized use is prohibited

版權屬於群創所有，禁止任何未經授權的使用

The copyright belongs to INNOLUX. Any unauthorized use is prohibited.

9.3.Package Drawing

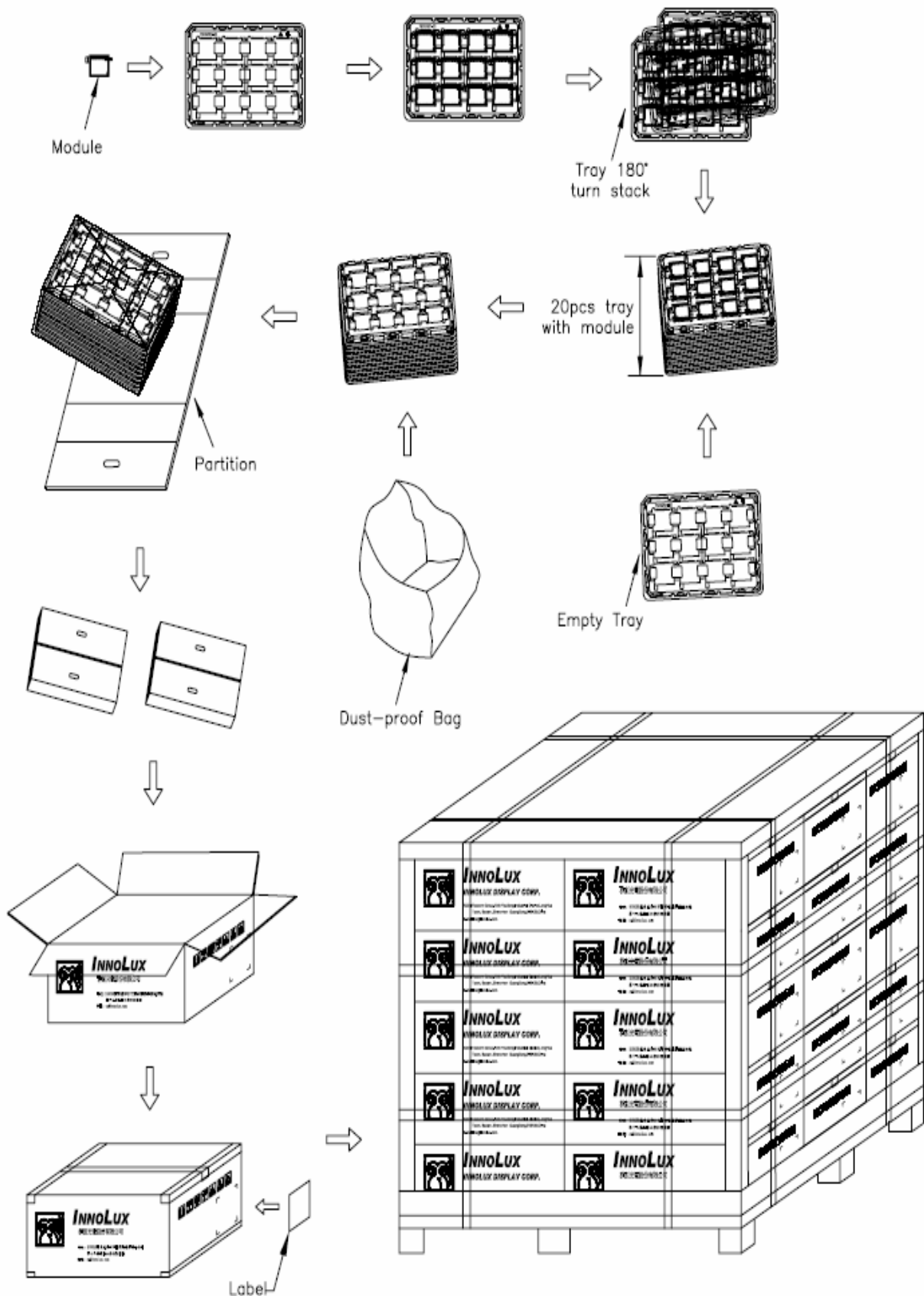

The copyright belongs to InnoLux. Any unauthorized use is prohibited

版權屬於群創所有。禁止任何未經授權的使用

The copyright belongs to INNOLUX. Any unauthorized use is prohibited.